

# Atlantic States Marine Fisheries Commission

## Sciaenids Management Board

*October 22, 2024*

*8:30 – 11:30 a.m.*

### Draft Agenda

The times listed are approximate; the order in which these items will be taken is subject to change; other items may be added as necessary.

1. Welcome/Call to Order (*D. Haymans*) 8:30 a.m.
2. Board Consent 8:30 a.m.
  - Approval of Agenda
3. Public Comment 8:35 a.m.
4. Consider 2024 Red Drum Benchmark Stock Assessment and Peer Review Report **Action** 8:45 a.m.
  - Presentation of Stock Assessment (*J. Ballenger*)
  - Presentation of Peer Review Panel Report (*G. Fay*)
  - Consider Acceptance of Benchmark Stock Assessment and Peer Review Report for Management Use
  - Consider Management Response, If Necessary (*D. Haymans*)
5. Discuss Risk and Uncertainty Tool Inputs for Red Drum (*K. Drew*) 10:20 a.m.
6. Consider Annual Update to Black Drum Indicators (*H. Rickabaugh*) 11:00 a.m.  
**Possible Action**
7. Consider Black Drum and Spotted Seatrout Fishery Management Plan Reviews and State Compliance for the 2023 Fishing Year (*T. Bauer*) **Action** 11:15 a.m.
8. Other Business/Adjourn 11:30 a.m.

The meeting will be held at The Westin Annapolis (100 Westgate Circle, Annapolis, MD; 888.627.8994) and via webinar; click [here](#) for details

# MEETING OVERVIEW

## Sciaenids Management Board

October 22, 2024

8:30 a.m. – 11:30 a.m.

Chair: Doug Haymans (GA) Assumed Chairmanship: 02/24	Technical Committee Chairs: Black Drum: Harry Rickabaugh (MD) Atlantic Croaker: Vacant Red Drum: Ethan Simpson (VA) Spot: Harry Rickabaugh (MD)	Law Enforcement Committee Representative: Col. Matthew Rogers (VA)
Vice Chair: Vacant	Advisory Panel Chair: Craig Freeman (VA)	Previous Board Meeting: October 3, 2024
Voting Members: NJ, DE, MD, PRFC, VA, NC, SC, GA, FL, NMFS (10 votes)		

### 2. Board Consent

- Approval of Agenda

**3. Public Comment** – At the beginning of the meeting public comment will be taken on items not on the agenda. Individuals that wish to speak at this time must sign-in at the beginning of the meeting. For agenda items that have already gone out for public hearing and/or have had a public comment period that has closed, the Board Chair may determine that additional public comment will not provide additional information. In this circumstance the Chair will not allow additional public comment on an issue. For agenda items that the public has not had a chance to provide input, the Board Chair may allow limited opportunity for comment. The Board Chair has the discretion to limit the number of speakers and/or the length of each comment.

### 4. Consider 2024 Red Drum Benchmark Stock Assessment and Peer Review Report (8:45-10:20 a.m.)

#### Background

- The 2024 red drum benchmark stock assessment evaluated the status of two red drum stocks along the U.S. Atlantic Coast, the northern stock which extends from New Jersey to the North Carolina/South Carolina border and the southern stock which extends from the North Carolina/South Carolina border through the east coast of Florida (**Briefing Materials**).
- The 2024 red drum benchmark stock assessment was completed and peer-reviewed by a panel of independent experts in August 2024. The Peer Review Report provides the panel's evaluation of the assessment findings (**Briefing Materials**).
- After reviewing the stock assessment, the Board may consider management responses based on the assessment results.

**Presentations**

- Presentation of Stock Assessment Report by J. Ballenger
- Presentation of Peer Review Report by G. Fay

**Board actions for consideration at this meeting**

- Consider acceptance of benchmark stock assessment and peer review report for management use.
- Consider management response, if necessary.

**5. Discuss Risk and Uncertainty Tool Inputs for Red Drum (10:20-11:00 a.m.)****Background**

- The Risk and Uncertainty Decision Tool uses information on stock status, model uncertainty, management uncertainty, ecosystem considerations, and socioeconomic factors to recommend the probability of success that management actions should strive to achieve.
- The recommended probability will be determined by the results of the Red Drum Benchmark Stock Assessment, the technical and socioeconomic inputs, and the Board's final decisions on weightings, all of which will be discussed at this meeting (**Supplemental Materials**).

**Presentations**

- Presentation on the Risk and Uncertainty Tool by K. Drew.

**6. Consider Annual Update to Black Drum Indicators (11:00-11:15 a.m.)****Background**

- Empirical stock indicators were developed as part of the 2023 black drum benchmark stock assessment and were recommended to be monitored annually between stock assessments to detect any concerning trends in the black drum stock.
- For this year's update, the indicators were updated with one additional year of data, 2023.
- The Black Drum Technical Committee (TC) met on October 2 to review the results of the data update to the indicators and make recommendations (**Supplemental Materials**). Overall, the TC did not believe the updated indicator values deviated far enough outside of the historical range to cause concern, though increases in recreational and commercial landings were noted in the South Atlantic. The TC recommends scheduling the next data update to the indicators in 2026, and moving the next scheduled black drum stock assessment from 2027 to 2028.

**Presentations**

- Presentation of Black Drum Indicators Data Update by H. Rickabaugh

**7. Consider Black Drum and Spotted Seatrout Fishery Management Plan Reviews and State Compliance for the 2023 Fishing Year (11:15-11:30 a.m.)****Background**

- Black drum state compliance reports are due on August 1. The Black Drum Plan Review Team (PRT) has reviewed state compliance reports and compiled the annual FMP review. There were no requests by states for *de minimis* status (**Briefing Materials**).

- Spotted Seatrout state compliance reports are due on September 1. The Spotted Seatrout Plan Review Team (PRT) has reviewed state compliance reports and compiled the annual FMP Review. New Jersey and Delaware have requested continued *de minimis* status (**Briefing Materials**).

**Presentations**

- 2023 FMP Reviews for Black Drum and Spotted Seatrout by T. Bauer

**Board actions for consideration at this meeting**

- Consider approval of the 2023 FMP Review and state compliance reports for Black Drum.
- Consider approval of the 2023 FMP Review, state compliance reports, and New Jersey and Delaware's *de minimis* requests for Spotted Seatrout.

**8. Other Business/Adjourn**

## Sciaenids Management Board

**Activity level: High**

**Committee Overlap Score:** Moderate (American Eel TC, Cobia TC, Horseshoe Crab TC, Weakfish TC)

### Committee Task List

- Atlantic Croaker and Spot SAS – Conduct Atlantic Croaker and Spot Benchmark Assessments
- Black Drum TC – Update annual indicators
- Atlantic Croaker TC – Gather data and assist with Atlantic Croaker Benchmark Assessment; Conduct Traffic Light Analysis
- Spot TC – Gather data and assist with Spot Benchmark Assessment; Conduct Traffic Light Analysis
- Atlantic Croaker TC/PRT – July 1: Compliance Reports Due
- Red Drum TC/PRT – July 1: Compliance Reports Due
- Black Drum TC/PRT – August 1: Compliance Reports Due
- Spotted Seatrout PRT – September 1: Compliance Reports Due
- Spot TC/PRT – November 1: Compliance Reports Due

### TC Members:

**Atlantic Croaker:** Kristen Anstead (ASMFC), Tracey Bauer (ASMFC), Stacy VanMorter (NJ), Devon Scott (DE), Harry Rickabaugh (MD), Ingrid Braun (PRFC), Willow Patten (NC), Margaret Finch (SC), Dawn Franco (GA), Halie OFarrell (FL)

**Black Drum:** Harry Rickabaugh (MD, Chair), Jeff Kipp (ASMFC), Tracey Bauer (ASMFC), Jennifer Pyle (NJ), Jordan Zimmerman (DE), Ethan Simpson (VA), Chris Stewart (NC), Chris McDonough (SC), Ryan Harrell (GA), Rebecca Scott (FL)

**Red Drum:** Ethan Simpson (VA, Chair), Jeff Kipp (ASMFC), Tracey Bauer (ASMFC), Alissa Wilson (NJ), Matthew Jargowsky (MD), Cara Kowalchuk (NC, Vice-Chair), Joey Ballenger (SC), Chris Kalinowsky (GA), Sarah Burnsed (FL)

**Spot:** Harry Rickabaugh (MD, Chair), Jeff Kipp (ASMFC), Tracey Bauer (ASMFC), Stacy VanMorter (NJ), Devon Scott (DE), Ingrid Braun (PRFC), Willow Patten (NC), Michelle Willis (SC), Britney Hall (GA), Halie OFarrell (FL)

**Plan Review Team Members:**

**Atlantic Croaker:** Harry Rickabaugh (MD), Ingrid Braun (PRFC), Ethan Simpson (VA), Willow Patten (NC), Chris McDonough (SC), Tracey Bauer (ASMFC)

**Black Drum:** Jordan Zimmerman (DE), Chris Stewart (NC), Chris McDonough (SC), Tracey Bauer (ASMFC)

**Red Drum:** Matthew Jargowsky (MD), Ethan Simpson (VA), Cara Kowalchuk (NC), Joey Ballenger (SC), Matt Kenworthy (FL), Tracey Bauer (ASMFC)

**Spot:** Harry Rickabaugh (MD), Ethan Simpson (VA), Chris McDonough (SC), Dawn Franco (GA), Tracey Bauer (ASMFC)

**Spotted Seatrout:** Tracey Bauer (ASMFC), Samantha MacQuesten (NJ), Lucas Pensinger (NC), Brad Floyd (SC), Chris Kalinowsky (GA)

**SAS Members:**

**Red Drum:** Joey Ballenger (SC, Chair), Jeff Kipp (ASMFC), Tracey Bauer (ASMFC), Angela Giuliano (MD), CJ Schlick (SC), Jared Flowers (GA), Chris Swanson (FL), Ethan Simpson (VA)

**Atlantic Croaker and Spot:** Kristen Anstead (ASMFC), Jeff Kipp (ASMFC), Tracey Bauer (ASMFC), Harry Rickabaugh (MD), Brooke Lowman (VA), Trey Mace (MD), Margaret Finch (SC), CJ Schlick (SC)



# SEDAR

## Southeast Data, Assessment, and Review

---

### SEDAR 93

### Atlantic Red Drum

### Review Workshop Report

**Please note that this peer review report has not yet been reviewed by ASMFC's Red Drum Stock Assessment Subcommittee (SAS) or Technical Committee (TC). The SAS and TC will review this report prior to the meeting to determine if any response is necessary.**

**August 2024**

SEDAR  
4055 Faber Place Drive, Suite 201  
North Charleston, SC 29405

## 1. INTRODUCTION

### 1.1 WORKSHOP TIME AND PLACE

The SEDAR 93 Review Workshop was held in Charleston, SC August 13-16, 2024.

### 1.2 TERMS OF REFERENCE

1. Evaluate responses to Simulation Assessment Peer Review Panel recommendations.
2. Evaluate the thoroughness of data collection and the presentation and treatment of fishery-dependent and fishery-independent data in the assessment, including the following but not limited to:
  - a. Presentation of data source variance (e.g., standard errors).
  - b. Justification for inclusion or elimination of available data sources.
  - c. Consideration of data strengths and weaknesses (e.g., temporal and spatial scale, gear selectivities, ageing accuracy, sample size).
  - d. Calculation and/or standardization of abundance indices.
3. Evaluate the methods and models used to estimate population parameters (e.g., F, abundance) and reference points, including but not limited to:
  - a. If modeling approaches differ from those recommended during the Simulation Assessment, were these differences warranted and appropriate?
  - b. Evaluate the choice and justification of the preferred model(s). Was the most appropriate model (or model averaging approach) chosen given available data and life history of red drum?
  - c. Evaluate model parameterization and specification (e.g., choice of CVs, effective sample sizes, likelihood weighting schemes, calculation/specification of M, stock-recruitment relationship, choice of time-varying parameters, plus group treatment).
4. Evaluate the diagnostic analyses performed, including but not limited to:
  - a. Sensitivity analyses to determine model stability and potential consequences of major model assumptions.
  - b. Retrospective analysis.
5. Evaluate the methods used to characterize uncertainty in estimated parameters. Ensure the implications of uncertainty in technical conclusions are clearly stated.
6. If a minority report has been filed, review minority opinion and associated analyses. If possible, make recommendation on current or future use of alternative assessment approach presented in minority report.



7. Recommend best estimates of stock biomass, abundance, and exploitation from the assessment for use in management, if possible, or specify alternative estimation methods.
8. Evaluate the choice of reference points and the methods used to estimate them. Recommend stock status determination from the assessment, or, if appropriate, specify alternative methods/measures.
9. Review the research, data collection, and assessment methodology recommendations provided by the TC and make any additional recommendations warranted. Clearly prioritize the activities needed to inform and maintain the current assessment, and provide recommendations to improve the reliability of future assessments.
10. Review the recommended timeframe for future assessments provided by the TC and recommend any necessary changes.
11. Prepare a peer review panel terms of reference and advisory report summarizing the panel’s evaluation of the stock assessment and addressing each peer review term of reference. Develop a list of tasks to be completed following the workshop. Complete and submit the report within 4 weeks of workshop conclusion.

*1.3 LIST OF PARTICIPANTS*

***Review Panel***

Gavin Fay (Chair)	University of Massachusetts-Dartmouth
Kotaro Ono	CIE Reviewer
Geoff Tingley	CIE Reviewer
Katyana Vert-Pre	CIE Reviewer

***Analytic Team***

Joey Ballenger	SCDNR
Tracey Bauer	ASMFC
Jared Flowers	GADNR
Angela Giuliano	MDDNR
Jimmy Kilfoil	SCDNR
Jeff Kipp	ASMFC
CJ Schlick	SCDNR

***Staff***

Julie A Neer	SEDAR
Emily Ott	SEDAR
Rachael Silvas	SAFMC Staff

**Workshop Observers**

Chip Collier

SAFMC Staff

**Workshop Observers via Webinar**

Alan Bianchi

NCDNR

Pat Campfield

ASMFC

Manuel Coffill-Rivera

University of South Alabama

Dawn Franco

GADNR

Ryan Harrell

GADNR

Matthew Jargowsky

MDDNR

Chris Kalinowsky

GADNR

Cara Kowalchyk

NCDNR

Laura Lee

USFWS

Rebecca Scott

FLFWCC

**1.4 LIST OF REVIEW WORKSHOP REFERENCE DOCUMENTS**

Document #	Title	Authors
<b>Reference Documents</b>		
SEDAR93-RD01	Red Drum Simulation Assessment and Peer Review Report	Atlantic States Marine Fisheries Commission
SEDAR93-RD02	Estimating the tag-reporting rate and length-based selectivity of red drum ( <i>Sciaenops ocellatus</i> ) in South Carolina using a long-term tag-recapture study	Lukas Ugland Troha
SEDAR93-RD03	Spatial synchrony and temporal dynamics of juvenile red drum <i>Sciaenops ocellatus</i> populations in South Carolina, USA	Stephen A. Arnott, William A Roumillat, John A. Archambault, Charles A. Wenner, Joy I. Gerhard, Tanya L. Darden, Michael R. Denson

**2. REVIEW PANEL REPORT**

The panel report addresses each of the terms of reference.

**1. Evaluate responses to Simulation Assessment Peer Review Panel recommendations.**

Work presented by the SAS in the stock assessment report and during the review workshop to address the Simulation Assessment Peer Review Panel recommendations included:

- a. Revised grid search for deriving reference points for the Traffic Light Analysis (TLA) to only include data available to a TLA model when applied in practice (i.e. pre-2023), and
- b. Further work to demonstrate the southern Stock Synthesis (SS) estimation model (EM) could produce unbiased estimates when fit to data with no observation error.

The revised grid search was used for the basis of optimized TLA reference points in analyses presented in the assessment report.

The SAS presented work to address the performance of the southern (SS) model, with versions of the EM fit to data generated from one iteration of the operating model (OM) with no observation error, both where EM assumptions for growth and  $M$  were the same as in the original simulations (i.e., mis-specified), and when growth and  $M$  were fixed at the operating model true values. Southern EMs fit to data with no observation error showed less relative error in derived quantities for this iteration than in the original simulations, with the relative error of estimate approaching zero as the degree of mis-specification was decreased (Fig. 124, assessment report). Performance was encouraging, though the Panel noted this was only undertaken for a single iteration. Ideally, it would be good to see if the model produces unbiased estimates over multiple scenarios, to ensure the approach is robust to differences in the OM (e.g., recruitment time series). Overall, the Panel agreed this Term of Reference was met.

- 2. Evaluate the thoroughness of data collection and the presentation and treatment of fishery-dependent and fishery-independent data in the assessment, including the following but not limited to:**
  - a. Presentation of data source variance (e.g., standard errors)**
  - b. Justification for inclusion or elimination of available data sources.**
  - c. Consideration of data strengths and weaknesses (e.g., temporal and spatial scale, gear selectivities, aging accuracy, sample size)**
  - d. Calculation and/or standardization of abundance indices**

The presentation of variance in the data sources provided was generally good, with standard error or confidence intervals provided on plotted and tabulated data, where understanding variance was important. Some of the workshop presentation plots did not include variance but this was clarified as necessary.

Multiple data survey sources contributed to indices that would serve as inputs for the southern and northern SS models, TLA, and Skate analysis. The Review Panel was particularly attentive to the standardization processes for survey indices and the spatio-temporal standardization of survey designs. Generally, when an index was excluded, a valid justification was provided. However, the Panel believes improvements can be made in the data and index inclusion/exclusion process. For example, clear analyses were not presented to demonstrate the time series included in the assessment models were all indexing stock abundance and there were no conflicts between time series. The Panel appreciated, and encouraged an emphasis on holistic thinking, particularly to include data that informs different life stages (e.g., recruitment index, subadult index, adult, age/growth for older fish).

Below are the Panel's detailed views on individual indices.

- The historical longline data were excluded due to insufficient coverage and their lack of representativeness for the populations in both the northern and southern models.
- The Panel requested further sensitivity analyses regarding the surveys. In the northern model, the exclusion of the contemporary longline data had little impact, leading to a recommendation to remove it.

- The index of abundance derived from the MRIP CPUE data was excluded from the assessment and was justified due to potential hyperstability. The reasoning for exclusion was reasonable.
- The stopnet survey's geographical scope was limited, with data collected from only one site, raising doubts about its representativeness for the entire coast (i.e., as an index for the stock as a whole). The justification provided was after the fact and did not contradict other sources in the assessment.

Regarding age data, a change in the Florida 183m haul seine survey (1997 to 2022) collection process meant age 0s were absent from marginal age compositions until 2010, which we know does not accurately reflect early age compositions. Based on simulation results and the model's response to excluding the early years, the Panel recommended removing them from the dataset used to generate indices. Conditional age-at-length compositions would not be affected similarly because the non-representation of age 0s in otolith samples was based on size. Small fish were deemed known to be age 0 and not requiring ageing.

The justification provided for excluding scale-based age data was inadequate, as these data may offer valuable insights. There is significant potential for scale age data from younger fish to contribute additional useful information. Moreover, while the SAS showed monthly comparisons as a reason for exclusion, there was insufficient evidence regarding the overall time series, shorter time periods, and spatial coverage.

The use of discard length composition data from angler tag releases was well-reasoned and clearly presented. Incorporating discard length data addressed a significant information gap that would not have been filled otherwise.

The assessment report and presentations during the review workshop documented significant effort by the SAS to describe the available datasets in detail, and was appreciated by the Panel. Many of the data streams are limited geographically and so it was important to understand how representative they may be of stock trends. Some surveys had changes in sampling distribution over their time series. Additional clarification about sampling heterogeneity for adult and subadult surveys was provided by the SAS during the review meeting.

Sample sizes for length composition data were well-described. Decisions on specifications for selectivity of both fishery dependent and fishery independent data were well-reasoned, given the available information, and justified appropriately by the SAS.

Otolith ageing accuracy was reported as high and without significant bias. Scale aging for younger age-classes (e.g., 1 to 3 year olds) was shown to be accurate but was increasingly biased for older fish.

Several surveys showed poor residual diagnostics during CPUE standardization. The standardization models are directly used to create indices of abundance, which were in turn used in all the assessment methods presented during the workshop. The Panel believed the residuals issue should be resolved to ensure reliable indices. This belief was supported during the workshop when the Panel requested and was presented with results of sensitivity analyses on the

southern SS model when using abundance indices derived from CPUE standardization models without any problematic residuals pattern. The test was conducted on the SC trammel net sub-adult index and on the SC longline contemporary adult index. The southern SS model was sensitive to the updated SC trammel sub-adult index. The Panel also noted the residual diagnostics (i.e., qq plots) on the various indices seemed to show a latitudinal pattern.

As a general recommendation for CPUE standardization and subsequent derivation of abundance indices, the Panel noted the importance of doing the following:

1. Proper consideration of changes in the spatio-temporal coverage or sampling design for each survey. This requires including some spatio-temporal effect in the model and/or any available variables to reflect changes.
2. Proper inclusion and treatment of variables that could define red drum “suitable habitat” (i.e., any static (e.g., depth) or dynamic (e.g., temperature, salinity) variables potentially affecting the underlying red drum abundance, as opposed to “catchability” variables that only describe effectiveness in catching red drum. If the habitat variable is dynamic, its effect should be properly included when deriving the abundance index.

Once all of the abundance indices satisfy the above recommendations, the SAS should check to ensure indices are consistent with each other for overlapping age classes/cohorts across surveys, to identify when signals in abundance trends and year class strengths may be different or similar.

3. **Evaluate the methods and models used to estimate population parameters (e.g., F, abundance) and reference points, including but not limited to:**
  - a. **If modeling approaches differ from those recommended during the Simulation Assessment, were these differences warranted and appropriate?**
  - b. **Evaluate the choice and justification of the preferred model(s). Was the most appropriate model (or model averaging approach) chosen given available data and life history of red drum?**
  - c. **Evaluate model parameterization and specification (e.g., choice of CVs, effective sample sizes, likelihood weighting schemes, calculation/specification of M, stock-recruitment relationship, choice of time-varying parameters, plus group treatment).**

During the workshop presentation, the SAS provided a summary table highlighting differences between the SS estimation models (for the northern and southern stocks) used during the Simulation Assessment and the ones used during the current assessment. All except for the choice of steepness value were appropriate. The steepness value was fixed in the SS model for both stocks due to the lack of data to inform estimation of the parameter. However, the analytical team decided to fix its value to 0.99 as opposed to 0.84 (as previously used in the Simulation Assessment based on the literature) and the decision felt arbitrary and ad-hoc. Moreover, the decision, as noted in the report, effectively resulted in there being no stock-recruit relationship in the model. For a strong assumption, such as no stock-recruit relationship, a clear, evidenced justification would need to be provided. A lower fixed value for steepness, as used in the Simulation Assessment, would probably be more appropriate.

Integrated analysis, here using SS, was appropriate given the range of data sources available, and multi-fleet nature of the red drum fisheries. The SS models performed well during simulation. For the southern stock, the developed SS model was the most appropriate method for estimating population parameters and reference points considered in the assessment. For the northern stock, a SS model with satisfactory performance was not able to overcome data deficiencies, although the Panel appreciates the considerable effort by the SAS to develop a working northern SS model. There was nothing to indicate the SS model was not appropriate to formulate. The Traffic Light Analysis (TLA) is an indicator-based approach that was informative across a suite of stock and fishery characteristics. The TLA uses a range of data and thus exhibits a similar spirit to the integrated analysis approach. The TLA was simulation tested and was an appropriate choice by the SAS given the performance of the SS model and the available options.

All 3 methods (SS, TLA and Skate) are reliant on having high quality time series of indices of abundance. The available time series were considered for the SS models, with fewer times series retained than were used in the simulation assessments. The time series exclusions were well justified but inclusions less so. The indices used in the data poor approaches (TLA and Skate) were the same as or similar to those used in the SS models, which was appropriate. However, the data poor methods directly used the recent index data to provide an interpretation of stock health. The SS models used other data to interpret the indices. A more rigorous evaluation of the quality of indices used by the data poor methods was warranted.

#### *Traffic Light Analysis (TLA):*

The rationale for using the TLA was to have a backup to the more quantitative modeling approach. Having a back-up approach to the SS assessment models provided an alternative status evaluation under conditions where an SS model failed to work or where there were concerns about model reliability. The TLA method relied heavily on the specification of a reference period. The TLA reference period appeared somewhat long, and was not well justified. The reference period was also based on previous assessments rather than the durations of available time series. Having an overly-long reference period increases the risk of including times when the stock and fishery were not in a good state. The process of determining optimized values for thresholds from simulations was clear. However, the threshold for the adult abundance indicator was adjusted in what seemed to be an arbitrary way. The rationale for changing the threshold was explained well but the choice of the scalar of 0.5 was not well justified. The reference period for the southern stock (1991-2013) was chosen based on previous assessment results. It would be preferable (and more generalizable) if the reference period could be chosen based on the available time series using robust criteria, rather than past assessment outputs which could be unreliable and/or not available in certain cases. Moreover, the optimized value of thresholds from the Simulation Assessment was arbitrarily adjusted for the adult abundance indicator used in the TLA. The rationale for the change was explained well but the choice of the scalar was not justified.

#### *Stock Synthesis Models:*

In general, the choices made by the SAS when developing the model parameterization and specifications were consistent with the available data and knowledge of the stock(s). Model parameterization and specifications were very well described. Extending the age structure of the estimation models compared to previous assessments allowed the analysts to take advantage of

information on growth of larger fish and relative strength of older year classes. The approach taken to specify, calculate, and estimate time-varying natural mortality, based on a growth-based Lorenzen was well documented and in line with best practices for stocks where M is believed to vary considerably over lifespan.

A notable change to models from past assessments was the change to fishing year from calendar year. This meant there was a need to make sure all data were shifted accordingly. This was feasible and done for relevant data sources. Choices for specifying time-varying retention in the recreational fishing fleets were aligned with known changes in regulations - a sensible approach that allowed for estimation of changes that influence discards, despite the limited direct information on discard length compositions in the recreational fisheries. Because of the data limitations, the SAS needed to fix some parameters of the selectivity and retention functions to ensure resultant selectivity ogives were consistent and plausible. The parameter choices were well described and reasonable.

Parameterization of the Beverton-Holt stock-recruit relationship was suboptimal. During simulation testing, steepness was an estimated parameter. However, when fit to the available data for the stock the SAS found that steepness was estimated at the upper bound. The SAS decided to fix steepness at the upper bound (1.00). The Panel noted better information for a potential fixed value of steepness was likely available, given that a value based on life-history information was used as the basis for the value in the simulation Operating Model. During the workshop, the Panel requested an additional sensitivity analysis using a fixed value of 0.84.

For the length composition data, the SAS assumed multinomial distributions. They did not consider alternative self-weighting distribution assumptions to the composition data (e.g., dirichlet) that are becoming more commonly applied for these types of models. The decisions for sample size for the length compositions appeared reasonable given available SS diagnostics. In the southern stock SS model, for the subadult surveys, there was some double use of data, by fitting the model to both length compositions and marginal age compositions, which are derived from the same data. The Panel recommended fitting to both length composition data and conditional age-at-length data, or fitting just to marginal age compositions, for a given index. The conditional age-at-length data appeared more robust to changes in sampling protocols over the time series for certain indices.

#### *Skate method:*

The Skate method is an alternative data limited approach, designed to provide a scaler for management action rather than a statement that action is required. Overall, the model parametrization of the Skate method was appropriate, though the method has been shown to perform poorly compared to alternatives (e.g., Legault et al. 2021). The SAS ensured that both key information sources - the abundance index and the catch time series - targeted the same age group, thereby ensuring consistency between the numerator and denominator in terms of unit measurement. The alignment ensured the focus remained on the primary younger segment of the population that was predominantly exploited by the fisheries. Additionally, employing a three-year moving average for both the catch and abundance index was suitable, as it helped emphasize the main trends while mitigating the effects of random fluctuations ("noise"). The reference point used in the Skate method was static and deemed appropriate for this type of

analysis. Nonetheless, the selection of the reference point - currently based on the median of the catch-to-index ratio over the available time series - appears somewhat arbitrary and could significantly influence catch recommendations. Despite the strengths of the data-limited approach, there are several weaknesses that warrant consideration:

- The method is sensitive to variations in year-class strength. As the catch-to-index indicator shifts from strong to weak year classes (or vice versa), there is a risk of overestimating or underestimating the catch advice. No adjustments have been proposed to address such variability.
- Furthermore, the method is susceptible to the "ratcheting" effect on catch advice, as the advice from one application is directly affected by the output of the previous timestep, even when trend indicators do not change. However, the use of a three-year moving average does reduce this impact.

Ideally, the performance of the skate method could have been tested within the simulation framework.

#### *Tagging models:*

A number of tagging models are potentially suitable for use with the available data. The Cormack-Jolly-Seber (CJS) model is a simple model but was appropriate to the data and purpose of the tagging program with respect to red drum. Background details on the main tagging studies used were presented by the SAS, with some key information needed for evaluation of the approach provided via discussion but not in the report. This included information on tag loss (tag shedding). In addition, other required information was discussed in general but the detailed data were not presented or evaluated. This included concerns from the Panel regarding possible gear-specific post-release mortality, with different gear types providing fish for tagging over different periods of the overall tagging program and the potential for undefined bias in the results. The model for survival was based on release age rather than age of fish. A multi-state model would address this. The Panel considered the visualization of annual apparent survival from the CJS analysis to be over-smoothed.

- 4. Evaluate the diagnostic analyses performed, including but not limited to:**
  - a. Sensitivity analyses to determine model stability and potential consequences of major model assumptions.**
  - b. Retrospective analysis.**

#### *Traffic Light Analysis:*

Sensitivity of output to alternative reference points was provided. 11 different reference periods were tested and changes in outputs were examined. However, details about each sensitivity test were not in the report. Sensitivity analysis results were largely in agreement with only the adult abundance, showing some disagreement with 4 cases requiring "moderate action" and 7 "no action" out of the 11 cases tested. Other sensitivity analyses were discussed during the meeting but nothing more was presented nor evaluated. The additional sensitivity analyses included: the use of updated abundance indices based on CPUE standardization without concerning residual patterns; changes in TLA thresholds due to changes in the assumed steepness; and possible inclusion of new scenarios (e.g., hyperstability/bias in the adult longline index) when evaluating



TLA thresholds. There was some opportunity for a historical retrospective for the TLA. However, it would likely be limited by the time series duration of key datasets.

*Stock Synthesis:*

The Stock Synthesis (SS) model diagnostic analyses were conducted in accordance with standard practices for stock synthesis models. The SAS team delivered a comprehensive presentation of the model diagnostics, including assessments of convergence, goodness-of-fit, sources of information and structure, and sensitivity analysis.

For the southern stock, the SAS presented several elements to demonstrate model convergence. Model structure was confirmed to be robust, as no parameters reached their bounds. Additionally, the final gradient was minimal ( $5.76014e-05$ ), with the Hessian matrix positive definite. These factors, along with jitter analysis, indicated the model successfully converged to a global solution. Further validation was provided through the presentation of additional convergence diagnostics, such as the parameter correlation matrix, that supported the convergence conclusions.

Residual analysis was employed, in an appropriate way, to assess the goodness-of-fit across indices of recruitment, sub-adult, adult, and composition data. The Francis plot was utilized to summarize goodness-of-fit to composition data, and deemed an appropriate choice. Although most residuals appeared random, the index residuals plot lacked the three residual standard deviation areas necessary for confirmation. Some residuals displayed biases and skewness, indicative of potential model misspecification. The Panel identified possible sources for these issues, particularly concerning index standardization. It was noted that while diagnostics for index standardization were discussed during presentations, upon request from an earlier meeting, they were not included in the report. Once presented, the indices revealed poor diagnostics, characterized by residual patterns and skewed QQ plot distributions. As mentioned above, the Panel recommended a more comprehensive diagnostic evaluation of residuals during index standardization.

The retrospective analysis of information sources and model structure was thorough, employing a six-year peel to monitor key reference point-related quantities, including spawning stock biomass (SSB), relative SSB, Age-2 fishing mortality, and Spawning Potential Ratio (SPR) estimates. The analysis revealed a minor retrospective pattern, with a three-year peel divergence attributed by the SAS to low 2019 index values, and suggested the indices warrant further scrutiny. Historical retrospective analysis demonstrated the model's performance relative to previous assessments.

A detailed sensitivity analysis was conducted for the SS southern model. The sensitivity of model results to data inclusion/exclusion was explored as part of model building, but not done with the final base model. No bridge runs from previous assessments were presented. The Panel thought this was acceptable given the substantial changes in models and data streams. A comparison of model result quantities to previous assessment estimates was provided, as detailed below. Despite the thoroughness of diagnostics, the Panel suggested including additional diagnostics from the SS cookbook. For instance, the SAS could have considered hindcasting cross-validation for indices, to provide insights on the model's capacity to predict future catches.

*Skate model:*

A sensitivity test based on the choice of terminal year was conducted. Other sensitivity analyses were discussed during the meeting but nothing more was presented nor evaluated. The additional sensitivity analyses included: the choice of the reference period to calculate the reference F value (instead of basing it off to the entire time series); the number of years to calculate the moving average; the use of weighted average; and the use of updated abundance indices based on CPUE standardization without concerning residual patterns. As the skate model was not being proposed as the basis for stock status determination, the Panel did not feel additional analysis here was warranted given the availability of other analyses.

**5. Evaluate the methods used to characterize uncertainty in estimated parameters. Ensure the implications of uncertainty in technical conclusions are clearly stated.***Traffic Light Analysis:*

Uncertainty in outputs was provided based on changes to the reference period. The chosen reference period is relatively long and may include years when the fishery was not performing optimally, which will tend to increase uncertainty. The concern could be reduced by selecting a shorter, well-justified reference period. The Panel suggested further future work to understand the robustness of outputs from the TLA, such as sampling from distributions of the alternative thresholds and number of year error rates.

The TLA uses a simulation framework developed in 2022 to determine the “reference values”. I.e., the threshold values and number of years to trigger management action. Values are based on many iterations and scenarios. In this sense, the determination of “reference values” clearly considers the uncertainty included in the operating model around the TLA inputs, as well as uncertainty around the population dynamics (i.e., different scenarios). Furthermore, the SAS conducted sensitivity analyses on the choice of reference period and determined there was no major change in status for the southern stock. Finally, the SAS utilized precautionary principles when defining the management reference points (i.e., overfishing and overfished) in terms of frequency of any indicator being red. However, the choice of reference points has not been fully evaluated using a simulation or management strategy evaluation approach. The Panel recommended doing so before establishing such reference points.

*Stock Synthesis:*

To characterize uncertainty in the SS model, SAS presented sensitivity analyses, likelihood profiles for  $R_0$ , and asymptotic standard errors, representing good practice. The selection of model elements for sensitivity runs was appropriate, aligning with previous review recommendations. While the sensitivity of model results to data inclusion or exclusion was considered during model development, it was not incorporated into the final base model. Though it was thorough, the Panel observed the sensitivity analysis was missing a test for steepness, set to 0.99, implying no stock-recruitment relationship, despite biological evidence suggesting otherwise. Consequently, during the meeting, the Panel requested an additional analysis with steepness set to 0.84, reflecting the biological analysis. The Panel also requested the following analyses: 1) the impact of removing the first 10 years of age 0 data (2000-2010) from the Florida

haul seine index, 2) the updated standardized South Carolina trammel index, 3) the removal of sub adult (SA) lengths, and 4) the adjustment of MRIP catch estimates combined with a 4% discard mortality, as well as the impact of increasing and decreasing natural mortality by 20%.

Plots of SPR, spawning stock biomass, and relative spawning stock biomass indicated that while most analyses resulted in proportional shifts, only the removal of the Florida haul index data and the update of the South Carolina trammel index led to a change in stock status. The exclusion of sub adult lengths also resulted in a noticeable change in the pattern of SSB and relative SSB estimates. Given these uncertainties, the Panel recommended the datasets be further investigated. The majority of the additional runs led to point estimates that lay within the 95% confidence interval of the proposed base model.

The log-likelihood profiles for R0 revealed the contribution of the total likelihood and of the component likelihood for each datasets. The analysis was done correctly and showed the model was mainly informed by the recruitment deviates, lengths, and discards, as they contributed the strongest to the log-likelihood profile. However, the total log-likelihood seems to be a trade-off between the model trying to fit the age composition data and the index, which highlighted data conflicts between the two sources.

*Skate model:*

The SAS appropriately used a moving average in the Skate analysis to focus on changes in trend while reducing the effect of noise. During the review workshop, the Panel also discussed the use of weighted moving average where the weight is based on the variability around the estimated annual index:catch ratio (i.e., inverse variance). The latter was not presented or evaluated during the workshop. Furthermore, the Panel noted an ad hoc characterization of sensitivity of the results to the reference period (including or excluding the 2022 fishing year). Further sensitivity on the choice of reference period (to calculate the “relative F”) was discussed during the meeting but was not presented nor evaluated during the meeting.

While there were no management reference points for the Skate method yet, the Panel recognized the value of performing a simulation analysis or a management strategy evaluation to evaluate the effectiveness of different harvest control rules and/or reference points if the Skate method is to be used to provide quantitative catch advice.

*Tagging models:*

Uncertainty in the tagging model estimates were provided using asymptotic standard errors.

**6. If a minority report has been filed, review minority opinion and any associated analyses. If possible, make recommendation on current or future use of alternative assessment approach presented in minority report.**

No minority report was filed.

**7. Recommend best estimates of stock biomass, abundance, and exploitation from the assessment for use in management, if possible, or specify alternative estimation methods.**

Northern stock: As there was no accepted SS model for the northern stock, either presented or developed during the review workshop, there are no model-derived usable estimates of biomass, abundance, or exploitation available.

However, the Panel believed the SS model should continue to be developed for potential future application to the northern red drum stock. Model development at a future benchmark assessment may be aided by longer time series of key datasets, especially for abundance indices.

The TLA Approach is interesting, though there are issues that need to be addressed, including robustness testing to understand choices:

- Reference period
- Indices reliability
- MSE performance (requires being able to tie TLA results to specific management actions)

The Panel agreed the TLA could be used as a qualitative indicator for northern stock status. This decision is strengthened by the weight of evidence from imperfect information coming from other analyses (increasing F from Skate, SS, etc.).

- We know recruitment is not a problem
- Based on the abundance indices, the adult index does not seem to have an issue overall
- Fishery Performance – we know there is an artifact because of the 2011 year class

For the index re-analyses that were completed, changes in trends are not extreme, but it is possible these could change enough for the value of an individual year's indicators to change.

Southern stock: For the southern stock, the Panel recommended the Stock Synthesis (SS) model be used as the primary basis for providing best estimates of stock biomass, abundance, and exploitation. The base model appears to be adequate, and additional analyses requested during the workshop indicated the model is generally conservative compared to the Traffic Light Analysis (TLA) and the Skate model. Notably, most of the sensitivity analyses requested during the review fell within the confidence interval of the base model and produced similar stock status outcomes.

While the model is currently performing well, the Panel has some reservations regarding certain input data, the index standardization process, and specific sensitivity analyses presented. Therefore, the Panel strongly recommends updating the following elements in the coming year to address concerns: 1) Revise the Index Standardization using the DHARMA package and explore residuals for potential spatio-temporal autocorrelation, 2) Update the catch history incorporating the latest data to improve model, 3) Consider dropping the longline contemporary survey. Addressing these issues will assist in refining the model, leading to more reliable advice for management of Atlantic red drum.

**8. Evaluate the choice of reference points and the methods used to estimate them. Recommend stock status determination from the assessment, or, if appropriate, specify alternative methods/measures.**

Northern stock:

There are a few reference points for SS models that are already established by the fishery management plan. They included F30% and SPR30% as thresholds and F40% and SPR40% as targets. The Fxx% were calculated based on age-2 fish and the level of F that achieved an SPRxx%. The SSBxx% represented the level of SSB associated with a stock fished at SPRxx%. SSB30% was the overfished limit and SSB40% was the target. However, the SSBxx% reference points are new and not yet part of the FMP. The reference points are seemingly acceptable on the basis of previous use for other stocks but have not been specifically evaluated for red drum stocks. The Panel therefore recommended the reference points be evaluated in the future using a simulation framework. That said, the SS3 model for the northern stock did not perform adequately for the basis of providing status advice.

The TLA approach also defined overfishing/overfished reference points based on experts' precautionary judgment. However, not enough information was provided to the Review Panel to fully evaluate their performance. The Panel therefore noted the reference points need to be evaluated in the future using a simulation framework.

Management reference points are not yet defined for the Skate method. However, the Panel recognized the value of performing a simulation analysis or a management strategy evaluation to evaluate the effectiveness of different harvest control rules and/or reference points if the Skate method was to be used to provide quantitative catch advice.

Southern stock:

The southern SS model used the same approach to reference point determination as proposed for the northern SS model, including for fishing intensity (F30% and SPR30% as thresholds and F40% and SPR40% as targets), and for stock size (SSB30% is the overfished limit and SSB40% is the target). The SSB reference point is new. Depending on how the biomass reference point is defined, it can be a function of the stock-recruitment relationship. There was some uncertainty from the presentation as to what quantities were being presented. Plots suggested SSB30% was the SSB at 30% of virgin biomass and not at F30% as suggested in the presentation. These quantities are identical only under the assumption of no stock recruitment relationship with steepness of 0.99.

Considerable effort had gone into including adult survey (longline) index in the assessment, so that stock status could be based on estimation of SSB. The Panel had some reservations on the estimation of SSB that created hesitancy regarding use of the index to derive reference points, because of the previously mentioned challenges as to whether the longline survey is effectively measuring changes in stock abundance of spawning fish. The models were relatively insensitive to the inclusion/exclusion of the longline data.

Reference points were calculated over the period 2019-2021. The Panel suggested it may be more appropriate to base reference points on the most up to date information, and that the SS model provide estimates for more recent windows (e.g., F could be 2020-2022, and SSB could

be 2021-2023). Changes to the years is unlikely to affect the stock status determination but may do so when stock is close to particular thresholds, as demonstrated in some of the uncertainty analyses when fit to revised indices.

**9. Review the research, data collection, and assessment methodology recommendations provided by the TC and make any additional recommendations warranted. Clearly prioritize the activities needed to inform and maintain the current assessment, and provide recommendations to improve the reliability of future assessments.**

The Review Panel generally supported the research recommendations from the TC. However, in the short/medium-term, there are a few additional topics the Panel recommended prioritizing.

*CPUE standardization*

First and foremost, the SAS needs to fix issues with the CPUE standardization as soon as possible. There are obvious problems with some of the CPUE analysis, and all indices of abundance need to be recomputed while making sure the underlying CPUE standardization does not show any residual pattern. Moreover, the SAS needs to make sure the derived indices properly account for the effect of all “habitat” covariates - both static and dynamic variables believed to affect the underlying biomass during the survey period – that are included in the final CPUE standardization model. The SAS then needs to perform a historical retrospective analysis examining changes in the assessment outputs and recommendation for all included models (i.e., SS, TLA, and Skate method).

*Utilize the simulation framework*

Secondly, the Review Panel believed the simulation framework developed in 2022 needs to be further utilized for testing/determining a variety of assessment relevant information, including:

- The determination of all red drum reference points. Instead of using values taken from the literature, the simulation framework can be used to tune in these reference points to the red drum case study. This includes the use of SPR30% and 40% reference points for the SS models, but also the definition of overfishing and overfished status for the TLA.
- A value of information analysis should be conducted to determine the value of each survey data source - both as indices of abundance but also the composition data – in order to prioritize data collection. The SS models had a hard time fitting to the longline survey indices of abundance in general. One can determine how much improvement in bias can be expected if one increases, for example, the age composition sample of the longline survey to its maximum capacity. Similarly, the simulation study could be used to determine whether the use of conditional age-at-length would be more useful than marginal age composition data.

*Tag recapture data*

The Review Panel also recommended the tagging studies be continued but, at the same time, ensure the necessary parameters for estimation of tag models (e.g., tagging mortality) be updated and continually monitored. During discussion, it was shown that the gear types from which tag data came from changed over time. Thus, there is a need to explore possible ‘gear type’ effects in

the CJS tagging model, or possibly conduct a field experiment to confirm differences in tagging mortality by gear type and gear.

#### *Assessment model development*

The Review Panel recommended further development of the assessment model, particularly the SS models. One possible area of exploration was to investigate the utility of seasonal population dynamics models within SS to deal with growth misspecification (i.e., seasonal change in growth) that cannot be overcome via a 'seasons as fleets' approach.

#### *Fishery dynamics and implementation measures*

Conduct research to understand how to implement measures that might come out of the advisory process, including understanding drivers of fishery dynamics, and exploring ways of delivering necessary reductions in F.

### **10. Review the timeframe for future assessments provided by the TC and recommend any necessary changes.**

Having the next Benchmark Assessment in 5 years time is appropriate. Given the identified issues in the SS assessment for the southern stock of red drum, we recommend an update to the SS assessment for the southern stock in 2025. This should incorporate:

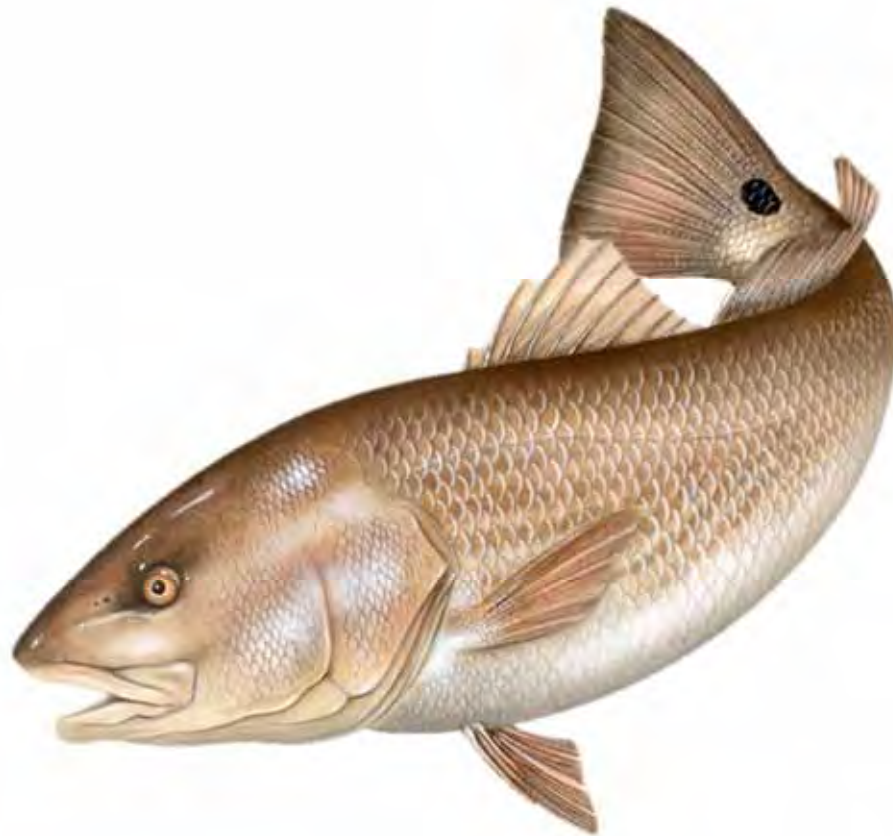
- The most recent data available, including catch, biological, and abundance indices information.
- Updating the model according to Panel recommendations, specifically including the approach to standardization of abundance indices and in the testing and selection of retained abundance indices.
- Expected changes in the catches derived from MRIP, if available.

The Panel recommended updating the TLA in the north in 2025 to incorporate the most up-to-date data. The 2 year update cycle is appropriate.

Consider re-running the southern stock SS assessment within the inter-benchmark period should the expected revision of catch history from MRIP be materially different (~30% reduction) from catches evaluated during the current assessment.

# Atlantic States Marine Fisheries Commission

## *2024 Red Drum Benchmark Stock Assessment Report*



Prepared by the  
ASMFC Red Drum Stock Assessment Subcommittee

And

Approved by the  
ASMFC Red Drum Technical Committee  
June 25, 2024



*Sustainable and Cooperative Management of Atlantic Coastal Fisheries*



**Prepared by the  
Red Drum Stock Assessment Subcommittee**  
Joseph (Joey) C. Ballenger, PhD, SCDNR, Chair  
Tracey Bauer, ASMFC  
Jared Flowers, PhD, GA DNR  
Angela Giuliano, MD DNR  
Jeff Kipp, ASMFC  
C.J. Schlick, PhD, SCDNR  
Ethan Simpson, VMRC  
Chris Swanson, FL FWC

and

**Red Drum Technical Committee**  
Ethan Simpson, VMRC, Chair  
Joseph (Joey) C. Ballenger, PhD, SCDNR  
Tracey Bauer, ASMFC  
Sarah Burnsed, FL FWC  
Matthew Jargowsky, MD DNR  
Chris Kalinowsky, GA DNR  
Jeff Kipp, ASMFC  
Cara Kowalchyk, NC DMF  
Devon Scott, DE REC  
Alissa Wilson, NJ DEP



A publication of the Atlantic States Marine Fisheries Commission pursuant to  
National Oceanic and Atmospheric Administration Award No.  
NA20NMF4740012.

## **ACKNOWLEDGEMENTS**

The Atlantic States Marine Fisheries Commission (ASMFC) thanks all of the individuals who contributed to the development of the 2024 Red Drum Benchmark Stock Assessment. The ASMFC specifically thanks members of the Red Drum Technical Committee (TC) and Red Drum Stock Assessment Subcommittee (SAS) who developed the consensus stock assessment report and ASMFC staff, Jeff Kipp and Tracey Bauer, for coordinating the assessment and completion of the report.

The TC and SAS would also like to acknowledge the following individuals for their support during the assessment: Anna-Mai Christmas-Svajdlenka (ACCSP) for validating and providing commercial landings data from partner agencies and Jimmy Kilfoil (SCDNR) for all his work developing the Cormack-Jolly-Seber tagging model.

## EXECUTIVE SUMMARY

The purpose of this assessment was to evaluate the status of red drum, as divided into two stocks (South Carolina/North Carolina (SC/NC) border north (northern stock) and SC/NC border south through the east coast of Florida (southern stock)), along the U.S. Atlantic Coast. This represents the third benchmark stock assessment of red drum conducted through the Southeast Data Assessment and Review (SEDAR) process, with previous assessments completed in 2009 (SEDAR 18; SEDAR 2009a) and 2015 (SEDAR 44; ASMFC 2017b; SEDAR 2015b). We aligned data sources with a fishing year definition (September 1 – August 31), a change in year definition relative to previous assessments. We calculated recreational dead discards assuming an 8% discard mortality rate, consistent with the previous benchmark and research. We defined the assessment period as 1981-2021, with preliminary fishing year 2022 data included when available, with stock status based on a terminal year of 2021.

### Northern Stock

#### *Removals*

##### Recreational Landings & Discards

The Marine Recreational Information Program (MRIP) provides northern stock recreational landings and discard data for red drum, with landings and discards aggregated for all states from North Carolina north along the Atlantic coast. Recreational removals (harvest + dead discards) exhibited a decrease in the early-1990s, with 3-year average annual removals declining from 0.39 million fish (1986-1988) to 0.12 million fish (1994-1996), before beginning to increase again in the late-1990s. Northern stock recreational removals have exceeded removals observed in the late-1980s since the late-2000s, peaking at 1.06 million fish removed annually from 2011-2013. In the terminal 3-years (2019-2021), annual recreational removals were 0.92 million fish.

The recreational fishery accounts for an increasing proportion of northern stock removals through time, accounting for greater than 90% of annual removals over the last ten years. These removals are increasingly represented by dead discards, averaging 37% of annual recreational removals over the last ten years.

##### Commercial Landings & Discards

The northern stock commercial fishery has two major components, a commercial gill net/beach seine fleet and a commercial other gears fleet. Additional landings data are available from a small-scale North Carolina (NC) recreational commercial gear license (RCGL) program, though these landings represent less than 1% of estimated landings annually. While no coastwide total allowable catch exists, North Carolina commercial landings have been subject to a commercial cap of 250,000 pounds (113.4 mt) since 1991.

Commercial fleet landings have been steady to decreasing, with a high degree of interannual variability, throughout the assessment period. Landings peaked in the late-1990s at a 3-year

average of 144 mt (1997-1999) though a 3-year minimum of 39 mt annually was observed only a few years later (2001-2003). From 2019-2021, annual landings were 78 mt.

Commercial dead discard data derives from an observer program for the North Carolina gill net fishery. Since peaking in the late-1990s (3-year average of 0.10 million fish (1997-1998)), discards have declined, with a 3-year average of 5,625 dead discards from 2019-2022.

### *Indices of Relative Abundance*

#### Recruitment (i.e., Young of the Year (YOY)) Index

The North Carolina Department of Marine Fisheries (NCDMF) bag seine survey, the only northern stock recruitment index, suggests an overall trend of stable to decreasing recruitment outside of the exceptionally strong 1991-, 1993-, and 2018-year classes.

#### Sub-Adult Index

The NCDMF gill net survey, the only northern stock sub-adult index, showed a variable trend over the time series, with the highest value occurring in 2012. The high value in 2012 was driven by the 2011-year class, as the survey primarily encounters age-1 and age-2 red drum.

#### Adult Index

The NCDMF adult red drum longline survey, the only northern stock adult index, indicates adult red drum abundance increased from the late-2000s through the mid- to late-2010s, with interannual variability. Relative abundance in 2019, 2021, and 2022 was lower than observed in other recent years and similar to the abundances observed in the late-2000s and early-2010s.

### *Assessment Models*

#### Stock Synthesis Model

We present two alternative stock synthesis (SS) models developed for the northern stock, with different assumptions regarding fleet selectivity. The “estimated selectivity model” freely estimated selectivity parameters for indices and fishing fleets, though the model proved extremely unstable, estimated unrealistically high recruitment deviations in the 1970s, possessed a narrow dome-shaped recreational selectivity contrary to expert opinion, and produced estimates of low initial fishing mortality (F) and trends in spawning stock biomass (SSB) that did not align with expectations of the history of the fishery through time. The “hybrid selectivity model” attempted to address model stability concerns by fixing the selectivity of the commercial gill net/beach seine and recreational fleet. This model estimated more realistic recruitment deviations in the 1970s and produced recreational selectivity estimates matching expert opinion, but still estimated low initial F and stock biomass trends that did not align with expectations of the history of the fishery while producing unrealistically low (approaching zero) spawning potential ratios (SPR) and extremely high F estimates.

We recommended not using either model for stock status information, instead using trends in F and SPR from the models as a complementary analysis to other assessment techniques. Both suggested an increasing trend in F and decreasing SPR throughout the assessment period.

#### Traffic Light Analysis Method

The assessment team used a fuzzy traffic light analysis (TLA) method to assess the northern stock using three indicators, recruitment, fishery performance, and adult abundance, using a 1996-2013 reference period. In the terminal year, the recruitment, fishery performance, and adult abundance indicators triggered moderate, moderate, and no action, respectively. Results suggest the northern stock is not experiencing overfishing (fishery performance indicator) nor is it overfished (adult abundance indicator). Multiple years of moderate action fishery performance triggers and an increasing frequency of moderate action recruitment triggers are consistent with increasing exploitation in recent years as suggested by the SS model.

#### Skate Data Limited Control Rule Method

We used the Skate data limited control rule method to produce F information and catch advice using a time series of catch and relative abundance data (NCDMF gill net survey) for the northern stock. The analysis uses a ratio of catch to relative abundance, with ratios exceeding relative F (median ratio over the time series) indicative of unsustainable fishing pressure. The northern stock catch:index ratio has increased throughout the time series, indicative of increasing F, exceeding relative F every year since 2015. Observed catch exceeded recommended catch in six of the past seven years, with an average reduction in catch of 23% needed from 2015-2021.

#### *Stock Status*

The northern stock SS model was not deemed useful for stock status determination. Based on the results of the TLA analysis, the northern stock is not experiencing overfishing and is not overfished though there is uncertainty given TLA results during the mid- to late-2010s are heavily influenced by the 2011 strong year class. All three analyses of the northern stock are suggestive of increasing F throughout the assessment period.

### **Southern Stock**

#### *Removals*

#### Recreational Landings & Discards

MRIP provides southern stock recreational landings and discard data for red drum, with landings and discards separated for South Carolina, Georgia, and Florida owing to differing management of the resource through time. Recreational removals (harvest + dead discards) initially decreased in each state from highs in the early- to mid-1980s. Trends then differ by state. In South Carolina, removals continue to decline through the 1990s, then increased through the 2000s and became stable at higher levels in the 2010s. Removals increased since

the 1980s in both Georgia and Florida, but at a greater rate in Florida. At the state level, removals in the late-2010s were at levels similar to the 1980s in all states, though removals in South Carolina and Florida were slightly lower than recent peaks in the 2020s.

When combined, removals exhibited a rapid decrease in the early-1980s, with 3-year average annual removals declining from 2.30 million fish (1983-1985) to 0.69 million fish (1988-1990). Since, removals have increased with southern stock recreational removals meeting and exceeding early-1980s removals since the early-2010s, peaking at a 3-year average of 2.55 million fish (2016-2018). From 2019-2021, annual removals were 1.66 million fish.

### Commercial Landings & Discards

Southern stock landings were highest during the 1950s, when all southern states made significant contributions to the landings, averaging 204,986 pounds from 1950-1956. Landings then declined to low, stable levels as the fishery contracted spatially to only Florida, averaging 136,333 pounds from 1957-1984. During the mid-1980s commercial fisheries faced tightening restrictions resulting in declining landings and a complete phase out by 1989. During the assessment period, landings are highest in 1981 at just over eighty-seven thousand fish and decline throughout the 1980s until the fishery was closed in 1989.

### *Indices of Relative Abundance*

For the southern stock, state fishery-independent surveys were used to develop ten indices of relative abundance representing red drum recruitment, sub-adult, and adult relative abundance indices. Owing to different selectivity patterns and gears, no indices representing similar life stages were combined into a coastwide index with independent selectivity estimated in the southern stock SS model.

### Recruitment (i.e., Young of the Year (YOY)) Indices

We developed three recruitment indices using data from the South Carolina Department of Natural Resources (SCDNR) rotenone survey, Georgia Department of Natural Resources (GADNR) gill net survey, and Florida Fish and Wildlife Commission (FL FWC) 21.3 m haul seine survey. The rotenone survey indicated above average recruitment in 1986, though a stable to decreasing trend in year class strength through time. The gill net and 21.3 m haul seine surveys overlap temporally, with both exhibiting high interannual variability. The gill net survey suggests the strongest year class occurred in 2021, though above average recruitment was also observed in 2001, 2003, 2008, and 2015. Below average recruitment was observed in 2004, 2010-2011, and 2018. The strongest year class identified by the 21.3 m haul seine occurred in 2012, followed by the 2021-year class; the only other above average year class occurred in 2007.

### Sub-Adult Indices

We developed four sub-adult indices using data from the SCDNR stop net, SCDNR electrofishing, SCDNR trammel net, and FL FWC 183 m haul seine surveys. We dropped the electrofishing survey from the SS model due to data conflicts identified early in the process. The stop net survey varied without trend, while the trammel net and 183 m haul seine surveys suggested similar, declining trends over the period of temporal overlap. The trammel net survey suggests a rapid decline in sub-adult abundance from the early-1990s through 1999, followed by higher abundances from 2000-2005. Since 2005, abundance decreased to an all-time low in 2019, followed by a recent marginal increase. Similarly, the 183 m haul seine survey suggests higher relative abundances in 2001-2005 and 2009-2010 (seen in trammel net survey also) within a decreasing trend through the late-2010s.

### Adult Indices

We developed three adult indices using data from the SCDNR historic adult red drum and shark longline, the SCDNR contemporary adult red drum and shark longline, and the GADNR longline surveys. We dropped both the historic longline and GADNR longline survey from the SS model due to data conflicts and poor model diagnostics, though the GADNR longline survey remained a component of the adult abundance indicator used in the TLA. The contemporary longline survey suggested stable to decreasing adult abundance, with low abundances in 2010-2011 and 2021-2022; 2009 was the only year with above average abundance.

### *Assessment Models*

#### Stock Synthesis Model

Recruitment deviations show random variation around time series average recruitment, though positive deviations in the 2010s were smaller than observed in earlier decades indicating reduced recruitment in recent years. The largest recruitment deviation of the assessment period was predicted for the 2022-year class, which had yet to recruit to fisheries.

Population numbers increased through the 1980s and early-1990s, fluctuated at variable but higher levels through the late-1990s and 2000s, before declining since 2010. Pulses of temporary abundance increases are notable in the early-1990s, early-2000s, and late-2000s.

Florida exhibited the highest F levels of the three fishing fleets, followed by South Carolina and Georgia. All fleets suggest increasing F since the 2000s with annual F peaking at or above early-1980s levels near the terminal year. Summary F, characterized by age-2 F, peaked in the early- to mid-1980s, decreased sharply in the late-1980s, and has followed an increasing trend through the late-2010s. Age-2 F decreased slightly in the last few years of the assessment, but remains elevated relative to the late-1980s through early-2010s.

High F led to SPRs below the management threshold of SPR30% in the early-1980s. SPR then increases above the threshold (and target of SPR40%) in the late-1980s, followed by a declining trend that falls below the threshold again in 2013. SPRs remain below the threshold for the remainder of the time series with a terminal three-year average SPR of 0.207.



We used SSB as the measure of reproductive output used to assess overfished conditions. SSB was low (<1,800 mt) through 1988, before gradually increasing through the mid- to late-2000s when SSB reached >10,500 mt. SSB began declining around 2010 with a terminal year SSB of 4,919 mt, the lowest estimate since 1991. Relative to SSB threshold (9,917 mt), SSB was well below the threshold at the start of the time series, first exceeding it in 1993. SSB then remained above the threshold through 2018, though it has continued a declining trend below since with a terminal 3-year average SSB of 8,737 mt (relative to threshold = 0.881).

Reference points for the model include F30%, SPR30% and SSB30% as thresholds and F40%, SPR40% and SSB40% as targets, where F30% and SPR30% denote overfishing and are established in the fishery management plan (FMP; ASMFC 2002). The Fxx% benchmarks are in terms of age-2 fish and is the level of F that achieves an SPRxx%. The SSB30% reference point represents the level of SSB associated with a stock fished at SPR30% and denotes overfished conditions. Stock status determinations are based on terminal three-year (2019-2021) averages of these reference points, using terminal life history characteristics, selectivity, and fleet-specific relative F.

Terminal Age-2 F (0.509) was above the F threshold (0.396) and F target (0.301), while SPR (0.207) was below SPR threshold (0.300) and SPR target (0.400). In addition, the stock is below the SSB target (13,250 mt) and SSB threshold (9,917 mt) with a terminal SSB of 8,737 mt. The southern stock of red drum stock status is overfished and experiencing overfishing.

#### Traffic Light Analysis Method

A southern stock TLA analysis used three indicators (recruitment, fishery performance, and adult abundance) relative to a 1991-2013 reference period. In the terminal year, the recruitment, fishery performance and adult abundance indicators triggered elevated, elevated and moderate actions, respectively. The elevated fishery performance and marginal adult abundance actions indicates the stock was experiencing overfishing but not overfished in the terminal year. However, given the difficulty of triggering the adult abundance indicator, we identified three additional TLA concerning trends in the stock that we recommended would trigger management action. All three were triggered, indicative of consistent below average recruitment, increasing catch and/or decreasing sub-adult abundance, and concerns regarding future adult abundance.

#### Skate Data Limited Control Rule Method

For the southern stock, we used two different catch:index ratios in our Skate analysis, one using SC recreational catch divided by a modified age-2 and -3 trammel net index and the other using FL recreational catch divided by the 183 m haul seine index. Both indicated the catch:index ratio has increased above relative F, exceeding relative F since 2010 and 2013 using the SC and FL data, respectively. This is indicative of increasing F, with observed catch exceeding recommended catch since 2010 and 2013 in SC and FL, respectively. Since 2012 (SC) and 2015 (FL), the Skate method suggests an average reduction of 66.9% and 47.6% of catch relative to the previous year would have been needed.

### Cormack-Jolly-Seber Tag-Recapture Model

We used a Cormack-Jolly-Seber tag-recapture model to estimate apparent survival using SCDNR tag-recapture data from the months of September-December annually. Apparent survival ( $\phi$ ) suggested decreasing mortality (age-1, age-2, & age-3+) through the 1990s to the early-2000s, followed by increasing mortality through the terminal year. If rates of age-specific emigration and natural mortality are assumed constant through time, changes in  $\phi$  are attributed to changing  $F$ , with  $F$  increasing since lows in the mid-2000s with terminal year  $\phi$  lower than observed in the early-1990s.

### *Stock Status*

We based our stock status determination for the southern stock on our SS base model, with a terminal year status of overfished and experiencing overfishing as terminal year 3-year average SPR and SSB were below management benchmarks. Overfishing has been occurring since 2014 while the stock was first determined to be overfished in 2020. The overfishing stock status determination is corroborated by the TLA analysis with increased exploitation of the stock since the late-2000s suggested by both the Skate method and Cormack-Jolly-Seber model.

## TABLE OF CONTENTS

TERMS OF REFERENCE .....	37
1 INTRODUCTION .....	44
1.1 Management Unit Definition .....	44
1.2 Regulatory and Management History .....	44
1.3 Assessment History .....	46
1.3.1 Regional Stock Assessments .....	46
1.3.2 Simulation Assessment .....	50
1.3.3 State Stock Assessments .....	54
1.3.4 Year Definition for Stock Assessment .....	56
2 LIFE HISTORY .....	57
2.1 Stock Definitions .....	57
2.2 Migration Patterns .....	59
2.3 Age and Growth .....	61
2.3.1 Maximum Age .....	62
2.3.2 Growth .....	62
2.4 Reproduction .....	64
2.4.1 Spawning Seasonality .....	64
2.4.2 Sexual Maturity .....	64
2.4.3 Sex ratio .....	66
2.4.4 Spawning Frequencies .....	66
2.4.5 Spawning Location .....	66
2.4.6 Batch Fecundity .....	67
2.4.7 Recruitment Drivers .....	67
2.5 Natural Mortality .....	69
3 HABITAT DESCRIPTION .....	70
3.1 Spawning, Egg, and Larval Habitat .....	70
3.2 Juvenile and Adult Habitats .....	72
3.3 Fish Habitat of Concern .....	75
4 FISHERY-DEPENDENT DATA SOURCES .....	75
4.1 Commercial Data .....	75
4.1.1 Data Collection and Treatment .....	75
4.1.2 Trends .....	82
4.1.3 Potential Biases, Uncertainty, and Measures of Precision .....	84
4.2 Recreational .....	84
4.2.1 Marine Recreational Information Program .....	84
4.2.2 Supplemental Recreational Sampling .....	91
4.3 Tagging Programs .....	95
4.4 Total Fishery Removals .....	100
5 FISHERY-INDEPENDENT DATA SOURCES .....	101
5.1 North Carolina Bag Seine Survey (NC_BagSeine) .....	101
5.1.1 Data Collection and Treatment .....	101
5.1.2 Trends .....	102
5.1.3 Potential Biases, Uncertainty, and Measures of Precision .....	102

5.2 North Carolina Independent Gill Net Surveys (NC_GillNet).....	102
5.2.1 Data Collection and Treatment.....	102
5.2.2 Trends.....	104
5.2.3 Potential Biases, Uncertainty, and Measures of Precision.....	104
5.3 North Carolina Adult Longline Survey (NC_Longline) .....	104
5.3.1 Data Collection and Treatment.....	104
5.3.2 Trends.....	106
5.3.3 Potential Biases, Uncertainty, and Measures of Precision.....	106
5.4 South Carolina Rotenone Survey (SC_Rotenone) .....	106
5.4.1 Data Collection and Treatment.....	106
5.4.2 Trends.....	108
5.4.3 Potential Biases, Uncertainty, and Measures of Precision.....	108
5.5 South Carolina Stop Net Survey (SC_StopNet) .....	109
5.5.1 Data Collection and Treatment.....	109
5.5.2 Trends.....	111
5.5.3 Potential Biases, Uncertainty, and Measures of Precision.....	112
5.6 South Carolina Trammel Net Survey (SC_Trammel) .....	112
5.6.1 Data Collection and Treatment.....	112
5.6.2 Trends.....	116
5.6.3 Potential Biases, Uncertainty, and Measures of Precision.....	116
5.7 South Carolina Historic Longline Survey (SC_Longline_historic).....	117
5.7.1 Data Collection and Treatment.....	117
5.7.2 Trends.....	119
5.7.3 Potential Biases, Uncertainty, and Measures of Precision.....	119
5.8 South Carolina Electrofishing Survey (SC_Electro) .....	119
5.8.1 Data Collection and Treatment.....	119
5.8.2 Trends.....	123
5.8.3 Potential Biases, Uncertainty, and Measures of Precision.....	123
5.9 South Carolina Contemporary Longline Survey (SC_Longline_contemporary).....	123
5.9.1 Data Collection and Treatment.....	123
5.9.2 Trends.....	127
5.9.3 Potential Biases, Uncertainty, and Measures of Precision.....	127
5.10 Georgia Gill Net Survey (GA_GillNet) .....	128
5.10.1 Data Collection and Treatment.....	128
5.10.2 Trends.....	130
5.10.3 Potential Biases, Uncertainty, and Measures of Precision.....	130
5.11 Georgia Longline Survey (GA_Longline) .....	130
5.11.1 Data Collection and Treatment.....	130
5.11.2 Trends.....	132
5.11.3 Potential Biases, Uncertainty, and Measures of Precision.....	132
5.12 Florida 21.3 Meter Haul Seine Survey (FL_21.3_HaulSeine).....	133
5.12.1 Data Collection and Treatment.....	133
5.12.2 Trends.....	134
5.12.3 Potential Biases, Uncertainty, and Measures of Precision.....	134

5.13 Florida 183 Meter Haul Seine Survey (FL_183_HaulSeine).....	134
5.13.1 Data Collection and Treatment.....	134
5.13.2 Trends.....	136
5.13.3 Potential Biases, Uncertainty, and Measures of Precision.....	136
6 METHODS.....	136
6.1 Cormack-Jolly-Seber Tagging Model .....	136
6.1.1 Background.....	136
6.1.2 Data .....	137
6.1.3 Model specification and selection .....	138
6.1.4 Results .....	138
6.2 Stock Synthesis Models .....	139
6.2.1 Background.....	139
6.2.2 Results .....	147
6.3 Traffic Light Analysis.....	157
6.3.1 Background.....	157
6.3.2 Framework and Optimization .....	158
6.3.3 Results .....	160
6.4 Skate Data Limited Control Rule Method .....	161
6.4.1 Background.....	161
6.4.2 Results .....	163
7 STOCK STATUS.....	164
8 FUTURE ASSESSMENTS AND RESEARCH RECOMMENDATIONS.....	166
9 REFERENCES .....	168
10 TABLES .....	183
11 FIGURES .....	259
12 Appendix A: Other data Sources considered.....	431
12.1 Fishery Dependent Data Sources .....	431
12.1.1 Commercial .....	431
12.1.2 Recreational .....	431

## LIST OF TABLES

Table 1.	Red drum regulation timeline by jurisdiction for the northern stock. ....	183
Table 2.	Red drum regulation timeline by jurisdiction for the southern stock. ....	184
Table 3.	Von Bertalanffy growth parameters estimated for red drum captured in North Carolina from north of the White Oak River (North), within and south of the White Oak River (South), and all individuals combined (Pooled). ....	185
Table 4.	Von Bertalanffy growth parameters estimated for red drum captured in North Carolina from within and south of the White Oak River (south), South Carolina (SC), and all individuals combined (Pooled).....	185
Table 5.	Number of ages of red drum sampled by year from the Atlantic coast of the U.S. from 1981 – 2022. ....	186
Table 6.	Number of red drum age samples collected by state within the Atlantic coast of the U.S. from 1981 – 2022. The variable ‘MULTI’ refers to several fishery independent surveys (e.g., ChesMMAP, NEAMAP) whose sampling universe spans multiple states; they operate in the northern stock. ....	187
Table 7.	Number of red drum age samples collected by fishery dependent and fishery independent sources on the Atlantic coast of the U.S. from 1981 – 2022.....	188
Table 8.	Length-at-maturity as estimated using logistic regressions fit to histologically derived maturity status information from South Carolina (SCDNR) and North Carolina (Ross et al. 1995 and NCDMF Study). Total lengths were measured to the nearest mm TL. As dta was only available from one state in each stock (South Carolina = Southern; North Carolina = Northern), these analyses represent maturity ogives for the respective stock. Parameters a and b ( $\pm$ SE) are for the logistic function $\text{Prop. Mat.} = \frac{e^{Z1} + e^Z}{1 + e^{Z1} + e^Z}$ where $Z = a + b \cdot \text{TL}$ . 50% maturity represents the total length where proportion mature equals 0.5 with 95% CI of estimate in parentheses. Also provided are the maturity ogives and 50% maturities as presented in SEDAR 44 for reference. ....	189
Table 9.	Age-at-maturity as estimated using logistic regressions fit to histologically derived maturity status information from South Carolina (SCDNR) and North Carolina (Ross et al. 1995 and NCDMF Study). Ages (in yrs) fit were age to the nearest month, assuming a September 1 birthday. As data was only available from one state in each stock (South Carolina = Southern; North Carolina = Northern), these analyses represent maturity ogives for the respective stock. Parameters a and b ( $\pm$ SE) are for the logistic function $\text{Prop. Mat.} = \frac{e^{Z1} + e^Z}{1 + e^{Z1} + e^Z}$ where $Z = a + b \cdot \text{Age}$ . 50% maturity represents the age where proportion mature equals 0.5 with 95% CI of estimate in parentheses. Also provided are the maturity ogives and 50% maturities as presented in SEDAR 44 for reference. ....	190

Table 10.	Predicted proportion mature by 20 mm TL bin for the southern and northern stock as estimated in SEDAR44 and the current assessment for female red drum.....	191
Table 11.	Predicted proportion mature by age for the southern and northern stock as estimated in SEDAR44 and the current assessment for female red drum. Note, this is proportion mature on a given birthday, which was assumed to be January 1 in SEDAR 44 and September 1 in the current assessment. This, along with the new data, led to a higher percentage of younger age red drum being mature in the current assessment.....	192
Table 12.	Number of actively spawning and mature females observed by SCDNR from mid-August through September and resultant probability of spawning, spawning frequency, and # of spawns assuming a 45-day spawning season for individual fish. Data was analyzed using only females captured in August, in September, and August and September combined...	192
Table 13.	Correlation results for North Carolina Bag Seine Survey recruitment index and favorable wind indices from North Carolina State Climate Office station KHSE. Significant results ( $p$ -value<0.05) are bolded and italicized.....	193
Table 14.	Correlation results for North Carolina Bag Seine Survey recruitment index and sea surface temperature indices from NOAA National Data Buoy Center Stations DSLN7 and 41025. ....	193
Table 15.	Correlation results for southern stock recruitment indices and favorable wind indices from NOAA National Data Buoy Center Stations 41004 (southeast of Charleston) and 41008 (southeast of Savannah). Significant results ( $p$ -value<0.05) are bolded and italicized. ....	193
Table 16.	Natural mortality-at-age, $M(a)$ , or -weight, $M(w)$ , of red drum in the northern ( $t_{max} = 62$ ) and southern ( $t_{max} = 41$ ) stocks. The ‘Mortality-weight’ model ( $M_w$ ) followed Lorenzen (1996). The ‘Length-inverse’ estimates of $M_L$ followed Lorenzen (2022) using the Hamel and Cope (2022) constant $M$ estimate. The ‘Length-inverse’ model scaled the cumulative mortality rate predicted for ages 2 – 62 and ages 2-41 to the longevity-based constant $M$ estimates for the northern and southern stocks, respectively. ....	194
Table 17.	Commercial gear categories developed and used in past red drum SEDAR stock assessments for ACCSP gear codes. ....	196
Table 18.	Commercial landings data collection methodology by state. ....	199
Table 19.	GLM estimated discards from the estuarine gill net fishery in North Carolina. ....	200
Table 20.	North Carolina red drum lengths obtained by year and gear from commercial fishery-dependent fish house sampling. ....	201
Table 21.	Number of commercial red drum harvested by gear and year from 1989 to 2022 in North Carolina. ....	202

Table 22.	Recreational commercial gill net landings from North Carolina from 1989 to 2022. ....	203
Table 23.	Florida red drum landings during the 1980s in numbers of fish (Murphy 2009). ....	204
Table 24.	Expanded catch-at-length for the major North Carolina commercial gears from 1989 to 2022. ....	205
Table 25.	Recreational red drum catch estimates (1,000s of fish) for the northern stock from MRIP. **2022 data are preliminary. ....	209
Table 26.	Recreational red drum catch estimates (1,000s of fish) for the southern stock from MRIP. **2022 data are preliminary. ....	210
Table 27.	Fishery-dependent biological samples collected via the SCDNR freezer, tournament, and state finfish surveys. ....	212
Table 28.	MGFTP guidance to anglers for tagging red drum throughout coastal South Carolina. ....	213
Table 29.	Number of recaptures as a function of years-at-large from the SCDNR conventional tagging program. ....	213
Table 30.	Indices of abundance for the northern red drum stock. Indices are scaled to their means and SEs are in terms of log(Index). ....	214
Table 31.	Indices of abundance for the southern red drum stock. Indices are scaled to their means and SEs are in terms of log(Index). ....	215
Table 32.	Fixed stations sampled by year as part of the SCDNR rotenone survey. Collections sites are arranged via estuary, from the South to the North. ....	216
Table 33.	Summary of life history information collected via the SCDNR during fishery-independent and fishery-dependent sampling program efforts. Bold #s represent years or sample sizes. Only sample sizes, by sex and maturity status where indicated, are provided for sex and maturity status. All lengths in mm, all weights in g, and all ages in yrs. Age-Length = ages determined based on length at capture and capture month; Age-Otolith = ages determined by otolith thin section aging techniques. ....	217
Table 34.	Size distribution by month of red drum encountered by the SCDNR rotenone survey. The year is aligned to start with August, the first month in which newly born red drum recruit to the gear in South Carolina. Green shaded cells represent age-0 red drum monthly throughout the year. Note, very few age-1+ red drum (denoted by pink shaded cells) are encountered by this survey, with those individuals only captured during the months of August and July. ....	218
Table 35.	SCDNR rotenone survey standardized index of year class relative abundance. RSE = relative standard error; lower and upper refer to the lower and upper bounds of a 95% CI as estimated using estimated marginal means. CPUE refers to the index on the catch scale; Relative abundance is	



	the index and confidence intervals normalized to the mean index value over all years of the survey.....	219
Table 36.	Fixed stations sampled by year as part of the SCDNR stop net survey. Collections sites are arranged via South Carolina estuary, from the South to the North. Note, year represents calendar year (Jan. 1 – Dec. 31) though the index was developed using fishing years (Sept. 1 – Aug. 31). Gray shaded cells are the years and sites considered for initial index development, prior to subsequent sub-sampling based on availability of other covariate information. ....	220
Table 37.	SCDNR stop net survey standardized index of relative abundance. RSE = relative standard error; lower and upper refer to the lower and upper bounds of a 95% CI as estimated using estimated marginal means. CPUE refers to the index on the catch scale; Relative abundance is the index and confidence intervals normalized to the mean index value over all years of the survey.....	221
Table 38.	Fishing years (and months within years) individual contemporary strata have been sampled as part of the SCDNR trammel net survey since 1990. Shaded cells include the years (and months) included in the development of relative abundance indices for individual species. ....	222
Table 39.	By fishing year, number of trammel net collections made in the contemporary strata. Shown is the total number of collections, including those not deemed suitable for index development but useful for collection of life history samples, and the number of collections retained for index development (in parentheses). ....	224
Table 40.	SCDNR trammel net survey standardized index of relative abundance. RSE = relative standard error; lower and upper refer to the lower and upper bounds of a 95% CI as estimated using estimated marginal means. CPUE refers to the index on the catch scale; Relative abundance is the index and confidence intervals normalized to the mean index value over all years of the survey.....	225
Table 41.	Fixed stations sampled by year as part of the SCDNR historic longline survey that were considered during index development. Collection sites are arranged from inshore to offshore North. Given the seasonal nature of the survey, collections made from August-December in a given calendar year (Year) was used to represent adult red drum abundance during that fishing year (e.g., fishing year = calendar year for survey).....	226
Table 42.	SCDNR historic longline survey standardized index of relative abundance. RSE = relative standard error; lower and upper refer to the lower and upper bounds of a 95% CI as estimated using estimated marginal means. CPUE refers to the index on the catch scale, in this case catch per 120 hooks; Relative abundance is the index and confidence intervals normalized to the mean index value over all years of the survey.....	227

Table 43.	Fishing years (and months within years) individual contemporary strata have been sampled as part of the SCDNR electrofishing survey since 2000. .....	228
Table 44.	By fishing year, number of electrofishing collections made in the contemporary strata.....	229
Table 45.	SCDNR electrofishing survey standardized index of relative abundance. RSE = relative standard error; lower and upper refer to the lower and upper bounds of a 95% CI as estimated using estimated marginal means. CPUE refers to the index on the catch scale, in this case catch per 15 minutes electrofishing; Relative abundance is the index and confidence intervals normalized to the mean index value over all years of the survey. ....	230
Table 46.	By year, number of SCDNR contemporary longline collections made. Shown is the total number of collections, including those not deemed suitable for index development but useful for collection of life history samples, and the number of collections retained for index development (in parentheses) by strata.....	231
Table 47.	SCDNR contemporary longline survey standardized index of relative abundance. RSE = relative standard error; lower and upper refer to the lower and upper bounds of a 95% CI as estimated using estimated marginal means. CPUE refers to the index on the catch scale, in this case catch per 120 hooks; Relative abundance is the index and confidence intervals normalized to the mean index value over all years of the survey. ....	232
Table 48.	Georgia Coastal Longline Survey sampling methodologies. November 2006 – December 2020. ....	233
Table 49.	Model structure of the 25 candidate models used to estimate apparent survival ( $\Phi$ ), and encounter probability ( $p$ ) for red drum tagged and released during fisheries-independent sampling by the South Carolina Department of Natural Resources from 1990-2022. The column 'MODEL' indicates the candidate model structure, including variables of age, time, sampling period, and constant probabilities ( $\sim 1$ ) as potential explanatory factors. NPAR indicates the number of parameters estimated in the corresponding model structure, and DELTA_AIC is the difference between that model's Akaike's information criterion value (AIC) and the lowest AIC value of all the candidate models.....	234
Table 50.	Length-length relationships estimated for red drum.....	235
Table 51.	Life history parameters used in SS models for red drum.....	236
Table 52.	Fishing mortality reference points and status measures for red drum analyses including the Stock Synthesis integrated model (SS), traffic light analysis (TLA), and Skate index-based method.....	236
Table 53.	Biomass and abundance reference points and status measures for red drum analyses including the Stock Synthesis integrated model (SS) and	

	traffic light analysis (TLA). Spawning stock biomass measures are in metric tons. ....	237
Table 54.	Configuration details for fishing fleets in the SS northern stock model.....	237
Table 55.	Configuration details for monitoring surveys in the SS northern stock model. ....	238
Table 56.	Retention block details for fishing fleets in the SS northern stock model. ....	238
Table 57.	Configuration details for fishing fleets in the SS southern stock model.....	239
Table 58.	Configuration details for monitoring surveys in the SS southern stock model. ....	239
Table 59.	Retention block details for fishing fleets in the SS southern stock model. ....	240
Table 60.	Life history and recruitment parameters for the northern stock SS estimated selectivity model.....	241
Table 61.	Fishing fleet initial fishing mortality, selectivity, retention, and discard mortality parameters for the northern stock SS estimated selectivity model. ....	242
Table 62.	Survey catchability coefficient and selectivity parameters for the northern stock SS estimated selectivity model.....	242
Table 63.	Jitter analysis results for the northern stock SS estimated selectivity model. The -LL column shows the change in total negative log-likelihood relative to the base model.....	243
Table 64.	Beginning of fishing year abundance estimates (in 1000s of fish) for the northern stock SS estimated selectivity model.....	244
Table 65.	Female spawning stock biomass estimates for the northern stock SS estimated selectivity model. 95% confidence intervals are based on asymptotic standard errors. ....	245
Table 66.	Age-2 fishing mortality (F) and spawning potential ratio (SPR) estimates for the northern stock SS estimated selectivity model. 95% confidence intervals are based on asymptotic standard errors. ....	246
Table 67.	Life history and recruitment parameters for the southern stock SS base model. ....	247
Table 68.	Fishing mortality parameter estimates for the southern stock SS base model. SC_Recreational, GA_Recreational, and FL_Recreational are fleets 1, 2, and 3, respectively.....	248
Table 69.	Fishing fleet initial fishing mortality, selectivity, retention, and discard mortality parameters for the southern stock SS base model. ....	249
Table 70.	Survey catchability coefficient and selectivity parameters for the southern stock SS base model. ....	250
Table 71.	Jitter analysis results for the southern stock SS model. The -LL column shows the change in total negative log-likelihood relative to the base model. ....	250

Table 72.	Beginning of fishing year abundance estimates (in 1000s of fish) for the southern stock SS base model. ....	251
Table 73.	Female spawning stock biomass estimates for the southern stock SS base model. 95% confidence intervals are based on asymptotic standard errors. ....	252
Table 74.	Age-2 fishing mortality (F) and spawning potential ratio (SPR) estimates for the southern stock SS base model. 95% confidence intervals are based on asymptotic standard errors. ....	253
Table 75.	Input data types for traffic light analysis characteristics selected for the red drum TLA framework and the stock status each characteristic is used to indicate.....	254
Table 76.	Data sources for each traffic light analysis characteristic selected for the red drum TLA framework. ....	254
Table 77.	Threshold values for the northern stock optimized from the grid square method. The estimated threshold for adult abundance, 0.78, was halved to serve as a more conservative metric for the assessment.....	254
Table 78.	Threshold values for the southern stock optimized from the grid square method. The estimated threshold for adult abundance, 0.78, was halved to serve as a more conservative metric for the assessment.....	254
Table 79.	Action results derived from the TLA model for the northern stock. The terminal fishing year used for stock status in the assessment is 2021. ....	255
Table 80.	Action results derived from the TLA model for the southern stock. The terminal fishing year used for stock status in the assessment is 2021. ....	255
Table 81.	Action results for the northern stock based on sensitivity runs evaluating changes in duration of reference period. A total of 8 different scenarios were evaluated. Results including the base reference period are in bold. ....	255
Table 82.	Action results for the southern stock based on sensitivity runs evaluating changes in duration of reference period. A total of 11 different scenarios were evaluated. Results including the base reference period are in bold. ....	255
Table 83.	NCDMF gill net survey red drum index (annual; 3-yr avg), MRIP North Carolina and areas north recreational harvest plus North Carolina commercial harvest (annual; 3-yr avg.), normalized catch:index ratio (CatchIndexnorm,y), recommended catch (CatchIndexnorm,y), and proportion change in catch relative to previous year as estimated using Skate methodology by fishing year. Bolded values indicate years with recommended catch reductions.....	256
Table 84.	SCDNR trammel net age-2 and -3 red drum index (annual; 3-yr avg), MRIP South Carolina recreational harvest (annual; 3-yr avg.), normalized catch:index ratio (CatchIndexnorm,y), recommended catch (CatchIndexnorm,y), and proportion change in catch relative to previous	

year as estimated using Skate methodology by fishing year. Bolded values indicate years with recommended catch reductions..... 257

Table 85.

FL FWRI 183 m haul seine red drum index (annual; 3-yr avg), MRIP Florida recreational harvest (annual; 3-yr avg.), normalized catch:index ratio (CatchIndexnorm,y), recommended catch (CatchIndexnorm,y), and proportion change in catch relative to previous year as estimated using Skate methodology by fishing year. Bolded values indicate years with recommended catch reductions..... 258

## LIST OF FIGURES

Figure 1.	Age frequency of red drum captured north of the White Oak River in North Carolina versus within and south of the White Oak River for ages 3+.....	259
Figure 2.	Fit of the von Bertalanffy age-length model to available biological data for red drum captured north of the White Oak River (black dots) and within or south of the White Oak River (red dots).....	259
Figure 3.	Age frequency of red drum captured in South Carolina and red drum captured south of the White Oak River in North Carolina for ages 3+.....	260
Figure 4.	Fit of Von Bertalanffy age-length model to available biological data for red drum captured in South Carolina (black dots) and red drum captured south of the White Oak River in North Carolina (red dots).....	260
Figure 5.	Cumulative proportion of tag recaptures as a function of straight line distance (km) and time-at-large. Time-at-large is split into 5 groups, 0-1 years (orange), 1-2 years (blue), 2-4 years (dark green), 4-6 years (brown), and 6+ years (light green). Fish were tagged as part of SCDNR’s Marine Gamefish Tagging and fishery-independent tagging programs. ....	261
Figure 6.	Age bias plot depicting the mean difference in scale - otolith derived ages for a given otolith derived age. Provided are the mean difference (symbol), 95% CI (black bars) and range of difference in age determinations (gray bars). Marginal histograms are provided showing the numbers of individuals given a particular age based on otolith (top histogram) and scale (right histogram) reads. ....	262
Figure 7.	Number of red drum age samples collected by stock/region (a.) and by state (b.) on the Atlantic coast of the U.S. from 1981 – 2022.....	263
Figure 8.	Number of red drum age samples collected by fishery dependent and fishery independent sources on the Atlantic coast of the U.S. from 1981 – 2022.....	264
Figure 9.	Scatterplot of the length-at-age by stock/region for red drum collected on the Atlantic coast of the U.S. from 1981 – 2022. ....	264
Figure 10.	Segmented regression on red drum biological mean length-at-age by stock. (a) northern and (b) southern.....	265
Figure 11.	Red drum length-at-age data collected from the northern stock of the Atlantic coast of the U.S. (a) the age-varying <i>K</i> growth model (blue line) as applied to the red drum length-at-age data and (b) the residuals from the model fit to the length-at-age data. ....	266
Figure 12.	Red drum length-at-age data collected from the southern stock of the Atlantic coast of the U.S. (a) the age-varying <i>K</i> growth model (blue line) as applied to the red drum length-at-age data and (b) the residuals from the model fit to the length-at-age data. ....	267

Figure 13.	Best fit length-at-maturity ogives for female (left panels) and male (right panels) red drum from the southern (bottom panels; solid blue line) and northern (upper panels; solid orange line) stocks. Shaded regions represent 95% confidence interval about the ogive. Dashed lines are the maturity ogives presented in SEDAR 44. Red dots are maturity (0 = immature; 1 = mature) of individual fish and gold triangles represent observed proportion mature by 20 mm TL bin.....	268
Figure 14.	Best fit length-at-maturity ogives for female (left panel) and male (right panel) red drum from the southern (solid blue line) and northern (solid orange line) stocks. Shaded regions represent 95% confidence interval about the ogive. Dashed lines are the maturity ogives presented in SEDAR 44. ....	269
Figure 15.	Best fit age-at-maturity ogives for female (left panels) and male (right panels) red drum from the southern (bottom panels; solid blue line) and northern (upper panels; solid orange line) stocks. Shaded regions represent 95% confidence interval about the ogive. Dashed lines are the maturity ogives presented in SEDAR 44. Red dots are maturity (0 = immature; 1 = mature) of individual fish and gold triangles represent observed proportion mature by age bin.....	270
Figure 16.	Best fit age-at-maturity ogives for female (left panel) and male (right panel) red drum from the southern (solid blue line) and northern (solid orange line) stocks. Shaded regions represent 95% confidence interval about the ogive. Dashed lines are the maturity ogives presented in SEDAR 44.....	271
Figure 17.	Batch fecundity estimates of female red drum based on the FWRI data set available from Tampa Bay, FL (orange dots) along with a fitted linear regression model (green line) and 95% confidence intervals (dark shaded region) and 95% prediction intervals (light shaded region) for the range of sizes with positive fecundity estimates (based on the model) and non-zero probability of a female being mature based on the Atlantic southern stock length-at-maturity ogive developed for this assessment. ....	272
Figure 18.	North Carolina Bag Seine Survey recruitment index and seasonal favorable wind index from North Carolina State Climate Office station KHSE.....	273
Figure 19.	South Carolina Trammel Net Survey age-1 index lagged back one year and early September favorable wind index from NOAA National Data Buoy Center Station 41004 southeast of Charleston. ....	273
Figure 20.	Georgia Gill Net Survey age-0 fishing year index and early August favorable wind index from NOAA National Data Buoy Center Station 41008 southeast of Savannah. ....	274
Figure 21.	Northern (green lines) and southern (gold lines) externally derived natural mortality estimates based on stock-specific maximum age and either weight-based M-at-age (dashed lines; Lorenzen 1996) or length-based M-at-age (solid lines; Lorenzen 2022). ....	274

Figure 22.	Estimated red drum discards in numbers based on North Carolina estuarine gill net observer program. ....	275
Figure 23.	Total commercial landings of northern stock red drum by the commercial gill net and beach seine (GNBS) fleet. Confidential data have been removed from the data set. ....	276
Figure 24.	Total commercial landings of northern stock red drum by the commercial other gear fleet. Confidential data have been removed from the data set. ...	276
Figure 25.	Total commercial landings of northern stock red drum. Confidential data have been removed from the data set. ....	277
Figure 26.	Total commercial landings of southern stock red drum. Confidential data have been removed from the data set. ....	277
Figure 27.	Annual length distributions of red drum landed by the North_Commercial_GNBS fleet. ....	278
Figure 28.	Annual length distributions of red drum landed by the North_Commercial_Other fleet. ....	279
Figure 29.	Annual length distributions of red drum discarded by the North_Commercial_GNBS fleet. ....	280
Figure 30.	MRIP recreational catch estimates of red drum from the northern stock. Dead discards are calculated with an assumed 8% discard mortality of releases. **2022 data are preliminary. ....	281
Figure 31.	Proportional standard error of MRIP recreational catch estimates of red drum from the northern stock. **2022 data are preliminary. ....	282
Figure 32.	MRIP recreational catch estimates of red drum from the northern stock with 95% confidence intervals (shaded regions). Dead discards are calculated with an assumed 8% discard mortality of releases and confidence intervals are calculated assuming the same PSEs as for released alive estimates. **2022 data are preliminary. ....	283
Figure 33.	MRIP recreational catch estimates of red drum from the southern stock. Dead discards are calculated with an assumed 8% discard mortality of releases. **2022 data are preliminary. ....	284
Figure 34.	Proportional standard error of MRIP recreational catch estimates of red drum from the southern stock. **2022 data are preliminary. ....	285
Figure 35.	MRIP recreational catch estimates of red drum from southern stock states with 95% confidence intervals (shaded regions). Dead discards are calculated with an assumed 8% discard mortality of releases and confidence intervals are calculated assuming the same PSEs as for released alive estimates. **2022 data are preliminary. ....	286
Figure 36.	MRIP recreational total removal estimates of red drum from the northern stock with 95% confidence intervals (shaded regions). Dead discards are calculated with an assumed 8% discard mortality of releases and	



	confidence intervals are calculated assuming the same PSEs as for released alive estimates. **2022 data are preliminary.....	287
Figure 37.	Proportional standard error of MRIP recreational total removal estimates of red drum from the northern stock (assuming released alive and dead discard PSEs are equal). **2022 data are preliminary.....	287
Figure 38.	MRIP recreational total removal estimates of red drum from the southern stock with 95% confidence intervals (shaded regions). Dead discards are calculated with an assumed 8% discard mortality of releases and confidence intervals are calculated assuming the same PSEs as for released alive estimates. **2022 data are preliminary.....	288
Figure 39.	Proportional standard error of MRIP recreational total removal estimates of red drum from the southern stock (assuming released alive and dead discard PSEs are equal). **2022 data are preliminary.....	288
Figure 40.	Ratios of wave 1 to waves 2-6 MRIP catch estimates from North Carolina for years when wave 1 catch estimates are available. Dashed horizontal lines show medians of annual ratios.....	289
Figure 41.	Ratios of wave 1 to waves 2-6 MRIP catch estimates from Georgia for years when wave 1 catch estimates are available. Dashed horizontal lines show medians of annual ratios. Due to a median of zero for released alive estimates, the harvest ratio ( $\approx 0.04$ ) was used for the released alive estimates and overlaps in this figure.....	290
Figure 42.	Wave 1 recreational catch estimates of red drum from North Carolina provided by MRIP and imputed with ratios of wave 1 to waves 2-6 MRIP catch estimates. ....	291
Figure 43.	Wave 1 recreational catch estimates of red drum from Georgia provided by MRIP and imputed with ratios of wave 1 to waves 2-6 MRIP catch estimates.....	292
Figure 44.	Ratios of wave 1 to waves 2-6 State Finfish Survey catch frequencies from South Carolina. Dashed horizontal lines show medians of annual ratios.....	293
Figure 45.	Wave 1 recreational catch estimates of red drum from South Carolina provided by MRIP and imputed with ratios of wave 1 to waves 2-6 State Finfish Survey catch frequencies. ....	294
Figure 46.	MRIP size composition estimates of recreational red drum harvest from the northern stock. **2022 data are preliminary.....	295
Figure 47.	MRIP size composition estimates of recreational red drum harvest from the northern stock aggregated by regulation periods. **2022 data are preliminary. ....	296
Figure 48.	Number of MRIP primary sampling units that encountered red drum in the northern stock for length measurements (effective) and number of individual red drum measured for length (raw). **2022 data are preliminary. ....	297

Figure 49.	MRIP size composition estimates of recreational red drum harvest from South Carolina in the southern stock. **2022 data are preliminary.....	298
Figure 50.	MRIP size composition estimates of recreational red drum harvest from Georgia in the southern stock. **2022 data are preliminary. ....	299
Figure 51.	MRIP size composition estimates of recreational red drum harvest from Florida in the southern stock. **2022 data are preliminary.....	300
Figure 52.	MRIP size composition estimates of recreational red drum harvest from South Carolina aggregated by regulation periods. **2022 data are preliminary. ....	301
Figure 53.	MRIP size composition estimates of recreational red drum harvest from Georgia aggregated by regulation periods. **2022 data are preliminary. ....	302
Figure 54.	MRIP size composition estimates of recreational red drum harvest from Florida aggregated by regulation periods. **2022 data are preliminary.....	303
Figure 55.	Number of MRIP primary sampling units that encountered red drum in the southern stock for length measurements (effective) and number of individual red drum measured for length (raw). **2022 data are preliminary. ....	304
Figure 56.	Size distributions of red drum tagged by volunteer anglers participating in the North Carolina Fish Tagging Program and Virginia Game Fish Tagging Program. Horizontal dashed lines indicate slot sizes in place in North Carolina and Virginia in recent years. ....	305
Figure 57.	Size distributions of red drum tagged by volunteer anglers and recaptured and subsequently released by anglers participating in the Virginia Game Fish Tagging Program. Horizontal dashed lines indicate slot sizes in place in North Carolina and Virginia in recent years. ....	306
Figure 58.	Size distributions of red drum tagged by volunteer anglers participating in the Virginia Game Fish Tagging Program and of harvested red drum from MRIP estimates for the northern stock. Horizontal dashed lines indicate slot sizes in place in North Carolina and Virginia in recent years.....	307
Figure 59.	Size distributions of red drum tagged by volunteer anglers and recaptured and subsequently released by anglers participating in the South Carolina Marine Game Fish Tagging Program from 1989-2000. Horizontal dashed lines indicate slot size in place in South Carolina in recent years. ....	308
Figure 60.	Size distributions of red drum tagged by volunteer anglers and recaptured and subsequently released by anglers participating in the South Carolina Marine Game Fish Tagging Program from 2011-2021. Horizontal dashed lines indicate slot size in place in South Carolina in recent years. ....	309
Figure 61.	Size distributions of red drum tagged by volunteer anglers participating in the South Carolina Marine Game Fish Tagging Program and of harvested red drum from MRIP estimates for South Carolina from 1989-1992 and	

	2011-2021. Horizontal dashed lines indicate slot sizes in place in South Carolina in recent years. ....	310
Figure 62.	Size distributions of red drum tagged by volunteer anglers and recaptured and subsequently released by anglers participating in the Georgia Cooperative Angler Tagging Project. Horizontal dashed lines indicate slot size in place in Georgia in recent years. ....	311
Figure 63.	Size distributions of red drum tagged by volunteer anglers participating in the Georgia Cooperative Angler Tagging Project and of harvested red drum from MRIP estimates for Georgia from 2018-2021. Horizontal dashed lines indicate slot sizes in place in Georgia. ....	312
Figure 64.	Size distributions of released red drum reported through the iAngler phone application and of harvested red drum from MRIP estimates for Florida. Horizontal dashed lines indicate slot sizes in place in Florida. ....	313
Figure 65.	Reported red drum captured during waves 2-6 (March – December; blue bars) and wave 1 (January – February; orange bars) by anglers participating in the SCDNR SFS. ....	314
Figure 66.	Proportion of red drum released during wave 1 (January – February) and waves 2-6 (March – December) as observed in the SCDNR SFS. Shown are the annual estimates (solid, heavy lines) along with a LOESS smoother of annual estimates with 95% confidence intervals (solid, thin lines with surrounding shaded region). ....	314
Figure 67.	From top to bottom, the tags above are: Stainless steel anchor “shoulder” dart tags and internal anchor “belly” tags with disk wired to streamer. ....	315
Figure 68.	Number of red drum tagged annually in South Carolina by tagging program. ....	315
Figure 69.	Number of red drum recaptured annually originally tagged as part of SCDNR's conventional tagging program. ....	316
Figure 70.	Proportion of recaptures released annually for fish tagged as part of the SCDNR conventional tagging programs. ....	316
Figure 71.	Tag year and recapture year of the >47,800 recaptures of fish tagged as part of the SCDNR conventional tagging program. ....	317
Figure 72.	Total fishery removals of northern stock red drum. Stacked area removals are numbers of fish and stacked line removals are metric tons. ....	317
Figure 73.	Total fishery removals (stacked area) of southern stock red drum. ....	318
Figure 74.	Sampling sites of the North Carolina Bag Seine Survey (NC_BagSeine) ....	318
Figure 75.	North Carolina Bag Seine Survey (NC_BagSeine) relative abundance, standardized to its mean, from 1991-2022. Error bars are $\pm$ one standard error. ....	319
Figure 76.	Map of Pamlico Sound and associated rivers showing the sample strata and locations of individual samples taken in the North Carolina Independent Gill Net Survey (NC_GillNet) from 2001 to 2006. ....	319

Figure 77.	Length compositions of red drum captured during the North Carolina Independent Gill Net Survey (NC_GillNet).....	320
Figure 78.	North Carolina Independent Gill Net Survey (NC_GillNet) relative abundance, standardized to its mean, from 2003-2022. Error bars are $\pm$ one standard error. ....	321
Figure 79.	The random grid system and sample regions used in the North Carolina red drum Longline Survey used from 2007 to 2022. The numeric value in each grid designates it to one of the twelve regions sampled. ....	321
Figure 80.	North Carolina Adult Longline Survey (NC_Longline) relative abundance, standardized to its mean, from 2007-2022. Error bars are $\pm$ one standard error. ....	322
Figure 81.	Length compositions of red drum captured during the North Carolina Adult Longline Survey (NC_Longline). ....	323
Figure 82.	Age distribution of red drum captured during the North Carolina Adult Longline Survey (NC_Longline). ....	324
Figure 83.	Frequency of individuals by year class (cohort) collected in the North Carolina Adult Longline Survey (NC_Longline) from 2007 to 2019. ....	325
Figure 84.	Length distribution, based on calendar year (Jan. 1 – Dec. 31), ageing methodology, and day of year of sampling, of red drum encountered by the SCDNR fishery-independent and fishery-dependent sampling programs. Ages are based on biological age, assuming a September 1 birthday. Note, any fish with age determined using scales have been omitted.....	325
Figure 85.	South Carolina Rotenone Survey (SC_Rotenone) relative abundance, standardized to its mean, from 1986-1993. Error bars are $\pm$ one standard error. ....	326
Figure 86.	Length composition of red drum encountered by the South Carolina Stop Net Survey (SC_StopNet) when pooled across all years. ....	326
Figure 87.	Age composition of red drum encountered by the South Carolina Stop Net Survey (SC_StopNet) when pooled across all years. Age 4 represents an age-4+ group. ....	327
Figure 88.	South Carolina Stop Net Survey (SC_StopNet) relative abundance, standardized to its mean, from 1987-1993. Error bars are $\pm$ one standard error. ....	327
Figure 89.	Annual length compositions developed for the South Carolina Stop Net Survey (SC_StopNet).....	328
Figure 90.	Annual age compositions developed for the South Carolina Stop Net Survey (SC_StopNet). Note, age represents biological age assuming a September 1 birthday and age-4 represents a ‘plus’ group.....	329
Figure 91.	Sampling distribution of the South Carolina Trammel Net Survey (SC_Trammel; red shaded areas), South Carolina Electrofishing Survey	

	(SC_Electro; purple shaded areas) and South Carolina Contemporary Longline Survey (SC_Longline_contemporary; green shaded areas) surveys. Also identified are two additional contemporary fishery-independent finfish surveys that do not regularly encounter red drum, SCDNR's COASTSPAN (gray shaded areas) and estuarine trawl (blue shaded areas) surveys. Identified are the five major South Carolina estuaries, from Port Royal Sound in the south to Winyah Bay in the north. ....	330
Figure 92.	Length composition of red drum encountered by the South Carolina Trammel Net Survey (SC_Trammel) when pooled across all years.....	331
Figure 93.	Age composition of red drum encountered by the South Carolina Trammel Net Survey (SC_Trammel) when pooled across all years. Age 5 represents an age 5+ group.....	331
Figure 94.	South Carolina Trammel Net Survey (SC_Trammel) relative abundance, standardized to its mean, from 1991-2022. Error bars are $\pm$ one standard error. ....	332
Figure 95.	Annual length compositions developed for the South Carolina Trammel Net Survey (SC_Trammel).....	333
Figure 96.	Annual age compositions developed for the South Carolina Trammel Net Survey (SC_Trammel). Note, age represents biological age assuming a September 1 birthday and age-5 represents a 'plus' group.....	334
Figure 97.	Fixed stations sampled as part of the South Carolina Historic Longline Survey (SC_Longline_historic) conducted by the SCDNR from 1994-2006 near Charleston, SC. The five fixed stations considered for index development are outlined by red circles. ....	335
Figure 98.	Length composition of red drum encountered by the South Carolina Historic Longline Survey (SC_Longline_historic) when pooled across all years. ....	336
Figure 99.	South Carolina Historic Longline Survey (SC_Longline_historic) relative abundance, standardized to its mean, from 1994-2006. Error bars are $\pm$ one standard error. ....	336
Figure 100.	Annual length compositions developed for the South Carolina Historic Longline Survey (SC_Longline_historic).....	337
Figure 101.	Length composition of red drum encountered by the South Carolina Electrofishing Survey (SC_Electro) when pooled across all years. ....	338
Figure 102.	Age composition of red drum encountered by the South Carolina Electrofishing Survey (SC_Electro) when pooled across all years. Age 4 represents an age 4+ group.....	338
Figure 103.	South Carolina Electrofishing Survey (SC_Electro) relative abundance, standardized to its mean, from 2001-2022. Error bars are $\pm$ one standard error. ....	339

	Total Length (cm)	
	.....	340
Figure 104.	Annual length compositions developed for the South Carolina Electrofishing Survey (SC_Electro).....	340
Figure 105.	Annual age compositions developed for the South Carolina Electrofishing Survey (SC_Electro). Note, age represents biological age assuming a September 1 birthday and age-4 represents a 'plus' group.....	341
Figure 106.	Length composition of red drum encountered by the South Carolina Contemporary Longline Survey (SC_Longline_contemporary) when pooled across all years. ....	342
Figure 107.	Age composition of red drum encountered by the South Carolina Contemporary Longline Survey (SC_Longline_contemporary) when pooled across all years using either raw, randomly selected aged fish (orange) and the best fit proportional odds logistic regression model (green).....	343
Figure 108.	Year class composition of red drum encountered by the South Carolina Contemporary Longline Survey (SC_Longline_contemporary) when pooled across all years using either raw, randomly selected aged fish (orange) and the best fit proportional odds logistic regression model (green).....	343
Figure 109.	SCDNR South Carolina Contemporary Longline Survey (SC_Longline_contemporary) relative abundance, standardized to its mean, from 2007-2022. Error bars are $\pm$ one standard error. ....	344
Figure 110.	Annual length compositions developed for the South Carolina Contemporary Longline Survey (SC_Longline_contemporary). ....	345
Figure 111.	Annual age compositions developed for the South Carolina Contemporary Longline Survey (SC_Longline_contemporary) using either raw, randomly selected aged fish (orange) and the best fit proportional odds logistic regression model (green). ....	346
Figure 112.	Annual year class compositions developed for the South Carolina Contemporary Longline Survey (SC_Longline_contemporary) using either raw, randomly selected aged fish (orange) and the best fit proportional odds logistic regression model (green).....	347
Figure 113.	Coastal Georgia counties with approximate Wassaw Sound and Altamaha River system sample areas. ....	348
Figure 114.	Sample areas for Altamaha River System. ....	349
Figure 115.	Sample areas for Wassaw Sound.....	350
Figure 116.	Georgia Gill Net Survey (GA_GillNet) relative abundance, standardized to its mean, from 2002-2022. Error bars are $\pm$ one standard error.....	350
Figure 117.	Georgia Longline Survey (GA_Longline) relative abundance, standardized to its mean, from 2006-2022. Error bars are $\pm$ one standard error. ....	351
Figure 118.	Length compositions of red drum captured during the Georgia longline survey (GA_Longline).....	352

Figure 119.	Florida 21.3 Meter Haul Seine Survey (FL_21.3_HaulSeine) relative abundance, standardized to its mean, from 2001-2021. Error bars are $\pm$ one standard error. ....	353
Figure 120.	Florida 183 Meter Haul Seine Survey (FL_183_HaulSeine) relative abundance, standardized to its mean, from 2001-2021. Error bars are $\pm$ one standard error. ....	353
Figure 121.	Length compositions of red drum captured during the Florida 183 Meter Haul Seine Survey (FL_183_HaulSeine). ....	354
Figure 122.	Age distribution of red drum captured during the Florida 183 Meter Haul Seine Survey (FL_183_HaulSeine).....	355
Figure 123.	Annual apparent survival estimates of red drum from a Cormack-Jolly-Seber mark-recapture model developed using conventional tagging data from the South Carolina Department of Natural Resources' fisheries-independent monitoring programs. Data include releases from 1990-2021, with recaptures from 1990-2022. A) Annual apparent survival estimates are a function of red drum age + time. B) Annual apparent survival estimates are a function of red drum age + s(time). ....	356
Figure 124.	Relative error for southern SS EM three-year F ratio estimates (a), mature female number estimates (b), and subadult number estimates (c) from the Base scenario (data with observation error), no observation error data with the Base scenario model (No Obs Error), and no observation error data with the Base scenario and correctly specified growth and natural mortality (No Obs Error TruGrowM). The black dashed line indicates no error. ....	357
Figure 125.	Data time series used in SS estimated selectivity model for the northern stock. ....	358
Figure 126.	Data time series used in SS base model for the southern stock. ....	359
Figure 127.	Observed and estimated catches for the North_Commercial_GNBS fleet for the northern stock SS estimated selectivity model (top) and hybrid selectivity model (bottom). ....	360
Figure 128.	Observed and estimated catches for the North_Commercial_Other fleet for the northern stock SS estimated selectivity model (top) and hybrid selectivity model (bottom). ....	361
Figure 129.	Observed and estimated catches for the North_Recreational fleet for the northern stock SS estimated selectivity model (top) and hybrid selectivity model (bottom). ....	362
Figure 130.	Observed and estimated discards (in 1000's of fish) for the commercial gill net beach seine fleet for the northern stock SS estimated selectivity model (top) and hybrid selectivity model (bottom).....	363

Figure 131.	Observed and estimated discards (in 1000's of fish) for the recreational fleet for the northern stock SS estimated selectivity model (top) and hybrid selectivity model (bottom). .....	364
Figure 132.	Observed and estimated index values for the NC_BagSeine survey for the northern stock SS estimated selectivity model (top) and hybrid selectivity model (bottom). .....	365
Figure 133.	Observed and estimated index values for the NC_GillNet survey for the northern stock SS estimated selectivity model (top) and hybrid selectivity model (bottom). .....	366
Figure 134.	Observed and estimated index values for the NC_Longline survey for the northern stock SS estimated selectivity model (top) and hybrid selectivity model (bottom). .....	367
Figure 135.	Length compositions, aggregated across time by fleet/survey for the northern stock SS estimated selectivity model (left) and hybrid selectivity model (right).....	368
Figure 136.	Annual length compositions for the North_Commercial_GNBS discards for the northern stock SS estimated selectivity model.....	369
Figure 137.	Annual length compositions for the North_Commercial_GNBS harvest for the northern stock SS estimated selectivity model.....	370
Figure 138.	Annual length compositions for the North_Commercial_Other harvest for the northern stock SS estimated selectivity model.....	371
Figure 139.	Annual length compositions for the North_Recreational discards for the northern stock SS estimated selectivity model.....	372
Figure 140.	Annual length compositions for the North_Recreational harvest for the northern stock SS estimated selectivity model.....	373
Figure 141.	Mean age from the conditional age data for the North_Commercial_GNBS fleet for the northern stock SS estimated selectivity model (top) and hybrid selectivity model (bottom). .....	374
Figure 142.	Mean age from the conditional age data for the North_Commercial_Other fleet for the northern stock SS estimated selectivity model (top) and hybrid selectivity model (bottom). .....	375
Figure 143.	Mean age from the conditional age data for the North_Recreational fleet for the northern stock SS estimated selectivity model (top) and hybrid selectivity model (bottom). .....	376
Figure 144.	Mean age from the conditional age data for the NC_GillNet survey for the northern stock SS estimated selectivity model (top) and hybrid selectivity model (bottom). .....	377
Figure 145.	Mean age from the conditional age data for the NC_Longline survey for the northern stock SS estimated selectivity model (top) and hybrid selectivity model (bottom). .....	378



Figure 146.	Estimated length based selectivities for the northern stock SS estimated selectivity model (top) and hybrid selectivity model (bottom). The North_Commercial_GNBS and North_Recreational selectivities are fixed in the hybrid selectivity model. ....	379
Figure 147.	Estimated age based selectivity for the NC_Longline survey with derived age based selectivities for the other fleets for the northern stock SS estimated selectivity model (top) and hybrid selectivity model (bottom).....	380
Figure 148.	Retention estimates, by regulatory period, for the North_Commercial_GNBS fleet for the northern stock SS estimated selectivity model (top) and hybrid selectivity model (bottom).....	381
Figure 149.	Retention estimates, by regulatory period, for the North_Recreational fleet for the northern stock SS estimated selectivity model (top) and hybrid selectivity model (bottom). ....	382
Figure 150.	Recruitment deviations, with 95% confidence intervals from asymptotic standard errors, for the northern stock SS estimated selectivity model (top) and hybrid selectivity model (bottom). ....	383
Figure 151.	Estimated recruitment (in 1000s) for the northern stock SS estimated selectivity model (top) and hybrid selectivity model (bottom). Error bars are 95% confidence intervals based on asymptotic standard errors. ....	384
Figure 152.	Estimated population (in 1000s of fish) for the northern stock SS estimated selectivity model (top) and hybrid selectivity model (bottom).....	385
Figure 153.	Estimated female SSB (metric tons) for the northern stock SS estimated selectivity model (top) and hybrid selectivity model (bottom).....	386
Figure 154.	Total age-2 fishing mortality (F) for the northern stock SS estimated selectivity model (top) and hybrid selectivity model (bottom). Error bars are 95% confidence intervals based on asymptotic standard errors. ....	387
Figure 155.	SPR timeseries for the northern stock SS estimated selectivity model (top) and hybrid selectivity model (bottom). Horizontal line is the SPR target (0.30). ....	388
Figure 156.	Spawning potential ratio estimates for the northern stock from the previous benchmark stock assessment using a custom statistical catch-at-age model (ASMFC 2017; orange) and the current benchmark assessment SS estimated selectivity model (black). Estimates from the previous assessment are for calendar years while estimates in the current assessment are for fishing years.....	389
Figure 157.	F and SPR timeseries for the northern stock SS hybrid and estimated selectivity models, each scaled to their means.....	390
Figure 158.	Observed and estimated catches for the SC_Recreational (top), GA_Recreational (middle), and FL_Recreational (bottom) fleets for the southern stock SS base model. ....	391

Figure 159.	Observed and estimated discards (in 1000's of fish) for the southern stock SS base model.....	392
Figure 160.	Observed and estimated index values for the FL_21.3_HaulSeine (top), SC_Rotenone (middle), and GA_GillNet (bottom) age-0 recruitment surveys for the southern stock SS base model. ....	393
Figure 161.	Observed and estimated index values for the SC_StopNet (top), SC_Trammel (middle), and FL_183_HaulSeine (bottom) sub-adult surveys for the southern stock SS base model. ....	394
Figure 162.	Observed and estimated index values for the adult longline survey for the southern stock SS base model. ....	395
Figure 163.	Length compositions, aggregated across time by fleet/survey for the southern stock SS base model. ....	396
Figure 164.	Annual length compositions for the SC_Recreational fleet retained catch for the southern stock SS base model. ....	397
Figure 165.	Annual length compositions for the GA_Recreational fleet retained catch for the southern stock SS base model. ....	398
Figure 166.	Annual length compositions for the GA_Recreational fleet discards for the southern stock SS base model. ....	399
Figure 167.	Annual length compositions for the FL_Recreational fleet retained catch for the southern stock SS base model. ....	400
Figure 168.	Annual length compositions for the FL_Recreational fleet discards for the southern stock SS base model. ....	401
Figure 169.	Annual length compositions for the SC_StopNet survey for the southern stock SS base model. ....	402
Figure 170.	Annual length compositions for the SC_Trammel survey for the southern stock SS base model. ....	403
Figure 171.	Annual length compositions for the FL_183_HaulSeine survey for the southern stock SS base model. ....	404
Figure 172.	Age compositions, aggregated across time by survey for the southern stock SS base model.....	405
Figure 173.	Annual age compositions for the SC_StopNet (left), SC_Trammel (middle), and FL_183_HaulSeine (right) surveys for the southern stock SS base model. ....	406
Figure 174.	Mean age from the conditional age data for the SC_Recreational (top) and GA_Recreational (bottom) fleets for the southern stock SS base model.....	407
Figure 175.	Mean age from the conditional age data for the FL_Recreational fleet (top) and SC_Longline_contemporary survey (bottom) for the southern stock SS base model. ....	408
Figure 176.	Length based selectivities for the southern stock SS base model. The SC_Longline_contemporary survey selectivity is fixed. ....	409

Figure 177.	Retention estimates, by regulatory period, for the SC_Recreational (top), GA_Recreational (middle), and FL_Recreational (bottom) fleets for the southern stock SS base model. ....	410
Figure 178.	Age based selectivities estimated for the SC_StopNet (top), SC_Trammel (middle), and FL_183_HaulSeine (bottom) surveys for the southern stock SS base model.....	411
Figure 179.	Recruitment deviations, with 95% confidence intervals from asymptotic standard errors, for the southern stock SS base model.....	412
Figure 180.	Estimated recruitment (in 1000s) for the southern stock SS base model. Error bars are 95% confidence intervals based on asymptotic standard errors.....	412
Figure 181.	Estimated population abundance (in 1000s of fish) for the southern stock SS base model.....	413
Figure 182.	Estimated female SSB (metric tons) for the southern stock SS base model. Error bars are 95% confidence intervals based on asymptotic standard errors.....	413
Figure 183.	Estimated female SSB relative to the estimated SSB <sub>30%</sub> threshold for the southern stock SS base model. Error bars are 95% confidence intervals based on asymptotic standard errors.....	414
Figure 184.	Estimated fleet-specific fishing mortality (F) for age-2 fish for the southern stock SS base model. ....	414
Figure 185.	Total age-2 fishing mortality (F) for the southern stock SS base model. Error bars are 95% confidence intervals based on asymptotic standard errors. ....	415
Figure 186.	SPR timeseries for the southern stock SS base model. Horizontal line is the SPR target (0.30).....	415
Figure 187.	Likelihood profile plot for unfished recruitment (R0) parameter (on the log scale) for the southern stock SS model.....	416
Figure 188.	Spawning stock biomass and relative spawning stock biomass estimates from retrospective analysis of southern stock SS model. Black dashed lines are 95% confidence intervals based on asymptotic standard errors for base model estimates.....	417
Figure 189.	Spawning potential ratio and age-2 fishing mortality estimates from retrospective analysis of southern stock SS model. Black dashed lines are 95% confidence intervals based on asymptotic standard errors for base model estimates.....	418
Figure 190.	Spawning potential ratio estimates for the southern red drum stock from the previous benchmark stock assessment using a custom statistical catch-at-age model (ASMFC 2017; orange) and the current benchmark assessment SS base model (black). Dashed lines are 95% confidence intervals based on asymptotic standard errors. Estimates from the	

	previous assessment are for calendar years while estimates in the current assessment are for fishing years.....	419
Figure 191.	Observed and estimated index values for the GA_GillNet (left), SC_Trammel (middle), and FL_183_HaulSeine (right) surveys from the retrospective analysis for the southern stock SS model. ....	420
Figure 192.	Age-2 fishing mortality and spawning potential ratio estimates from sensitivity analysis of southern stock SS model. Black dashed lines are 95% confidence intervals based on asymptotic standard errors for base model estimates. The dotted black horizontal line is the SPR threshold. ....	421
Figure 193.	Relative spawning stock biomass and spawning stock biomass estimates from sensitivity analysis of southern stock SS model. Black dashed lines are 95% confidence intervals based on asymptotic standard errors for base model estimates. The dotted black horizontal line is the relative biomass threshold. ....	422
Figure 194.	Graphical representation of traffic light analysis fuzzy method regression calculations of proportion of color using relative abundance index data. Intersection of red and yellow lines occurs at the lower 95% confidence interval and the intersection of yellow and green lines occurs at the upper 95% confidence interval. Figure adapted from ASMFC (2020). ....	423
Figure 195.	Annual TLA results for each selected characteristic in the northern stock. Threshold values are represented by the solid horizontal line. The color at the threshold is the color determination for that year.....	424
Figure 196.	Annual TLA results for each selected characteristic in the southern stock. Threshold values are represented by the solid horizontal line. The color at the threshold is the color determination for that year.....	425
Figure 197.	Normalized catch:index ratio for the northern stock using MRIP data recreational harvest of red drum in North Carolina and states further north + North Carolina commercial harvest and the NCDMF gill net index.....	426
Figure 198.	Time series of observed (solid line) and recommended (dashed line) northern stock catch based on Skate analysis using MRIP data on North Carolina and states further north recreational harvest + North Carolina commercial harvest and the NCDMF gill net index.....	426
Figure 199.	Proportional change in catch ( <b>Catch</b> $\Delta$ ) relative to previous fishing year as estimated for the northern stock using the Skate method. No change is denoted by the dashed line at 0, with a reduction in catch (relative to the previous year) needed when less than 0 and vice versa when above. ....	427
Figure 200.	Normalized catch:index ratio for South Carolina (black line) and Florida (red line) and normalized relative F (black dashed line). South Carolina data used MRIP data on South Carolina recreational harvest and the SCDNR ages-2 and -3 trammel net index. Florida data used MRIP data on Florida recreational harvest and the FL FWRI 183 m haul seine survey. ....	428

Figure 201. Time series of observed (solid line) and recommended (dashed line) South Carolina catch based on Skate analysis using MRIP data on South Carolina recreational harvest and the SCDNR ages-2 and -3 trammel net index. .... 428

Figure 202. Proportional change in catch (**Catch**  $\Delta$ ) relative to previous fishing year as estimated for South Carolina (black line) and Florida (red line) using the Skate method. No change is denoted by the dashed line at 0, with a reduction in catch (relative to the previous year) needed when less than 0 and vice versa when above..... 429

Figure 203. Time series of observed (solid line) and recommended (dashed line) Florida catch based on Skate analysis using MRIP data on Florida recreational harvest and the FL FWRI 183 m haul seine survey..... 429

Figure 204. Comparison of scaled mortality estimates/metrics from analyses for the southern red drum stock. .... 430

## TERMS OF REFERENCE

For the 2024 ASMFC Red Drum Benchmark Stock Assessment  
Board Approved February 2023

### *Terms of Reference for the Red Drum Assessment*

1. Evaluate Simulation Assessment Peer Review Panel recommendations for the simulation-based analyses used to guide assessment approaches in this benchmark assessment.

As part of a road map to improve red drum stock assessments, the Red Drum Stock Assessment Subcommittee (SAS) conducted a simulation-based stock assessment (ASMFC 2022) prior to this current benchmark assessment. The goal was to inform selection and application of assessment approaches during this assessment. The simulation assessment was reviewed by a panel of external peer reviewers who included recommendations with their findings on the assessment. A summary of the simulation assessment and peer review is provided in Section 1.3.2 and additional details are provided in ASMFC 2022.

The SAS considered recommendations by the simulation assessment reviewers at the beginning of this benchmark assessment and prioritized two they felt were critical for using the simulation work to inform this assessment. These included (1) determining if the Stock Synthesis (SS) assessment model for the southern red drum stock could produce unbiased estimates while using data without observation error from a simulation operating model and (2) repeating a grid search used to determine reference points for the Traffic Light Analysis (TLA) with only data from the time series anticipated in this benchmark stock assessment.

Work was done within this assessment to address the SS and TLA recommendations and is discussed in Sections 6.2.1 and 6.3, respectively.

2. Provide descriptions of each fishery-dependent and fishery-independent data source.
  - a. Describe calculation and potential standardization of abundance indices.
  - b. Discuss trends and associated estimates of uncertainty (e.g., standard errors).
  - c. Justify inclusion or elimination of available data sources.

Fishery-dependent data sets are described in Section 4. Data sets generated for assessment approaches include fishery removals (landed and discarded dead catch from commercial and recreational fisheries), removals size compositions, and conditional age-at-length. Volunteer angler-based tagging programs and phone applications were used to supplement discard size composition data.

Fishery-independent monitoring surveys conducted by state agencies are described in Section 5. Data sets generated for assessment approaches include indices of abundance, size compositions, age compositions, and conditional age-at-length. Standardized indices of

abundance were generated with model-based approaches (e.g., generalized linear models, GLMs).

Data sets considered in the assessment, but not used for generating inputs to the assessment approaches are described in Appendix A. A notable data change during this assessment and covered in the appendix was the decision to exclude recreational CPUE data sets as measures of abundance due to signs of hyperstability.

3. Develop model(s) used to estimate population parameters (e.g.,  $F$ , abundance) and reference points, and analyze model performance.
  - a. Describe stability of model (e.g., ability to find a stable solution, invert Hessian).
  - b. Justify choice of CVs, effective sample sizes, or likelihood weighting schemes.
  - c. Perform sensitivity analyses for starting parameter values, priors, etc. and conduct other model diagnostics as necessary.
  - d. Clearly and thoroughly explain model strengths and limitations.
  - e. Briefly describe history of model usage, its theory and framework, and document associated peer-reviewed literature.
  - f. If modeling approaches differ from those recommended during the Simulation Assessment, discuss divergence from these recommendations.

Several analyses were developed through the course of this assessment. The primary analyses at the beginning of the assessment were the SS models and TLAs recommended during the simulation assessment. Additionally, a Cormack-Jolly-Seber (CJS) tagging model was developed with South Carolina tagging data. This model was not evaluated during the simulation assessment, but was applied here as a complementary analysis providing mortality trends and to better utilize tag-recapture data available for the assessment, a recommendation of past SASs and review panels. Later in the assessment process as signs of instability persisted in some of the SS models, a data-limited method, Skate, was developed as a backup method in the case that stable SS models could not be developed to provide catch advice. This method also was not evaluated during the simulation assessment, but has been evaluated in a simulation framework for interim use when population dynamics models encounter issues with performance (NEFSC 2020). Development of these methods are described in Sections 6.1 (CJS model), 6.2 (SS models), 6.3 (TLA), and 6.4 (Skate method).

One notable change in modeling structures during this assessment was transition from a year defined according to calendar year (January-December) to a fishing year from September-August. This change was made to better align the data sets and modeled population dynamics to the red drum life cycle (i.e., fall spawning and an assumed biological birthdate of September 1). One drawback was that data originally provided through the 2022 calendar year were not complete for the 2022 fishing year (i.e., no January-August 2023 data) and, therefore, the 2021 fishing year was used as the terminal year in the assessment. This year definition change will be anticipated in future assessments.

SS models for the northern stock showed concerning results in stability diagnostics and were not recommended for stock status determination. However, trend information across analyses in recent years agreed and the SS models are presented for this trend information. The TLA is the recommended approach for stock status determination of the northern stock. The SS model is recommended for stock status determination for the southern stock. Additional analyses for the southern stock are presented as complementary analyses.

4. Discuss the effects of data strengths and weaknesses (e.g., temporal and spatial scale, gear selectivities, aging accuracy, sample size) on model inputs and outputs.

Red drum stock assessments have demonstrated a history of challenges due to the unique combination of life history and regulations that have contributed to notable data limitations (Section 1.3). Key among these are limitations of data on adult fish protected by existing slot limit regulations and high proportions of fishery removals from dead discards caused by slot and bag limit regulations with little data to describe the size compositions of these removals. Limitations of data on adult fish have historically led to “cryptic” adult biomass that is difficult or not possible to estimate. Contemporary adult longline surveys provided six years of data to the last benchmark assessment, but have continued to grow and mature now providing more than double the time series length of the last assessment. There were challenges with modeling these surveys in the current assessment due to some apparent data conflicts, but these surveys are becoming data strengths that provide validation of adult biomass. There are no robust mechanisms to directly sample discard size compositions in recreational fisheries. Various proxy data sources were explored to address this limitation, particularly volunteer angler-based tagging programs (Section 4.2.1.2.2). Proxy data sources provide some limited information, but these data remain a primary limitation for assessments. This limitation leads to uncertainty in partitioning fishing mortality across the population size structure in the assessment models and had to be addressed by fixing some selectivity parameters.

A new development in this current assessment was contrast in fishery-independent indices of abundance for the southern stock, a data strength that provides information on abundance scale and productivity of the stock. Unfortunately, this contrast manifests as declines in recent years. There is still limited contrast in index data for the northern stock. Additionally, there is lack of abundance information north of North Carolina which contributes to a growing uncertainty in the assessment as fishery removals in these areas continue to increase.

Red drum fisheries are primarily recreational and, therefore, assessments are highly dependent on the recreational catch estimates provided by the Marine Recreational Information Program (MRIP). Sensitivity analysis of the assessment models showed that, although scale of estimates is sensitive to multiple uncertainties explored in these catch estimates, trend and stock status estimates are not.

A final notable highlight on data inputs is the time series used in assessments. Data are limited in the 1980s (and before) when red drum fisheries grew and led to implementation of restrictive regulations to curb expected high fishing mortality. There are no fishery-independent indices of abundance in the early and mid-1980s and very few in the late 1980s. Composition



data are sparse and do not start for commercial fisheries until the late 1980s. Catch data also show higher uncertainty (higher proportional standard errors, PSEs) in the 1980s than in later years. However, catch data do show contrast in the early 1980s that matches the perception of higher fishing mortality during these years. One advantage of the SS modeling framework used in the assessment is its ability to handle varying data quantities throughout the modeled time series. In this assessment, the start year was extended back to 1981 from 1989 used in the past benchmark assessment to take advantage of the contrast in early catch data. Sensitivity analysis showed impact from these early data indicative of information the model would miss with a later start year (e.g., 1989).

These data effects on the various assessment approaches are discussed throughout Section 6.

5. State assumptions made for all models and explain the likely effects of assumption violations on synthesis of input data and model outputs. Examples of assumptions may include (but are not limited to):
  - a. Choice of stock-recruitment function.
  - b. Calculation of M. Choice to use (or estimate) constant or time-varying M and catchability.
  - c. Choice of reference points.
  - d. Choice of a plus group.
  - e. Constant ecosystem (abiotic and trophic) conditions.

Parameterizations and assumptions for each assessment approach are described in Section 6. There were a number of fixed inputs to the assessment models that were evaluated with sensitivity analysis to determine their impact on model estimates and stock status. Assessment approaches recommended for stock status determination for each stock (TLA for the northern stock and SS for the southern stock) were generally insensitive to the changes explored in sensitivity analysis.

6. Characterize uncertainty of model estimates and reference points.

Uncertainty was characterized with a combination of techniques including the delta method to generate asymptotic standard errors for model estimates and reference points (CJS model and SS models), retrospective analysis (see below; SS models), and sensitivity analyses (SS models, TLA, and Skate method). These characterizations are covered in Sections 6.1 (CJS model), 6.2 (SS models), 6.3 (TLA), and 6.4 (Skate method).

7. Perform retrospective analyses, assess magnitude and direction of retrospective patterns detected, and discuss implications of any observed retrospective pattern for uncertainty in population parameters (e.g., F, abundance), reference points, and/or management measures.

Retrospective analysis was applied to the southern stock SS model. Instability of the northern stock SS model precluded utility of a traditional retrospective analysis.

The southern stock SS model had a tendency to underestimate SSB and overestimate fishing mortality, indicating the less concerning retrospective bias directionality from a precautionary perspective. Magnitude of the retrospective bias was driven by the three-year peel (terminal year of 2019). The application of adjustments to estimates to account for the retrospective bias did not change the stock status point estimates in the assessment terminal year. For these reasons, the SAS decided not to apply adjustment to final estimates. Details of the analysis are provided in Section 6.2.2.

8. Recommend stock status as related to reference points (if available). For example:
  - a. Is the stock below the biomass threshold?
  - b. Is F above the threshold?

The northern red drum stock was not overfished and was not experiencing overfishing. The TLA fishery performance metric was not red in any of the three terminal years (2019-2021), indicating overfishing was not occurring. The Adult Abundance metric was not red in any of the three terminal years, indicating the stock was not overfished.

The southern red drum stock was overfished and experiencing overfishing in the terminal year of the assessment. The three-year average spawning potential ratio (SPR) in 2021 was 0.207 which is below the threshold (0.30), indicating overfishing. The three-year average relative SSB in 2021 was 0.881 which is below the threshold (1.0), indicating an overfished stock.

Stock status determinations are discussed in Section 7.

9. Other potential scientific issues:
  - a. Compare trends in population parameters and reference points with current and proposed modeling approaches. If outcomes differ, discuss potential causes of observed discrepancies.
  - b. Compare reference points derived in this assessment with what is known about the general life history of the exploited stock. Explain any inconsistencies.

SPR reference points recommended include a target (SPR = 0.30 or 30%) and a threshold (SPR = 0.40 or 40%). These reference points are consistent with reference points recommended in past assessments and were reviewed and deemed appropriate by the Red Drum Technical Committee for red drum life history following the previous benchmark stock assessment (ASMFC 2017b). SSB reference points are new reference points in this assessment, as previous assessment models were believed to be too coarse (age-7 plus group) and data too sparse (short adult longline survey time series) to provide accurate estimates of SSB. The SS models used in this assessment expanded the modeled age structure out to maximum observed age and the adult longline survey time series have grown. The assessment approaches used in this assessment were also shown to perform well estimating SSB status during the simulation assessment preceding this benchmark stock assessment (ASMFC 2022).

A historical retrospective analysis compared estimates from the previous benchmark stock assessment and this current assessment (Section 6.2.2). The analysis for the northern stock

showed divergent SPRs between the previous statistical catch-at-age model and the new SS model in the beginning of the time series with the scale of the SPR estimates from the two models converging around 2010. This early divergence highlights uncertainty with scale and initial condition estimates for the northern stock, contributing to the decision not to use the northern SS model for stock status determination in this assessment. While the scales are different early in the time series, both models show a generally increasing SPR in the early 1990s which begins to decrease in the mid- to late-2000s. These trends are corroborated by increasing trends in fishing mortality estimated with the other assessment approaches applied to the northern stock in this assessment.

The historical retrospective analysis for the southern stock shows very similar SPR estimates in the first four years that overlap between assessments (1989-1992). The SS model in the current assessment then estimates more of a decline for the remainder of the overlapping time series than the statistical catch-at-age model used in the previous assessment. Both assessments estimated a decline in the terminal year of the previous assessment (2013), but the SS model estimates a greater magnitude in this decline. The wide confidence intervals from the last assessment generally include the point estimates and their confidence intervals from the current assessment and demonstrate one of the primary deficiencies of the previous assessment. The decreasing trend in SPR estimated with the SS model is corroborated by increasing trends in fishing mortality estimated with the other assessment approaches applied to the southern stock in this assessment.

10. If a minority report has been filed, explain majority reasoning against adopting approach suggested in that report. The minority report should explain reasoning against adopting approach suggested by the majority.

No minority report was filed.

11. Develop detailed short and long-term prioritized lists of recommendations for future research, data collection, and assessment methodology.

The SAS prioritized eleven short-term and seven long-term research recommendations (Section 8). Short-term recommendations are those that would take less time (1-5 years) to produce results to support future assessments. Long-term recommendations are those that will take a longer period of time (5-10+ years) to produce results to support future assessments. Work on all high priority recommendations should commence immediately.

12. Recommend timing of next benchmark assessment and intermediate updates, if necessary, relative to biology and current management of red drum.

The SAS recommends conducting the next benchmark assessment in five years to allow for six additional fishing years (through 2027) of data past the terminal year in this assessment. The SAS does not recommend allowing a greater period between assessments due to the condition of the stocks in this assessment.

Before the next benchmark assessment, the SAS recommends updating the TLAs every two years, with the first update using the 2023 fishing year as the terminal year and the second update using the 2025 fishing year as the terminal year.

## **1 INTRODUCTION**

### **1.1 Management Unit Definition**

The ASMFC manages red drum under the authority of the Atlantic Coastal Fisheries Cooperative Management Act (ACFCMA), with the management unit defined as the red drum resource throughout the range of the species within U.S. Atlantic coast waters of the estuaries eastward to the offshore boundaries of the Exclusive Economic Zone (EEZ) from Florida through New Jersey. The selection of this management unit is based on the biological distribution of the species along the Atlantic coast and historical harvest patterns, which have identified fisheries for red drum. The management unit is divided into a southern stock and a northern stock. The southern stock includes the waters of the Atlantic coast of Florida north to the North Carolina/South Carolina border. The northern stock extends from the North Carolina/South Carolina border north through New Jersey.

### **1.2 Regulatory and Management History**

The ASMFC adopted a Fishery Management Plan (FMP) for red drum in October 1984 (ASMFC 1984) with an original management unit of the states from Florida to Maryland. The plan was designed to address recreational-commercial conflicts and lack of data needed to define optimum yield (OY). At this time, the ASMFC managed red drum in tandem with the South Atlantic Fishery Management Council (Council). The Council managed red drum in federal waters whereas the ASMFC managed state waters. The plan adopted the following objectives:

- 1) Attain, over time, optimum yield.
- 2) Maintain a spawning stock sufficient to minimize the possibility of recruitment failure.
- 3) Promote the cooperative interstate collection of economic, social, and biological data required to effectively monitor and assess management efforts relative to the overall goal.
- 4) Promote cooperative interstate research that improves understanding of the biology and fisheries of red drum.
- 5) Promote harmonious use of the resource among various components of the fishery through the coordination of management efforts among the various political entities having jurisdiction over the red drum resource.
- 6) Promote determination and adoption of the highest possible standards of environmental quality and habitat protection necessary for the natural production of red drum.

To move towards optimum yield, the original FMP recommended states institute a 14 inch total length (TL) minimum length limit with comparable mesh size regulations instituted to minimize harvest of small fish in directed fisheries. Further, it recommended states bar possession of

greater than 2 fish 32-inch TL and greater per day and a prohibition of purse seining for red drum.

In November 1990, the Council adopted a similar FMP for red drum that defined overfishing and OY consistent with the Magnuson-Stevens Fishery Conservation and Management Act of 1976. Adoption of this plan prohibited harvest of red drum in the EEZ, a moratorium which remains in effect today. Recognizing all harvest would take place in state waters, the Council FMP recommended states implement measures to constrain harvest. Further, it defined OY as the harvest amount that could be taken while maintaining spawning stock biomass per recruit (SSBR) at or above 30% of the level which would result if fishing mortality was zero (i.e., spawning potential ratio, or SPR, of 30%) and recommended states implement measures to achieve at least 30% escapement of sub-adult red drum to the offshore adult spawning stock.

Following this request, ASMFC initiated Amendment 1 to the ASMFC red drum FMP, which went into effect in October 1991. This Amendment adopted the SAFMC FMP for red drum and recommended complimentary measures for states (New Jersey through Florida) to achieve OY.

Substantial reductions in fishing mortality were necessary to achieve the escapement rate; however, the lack of data on the status of adult red drum along the Atlantic coast led to the adoption of a phase-in approach with an initial 10% SPR goal. In 1991, states implemented or maintained harvest controls necessary to attain the goal. Per ASMFC Amendment 1, ASMFC recommended states adopt either an 18–27-inch TL slot limit and 5 fish person<sup>-1</sup> bag limit (1 fish >27 inches TL) or a 14–27-inch TL slot limit and 5 fish person<sup>-1</sup> bag limit.

Amendment 1 and Amendment 2 to the Council's FMP both went into effect in October 1998. Amendment 1 updated MSY to 30% SPR, OY to 40% SPR, an overfishing status at less than 30% SPR, and an interim overfishing threshold as 10% SPR (ASMFC 2002). Amendment 2 identified, described and recommended measures to protect Essential Fish Habitat (EFH) and EFH Habitat Areas of Particular Concern for red drum as part of the Council's comprehensive habitat amendment (SAFMC 1998b).

In 1999, the Council recommended management authority for red drum be transferred to the states under the ACFCMA. This was recommended, in part, due to the inability to accurately determine an overfished status, and therefore stock rebuilding targets and schedules, as required under the revised Sustainable Fisheries Act of 1996. The transfer necessitated the development of an amendment to the ASMFC FMP to include the provisions of the ACFCMA.

The subsequent amendment, Amendment 2 to the ASMFC FMP, moved management authority of red drum from the Council to the states in June 2002 (ASMFC 2002) and serves as the current management plan. The final rule that repealed the Council's FMP and transferred management authority of Atlantic red drum in the EEZ from the Council to the ASMFC became effective November 5, 2008. The Amendment required states to implement recreational creel and size limits to achieve the fishing mortality target, including a maximum size limit of 27 TL, and maintain existing or more conservative commercial regulations. A harvest moratorium and Presidential Executive Order, enacted in 2007, prevents any harvest or sale of red drum from

federal waters. The goal of Amendment 2 is to achieve and maintain the OY for the Atlantic coast red drum fishery as the amount of harvest that can be taken by U.S. fishermen while maintaining the SPR at or above 40%. There are four plan objectives:

- 1) Achieve and maintain an escapement rate sufficient to prevent recruitment failure and achieve an SPR at or above 40%.
- 2) Provide a flexible management system to address incompatibility and inconsistency among state and federal regulations which minimizes regulatory delay while retaining substantial ASMFC, Council, and public input into management decisions; and which can adapt to changes in resource abundance, new scientific information, and changes in fishing patterns among user groups or by area.
- 3) Promote cooperative collection of biological, economic, and sociological data required to effectively monitor and assess the status of the red drum resource and evaluate management efforts.
- 4) Restore the age and size structure of the Atlantic coast red drum population.

The SPR of 40% is considered a target; an SPR below 30% (threshold level) results in an overfishing determination for red drum. All states were in compliance by January 1, 2003.

The Board approved Addendum I to Amendment 2 in August 2013. The Addendum sought to increase the knowledge base and aid in the protection of important red drum habitat by updating Amendment 2's habitat section to include more up to date information on red drum spawning habitat and habitat by life stage (egg, larval, juvenile, sub-adult, and adult). The addendum also identified and described the distribution of key habitats of concern, including threats, habitat bottlenecks, and ecosystem considerations.

Red drum state-specific regulations through time are provided in Table 1 (northern stock) and Table 2 (southern stock).

### **1.3 Assessment History**

There have been eight previous regional benchmark assessments for red drum inhabiting Atlantic coast waters of the U.S. (Vaughan and Helser 1990; Vaughan 1992; Vaughan 1993; Vaughan 1996; Vaughan and Carmichael 2000; SEDAR 2009a; SEDAR 2015a; ASMFC 2017b). The most recent regional assessment project for red drum was an assessment of simulated red drum stocks to support model selection for this current benchmark assessment (ASMFC 2022). There have also been state-specific assessments conducted in Florida, South Carolina, and North Carolina.

#### **1.3.1 Regional Stock Assessments**

Early regional assessments (through Vaughan 1993) analyzed red drum as one coastwide stock and used catch curves and virtual population analyses (VPAs) to analyze the catch age

composition data of only young red drum (ages 0-5 – see note on age convention in next paragraph). These early assessments were designed to remove the effect of emigration on the apparent decline (mortality) in catches of red drum as they moved from heavily fished inshore sub-adult habitats to more lightly fished offshore adult habitats. For the most part, the condition of the stock was inferred from the calculated level of escapement through age-5, though they also calculated SPR (reported in these assessments as maximum spawning potential or MSP) as a management benchmark despite little information on adult catches. These assessments estimated high mortality and low escapement and SPR throughout the 1980s and into the early 1990s.

Beginning with Vaughan (1996), the assessment separated the coastwide population into the two stock definitions currently used in assessments, a northern stock from the SC/NC border north and a southern stock from the SC/NC boarder through SE FL along the Atlantic coast. Major concerns beginning in this assessment were increasing numbers of live releases (and resultant dead discards) in the highly regulated recreational fisheries and the effects of minimum/maximum size restrictions complicating estimation of selectivity. The assessment introduced the use of VPA with indices of abundance included as inputs (tuned VPA). Given the difficulties estimating the decline in vulnerability associated with the sub-adult transition to offshore waters, the assessment used a series of predefined linkages between age-specific selectivities to constrain the analyses. This assessment estimated high mortality and low SPR (<15%) continuing into the mid-1990s.

The next assessment by Vaughan and Carmichael (2000) used two VPAs (SVPA and FADAPT) and a spreadsheet-implemented, forward projecting statistical catch-at-age analysis. It should be noted there was a change in the definition of the age designation during this assessment that was maintained in all subsequent assessments until the current assessment (see Section 1.3.4). The first calendar-year age in early assessments was designated age-0 (January-December for biologically 4-16 month old fish). This was redefined as age-1 (given the convention of incrementing age on January 1) in the 2000 assessment. The assessment investigated uncertainty in the age structure of live-released mortalities was investigated by manipulating the lengths of red drum measured from angler creels. A range of release mortalities and selectivity linkage constraints were utilized in all analyses. The FADAPT VPA was selected as the preferred analysis for estimates of fishing mortality and SPR. In the northern stock, estimates of SPR increased from 1.3% for the period 1987-1991 to approximately 18% for the period 1992-1998. For the southern stock, estimates of SPR increased from 0.5% for the period 1988-1991 to approximately 15% for the period 1992-1998. These estimates indicated overfishing was occurring in both stocks.

The first SouthEast Data, Assessment, and Review (SEDAR) process for red drum, SEDAR 18, concluded in 2009 with data through 2007 (SEDAR 2009a). This assessment transitioned to new forward projecting statistical catch-at-age (SCA) models developed in AD Model Builder (ADMB). These SCA models relax assumptions required by the precursor VPA analyses that assume catch age composition data are observed without error and were seen as advancements in models due to some data limitations in constructing the age composition



data. The models included several unique aspects due to data availability and red drum life history, including the constraint of estimating selectivity of ages-4 and 5+ as proportions of age-3 selectivity, grouping all ages older than age-6 into a plus group, and using fishing mortality and selectivity information from an external tagging analysis in the modeling procedures (northern stock only). The models used fishery catch and age compositions, indices of abundance, and life history information (growth, maturity, and natural mortality). Like the VPAs, these models produced fishing mortality estimates that could be used to calculate SPR for comparison to reference points and status determination.

In the northern stock, SPR estimates increased from lows less than 10% in the beginning of the time series to values above the target (40%) by the mid-1990s. SPR was estimated to have varied at these higher levels above the threshold and often above the target for the remainder of the time series. In the southern stock, SPR was estimated to have been at the highest levels in the early 1990s then declined slowly but remained above the threshold and target throughout the rest of the time series. The assessment provided a three-year average SPR over the last three years of the assessment time period (2005-2007) for stock status determinations to address uncertainty with annual estimates. Both stocks were determined not to be experiencing overfishing. Due to data limitations and poor estimates of the adult components of the stocks, the assessment could not make a determination of spawning population status (i.e., overfished vs. not overfished).

This assessment was accepted by a peer review panel (RP), but peer reviewers noted limitations and concerns with the SCA models that should be addressed in future assessments. The northern model was sensitive to inclusion of the external tagging analysis estimates used as inputs in the base model configuration and results were conditional on these inputs. Without these inputs, results were different and indicated conflict between these inputs and the other more traditional data inputs (catch age composition, indices of abundance). Further, the reviewers noted unusually high fishing mortality estimates from the external tagging analysis early in the time series. The RP recommended direct inclusion of the tag-recapture data as model inputs in future assessments as opposed to externally-derived population parameter estimates.

Peer reviewers also expressed concern with uncertainty of model estimates, particularly for the southern stock. Confidence intervals were large and results were sensitive to selectivity estimates, allowing for only general, qualitative statements about stock conditions. Reviewers noted highly uncertain and unrealistically large initial abundance estimate for older fish in the southern and northern models, respectively. These issues were explored during the workshop but remained after not arriving at solutions. Poor fits to catch age composition data resulted in age-specific patterning in residuals and the model time series was shortened during the review to exclude sparse composition data prior to 1989. The assessment team and RP agreed that model structure was a major source of uncertainty in the assessment.

During a second SEDAR process in 2015 (SEDAR 44; SEDAR 2015a), an attempt was made to transition to integrated assessment models developed with the Stock Synthesis (SS) integrated

analysis framework (Methot and Wetzel 2013). This transition was in response to limitations of the SCA models and recommendations by the SEDAR 18 peer RP. SS is an age- and size-structured assessment model in the integrated analysis class of models. It has 1) a population sub-model that simulates growth, maturity, fecundity, recruitment, movement, and mortality processes, 2) an observation sub-model which predicts values for the input data, 3) a statistical sub-model which characterizes goodness of fit and obtains best-fitting parameters and their associated variance, and 4) a forecast sub-model which projects various user-determined management quantities (Methot et al. 2023). SS allows for observed tag-recapture data and both length and age length key data as inputs, reducing data processing external to the model and better propagating uncertainty in model results. SS is also more flexible for modeling time series with varying data availability and the framework was anticipated to better utilize sparse data during the period of high exploitation prior to the 1989 start year in SEDAR 18.

Several challenges were experienced during model development resulting in poor model stability and no preferred model in time for the peer review workshop, so the objective of the workshop changed from evaluating final model results for management advice to evaluating current model configurations and making recommendations to improve these configurations. The assessment team addressed recommendations following the workshop and final model results were reviewed during a subsequent peer review. The SPR estimates were quite different from SEDAR 18, indicating the stocks had been experiencing overfishing throughout the time series. The 2011-2013 three-year average SPR was estimated to be 9.2% in the northern stock and 17% in the southern stock, both below the SPR threshold.

Peer reviewers accepted the assessment but they identified notable concerns, including sensitivity of the northern model stock status determination to treatment of the tag-recapture data. The models were not accepted by the South Atlantic State/Federal Fisheries Management Board (Board; predecessor of the Sciaenids Management Board) due to concerns with the reliability of population parameter estimates. Instead, the Board tasked the Technical Committee (TC) and Stock Assessment Subcommittee (SAS) with several tasks including to evaluate the utility of the SCA models used in SEDAR 18 for updated management advice.

The SAS updated the SCA models in an additional assessment (ASMFC 2017b) with recent data and explored several potential changes to these models, including data changes, but recommended models with minimal structural changes for management advice. The 2011-2013 three-year average SPR was estimated to be 43.8% in the northern stock and 53.5% in the southern stock, both above the SPR threshold and target, indicating that overfishing is not occurring. However, the issues that arose with the models during SEDAR 18 remained and were noted by the peer reviewers of this assessment.

Peer reviewers noted that examination of the assessment results, as well as corroborating information from the fishery-independent (FI) indices, suggested both the northern and southern stocks appeared to be above their management thresholds. However, reviewers concluded there was a high degree of uncertainty associated with these assessments due to the lack of good fishery-dependent and -independent data on the oldest and most fecund age

classes, coupled with sensitivity to data weightings and initial conditions suggesting an overall scaling problem with both regions' assessments. The wide confidence intervals in the south and the unrealistic decline in abundance over the time series in the north suggest fundamental assessment and data issues. Given the life-history and pattern of exploitation, they stated it was unclear how these issues could be easily resolved. They noted further work was needed given the critical dependency of overfishing status determination on the fishing mortality estimates for older fish and the difficulties of estimating fishing mortality when population size is indeterminate; therefore, the assessment gave only a rough measure of stock status.

### **1.3.2 Simulation Assessment**

The uncertainties and modeling challenges for assessing red drum described above led to the Board tasking the ASMFC's Assessment Science Committee (ASC) with providing a road map for future red drum stock assessments following the most recently completed stock assessment (ASMFC 2017b).

In collaboration with the Red Drum SAS, the road map produced by the ASC recommended evaluating three potential frameworks to develop management advice from the next benchmark stock assessment (in no particular order):

1. model-free stock indicators, similar to traffic light analyses used for Atlantic croaker and spot,
2. a population dynamics model tracking the juvenile components of the stocks, and
3. a population dynamics model tracking all life stages of the stocks.

The anticipated advantage of the first framework was being able to provide advice on all life stages with data currently available, with the most notable disadvantage being no quantitative stock status estimates. Rather, this framework would provide stock status as changes in individual data sets or indicators relative to a predefined period in the available data. The anticipated advantage of the second framework was being able to provide estimates of stock status relative to potential productivity from integrated juvenile data (currently available), with the most notable disadvantage being stock status estimates that are not directly influenced by changes in the mature, adult components of the stocks (data currently limited or not available). The anticipated advantage of the third framework was being able to provide estimates of stock status relative to potential productivity from integrated data across life stages, but estimates from this framework were likely to have relatively high levels of uncertainty given data limitations on adult components of the stocks (i.e., lack of age composition data characterizing dead discards). Further, the Board had expressed interest in being able to determine whether or not the stocks can be declared rebuilt or not, necessitating the estimation of the adult component of the stocks and encouraging the exploration of this third framework.

The road map recommended the use of simulation analyses as the basis for evaluating these potential frameworks. Simulation models would be used to simulate red drum stocks, with

known population dynamics, subjected to various fishing mortality scenarios, with the simulated stocks subsequently being sampled for data mimicking available data streams for stock assessment of *in situ* stocks. Data streams would then be applied to the three potential frameworks to evaluate their reliability in characterizing the known stock status of the simulated stocks. The results would be used to infer reliability of the candidate frameworks when applied to the *in situ* red drum stocks and to recommend the preferred framework(s) for providing management advice during subsequent stock assessments of the *in situ* stocks. Simulation testing was also recommended to identify the data deficiencies causing uncertainty in assessment advice to focus improvements in data collection efforts.

The recommended timeline was for a two-stage assessment process over a four-year period, with a first stage devoted to a simulation analysis and a second stage devoted to a traditional benchmark stock assessment of *in situ* stocks (which this report covers). The Board agreed with the recommendations in the roadmap at the ASMFC 2020 Winter Meeting and initiated the development of the simulation assessment. The simulation assessment was completed and peer reviewed in Spring 2022 (ASMFC 2022).

The simulation process used consisted of several steps. The first step was the data simulation process, where observed data from *in situ* monitoring programs were used to construct simulated populations of the northern and southern red drum stocks. The operating models (OMs) were developed with the *ss3sim* R package (Anderson et al. 2014; Johnson et al. 2021), a simulation platform to complement the SS modeling framework. Simulated sampling datasets were then sampled from simulated stocks with the OM and passed to each of the estimation models (EMs) being considered as candidates for future red drum stock assessment models.

The simulation assessment evaluated the performance of three candidate assessment models: a traffic light analysis (TLA) of model-free stock indicators, used previously for Atlantic croaker and spot management advice; the SCA models used for the most recent red drum benchmark stock assessment in 2017; and an SS model using the platform attempted in SEDAR 44 and widely used in stock assessments.

The assessment approaches were evaluated based on their performance estimating population parameters important to management through multiple iterations of each simulation scenario. Assessment model estimates were compared to the known population parameters of the OM to calculate performance metrics, and these performance metrics were compared to those of the other assessment models to evaluate relative performance across assessment models. Evaluation of performance was both qualitative and quantitative.

The first evaluation criterion was the ability of a given model to successfully run an iteration of a scenario and converge on a solution (only applies to SCA and SS EMs). Models may have varying amounts of difficulty running scenarios depending on specification and convergence rates provides information on the stability of the estimation model.

If a model successfully ran an iteration, performance was then evaluated on how each approach estimated stock status/condition and the precision and accuracy of parameters. For

stock status/condition, Type I and Type II error rates were the metrics of interest. Type I error (false positive) was defined as incorrect rejection of a null hypothesis of favorable condition/status (e.g., stock was estimated to be in poor condition when it was really in good condition), while Type II error (false negative) was the incorrect rejection of a null hypothesis of unfavorable condition/status (e.g., stock was estimated to be in good condition when it was really in poor condition). Error rates were quantified by their frequency of occurrence across iterations for a given model and scenario. Relative error was used to assess precision and bias of quantitative population parameter estimates for each model. Relative error was used quantitatively to examine the magnitude and direction of error for individual parameter estimates.

Simulation scenarios to be addressed in the assessment were identified at the beginning of the assessment and grouped into two types: core population dynamics scenarios and data prioritization scenarios. Core population dynamics scenarios were to evaluate candidate assessment approaches for assessing red drum stocks with status quo monitoring under various scenarios that may play out in future red drum stock assessments. The data prioritization scenarios were designed to evaluate improvements in modeling performance with changes to status quo monitoring with a goal of informing research recommendations for future monitoring of red drum stocks.

The simulation results led to a recommendation from the SAS to pursue both the SS and TLA assessment approaches in the upcoming assessment for the northern stock of red drum; further pursuit of the SCA model for the northern stock was not recommended. The SCA had two identified and concerning deficiencies detracting from its use as an assessment model for the northern stock, namely its sensitivity to weighting scheme and reliance on Bachelier et al. (2008) tag-based data inputs.

The SS model performed as well or better than the other northern EMs in terms of accuracy. Additionally, the SS model performed well under the *2023 Term Yr* scenario, which included shortened time series to mimic that anticipated in the upcoming benchmark assessment. This was indicated by a general lack of a decrease in precision of the SS model under the *2023 Term Yr* scenario relative to the *Base* scenario, which included longer time series simulated well beyond the terminal year anticipated in the upcoming benchmark assessment.

Investigation of the TLA suggested there is utility in continuing to develop it as a potential assessment methodology for red drum. For the northern stock, it is comparable to the SS EM in making spawning stock biomass status determinations, and outperforms SS when characterizing recruitment condition. Hence the TLA showed utility as a supplementary, alternative assessment approach for development of SSB status and recruitment condition determinations. Such development was recommended to occur simultaneously with the SS model in the upcoming benchmark assessment. An additional benefit of further TLA model development was its relative ease to update; this suggests a TLA approach could be used during interim periods between formal assessments to update stock status for management advice.

However, use of the TLA for fishing mortality status determinations in the northern stock was cautioned due to its poor performance in terms of error rates.

The simulation results also led to a recommendation from the SAS to pursue all three assessment approaches in the upcoming assessment for the southern stock of red drum given more consistency in performance across approaches. Relative to the southern SCA EM, the southern SS EM estimated with slightly greater precision during the projected period in the immediate future, though the SCA EM estimated with greater accuracy. However, the SS model remains a more flexible assessment platform, which should be a benefit to the assessment of the southern stock of red drum with its unique fishery and life history characteristics that pose challenges to traditional statistical catch-at-age models. The southern stock results indicated the TLA was useful for all metrics, including fishing mortality status, which was deemed an unreliable TLA metric for the northern stock. Further, error rates in stock status, in terms of fishing mortality status and SSB status, were comparable to both the SCA and SS EMs for the southern stock and the TLA continued to outperform the age-structured models in characterizing recruitment condition. Hence the TLA showed utility as a supplementary, alternative assessment approach for development of fishing mortality status, SSB status and recruitment condition determinations in the southern stock. The SCA continued to show sensitivity to changes in weighting schemes, with weighting affecting mostly convergence rates. However, compared to the effect changing weight had on the SCA for the northern stock, the change in weighting had less of an effect on scale estimation and did not affect the trend of estimates for either stock. One caution was indicated by the results for the SCA model that should be considered in the upcoming benchmark assessment. Though precision of the SCA estimates was reasonable and comparable to the other considered EM approaches when evaluated for the full simulated time series, precision drastically decreased under the *2023 Term Yr* scenario. This is similar to the situation noted during the ASMFC 2017 benchmark stock assessment.

Finally, it became apparent during the review of the results that models, specifically for the southern stock, provided accurate trends in  $F$ , SSB, and recruitment. As such, this suggested a potential alternative management approach for red drum could be developed based on trends and levels relative to a reference time period. This is similar to the approach used for the development of stock status recommendations for the ASMFC-managed Atlantic menhaden (ASMFC 2017a). Work would be needed to define an appropriate time period to develop such a set of reference points, including input from the Board.

A final objective of the simulation assessment was to develop scenarios useful for identifying data prioritizations necessary to improve the accuracy and precision of stock status estimates. These scenarios included evaluating the length of the adult longline survey time series, changes in recreational discard composition data availability and quality, and impacts of growth misspecification. Although the results provided some intuitive results to help prioritize future data collections (e.g., improved selectivity estimates with improved discard size composition data), the scenarios produced a number of unintuitive results (e.g., little to no impact to model

results when longline survey data are excluded from the model) that needed further work to fully understand and support future data collection/modeling recommendations.

During the peer review, the RP recommended not pursuing the SCA model for either stock and instead devoting efforts to development of the other two approaches (TLA analysis and SS models). The SAS ultimately agreed with this change as a reasonable path forward in the upcoming benchmark assessment. The RP agreed with the SAS that continued development of the SS models should be prioritized given the SS framework is essentially an SCA approach with more flexibility than the red drum SCA model and the TLA showed utility as a complementary assessment approach that should also be prioritized for application in the upcoming benchmark.

The RP did make a number of recommendations during their review, with two being considered by the SAS as the highest priority for addressing following the simulation assessment. The RP expressed concern over the method for determining the reference points used in the evaluation of TLA performance. The grid search method used information from the entire time series of the simulation, including the projection years. Therefore, the TLA leverages information not available to the other models and would not be available to a TLA based on *in situ* data. The RP recommended repeating the grid search using only the ‘burn in’ and pre-2023 periods to see if the reference points identified were similar to the ones identified in the presented assessment. The reduced time series grid search would be more directly comparable to the other assessment models and would be representative of options available in an *in situ* application of the TLA. Second, during the peer review, the RP requested EMs be fit to data from the OM generated without observation error. While the northern SS EM was able to produce unbiased parameter estimates from these data, the SS EM for the southern stock could not produce unbiased parameter estimates during the review workshop. The RP noted the southern SS EM needed additional work to determine if the model could produce unbiased estimates while using data without observation error from the OM.

Finally, it was noted during the simulation assessment that recommendations should guide workloads and preparation for the upcoming benchmark, though, ultimately, the preferred approach would depend upon fits to the observed data from *in situ* stocks available in the benchmark.

### **1.3.3 State Stock Assessments**

#### **Florida**

The Florida Fish and Wildlife Conservation Commission (FL FWC) has conducted several assessments of red drum, with the most recent assessment utilizing data through 2019 (Addis 2020). This assessment was conducted to assess the status of red drum populations found in four different regions along the Atlantic and Gulf Coast of Florida. The two regions of the Atlantic coast were defined as the southeast region (SE), from Miami-Dade through Volusia counties, and the northeast region (NE), from Flagler through Nassau counties.

SS models were developed, run from 1989 to 2019, accounted for 41 ages (0-40+), and were fit to catch, CPUE indices, length composition, and size-at-age data. Fits to the datasets from a parametric bootstrap analysis were adequate for all regions as most base run estimated parameters and derived quantities were inside the central range of the estimates produced by the bootstrap analysis.

Overall fishing mortality rate estimates for red drum ages 1- remained at low levels since the late 1980s in all four regions, though, recent increases in fishing mortality rates were apparent in the NE from 2010-2019 and the SE from 2015- 2018. Terminal year spawning stock biomass (SSB) was estimated to be 17,163 and 27,940 mt in the NE and SE regions, respectively.

Ratios of  $SSB_{current}/SSB_{SPR35\%}$  and  $F_{current}/F_{SPR35\%}$  from the two assessment regions indicated red drum were neither overfished nor undergoing overfishing in Florida.

Estimates of current escapement rates in the NE region exceeded 40%. Finally, although the SE region of Florida exceeded the escapement rate management target in the terminal year (2019) of the assessment (55%), it did not meet the current escapement rate management target. Escapement rates for 2017-2019 were 61% and 35% in the NE and SE regions, respectively.

### South Carolina

Using data from September 1982 thru August 2016, the South Carolina Department of Natural Resources (SC DNR) conducted a stock assessment to assess the status of the red drum population found along coastal South Carolina (Murphy 2017). Data used included catch, effort, relative abundance, size/age composition, and tag-recapture data sets. The assessment investigated three different assessment frameworks, a SS model excluding tag-recapture data, a SS model including tag-recapture data, and a SCA model as employed during ASMFC 2017b, with each giving broadly similar results.

The assessment suggested the abundance of juvenile and sub-adult red drum along coastal South Carolina increased from low levels in the early- to mid-1980s in response to increasing levels of recruitment in the early 1980s despite high levels of fishing. Abundance of adult red drum continued to remain low or decline until the mid-late 1980s when these abundant groups of sub-adults recruited to the adult population and the abundance of adults began to rise. Fishing mortality declined dramatically after hitting peak values during 1985-1988 and continued declining at a slow rate through the late 1990s. During this time, the red drum population responded with variable but slowly declining recruitment, and an increased abundance of sub-adults and adults. Fishing mortality began to increase steadily after 2000 as the number of discarded red drum (and inevitable discard deaths) increased dramatically. Finally, recruitment declined rapidly after 2008 and abundance of sub-adults and adults followed suit after 2010. SPR increased from low levels in the 1980s to levels exceeding typical biological target levels during the 1990s and early to mid-2000s. Since 2008, SPR levels have fluctuated between about 20-40% before declining in the 2014 and 2015 fishing years to likely be below 20%, indicating the population was experiencing overfishing.



### North Carolina (description modified from Vaughan 2009)

An assessment was conducted by the North Carolina Division of Marine Fisheries (NCDMF; Takade and Paramore 2007) and included data provided by the Virginia Marine Resources Commission (VMRC) to update the earlier assessment by Vaughan and Carmichael (2000) for the northern red drum stock.

The northern red drum stock was assessed using commercial, recreational, and fishery-independent data from 1986 to 2005. Results were broken into three regulatory periods with relatively uniform regulations (early: 1986-1991, mid: 1992-1998, and late: 1999-2005). A major assumption in this assessment was assigning an accurate length distribution to released fish from the recreational fishery. While several assumptions on the length distribution of recreational releases were calculated, the preferred matrix used length frequencies estimated from modeling of NCDMF tag returns. Late period age-3 selectivity was estimated to be 0.48 of fully selected fish (age-2), and was estimated from modeling of NCDMF tag returns. Two models from the Vaughan and Carmichael (2000) assessment were updated: the backward calculating FADAPT VPA and the forward calculating spreadsheet catch-at-age model.

Fishing mortality estimated from FADAPT ranged from 0.50 to 0.49, with escapement ranging from 40.6% to 41.0% and SPR ranging from 40.4% to 40.8%. The spreadsheet catch-at-age model fishing mortality estimates ranged from 0.66 to 0.63, with escapement estimated at 32.8% and SPR estimated at 32.3%. All estimated runs using the TAGGING matrix from both models were above the threshold of 30% SPR and the FADAPT estimates were above the target of 40% SPR. All runs showed improvements in escapement and SPR from the previous regulation period (1992-1998).

This assessment indicated that fishing mortality had decreased and escapement and SPR had increased for the red drum northern stock during the latest management period (1999-2005). The updated model estimates in this assessment were all above 30% SPR and, therefore, indicated overfishing was no longer occurring. It appeared the condition of the northern red drum stock had improved and that the more restrictive management measures implemented had aided in that improvement.

#### **1.3.4 Year Definition for Stock Assessment**

All previous red drum stock assessments have been conducted with a calendar year definition from January 1 through December 31. Age data had been adjusted assuming a January 1 birthdate to keep cohorts together and advancing through the age structure of the assessment time series. During the current stock assessment, the SAS decided to change to a fishing year definition from September 1 of calendar year  $y$  through August 31 of calendar year  $y+1$  (i.e., fishing year 2021 covers September 1, 2021 through August 31, 2022). This change was made to better align the data sets and modeled population dynamics to the red drum life cycle (i.e., fall spawning and an assumed biological birthdate of September 1). With this year definition, age data no longer need adjustments for the January 1 birthdate convention used for a calendar year and each age class in this assessment experiences a full 12 months before

advancing to the next age class. This also aligns the assessment year definition with the management year definition for some states that specifically set regulations based on a fishing year definition (e.g., North Carolina).

## **2 LIFE HISTORY**

### **2.1 Stock Definitions**

Red drum inhabit nearshore and estuarine waters of the U.S. Atlantic coast from Massachusetts to Florida and the Gulf of Mexico (GoM) from Florida to northern Mexico (Lux and Mahoney 1969; Mercer 1984). Despite encountering an occasional individual further north, the current distribution of red drum in the Atlantic Ocean, as indicated by commercial and recreational landings, primarily extends from southern Florida to the Chesapeake Bay, with infrequent, low catches in states north of the Chesapeake Bay. Early stock assessments (Section 1.3.1) divided this distribution into a northern stock (North Carolina through New Jersey) and a southern stock (South Carolina, Georgia, and the eastern coast of Florida) based on differences identified in life history characteristics (maximum age, growth, and maturity), as well as movement information from tagging data. Seyoum et al.'s (2000) initial mitochondrial genetic work on red drum indicated a weak subdivision of red drum into GoM and Atlantic components with a genetic transition occurring around the southern Florida peninsula between Sarasota Bay and Mosquito Lagoon, supporting the separate management of these populations. Large-scale genetic analyses have been conducted on red drum in the GoM by Gold et al. (2001) and Gold and Turner (2002).

Based on mitochondrial and microsatellite data, estuaries within the GoM showed temporal, but not spatial stability in allele frequencies. Further analyses of spatial patterns indicated the variability was not able to be partitioned into discrete geographic subpopulations, instead showing a pattern of isolation by distance. The proposed model of population structure fits well with gene flow predicted by life history and due to their estuarine-dependent recruitment; a steppingstone model where gene flow primarily occurred among adjacent estuaries was described with geographic neighborhoods limited to 700-900 km. Additionally, the degree of genetic divergence detected was similar between the two markers, indicating the occurrence of sex-biased gene flow, due to female mediated dispersal and/or male philopatry.

Two early studies have addressed red drum population structure within the Atlantic (mitochondrial sequence data, Seyoum et al. 2000; microsatellite data, Chapman et al. 2002), both indicating little to no level of spatial structuring among estuaries. However, the Atlantic spatial scale of both projects was limited and likely confounded by low sample sizes.

Additionally, an estuarine-collapsed analysis indicated temporal heterogeneity in the SC evaluation and was interpreted as a potential temporal instability of the reproductive pool (Chapman et al. 2002). Chapman et al. (2002) estimated a variance effective population size ( $N_e$ ) of Atlantic red drum using the temporal method of Waples (1989), which was an order of magnitude lower than estimates of female  $N_e$  in the GoM (Turner et al. 1999). However, due to

red drum overlapping generations, an estimate of  $N_e$  requires a modification based on age specific life history information (Jorde and Ryman 1995). At that time, the only correction factor available for red drum was based on GoM fish (Turner et al. 1999); however, the appropriateness of those data for Atlantic red drum is unlikely based on suspected age structure differences resulting from differential commercial fishery impacts during the 1980s. Therefore, determination of age-specific survival and birth rates are needed to determine accurate estimates of  $N_e$  for Atlantic red drum.

More recently, the South Carolina Department of Natural Resources (SCDNR) used genetic samples from adult red drum collected from a multi-state longline surveys and other sampling efforts to evaluate genetic structure from NC to FL (Cushman et al. 2014). Temporal genetic differentiation was tested for within each of six sampling sites from NC to FL and found to be insignificant. Spatial genetic differentiation was then tested between the six sampling sites during the spawning season and non-spawning season. Significant differentiation was detected between NC and all southern sample sites (SC-FL) during the spawning season, but not during the non-spawning season. This work suggests a genetic break does exist between NC and locations south of NC during spawning, but some mixing of adults occurs during the non-spawning season. This mixing is less of a concern based on current management of the defined stocks which protects adult fish from harvest (i.e., no mixed stock harvest). Estimates of  $N_e$  also supported the greater abundance of the southern stock estimated in previous stock assessments.

Previous stock assessments have defined the unit stocks as a southern stock, individuals from South Carolina and south, and as a northern stock, individuals from North Carolina and north. Questions arose within the SAS as to whether the state line was the most appropriate definition between these two stocks, or would another location be a more appropriate boundary between these two stocks. Using visual observations of the North Carolina traditional tag and recapture data since 2014 ( $n=1,680$ ), we examined whether a different geographic boundary between the stocks may exist.

An examination of the North Carolina tagging data revealed most individuals tagged in North Carolina stayed within the state or moved north. There were four individuals that moved south into South Carolina. Waterbodies that correspond with the NC Trip Ticket data (to promote ease of splitting sampled data) were visually inspected with tag and recaptured locations plotted to determine if any area had relatively low occurrence of red drum recaptured on opposite sides of the waterbodies. The waterbody with the lowest number of red drum that crossed the examined boundaries was the White Oak River, where only thirty-seven fish (2.2% of recaptures) were tagged and recaptured on opposite sides of the boundary. Red drum tagged and recaptured in South Carolina were not examined in this analysis. Age frequencies and estimated von Bertalanffy growth rates were then examined for red drum captured south of the White Oak River. The growth rates from red drum captured south of White Oak River were compared to the growth rates of red drum captured from the rest of the North Carolina and growth rates from red drum captured in South Carolina.

Inversely weighted von Bertalanffy growth models were then developed with the northern North Carolina age-length data (n=12,465), the southern North Carolina age-length data (n=1,775), and the South Carolina age-length data (n=94,252). Fractional ages were used in the analysis. The von Bertalanffy growth models were then compared using an Analysis Residuals Sum of Squares (ARSS).

### North NC versus Southern NC

Only 1,775 red drum were captured in or south of the White Oak River compared to the 12,465 captured north of the river. Most individuals captured were age 0, 1, or 2 with only 1.6% of red drum captured in White Oak River or south being age 3 or older compared to 10.4% of red drum north of White Oak being age 3 or older (Figure 1, ages 0-2 were removed from figure to demonstrate the less frequently captured age distributions). The von Bertalanffy growth parameters indicated red drum captured north of the White Oak River grew larger but slower than red drum captured in or south of the White Oak River ( $p < 0.0001$ ,  $F = 389.7$ ,  $df = 14,234$ , Table 3, Figure 2). However, the difference could be due to the lack of older individuals captured from White Oak River south.

### SC versus Southern NC

The 1,775 red drum captured in or south of the White Oak River were compared to the 94,252 red drum captured in South Carolina. Most individuals captured were age 0, 1, or 2, with only 1.6% of red drum captured in White Oak River or south being age 3 or older compared to 19.8% of red drum captured in SC being age 3 or older (Figure 3, ages 0-2 were removed from figure to demonstrate the less frequently captured age distributions). The von Bertalanffy growth parameters indicated red drum captured south of the White Oak River grew larger but slower than red drum captured in SC ( $p < 0.0001$ ,  $F = 235.6$ ,  $df = 96,021$ , Table 4, Figure 4). However, the difference could be due to the lack of older individuals captured from White Oak River south.

In conclusion, there was not sufficient data in the southern part of North Carolina to distinguish if those individuals were part of the southern stock, northern stock, or were located in a transition zone with individuals from both stocks. The SAS decided to stay with the prescribed stock definition outlined in the previous stock assessments and simulation assessment.

## **2.2 Migration Patterns**

Adult red drum make seasonal migrations along at least some parts of the Atlantic coast. In the spring, adults move north and inshore, but offshore and south in the fall. Overall, adults tend to spend more time in coastal waters after reaching sexual maturity. However, they do continue to frequent inshore waters on a seasonal basis. In the Indian River Lagoon (IRL), Florida, limited seasonal migrations, including some movement to coastal inlets in fall during the spawning season, have been detected (Reyier et al. 2011). In Mosquito Lagoon (northern IRL), a portion

of the adult population remain within the estuary where documented spawning occurs (Johnson and Funicelli 1991; Reyier et al. 2011).

Tagging information provided the best insight into the movement and migration of red drum along the Atlantic coast. Each state, from Georgia to Virginia, has participated in some form of tagging program (Section 4.3). Volunteer angler programs are or have been active in each state, in which trained volunteers participate by tagging fish and reporting tagged fish when recaptured. Other programs include agency staff tagging and cooperative projects with local commercial harvesters. Almost every program relies heavily on angler returns for recapture information.

Despite differences in state-to-state programs, there is evidence of adult red drum movement between Virginia and North Carolina. Data suggest red drum movement into Virginia waters from North Carolina in late May. The fish appear to stay in the area from August through September before they ultimately move during fall months to North Carolina waters where the fish appear to overwinter. Movement of red drum tagged in North Carolina over 25 years is summarized in Bacheler et al. (2009). The study, based on 6,173 tag returns for red drum of all sizes, found limited movement of red drum from North Carolina to adjacent states, although some adult red drum migrated seasonally to Virginia in the spring, returning the following fall. The study noted that the current stock split between North Carolina and South Carolina appeared to be an appropriate ecological division for the stock.

An interesting pattern of movement, or lack of movement, was observed from fish overwintering in the area of power plants. The most productive of these areas was the Elizabeth River Hot Ditch area, in Virginia. Rather than migrating out of the Chesapeake Bay during fall to North Carolina waters (considered the usual pattern for sub-adult red drum in the northern stock), fish in this area were observed over-wintering in bay tributaries in the area of power plants. The cycling of river water through the plants resulted in discharges of warmed water sufficient to maintain adjacent areas at temperatures suitable for the fish (as well as forage the fish could use - crabs, finger mullet, mummichogs, etc.). Similar patterns were observed, to a lesser degree, at another nearby power plant (SEDAR 2009b).

Programs in the southern states (Georgia and South Carolina) provided evidence of limited movement as well. For example, of 1,780 fish tagged in Georgia, 85.3% were recaptured within state waters, 11.0% were recaptured in South Carolina, and 3.7% were recaptured in Florida. In South Carolina, fish tagged in the SCDNR sub-adult tagging program were primarily recaptured within 30 miles (96.4%; SEDAR 2009b). An additional working document on movement distances by South Carolina red drum tags that were recaptured by recreational anglers (Arnott 2015b) indicated more than 95% of red drum were recaptured within 125 miles of their release location, even after five or more (up to 18) years at large. Of 12,754 tags with known recapture locations, 79 were recaptured in North Carolina, 12,657 in South Carolina, 13 in Georgia and 5 in Florida (SEDAR 2009b).

This analysis was updated in the current benchmark assessment using tagging data through 2021, finding broadly similar results when considering a much larger ( $n = 47,520$ ) sample size of recaptured fish with known recapture locations. Of these, 99.7% ( $n = 47,376$ ) were recaptured in South Carolina with only 144 (0.3%) recaptured in neighboring states: 83 recaptured in North Carolina, 31 in Georgia, 29 in Florida, and 1 in New Jersey. These patterns held when considering only recaptures of adult ( $> 750$  mm total length (TL);  $n = 6,905$ ) fish, with 99.8% ( $n = 6,890$ ) being recaptured in South Carolina. Further, looking at cumulative percentage recaptured as a function of straight-line distance, regardless of age, most were recaptured within 50 km of their original tagging location with only 147 fish recaptured  $>150$  km (maximum 467 km) from their original tagging location, though there was a tendency for larger distances moved with age (Figure 5).

The genetic work by SCDNR also suggests some movement of adult red drum between SC and NC during non-spawning seasons. However, these adult fish do appear to return to their respective stock during the spawning season.

### **2.3 Age and Growth**

Age data available for red drum along the Atlantic coast of the U.S. were collected, processed, read, and supplied by each of the state's agencies and academic institutions from Virginia through Florida. Otoliths are the primary ageing structure collected from red drum. They produce clearly interpretable annual growth bands and the age estimates have been shown to be precise (ASMFC 2008) and considered highly accurate. In contrast, age estimates from scales are only considered accurate through age-4 (ASMFC 2008), though a preliminary paired study from SCDNR suggested biased age determinations using scales began manifesting as early as age-3 ( $n = 519$ ; Figure 6; J. Ballenger, SCDNR, pers. comm.). This study found an absolute agreement of only 83% and a significant bias in scale ages (relative to otolith derived ages) as indicated by Bowker's symmetry test and other tests. Hence, the SAS recommended discarding scale derived age estimates from consideration in the current assessment. Additional details on age processing and reading are available in SEDAR 2015a.

A total of 71,355 otoliths were assigned ages for red drum from years 1981 – 2022 (Table 5). The vast majority of aged-fish were 0 to 2 years old (91%) and ages 0 –5 comprised 95% of the data (Table 5).

Age data for red drum from the northern stock constituted 57.9% ( $n = 41,301$  otoliths) and the southern stock 42.1% ( $n = 30,054$  otoliths; Table 6, Figure 7a). The number of ages sampled annually by stock was very low in the early 1980s but began increasing in the mid-1980s through the late 2010s where it peaked at greater than 3,000 samples annually. Since, the total number of age samples collected annually began decreasing through 2022 and were likely impacted by COVID-19 during years 2020 – 2021 though greater than five hundred individuals have been aged annually every year since 1986. North Carolina provided 55.9% ( $n = 39,885$  otoliths) of samples, followed by South Carolina (28%;  $n = 19,949$  otoliths), Georgia (8.7%;  $n = 6,241$ ), Florida (5.4%,  $n = 3,864$ ), and Virginia (1.9%;  $n = 1,330$ ; Table 6, Figure 7b).

Ages sampled from the fishery-independent sources ( $n = 53,948$  otoliths; Table 7, Figure 8) constituted 75.7% of all ages, while ages sampled from fishery dependent sources ( $n = 17,347$  otoliths; Table 7, Figure 8) made up 24.3%.

### 2.3.1 Maximum Age

The current maximum observed age of red drum based on sectional otoliths is 62 years in the northern stock and 41 years in the southern stock, unchanged from the previous assessment.

### 2.3.2 Growth

Length-at-age data were restricted to ages based on otoliths and containing complete information on year, month, state, fishery, and length. Total length observations were grouped by calendar age per stock and iteratively Z-scored; outliers were removed using threshold values of  $\pm 8$  in the first iteration and values of  $\pm 4$  in the second iteration. Calendar ages were converted to biological (i.e., fractional monthly) ages using an assumed birthdate of September 1.

Red drum length-at-age displayed fast growth through ages 4 – 5 and fish from the northern stock grew to larger asymptotic lengths than the southern stock (Figure 9). Diminished samples of adults and older individuals can also be seen as red drum move out of the estuaries and to the offshore environment.

Red drum growth has long been understood to not be described well with some of the traditional growth models like the von Bertalanffy growth function (Porch et al. 2002; Cadigan 2009). There are strong seasonal influences on growth as well as indications of changing growth rates over the age range of the stocks that result in poor fits with traditional growth functions. Alternative growth estimates are available (Porch et al. 2002; Cadigan 2009), as well as empirical estimates of length-at-age, but these options are not compatible with growth options in the SS framework used in this assessment and the prior simulation assessment (ASMFC 2022).

Therefore, an alternative growth function that allows for changing the von Bertalanffy growth coefficient parameters ( $K$ ) across ages (Methot et al. 2023; age-varying  $K$  growth) was used to generate stock-specific growth patterns. The growth function includes the traditional von Bertalanffy growth parameters for asymptotic length ( $L_{inf}$ ) and the growth coefficient ( $K_{base}$ ), but also allows for multipliers of the  $K$  parameter at user-specified older ages thereby giving flexibility to the growth curve. The  $K_{base}$  parameter is used in growth calculations for the youngest age (here, age-0) and any subsequent ages until an age break point where a  $K$  multiplier is specified. At this age break point, the multiplier is applied to the  $K_{base}$  and the product serves as the new  $K$  parameter for any subsequent ages unless another age break point is specified. If another age break point is specified, the associated  $K$  multiplier is applied to the  $K$  parameter and the product becomes the new  $K$  parameter. This repeats for any age break points across the age range. The number of  $K$  multipliers can range from one to one less than

the number of ages in the age range. The parameterization of the von Bertalanffy growth function used here also includes a parameter for the length ( $L_{min}$ ) at a user-specified minimum age ( $A_{min}$ ) when fish begin to grow according to the growth function. In addition to the von Bertalanffy growth curve describing expected mean length-at-age, the models use coefficients of variation (CVs) for size at the smallest sizes and the largest sizes in the growth function with interpolation of CVs between these sizes to describe variation in growth around the expected growth curve.

To estimate at what ages these break points would occur, data by stock were first summarized into mean lengths-at-age. Next, segmented regression using the R (R Core Team 2024) package “segmented” (Muggeo 2017) was applied to the biological mean length-at-age data to identify the age break points. This method utilizes iterative procedure algorithms and requires starting values for the break point parameters. Studies in life history theory suggest changes in growth rate can occur in connection with physiological processes, such as maturity onset; therefore, age-at-50% maturity ( $A_{50}$ ) values were used as initial starting values to approximate onset of maturity (Scott and Heikkonen 2012; Baulier and Heino 2008). Segmented regression models were explored using both one break and two breaks and models were compared using AIC. For both stocks, the model which identified two breaks had the lower AIC value. In the northern stock, break points were identified for ages 2.06 and 6.35 years (Figure 10a) while in the southern stock, break points were identified for ages 1.26 and 6.19 years (Figure 10b).

Lastly, an age-varying  $K$  growth model was constructed in Microsoft Excel for each stock in an effort to replicate how the length-at-age data are internally modeled within the SS framework using the age-varying  $K$  growth model option. The model was set-up using biological age, the associated mean length of that age, growth parameters (i.e.,  $L_{inf}$ ,  $K_{base}$ , and the  $K$  multiplier parameters), and the predicted length for each biological age. The break points estimated in the segmented regressions were applied to the  $K$  multipliers of the biological monthly age closest to that value (e.g., age 2.06 becomes age 2.08 and age 6.35 becomes age 6.25). Residual sum of squares (RSS) were calculated between the observed and predicted values and Excel’s Solver function was utilized to minimize the RSS by changing the  $L_{inf}$ ,  $K_{base}$ , and the  $K$  multiplier parameters. Model AIC was then calculated as  $N * \ln\left(\frac{RSS}{N}\right) + 2(K + 1)$  where  $N$  is the number of mean length-at-age observations, RSS is the residual sum of squares, and  $K$  is the number of parameters in the model.

For the northern stock, the best fitting age-varying  $K$  growth model estimated parameters  $L_{inf} = 1,253$  mm,  $K_{base} = 0.259$ ,  $K_{mult1} = 0.909$  at age 2.083 (corresponding  $K = 0.235$ ), and  $K_{mult2} = 0.197$  at age 6.250 (corresponding  $K = 0.046$ ; Figure 11). For the southern stock, age-varying  $K$  growth model estimated parameters  $L_{inf} = 1,132$  mm,  $K_{base} = 0.296$ ,  $K_{mult1} = 0.731$  at age 1.250 (corresponding  $K = 0.216$ ), and  $K_{mult2} = 0.192$  at age 6.167 (corresponding  $K = 0.041$ ; Figure 12). The SAS used these parameter as starting values for the age-varying  $K$  growth model option within SS for each respective stock.

This methodology also represents a change from how the age-varying  $K$  growth model was implemented for the operating model of the simulation assessment (ASMFC 2022) and is



considered more objective and parsimonious. Age breaks were identified through modeling of changes in mean length-at-age and the number of age breaks were reduced from five (northern) and four (southern) to two. However, more work is needed on this growth model than the time that was available during this assessment. For example, it would be beneficial to build this model within a framework (e.g., R or ADMB) that would allow for a bootstrapping routine to estimate the variances of each parameter.

## **2.4 Reproduction**

Herein the SAS reports on the understanding of red drum reproduction, based on peer-reviewed studies, previous assessments, and data submitted by data providers for the current benchmark stock assessment. Some of the data submitted for the current assessment represent gross sex and maturity assessments based on macroscopic examination of gonadal structures in sacrificed fish. Preliminary analysis looking at size- and/or age-based maturity patterns using this macroscopically derived information suggested severe bias in maturity ogives and a conflict with histologically derived information. Previous paired comparisons at the SCDNR suggested substantial disagreement between macroscopically and microscopically derived maturity states (J. Ballenger, pers. comm.; Wenner 2000) and histologically derived maturity information is generally considered best available science (Brown-Peterson et al. 2011; Wilson & Nieland 1994). As such, any updated analyses for reproductive information conducted as part of this assessment relied solely on histologically derived data. This histologically derived information is supported by hydroacoustic data (Lowerre-Barbieri et al. 2008). Due to limited availability of data from the Atlantic coast region, where necessary (e.g., fecundity estimates) we incorporated data from Gulf of Mexico red drum populations.

### **2.4.1 Spawning Seasonality**

Spawning seasonality is consistent, if with a slight latitudinal cline (shifted slightly later further South), throughout the species range in the Gulf of Mexico and along the Atlantic coast of the US. For fish found at the lowest latitudes along the Gulf and Atlantic coasts of Florida, the spawning season peaks between September and October (Murphy and Taylor 1990). Westward along the northern Gulf of Mexico spawning occurs between mid-August to September. Along the Atlantic coast, hydroacoustic data suggests red drum congregate and spawn between August and mid-October along coastal Georgia (Lowerre-Barbieri et al. 2008) and based on histological data spawn from mid-August to September along coastal South Carolina (J. Ballenger, pers. comm.). Along the coast of North Carolina, spawning peaked between August and September based on GSI and hydroacoustic data (Ross et. al. 1995; Luczkovich et al. 1999). In combination, these studies are indicative of a spawning season generally between August and October, with a 45–60-day season in a given location.

### **2.4.2 Sexual Maturity**

Previously published information on red drum maturity was available from North Carolina, South Carolina, the Florida Atlantic coast (Indian River Lagoon) and Florida Gulf of Mexico coast. In Florida, using specimens collected from both Tampa Bay and the Indian River Lagoon,

Murphy & Taylor (1990) suggested sexual differences in maturity rates, with females maturing at larger sizes (550-899 mm FL) and older ages (3-6 years old) than males (350-799 mm FL; ages 1-3). Interpolated lengths of 50% maturity for males and females in Tampa Bay were 529 mm and 825 mm FL, respectively (Murphy & Taylor 1990). Similarly, in the Indian River Lagoon along the Atlantic coast length-at-50% maturity for males and females was interpolated as 511 mm and 900 mm FL, respectively (Murphy & Taylor 1990). Sexually dimorphic maturity patterns were also noted in South Carolina, with histological analysis suggesting females matured at larger sizes (691-840 mm total length (TL)) and ages (3-5 years old) than males (573-785 mm TL; ages 2-3; Wenner 2000). This study found all females and males were mature by 5 and 4 years old, respectively, with calculated sizes- and ages-at-50% maturity of 792 mm TL and 4.3 years old for females and 713 mm TL and 3.5 years old for males (Wenner 2000). Ross et al. (1995) investigated the maturity of red drum in North Carolina, finding females and males attained 100% maturity by ages 4 and 3, respectively, with ages of first maturity of 3 and 2. Unsexed immature red drum ranged in size from 250-627 mm TL and 0-1 years old, while the smallest mature female was 773 mm TL and male was 520 mm TL (Ross et al. 1995). Lengths-at-50%-maturity were estimated to be 801-820 mm TL and 621-640 mm TL for females and males, respectively, with 57% of age-3 females and >50% age-2 males being mature (Ross et al. 1995). The Ross et al. (1995) study also noted senescence in two old females (ages 49 and 51), with ovaries severely atrophied and oogenic tissue absent, though five other old females (ages 40-52) were spent or resting.

During SEDAR 44, additional analyses were performed using data available from South Carolina (n = 5,540 fish; Arnott 2015a) and a re-analysis of the Ross et al. (1995) data (n = 728 fish) using Brown-Peterson et al. (2011) methodologies so that maturity could be statistically compared between North Carolina and South Carolina. The analyses found significant differences between North Carolina and South Carolina in relationships between both maturity-at-size and maturity-at-age, as well as significant differences between males and females. Based on results of this updated analysis, maturity-at-age was calculated separately for the northern and southern stocks in SEDAR 44 (ASMFC 2017b), a departure from previous assessments which relied on maturity estimates from Ross et al. (1995).

During the current assessment, maturity ogives were again re-assessed using updated histological maturity assessments available from South Carolina (analysis in previous assessment used a mix of macroscopic and histologically derived maturity information for the southern stock), North Carolina (Ross et al. 1995 data plus new data from NCDMF study), and to reflect our fishing year definition (September 1 – August 31) and assumed September 1 birthdate in the current assessment. Best fit logistic size- and age-at-maturity ogives are provided in Table 8 and Table 9, respectively, along with ogives used in SEDAR 44. Lengths-at-50% maturity for females slightly decreased relative to SEDAR 44 in both stocks with the addition of new data, with 50% maturity at 766 mm (95% CI: 753-778 mm TL) and 836 mm (95% CI: 818-853 mm TL) TL for the southern and northern stocks, respectively (Table 8, Figure 13 and Figure 14). Similarly, the ages-at-50% maturity for females slightly decreased relative to SEDAR 44 in both stocks with the addition of new data and shift in year determination and subsequent fractional age assignment, with 50% maturity at 4.2 (95% CI: 4.0-4.4 yrs) and 3.5

(95% CI: 3.4-3.7 yrs) years for the southern and northern stocks, respectively (Table 9, Figure 15 and Figure 16). Predicted lengths- and ages-at-maturity from SEDAR44 and the current assessment are provided in Table 10 and Table 11, respectively. Note the pronounced shift with a higher proportion of mature fish at a younger age is primarily driven by our change in the definition of year (September 1 – August 31 vs. January 1 – December 31) and assumed birthday (September 1 vs. January 1) in the current assessment relative to SEDAR44; these changes in assumptions did not and was not expected to have a similar effect on length-at-maturity estimates.

### **2.4.3 Sex ratio**

Most literature supports the assumption of a 1:1 sex ratio for the red drum population. For example, along the Atlantic coast in North Carolina Ross et al. (1995) found a 1:1 (349 males:373 females) sex ratio. In the northern Gulf of Mexico, the sex ratio for spawning adults was also 1:1 (Wilson & Nieland 1994). The one dissenting study is from South Carolina, where they found sex ratios differed from 1:1 overall and within different gears and locations (Wenner 2000). They observed an overall sex ratio of 0.80:1 females:males across all data. In estuarine waters, where 95% of all individuals sampled were juveniles, they observed a sex ratio of 0.76:1 females:males; the pattern switched for adults where the ratio was 1.62:1 females:males.

Given the two studies reporting a 1:1 sex ratio and the differences in sex ratio by location in South Carolina, we recommended to assume a 1:1 sex ratio for the current assessment. This is consistent with previous assessments in the region.

### **2.4.4 Spawning Frequencies**

For the current assessment, histologically derived reproductive stage information available from South Carolina for adult female red drum captured from mid-August through September was used to investigate spawning frequencies of adult red drum along the Atlantic coast ( $n = 168$  mature females). The probability of spawning on a given day was calculated as the proportion of females actively spawning (Brown-Peterson et al. 2011) divided by the number of mature females encountered, with a probability of spawning using the combined data set of 29.8% (Table 12). This equates to a spawning frequency (Spawning Frequency =  $1/\text{probability of spawning}$ ) of approximately 3.4, which in turn equates to approximately 13.4 spawns (# of spawns = spawning season/spawning frequency) over a 45-day spawning season (Table 12). These new estimates from the Atlantic coast were consistent with estimates available from the northern Gulf of Mexico, where Wilson & Nieland (1994) estimated a spawning frequency of females of every 2 to 4 days.

### **2.4.5 Spawning Location**

Spawning most likely occurs in the nearshore areas adjacent to channels and passes and may also occur over nearshore continental shelves (Murphy and Taylor 1990; Lowerre-Barbieri et al. 2008). Spawning locations in South Carolina were also associated with passes and channels (Wenner 2000). More recent evidence suggests that, in addition to nearshore vicinity habitats,

red drum also utilize high-salinity estuarine areas along the coast (Murphy and Taylor 1990; Johnson & Funicelli 1991; Nicholson and Jordan 1994; Woodward 1994; Luczkovich et al. 1999; Beckwith et al. 2006).

#### **2.4.6 Batch Fecundity**

Batch fecundity estimates vs. fork length (FL), gonad-free body weight, age in year, and eviscerated body weight were generated by Wilson and Nieland (1994) for red drum from the northern Gulf of Mexico from 1986 to 1992. The mean batch fecundity was 1.54 million ova. Fish ranged from 3-33 years of age, had a FL range of 697-1005 mm, and a batch fecundity range of 0.16-3.27 (ova x 10<sup>6</sup>).

Data on batch fecundity for the current assessment was made available from a Florida Fish and Wildlife Research Institute study conducted in 2008 in Tampa Bay. Fish (n = 143) ranged from 5-22 years of age, 833-1072 mm TL, 5,615-12,475 g wet weight, and a batch fecundity of 0.10-4.58 (ova x 10<sup>6</sup>; S. Burnsed, pers. comm.). The strongest relationship was between batch fecundity and TL, using the linear regression  $Fec = 7,172,211 * \log(TL) - 46,549,889$  (R<sup>2</sup> = 0.21; Figure 17).

However, a drawback to this data set was its geographic location (Tampa Bay, FL in the Gulf of Mexico) and the lack of smaller mature females (smallest female 833 mm TL; larger than Atlantic length-at-50%-maturity) necessitating extrapolation beyond the range of the data if used in the current assessment.

As such, though a preliminary investigation of reproductive potential-at-age was calculated using information on female proportion mature-at-age, batch fecundity-at-age, and number of spawns-at-age to calculate annual fecundity-at-age, the SAS decided to continue use of female spawning stock biomass (calculated using only female maturity-at-age) as a proxy for reproductive potential. Future work is needed to collect batch fecundity estimates from the Atlantic coast stocks and to investigate spawning frequency across spatial areas and age.

#### **2.4.7 Recruitment Drivers**

In 2020, Goldberg et al. published an analysis of North Carolina young-of-year red drum data through 2016 that identified a relationship between year class strength and environmental variables. Specifically, the analysis found earlier shifts to favorable coastal wind conditions (summed hourly wind speeds of winds blowing towards the coast) in late August was the most consistent environmental feature associated with recruitment success. Favorable winds in early October and across the recruitment season (late July through early October) were also found to be significant variables explaining recruitment success. Elevated late July average sea surface temperature (SST) was found to be an additional significant driver of recruitment success and positive associations were found between recruitment and chlorophyll concentrations, though it was noted that more spatially resolved chlorophyll concentration data are needed.

These relationships were evaluated here with updated data and expanded to areas in the southern red drum stock as exploration of a potential recruitment covariate data stream for

assessment models. Environmental data were updated through 2022 from the same climate stations used by Goldberg et al. 2020 (North Carolina State Climate Office station KHSE for wind and NOAA National Data Buoy Center Stations DSLN7 and 41025 for SST) and two new stations identified in South Carolina (NOAA National Data Buoy Center Station 41004 southeast of Charleston) and Georgia (NOAA National Data Buoy Center Station 41008 southeast of Savannah) coastal waters. The same recruitment index used by Goldberg et al. 2020 (North Carolina Bag Seine Survey fall age-0 index) was used for analysis of North Carolina recruitment. The South Carolina Trammel Net Survey age-1 index lagged back one year and the Georgia Gill Net Survey age-0 fishing year index were used for analyses of southern stock recruitment.

Relationships between indices of abundance and environmental indices were examined with correlation analysis given the linear relationship between recruitment and wind and SST indices suggested in the original study. Environmental indices were developed in bi-weekly (early and late month periods), monthly, and seasonal temporal scales as done previously (Goldberg et al. 2020) to determine if any of the various temporal scales were more important for recruitment success. Favorable wind indices used the same wind directions for all three stations (winds originating from the N, NE, E, SE). SST data were only analyzed for North Carolina and not South Carolina or Georgia given preliminary results for North Carolina indicated a lack of support for a relationship between recruitment and SST. Regression models including surrounding stations (NOAA National Data Buoy Center Stations 41002 and 44014) Goldberg et al. 2020 used to gap-fill missing SST data for the stations used in the analysis (DSLN7 and 41025) were updated with additional years of data and used for gap-filling in this analysis as well. Given the data limitations and weaker support for chlorophyll concentrations, these data were not used in this analysis.

Correlation results between North Carolina favorable wind and recruitment indices for the same time series used by Goldberg et al. 2020 were significant ( $p$ -value $<0.05$ ) for the same temporal periods significant in the original study (late August, early October, and seasonal; Table 13). These results held for the early October and seasonal indices using the update time series, but not the late August index. The recruitment index and seasonal wind index both show higher average levels at the beginning of the time series followed by stable and variable indices since around 2000 (Figure 18). No significant correlations were found between recruitment and SST indices (Table 14).

There are limitations of wind data for the South Carolina buoy, precluding comparison of indices for the 1990–1999-year classes, except 1997 (Figure 19). However, correlation results do indicate a positive correlation between the SC recruitment index and the early September favorable wind index from this buoy (Table 15). Both indices show sharp declines in 2010 with continued low values through the early to mid-2010s (Figure 19). The wind index does show improvement in wind conditions since 2017 that is not reflected in the recruitment index. This may be indicative of fishing impacts on the population or other environmental drivers controlling recruitment.

Only marginally significant ( $p$ -value $<0.1$  and  $>0.05$ ) positive correlations were detected for the Georgia recruitment index and wind indices from the Georgia buoy (Table 15). The recruitment index is not available prior to 2002, which is a period when there were higher favorable wind index values. Comparison of the recruitment index with the wind index with the strongest marginally significant correlation (early August) show both indices are highly variable, but the wind index declines to lower levels in the late 2000s, while the recruitment index only declines to lower levels for a short period in the early 2010s (Figure 20).

All combinations of wind indices and recruitment indices in the southern stock were compared, and significant or marginally significant positive correlations were only found between recruitment indices and wind indices from the same state, indicating some localized spatial coherence in these trends (Table 15).

Although significant, positive correlations were detected between recruitment indices and wind indices, these correlations were generally weak ( $r<0.5$ ) or need some approach to spatial aggregation (southern stock) due to lack of broader spatial correlation. This limits the utility of wind indices as an environmental variable to predict recruitment in the assessment models on their own. This is likely due to recruitment driver mechanisms being complex and influenced by a number of abiotic and biotic (e.g., red drum SSB, red drum juvenile prey availability) factors. The wind indices analyzed here provide a starting point for identifying these mechanisms and continuing this work in future stock assessments.

## 2.5 Natural Mortality

Natural mortality,  $M$ , characterizes all causes of natural (i.e., non-fishing) mortality such as predation, starvation, disease, and senescence (Gulland 1983; Hilborn and Walters 1992) but may also include some forms of human-induced mortality not due to fishing (Maunder et al. 2023). While it is one of the most influential parameters within fisheries stock assessment, it is rarely observed or measured in fish populations; consequently, it is difficult to estimate and remains a large source of uncertainty within most assessment models (Vetter 1988, Hampton 2000, Maunder et al. 2023).  $M$  is commonly treated as a constant within stock assessment processes and textbooks (e.g., Hilborn and Walters 1992; Quinn and Deriso 1999; Haddon 2011), but application as a size-dependent or equivalent age-dependent function using a stock-specific growth function with constant  $M$  scaled to a fully selected age or range of ages (e.g., the ‘Lorenzen  $M$ ’ model) is becoming more commonly practiced in stock assessments conducted in the southeastern United States (Lorenzen 2022; Lorenzen et al. 2022).

Constant as well as size- and age-dependent estimates of natural mortality of red drum were explored using the approaches and recommendations presented in the recent review of natural mortality estimation methods by Maunder et al. (2023) and the ‘generalized length-inverse mortality (GLIM)’ paradigm presented by Lorenzen (2022). Where relevant, all natural mortality models assumed a von Bertalanffy growth parameterization where the growth coefficient,  $K$ , was allowed to vary by age. Constant  $M$  estimates were calculated based on the longevity model updated by Hamel and Cope (2022) where  $M = 5.4/t_{max}$  and  $t_{max}$  represents the

maximum age for each stock. These estimates of constant  $M$  were then converted to mortality-at-length and -age using the mortality-weight model described in Lorenzen (1996) where  $M_w = 3 * W^{-0.288}$  and the length-inverse model described in Lorenzen (2022) where  $M_L = M_{Lr}(L/L_r)^c$ . For the length-inverse model, the Hamel and Cope (2022) longevity-based estimate of constant  $M$  was used as the mortality at reference age and scaled so that the cumulative mortality rate predicted for ages 2 and greater agreed with the constant  $M$  estimate. For the mortality-weight model, the age-specific estimates were scaled following Hewitt and Hoenig (2005) where percent survival was equal to  $100 * e^{-M * t_{max}}$ .

Longevity estimates for red drum in the northern stock was  $t_{max} = 62$  years while in the southern stock it was  $t_{max} = 41$  years. The von Bertalanffy growth parameter values were based on the final growth models selected (Section 2.3.2) where  $L_{inf} = 1,253$  mm,  $K_{base} = 0.259$ ,  $K_{age2} = 0.235$ , and  $K_{age6} = 0.046$  for the northern stock and  $L_{inf} = 1,132$  mm,  $K_{base} = 0.296$ ,  $K_{age1} = 0.216$ , and  $K_{age6} = 0.041$  for the southern stock. Length-weight model parameters of red drum used within the mortality-weight model were obtained from the non-linear length-weight model converting maximum total length (mm) to total weight (g) where  $a = 1.65E-5$  and  $b = 2.931$  for the northern stock and  $a = 1.13E-5$  and  $b = 2.983$  for the southern stock. Constant mortality estimates based on the longevity model were found to be  $M = 0.087$  in the northern stock and  $M = 0.132$  in the southern stock.

Estimated mortality-at-age from the mortality-weight model ranged from  $0.349 - 0.038 \text{ yr}^{-1}$  in the northern stock and from  $0.517 - 0.104 \text{ yr}^{-1}$  in the southern stock (Table 16; Figure 21) where cumulative survival to the oldest age class was 0.49% and 0.50%, respectively. The length-inverse model estimated mortality-at-age from  $0.498 - 0.079 \text{ yr}^{-1}$  in the northern stock and from  $0.749 - 0.116 \text{ yr}^{-1}$  in the southern stock (Table 16; Figure 21) where cumulative survival to the oldest age class was 0.26% and 0.20%, respectively.

The SAS recommended estimates of natural mortality be size- or age-dependent and recommended the Lorenzen (2022) length-inverse model be used to inform natural mortality within the stock assessment models.

### **3 HABITAT DESCRIPTION**

Habitat information for red drum is summarized from a comprehensive report on sciaenid species habitat information completed by the ASMFC (Odell et al. 2017). See this report for additional detail on red drum habitat. In addition, fish habitat of concern (FHOC) designations for red drum were published by the ASMFC Habitat Committee in 2024 (ASMFC 2024).

#### **3.1 Spawning, Egg, and Larval Habitat**

##### Spawning Habitat

Red drum spawn from late summer to late fall in a range of habitats, including estuaries, and near inlets, passes, and bay mouths (Peters and McMichael 1987). Earlier studies illustrated spawning occurred in nearshore areas relative to inlets and passes (Pearson 1929; Miles 1950;

Simmons & Breuer 1962; Yokel 1966; Jannke 1971; Setzler 1977; Music & Pafford 1984; Holt et al. 1985). More recent evidence suggests red drum also use high-salinity estuarine areas along the coast for spawning (Murphy & Taylor 1990; Johnson & Funicelli 1991; Nicholson and Jordan 1994; Woodward 1994; Luczkovich et al. 1999; Beckwith et al. 2006; Renkas 2010). Several authors provide direct evidence of red drum spawning deep within estuarine waters of the IRL, Florida (Murphy & Taylor 1990; Johnson & Funicelli 1991). An intensive two-year ichthyoplankton survey consistently collected preflexion (2–3 mm) red drum larvae up to 90 km away from the nearest ocean inlet from June to October with average nightly larval densities as high as fifteen per 100 m<sup>3</sup> of water in the IRL (Reyier and Shenker 2007). Acoustic telemetry results for large adult red drum in the IRL further support estuarine spawning of this species within the IRL system (Reyier et al. 2011).

Spawning in laboratory studies have also appeared to be temperature-dependent, occurring in a range from 22° to 30°C but with optimal conditions between temperatures of 22° to 25°C (Holt et al. 1981). Renkas (2010) duplicated environmental conditions of naturally spawning red drum from Charleston Harbor, SC in a mariculture setting, and corroborated that active egg release occurred as water temperature dropped from a peak of ~30° C during August. Cessation of successful egg release was found at 25°C, with no spawning effort found at lower temperatures (Renkas 2010). Pelagic eggs, embryos, and larvae are transported by currents into nursery habitats for egg and larval stages, expectedly due to higher productivity levels in those environments (Peters & McMichael 1987; Beck et al. 2001).

### Eggs and Larvae Habitat

Researchers commonly encounter red drum eggs in southeastern estuaries in high salinity, above 25 ppt (Nelson et al. 1991; Reyier & Shenker 2007; Renkas 2010). Salinities above 25 ppt allow red drum eggs to float while lower salinities cause eggs to sink (Holt et al. 1981). In Texas, laboratory experiments conducted by Neill (1987) and Holt et al. (1981) concluded that an optimum temperature and salinity for the hatching and survival of red drum eggs and larvae was 25°C and 30 ppt. Spatial distribution and relative abundance of eggs in estuaries, as expected, mirrors that of spawning adults (Nelson et al. 1991); eggs and early larvae utilize high salinity waters inside inlets, passes, and in the estuary proper. Currents transport eggs and pelagic larvae into bays, estuaries, and seagrass meadows (when present), where they settle and remain throughout early and late juvenile stages (Holt et al. 1983; Pattillo et al. 1997; Rooker & Holt 1997; Rooker et al. 1998; Stunz et al. 2002).

Larval size increases as distance from the mouth of the bay increases (Peters & McMichael 1987), possibly due to increased nutrient availability. Research conducted in Mosquito Lagoon, Florida, by Johnson & Funicelli (1991) found viable red drum eggs being collected in average daily water temperatures from 20°C to 25°C and average salinities from 30 to 32 ppt. During the experiment, the highest numbers of eggs were gathered in depths ranging from 1.5 to 2.1 m and the highest concentration of eggs was collected at the edge of the channel.

Upon hatching, red drum larvae are pelagic (Johnson 1978) and laboratory evidence indicates development is temperature-dependent (Holt et al. 1981). Newly hatched red drum spend



approximately twenty days in the water column before becoming demersal (Rooker et al. 1999; FWCC 2008). However, Daniel (1988) found much younger larvae already settled in the Charleston Harbor estuary. Transitions are made between pelagic and demersal habitats once settling in the nursery grounds (Pearson 1929; Peters and McMichael 1987; Comyns et al. 1991; Rooker & Holt 1997). Tidal currents (Setzler 1977; Holt et al. 1989) or density-driven currents (Mansueti 1960) may be used in order to reach a lower salinity nursery in upper areas of estuaries (Mansueti 1960; Bass & Avault 1975; Setzler 1977; Weinstein 1979; Holt et al. 1983; McGovern 1986; Peters & McMichael 1987; Daniel 1988; Holt et al. 1989). Once inhabiting lower salinity nurseries in upper areas of estuaries, red drum larvae grow rapidly, dependent on present environmental conditions (Baltz et al. 1998).

Red drum larvae along the Atlantic coast are common in southeastern estuaries, except for Albemarle Sound, and are abundant in the St. Johns and IRL estuaries in Florida (Nelson et al. 1991). Daniel (1988) and Wenner et al. (1990) found newly recruited larvae and juveniles through the Charleston harbor estuary over a wide salinity range. Mercer (1984) has also summarized spatial distribution of red drum larvae in the Gulf of Mexico. Lyczkowski-Shultz & Steen (1991) reported evidence of diel vertical stratification among red drum larvae found at lower depths less than 25 m at both offshore and nearshore locations. Larvae (ranging between 1.7 to 5.0 mm mean length) were found at lower depths at night and higher in the water column during the day. At the time of the study, the water was well mixed and the temperature ranged between 26° and 28°C. There was no consistent relationship between distribution of larvae and tidal stage. Survival during larval (and juvenile) stages in marine fish, such as the red drum, has been identified as a critical bottleneck determining their contribution to adult populations (Cushing 1975; Houde 1987; Rooker et al. 1999).

### **3.2 Juvenile and Adult Habitats**

#### **Juvenile Habitat**

Juvenile red drum use a variety of inshore habitats within the estuary, including seagrass meadows (where they exist), tidal freshwater, low salinity reaches of estuaries, estuarine emergent wetlands, estuarine scrub/shrub, submerged aquatic vegetation, oyster reefs, shell banks, and unconsolidated bottom (SAFMC 1998; Odell et al. 2017). Smaller red drum seek out and inhabit rivers, bays, canals, boat basins, and passes within estuaries (Peters and McMichael 1987; FWCC 2008). Wenner (1992) indicated red drum juvenile habitats vary slightly seasonally; most often between August and early October red drum inhabit small creeks that cut into emergent marsh systems and have some water in them at lower tides, while in winter, red drum reside in main channels of rivers ranging in depths from 10 to 50 feet (3-15 m) with salinities from one-half to two-thirds that of seawater. In the winter of their first year, 3- to 5-month-old juveniles migrate to deeper, more temperature-stable parts of the estuary during colder weather (Pearson 1929). In the spring, they move back into the estuary and shallow water environments. Studies show red drum inhabiting non-vegetated sand bottoms exhibit the greatest vulnerability to natural predators (Minello and Stunz 2001). Juvenile red drum in

their first year avoid wave action by living in more protected waters (Simmons and Breuer 1962; Buckley 1984).

In the Chesapeake Bay, juveniles (20-90 mm TL) were collected in shallow waters from September to November, but there is no indication as to the characteristics of the habitat (Mansueti 1960). Some southeastern estuaries where juvenile (and sub-adult) red drum are abundant are Bogue Sound, NC; Winyah Bay, SC; Ossabaw Sound, and St. Catherine/Sapelo Sound, GA; and the St. Johns River, FL (Nelson et al. 1991) and throughout SC (Wenner et al. 1990; Wenner 1992). They were highly abundant in the Altamaha River and St. Andrews/St. Simon Sound, GA, and the Indian River, FL (Nelson et al. 1991).

Peters and McMichael (1987) found juvenile red drum were most abundant in protected backwater areas, such as rivers, tidal creeks, canals, and spillways with freshwater discharge, as well as in areas with sand or mud bottom and vegetated or non-vegetated cover in Tampa Bay. Juveniles found at stations with seagrass cover were smaller in size and fewer in number (Peters and McMichael 1987). Near the mouth of the Neuse River, as well as smaller bays and rivers between Pamlico Sound and the Neuse River, surveys from the NCDMF indicate juvenile red drum were abundant in shallow waters of less than 5 feet (1.5 m). Habitats identified as supporting juvenile red drum in North Carolina can be characterized as detritus laden or mud bottom tidal creeks (in Pamlico Sound) and mud or sand bottom habitat in other areas (Ross & Stevens 1992). In a Texas estuary, young red drum (6-27 mm Standard Length, SL) were never present over non-vegetated muddy-sandy bottom; areas most abundant with red drum occurred in the ecotone between seagrass and non-vegetated sand bottom (Rooker & Holt 1997). In SC, Wenner (1992) indicated very small red drum occupy small tidal creeks with mud/shell hash and live oyster as common substrates (since sub-aquatic vegetation is absent in SC estuaries).

### Sub-Adult Habitat

The distribution of red drum within estuaries varies seasonally as individuals grow and begin to disperse. Along the South Atlantic coast, they use a variety of inshore habitats. Late juveniles leave shallow nursery habitats at approximately 200 mm TL (10 months of age). They are considered sub-adults until they reach sexual maturity at 3–5 years. It is at this life stage red drum use a variety of habitats within the estuary and when they are most vulnerable to exploitation (Pafford et al. 1990; Wenner 1992). Tagging studies conducted throughout the species' range indicate sub-adult red drum remain in the vicinity of a given area (Beaumarrige 1969; Osburn et al. 1982; Music & Pafford 1984; Pafford et al. 1990; Wenner et al. 1990; Ross & Stevens 1992; Woodward 1994; Marks & DiDomenico 1996; Adams & Tremain 2000; Troha 2023). Movement within the estuary is related to changes in temperature and food availability (Pafford et al. 1990; Woodward 1994).

Tagging studies indicate late age-0 and 1 year-old red drum are common throughout the shallow portions of the estuaries and are particularly abundant along the shorelines of rivers and bays, in creeks, and over grass flats and shoals of the sounds. During the fall, those sub-adult fish inhabiting the rivers move to higher salinity areas such as the grass flats and shoals of

the barrier islands and the front beaches. With the onset of winter temperatures, juveniles leave the shallow creeks for deeper water in the main channels of rivers (9–15 m) and return to the shallows in the spring. Fish that reside near inlets and along the barrier islands during the summer are more likely to enter the surf zone in the fall.

By their second and third year of growth, red drum are less common in rivers but are common along barrier islands, inhabiting the shallow water areas around the outer bars and shoals of the surf and in coastal inlets over inshore grass flats, creeks or bays. In the northern portion of the South Carolina coast, sub-adults use habitats of broad, gently sloping flats (up to 200 m or more in width). Along the southern part of the South Carolina coast, sub-adult red drum inhabit narrow (50 m or less), level flats traversed by numerous small channels, typically 5–10 m wide by less than 2 m deep at low tide (ASMFC 2002).

In general, habitats supporting juvenile red drum can be characterized as detritus or mud-bottom tidal creeks as well as sand and shell hash bottoms (Daniel 1988; Ross & Stevens 1992). Within seagrass beds, investigations show juveniles prefer areas with patchy grass coverage or sites with homogeneous vegetation (Mercer 1984; Ross & Stevens 1992; Rooker & Holt 1997). Wenner et al. (1990) collected post-larval and juvenile red drum in South Carolina from June 1986 through July 1988 in shallow tidal creeks with salinities of 0.8–33.7 ppt, although the preferred salinity range in the IRL, Florida is between 19–29 ppt (Tremain & Adams 1995).

#### Adult Habitat

Adults tend to spend more time in coastal waters after reaching sexual maturity. However, they continue to frequent inshore waters on a seasonal basis. Less is known about the biology of red drum once they reach the adult stage and accordingly, there is a lack of information on habitat utilization by adult fish. The SAFMC's Habitat Plan (SAFMC 1998) cited high salinity surf zones and artificial reefs as EFH for red drum in oceanic waters, which comprise the area from the beachfront seaward. In addition, nearshore and offshore hard/live bottom areas have been known to attract concentrations of red drum.

In addition to natural hard/live bottom habitats, adult red drum also use artificial reefs and other natural benthic structures. Red drum were found from late November until the following May at both natural and artificial reefs along tide rips or associated with the plume of major rivers in Georgia (Nicholson & Jordan 1994). Data from this study suggests adult red drum exhibit high seasonal site fidelity to these features. Fish tagged in fall along shoals and beaches were relocated 9–22 km offshore during winter and then found back at the original capture site in the spring. This would be supported by the high site fidelity of red drum recaptures in the SCDNR tagging programs, with an average distance moved of forty fish recaptured after 15+ years-at-large of 46 km (0.6 – 179 km; J. Ballenger, pers. comm.). In summer, fish moved up the Altamaha River 20 km to what the authors refer to as “pre-spawn staging areas” and then returned to the same shoal or beach again in the fall. Adult red drum inhabit high salinity surf zones along the coast and adjacent offshore waters, at full marine salinity. Adults in some areas of their range (e.g., IRL, FL) can reside in estuarine waters year-round, where salinities are variable.

### **3.3 Fish Habitat of Concern**

Fish habitat of concern (FHOC) designations for red drum were published by the ASMFC Habitat Committee in 2024 (ASMFC 2024) and are summarized herein. FHOC's varied based on life stage, with early juvenile FHOCs identified as protected marshes (tidal fresh, brackish, and salt water) and tidal creek habitat (Peters & McMichael 1987; Wenner 1992; FWCC 2008). While sub-adults use a wide range of estuary habitats, they exhibit the highest abundances and apparent productivity in association with submerged aquatic vegetation, oyster reef, tidal creeks, and marsh (tidally fresh, brackish, and salt) habitats (Pafford et al. 1990; Wenner 1992; Adams & Tremain 2000). FHOCs for adults include inlets, channels, sounds, outer bars, and within estuaries in some areas (e.g., Indian River Lagoon, FL) due to their importance for red drum spawning activity (Murphy & Taylor 1990; Johnson & Funicelli 1991; Reyier et al. 2011).

## **4 FISHERY-DEPENDENT DATA SOURCES**

Red drum fisheries are primarily recreational and, since the 1990s, exclusively so in the southern states (South Carolina, Georgia, Florida). Some commercial catch continues in northern states, but typically as bycatch in fisheries directed at other species. Fishery-dependent (FD) data are presented by fleet and stock designations. In the northern stock, most commercial and recreational catch comes from North Carolina waters, followed by Virginia, with low and variable catches north of Virginia. There have been similar regulation histories in North Carolina and Virginia, so northern stock fleets are aggregated catches from all states. There are two commercial fleets based on gear differences: a gill net and beach seine fleet (referred to as the North\_Commercial\_GNBS fleet in the assessment methods sections) and a fleet including catch from other commercial gears (primarily pound nets; referred to as the North\_Commercial\_Other fleet in the assessment methods sections). There is also a recreational fleet accounting for catch by recreational anglers using hook and line gear (referred to as the North\_Recreational fleet in the assessment methods sections). The three states in the southern stock have had different regulations through time and all regularly contribute to annual red drum catches. Past assessments have had time series starting after most of the commercial catch of red drum was phased out, so there are three recreational fleets accounting for catch by recreational anglers using hook and line gear in each of the three southern stock states (referred to as the SC\_Recreational, GA\_Recreational, and FL\_Recreational fleets in the assessment methods sections).

FD data sets considered during the assessment, but ultimately deemed not useful for deriving inputs for assessment approaches are described in Section 12.

### **4.1 Commercial Data**

#### **4.1.1 Data Collection and Treatment**

##### **4.1.1.1 Commercial Landings**

Historical commercial landings (1950 to present) for the Atlantic coast have been collected by state and federal agencies and are provided to the Atlantic Coastal Cooperative Statistics

Program (ACCSP) where they are maintained in the ACCSP Data Warehouse. The Data Warehouse was queried in May 2023 for all red drum landings (monthly summaries by state and gear category) from 1950 to 2022 for the east coast of Florida (Miami-Dade/Monroe County border), and all other Atlantic states. Gear categories were based on those used in SEDARs 18 and 44 and are based on knowledge of Atlantic coast red drum fisheries and reporting tendencies. The specific ACCSP gears included in each category can be found in Table 17. Landings from gear categories for the northern stock are aggregated into two groupings for presentation and use in this assessment based on expected similarities in selectivity among gears within each grouping and differences in selectivity between the two groupings. The first grouping includes the Beach Seine and Gill Nets SEDAR gear categories (North\_Commercial\_GNBS fleet) and the second grouping includes the Hook and Line, OTHER, Pound Net, Seine, and Trawls SEDAR gear categories (North\_Commercial\_Other fleet). Landings for the southern stock are aggregated by state, the structure of recreational fleets in this stock, for presentation and use in this assessment.

Landings data from ACCSP were reviewed and approved by state representative partners. In cases where discrepancies occurred, data directly from state databases was preferred to ACCSP Data Warehouse values. This included North Carolina data from 1994-2022 due to better gear allocation in NC trip ticket databases. Virginia harvester reports were used for 1993-2022 due to concerns on gear and area designations. New Jersey provided a custom data set for 2014-2022 containing catch used in direct sale from fishers. New York and Delaware both provided additional landing reports. Florida's commercial fishery ended in 1988, and between 1978 and 1988, reported gears are unreliable. Consistent with SEDAR 44, ACCSP staff extrapolated average gear proportions for Florida gears from 1962-1977 and applied those proportions to 1978-1988.

Preliminary commercial landings for the remainder of the 2022 fishing year that were not available during the original data query (January 2023-August 2023) were provided directly from state databases.

Landings data collection through time by states accounting for at least 1% of coastwide landings since 1950 are discussed below and are summarized for all Atlantic states in Figure 23 - Figure 26. A summary of the methodology used by individual states to obtain commercial landings data is available in Table 18, though more detailed information is provided in the following sections.

### Virginia

The National Marine Fisheries Service (NMFS) collected landings data for Virginia from 1950 through 1992. From 1973 to 1992, Virginia implemented a voluntary monthly inshore dealer reporting system, which was intended to supplement NMFS data. However, it was discovered that better inshore harvest data were required so the VMRC implemented a Mandatory Reporting Program (MRP) to collect Virginia commercial landings data that began January 1, 1993. The program currently is a complete census of all commercial inshore and offshore harvest in a daily format. Data collected are species type, date of harvest, species (unit and

amount), gear type, gear (amount and length), area fished, dealer, vessel (name and number), hours fished (man and gear), crew amount, and county landed.

In 2001, several fields listed above (gear length, man hours, vessel information: name and number, and crew amounts) were added to come in compliance with the ACCSP-identified critical data elements. Also, data collection gaps in the NMFS offshore collection program were identified and all offshore harvest that was not on a federally permitted species or sold to a federally permitted dealer was added to the MRP. The MRP reports are collected on daily trip tickets annually distributed to all commercially licensed harvesters and aquaculture product owners. All harvesters and product owners must report everything harvested and retained on the daily tickets. The daily tickets are put in monthly folders and submitted to VMRC. The monthly folders are provided by the VMRC and due by the 5<sup>th</sup> of the following month. Since 2022 these reports have also been made available to report electronically.

### North Carolina

The NMFS, prior to 1978, collected commercial landings data for North Carolina. Port agents would conduct monthly surveys of the state's major commercial seafood dealers to determine the commercial landings for the state. Starting in 1978, the NC DMF entered into a cooperative program with the NMFS to maintain the monthly surveys of North Carolina's major commercial seafood dealers and to obtain data from more dealers. The NC DMF Trip Ticket Program (NCTTP) began on 1 January 1994. The NCTTP was initiated due to a decrease in cooperation in reporting under the voluntary NMFS/North Carolina Cooperative Statistics Program in place prior to 1994, as well as an increase in demand for complete and accurate trip-level commercial harvest statistics by fisheries managers. The detailed data obtained through the NCTTP allows for the calculation of effort (i.e., trips, licenses, participants, vessels) in a fishery that was not available prior to 1994 and provides a much more detailed record of North Carolina's seafood harvest. Landings of red drum were calculated for North Carolina and reported in pounds (whole weight) broken down by month and gear categories used in past assessments. Data used to calculate the landings for North Carolina included landings from the NCTTP (1994 to 2023), landings from NMFS (1978 to 1993), and landings from historical data (prior to 1978). Prior to 1972, monthly landings were not recorded for North Carolina.

North Carolina also has landings from the recreational use of commercial gear allowed through the possession of a recreational commercial gear license (RCGL). This license allows for limited use of commercial gear to obtain fish for personal consumption. No sale is allowed with this license. Additionally, users must adhere to recreational bag limits. To estimate landings with this gear, North Carolina conducted a random survey of license holders from 2002 to 2007. Questionnaires were mailed to 30% of license holders each month. Information was obtained on locations fished, gears used, species kept and species discarded. A ratio of RCGL landings and commercial gillnet landings in overlapping years was used to estimate landings in years before and after the survey.

### South Carolina

Prior to 1972, commercial landings data were collected by federal fisheries agents based in South Carolina, either U.S. Fish and Wildlife Service or NMFS personnel. In 1972, South Carolina began collecting fishery landings data from coastal dealers in cooperation with federal agents using forms supplied by the SCDNR. These mandatory monthly landings reports were required from all licensed wholesale dealers in South Carolina. Until fall of 2003, those monthly reports were summaries collecting species, pounds landed, disposition (gutted or whole) and market category, gear type and area fished; since September 2003, landings have been reported by a mandatory trip ticket system collecting landings by species, disposition and market category, pounds landed, ex-vessel prices with associated effort data to include gear type and amount, time fished, area fished, vessel and fisherman information. Validation of landings is accomplished via dockside sampling.

At a minimum, South Carolina's trip-ticket program collects data on commercial effort, commercial catch, and economical value. Minimally, effort data includes gear types and quantity, location, and hours fished. Catch data includes species, disposition of catch, and quantity (pounds) landed. Finally economic data includes the wholesale price paid to fishermen.

Given commercial harvest of red drum has been prohibited in South Carolina since June 1987, the history of red drum landings in South Carolina are not very large particularly relative to other states, with the largest documented landings occurring the year the commercial fishery was shut down (14,689 pounds in 1987). Note, South Carolina has had some very small amount of reported illegal harvest (confidential) of red drum since their designation as a gamefish.

### Georgia

Prior to 1982, the NMFS and its predecessor agencies had been responsible for the collection of commercial fisheries landings data in Georgia. In 1982, with funding from NMFS, the Georgia Department of Natural Resources (GADNR) began collecting weekly and monthly commercial landings data from coastal Georgia. These included catch, area, effort, gear, value and associated data at various levels of detail depending on fishery and data needs. In 2001, Georgia implemented a trip ticket program in accordance with the minimum requirements set forth by the ACCSP partners. Additional data elements were added and the Georgia landings database was upgraded to meet the requirements. Trip level data are collected for all trips landing products in Georgia. Data collected include trip start and unloading dates, area fished, harvester and dealer, gear, species, market size, quantity, and value.

A small-scale gillnet fishery for red drum existed in the 1950s; however, the use of gillnets in Georgia's territorial waters was prohibited by statute in 1957. Since that time the commercial fishery for red drum was comprised predominately of hook and line recreational anglers and for-hire fishers that sell their catch. This catch was often sold directly to restaurants and not documented in commercial landings reporting. These landings are considered recreational (i.e., captured in the recreational catch survey – see Section 4.2.1) and all sale was restricted to the recreational bag limit. Red drum were granted game-fish status in 2013 thereby making commercial sale illegal.

## Florida

Commercial landings information was obtained from the FL FWC's Marine Fisheries Information System data and from the Fisheries Statistics Division of the NMFS for the years 1950 to 1988. No commercial landings have been reported for Florida since 1988 when the sale of native-caught red drum was prohibited.

Prior to 1986, landings of red drum were reported to the NMFS through monthly dealer reports made by major fish wholesalers in Florida. Since 1986, information on what is landed and by who in Florida's commercial fisheries comes from the FWC's Marine Resources Information System, commonly known as the trip-ticket program. Wholesale dealers are required to use trip tickets to report their purchase of saltwater products from commercial fishers. Conversely, commercial fishers must have Saltwater Products Licenses to sell saltwater products to licensed wholesale dealers. In addition, red drum became a "restricted species" in late 1987 so only fishers who had Restricted Species Endorsements on their Saltwater Products License qualified to sell red drum (though commercial fishing effectively ended shortly after this in 1989). Each trip ticket includes the Saltwater Products License number, the wholesale dealer license number, the date of the sale, the gear used, trip duration (time away from the dock), area fished, depth fished, number of traps or number of sets where applicable, species landed, quantity landed, and price paid per pound. During the early years of the program some data fields were deleted from the records, e.g., Saltwater Products License number for much of 1986, or were not collected, e.g., gear used was not a data field until about 1991.

The commercial fishery for red drum in Florida ended in 1989 when a 'no sale' provision was enacted into law.

### **4.1.1.2 Commercial Discards**

Currently, the only available data to describe commercial discards are from an observer program for the North Carolina estuarine gill net fishery for the period of 2004 to present. The North Carolina estuarine gill net fishery is presumed to be the primary culprit of commercial red drum discards in North Carolina as gill nets typically account for >90% of red drum commercial harvest. In previous assessments, discard estimates were calculated by area and season for both large and small mesh gill nets. Large mesh gill nets were defined as having a stretched mesh webbing of five inches or greater. CPUE was defined as the number (or weight) of dead red drum observed per trip. In addition, a release mortality (5%; consistent with SEDAR 18) was added for red drum released alive. Total gill net trips taken using estuarine gill nets in North Carolina (effort) were available through the NCTTP.

For the current assessment, discard estimates were estimated using a generalized linear model (GLM) framework to predict red drum discards in North Carolina's estuarine gill-net fishery based on data collected during 2004 through 2022 (Table 19). Available variables included mesh size, year, season and area; these were all treated as categorical variables in the model. Live and dead discards were modeled separately.



All available covariates were included in the initial model and assessed for significance using the appropriate statistical test. Non-significant covariates were removed using backwards selection to find the best-fitting predictive model. The offset term was included in the model to account for differences in fishing effort among observations (Crawley 2007; Zuur et al. 2009; Zuur et al. 2012). Using effort as an offset term in the model assumes that the number of red drum discards is proportional to fishing effort (A. Zuur, Highland Statistics Ltd., pers. comm.).

The best-fitting model was a negative binomial GLM that included mesh size, year, season and area as significant covariates for modeling both the live (dispersion = 3.2) and dead discards (dispersion = 1.9) in numbers (Figure 22). After estimates from 2004-2022 were calculated with the GLM framework, a hindcast approach using an average annual dead discard or live discard to gill net landings ratio calculated from 2004 through 2019 and 2021 through 2022 was applied to gill net landings from 1981-2003 to estimate discards consistent with the prior assessment. Estimates were not available in 2020 due to interruptions in sampling caused by the COVID-19 pandemic.

#### **4.1.1.3 Biological Sampling**

##### Virginia

Commercial length frequency data were obtained by the VMRC Biological Sampling Program (BSP). Red drum lengths and weights were collected at local fish houses by gear, area fished, and individual watermen.

Fish were measured for both TL and FL (mm) and individual weight (nearest 0.01 lb.). Typically in this program, otoliths, as well as sex and maturity data, are collected from a subsample of fish encountered. However, due to the infrequency of red drum encounters, sampling is more opportunistic and all fish encountered by technicians are sampled. Similarly, a subsample of collected age samples would be selected for full ageing, but all red drum otoliths are processed due to their typically small sample size.

Major commercial gears for Virginia are pound nets, anchored gill nets, and haul seines. Commercial samples were taken throughout the year and from all areas where red drum were landed. Fishery-dependent length frequency data collection for red drum in Virginia began in 1989. Red drum sampling events have remained infrequent throughout the program, but sampling does occur in a representative manner annually. Virginia has collected 2,818 length and 873 age samples since 1989, averaging 81 lengths and 25 ages on a yearly basis.

These data have been collected for a long time series but are limited in sample size in some years. Length data from this program were compared to North Carolina data and showed similar ranges in harvested fish due to the slot limits, with some slight differences in relative peaks within the slot sizes. These differences are likely driven by gear differences. However, the differences were not large enough to cause concern among the SAS. Due to the similarities, the complications of not having a complete time series of robust length sampling, and the small proportion of total removals accounted for by VA commercial landings, the SAS decided not to

use these length data and, instead, use the North Carolina data alone to characterize commercial size compositions for the northern stock. Age data were used for conditional age-at-length data in the SS model.

### North Carolina

Commercial length frequency data were obtained by the NCDMF commercial fisheries-dependent sampling program. Red drum lengths were collected at local fish houses by gear, market grade (not typical for red drum), and area fished.

Individual fish were measured (mm, FL) and total weight (0.1 kg) of all fish measured in aggregate was obtained. Subsequent to sampling a portion of the catch, the total weight of the catch by species and market grade was obtained for each trip, either by using the trip ticket weights or direct measurement. Length frequencies obtained from a sample were then expanded to the total catch using the total weights from the trip ticket. All expanded catches were then combined to describe a given commercial gear for a specified time period. Major commercial gears for North Carolina are gill net, long haul seine, and pound net. Commercial samples were taken throughout the year and from all areas where red drum were landed. Fishery-dependent length frequency data collection for red drum in North Carolina began in the early 1980s. Data adequate to describe the major fisheries is available beginning in 1989.

Since the late 1980s North Carolina has been the major commercial harvester of red drum, typically accounting for >90% of the coastwide annual commercial landings. Since 1989, greater than 100 lengths have been obtained annually with the majority coming from the primary gear used to harvest red drum, gill nets, followed by pound nets and haul seines (Table 20).

Lengths of discarded fish have also been recorded by observers during the observer program (Table 19). Number of lengths collected annually have ranged from 8 (2021 fishing year) to 1,838 (2012 fishing year).

#### **4.1.1.4 Catch Composition**

Length distributions for North Carolina commercial landings were derived from length data provided from commercial fish house sampling. All length distributions were described annually in two-centimeter length bins with the length bin provided representing the floor (i.e., 46 cm = 46.0 to 47.99 cm). A minimum of 20 lengths by year and gear were required to represent the length distribution of a gear. Collapsing, when necessary, occurred across gears within a year. Prior to 1989, sample sizes were sparse and were not considered adequate to describe the fishery. For this reason, the previous red drum assessment began with 1989 as the beginning year for all catch-at-age data. Since 1989, sampling was adequate for the vast majority of the landings (i.e., gill net landings in North Carolina) and pooling was limited to minor gears/landings (Table 20).

Conversion of North Carolina commercial landings in weight to numbers was based on mean weights obtained from the commercial fish house sampling. In the rare instance when sample

sizes were inadequate ( $n < 20$ ) by gear and year, a weighted average was obtained by pooling across gears within a year. For hook and line gears, mean weights from the recreational fishery (see Section 4.2.1) were used as a proxy. Landings in numbers are reported in Table 21.

#### **4.1.1.5 Catch Rates**

No useful trend information can be derived from commercial catch rate data. Trip level commercial data were available from North Carolina (1994 to 2022) and Virginia (1993 to 2022), however, catch effort data from the red drum commercial fishery were confounded by trip limits put into place in 1992 for Virginia and in 1998 for North Carolina. Trip level information was also available in Florida but only for the years 1986 to 1988. After 1988, the sale of native caught red drum in Florida became prohibited.

#### **4.1.2 Trends**

##### **4.1.2.1 Commercial Landings**

Commercial landings data are presented below in calendar year as monthly data were not available earlier in the time series, precluding presentation of historical commercial landings in the fishing year definition adopted in this assessment. Additional presentation of commercial landings in the fishing year definition during years when monthly data were available and covering the time series used in the assessment models is provided in Section 4.4.

##### *Northern Stock*

Northern stock red drum landings by the North\_Commercial\_GNBS fleet were primarily landed with beach seines in the 1950s and early 1960s (Figure 23). Total landings were high in the early 1950s, averaging 206,220 pounds from 1950-1954, then declined to the lowest levels of the time series in the late 1960s (minimum of 1,400 pounds in 1969). Landings then increase and transition to coming from mostly gill nets in the 1980s. Landings from the North\_Commercial\_GNBS fleet have varied without discernible trend since the 1980s, averaging 138,337 pounds from 1980-2022.

Northern stock red drum landings by the North\_Commercial\_Other fleet decline from the earliest years to low levels in the late 1960s (Figure 24). Landings then increased to higher levels in the 1970s and 1980s, averaging 77,932 pounds. Landings decline through the 1990s and remain at lower levels during recent years, averaging 17,064 pounds since 2000. Pound nets have accounted for a large proportion of the total landings throughout the time series, while trawls accounted for large proportions in the early 1950s and 1980s. Seines also accounted for a large proportion of landings from the 1960s through 1990s.

Estimated landings from RCGL gill nets in North Carolina ranged from a high of 24,750 pounds in 1999 to a low of 2,992 pounds in 1997 (Table 22). 2007 was the second highest estimate in the time series.

Overall, northern stock red drum landings were consistently high in the early 1950s, averaging 153,520 pounds from 1950-1954, then decreased through the 1960s to time series lows (minimum of 5,000 pounds in 1969, Figure 25). Landings increased through the 1970s and 1980s and have shown high interannual variability since, ranging from 58,951 pounds in 1997 to 408,021 pounds in 2013. The North\_Commercial\_GNBS fleet accounted for most of the commercial red drum landings in the northern stock in the beginning of the time series through the mid-1960s. The North\_Commercial\_Other fleet became a primary contributor to landings in the mid-1960s through the 1970s when seines accounted for a large proportion of this fleet's landings. Landings by the North\_Commercial\_Other fleet then decline and commercial landings have come primarily from the North\_Commercial\_GNBS fleet since the 1990s. The RCGL landings have accounted for ≈5% of landings (9,556 pounds), on average, since these data have been available (1989).

### Southern Stock

Southern stock red drum commercial landings were highest during the 1950s when all southern states made significant contributions to the landings, averaging 204,986 pounds from 1950-1956 (Figure 26). Landings then declined to low, stable levels and came mostly from Florida as South Carolina and Georgia made only minor contributions. Landings averaged 136,333 pounds from 1957-1984. During the mid-1980s, commercial fisheries faced tightening restrictions resulting in declining landings prior to being prohibited in South Carolina in 1987 and a moratorium in Florida in 1988. Commercial landings from the southern stock were, for the most part, phased out by 1989 when the Florida fishery was closed permanently.

Commercial landings from Florida in the 1980s were converted from pounds to number of fish during SEDAR 18 (Murphy 2009) and are presented in Table 23. Landings in numbers are highest in 1981 at just over eighty-seven thousand fish and decline throughout the 1980s until the fishery was closed permanently in 1989.

#### **4.1.2.2 Commercial Discards**

##### Northern Stock

Total commercial discards from North Carolina gill net fisheries have varied without any discernable trend throughout the time series (Figure 22). Total dead discards averaged 12,419 fish from 1981-2022 and ranged from 1,887 fish in 2010 to 38,948 fish in 2012 (Table 19).

#### **4.1.2.3 Catch Composition**

##### Northern Stock

Length distributions for North Carolina are presented by major gears in Table 24. For the length distributions, all gears showed a notable shift towards larger fish, particularly after 1991 when North Carolina implemented a minimum size limit change from 14 to 18 inches TL (Figure 27). Likewise, the harvest of larger red drum has declined as commercial sale of red drum >27 inches TL became illegal in 1992.

The majority of discarded lengths observed in the estuarine gill net fishery were from fish below the minimum size limit of 18 inches TL (approximately 44 cm FL) with some discards occurring within the slot likely due to exceeding the daily trip limit and fewer over the slot limit (Figure 29). Due to COVID-19 interruptions, lengths were not gathered in 2020 and collections were truncated in 2021.

#### **4.1.3 Potential Biases, Uncertainty, and Measures of Precision**

Collection of commercial landings data has been designed as a census to capture total landings, but methods to collect these data have changed through time leading to changes in uncertainty. There are no quantitative measures of uncertainty accompanying commercial landings data, but Table 18 shows changes to landings data collection methodology by state through time. Each methodology is anticipated to be an improvement to the data collection methodology that preceded it. Commercial landings data uncertainty was an issue addressed during a Best Practices Workshop convened by SEDAR (SEDAR 2015b). The recommendation produced from this workshop was to assume uncertainty decreases as the data collection methodology changes through time, resulting in time blocks of decreasing uncertainty levels from historic to current data collection methods.

## **4.2 Recreational**

### **4.2.1 Marine Recreational Information Program**

#### **4.2.1.1 Introduction and Methodology**

The primary source of red drum recreational catch data along the Atlantic coast is the Marine Recreational Information Program (MRIP). MRIP consists of three general surveys to estimate recreational catch, the Access Point Angler Intercept Survey (APAIS), the Fishing Effort Survey (FES), and the For-Hire Survey (FHS). The APAIS is a dockside survey where interviewers intercept anglers returning from fishing trips to collect information on catch and fishing area. Data are used to estimate species-specific catch rates by disposition, characterize the size structure and weight of fish harvested, and determine the proportion of fishing effort occurring in three general areas of marine waters (inland, state seas from the coastline out to three miles, and the federal EEZ beyond three miles from the coastline). Dispositions reported by anglers include harvested and either available for inspection (Type A catch) or unavailable for inspection (e.g., fileted at sea, Type B1 catch) and released alive (Type B2 catch). The FES is a mail-based survey that collects data on fishing effort by anglers from U.S. households fishing from shore and private/rental boats to estimate total fishing effort. The FHS is the counterpart to the FES that collects data on fishing effort by for-hire charter boat and headboat captains through a telephone survey. Each of these components of the MRIP survey have undergone design changes since 1981, with a brief description of survey design changes below. Interested readers who would like more details on the survey design changes are encouraged to review the resources available through the NMFS Office of Fisheries Statistics ([www.fisheries.noaa.gov/recreational-fishing-data/about-marine-recreational-information-program](http://www.fisheries.noaa.gov/recreational-fishing-data/about-marine-recreational-information-program)).

MRIP surveys implement a stratified sampling design, stratifying by state, year, wave (bimonthly period), and fishing mode (shore, private/rental boat, headboat, and charterboat). Catch rate data collected during the APAIS for each stratum are applied to total effort data from the FES and FHS to estimate total harvested catch (Type A+B1 catch) and total catch released alive (Type B2 catch). The area data collected during the APAIS are used for post-stratification of estimates by area.

Biological data collected during the APIAS sampling include FL and weight of Type A fish. Both are collected opportunistically but field interviewers are instructed to measure and weigh up to fifteen fish of each available species from each angler interviewed. The individual fish are to be selected from the total landed catch at random to avoid any size-bias in the resultant sample. These data are used to estimate harvest in weight and the size composition of harvested fish.

Two significant changes have occurred to the MRIP survey methodologies based on external reviews and recommendations throughout the duration of the program. The APAIS was redesigned in 2013 to improve the sampling design and the use of APIAS data in catch estimation methods. In 2018, the telephone-based effort survey used historically to collect effort data from U.S. households (Coastal Household Telephone Survey-CHTS) was replaced with the current mail-based FES. Since the last red drum stock assessment occurred before the effort survey change, historical estimates prior to 2013 used in that assessment were calibrated to correct for the APAIS redesign in 2013, but all estimates used in the previous assessment were based on CHTS effort data. MRIP now provides all historical estimates prior to 2018 with calibrations applied to correct for both the APIAS redesign changes and the transition to the mail-based FES and these calibrated data were first reported in the simulation assessment (ASMFC 2022). The FES results in increases in effort estimates and, therefore, total catch estimates relative to the CHTS.

Ongoing MRIP evaluations recently indicated potential overestimation of private/rental and shore fishing effort through a small-scale pilot study. These studies are currently being expanded, but effects to total private/rental and shore effort estimates, and therefore catch estimates, were not available in time for this assessment. See the MRIP website for more details on this development (<https://www.fisheries.noaa.gov/recreational-fishing-data/fishing-effort-survey-research-and-improvements>). Potential impacts from this development were investigated through sensitivity analysis in consultation with MRIP staff (Section 6.2.2).

#### **4.2.1.2 Trends**

##### **4.2.1.2.1 Total Catch**

Investigated herein were harvest, numbers released, dead discards, and total removals (harvest + dead discards) annually by fishing year. Data for the 2022 fishing year are preliminary. Dead discards, and subsequently total removals, were calculated based on an 8% discard mortality rate for recreationally captured and released red drum, consistent with SEDAR 18 and SEDAR 44.

## **Total Harvest**

### Northern Stock

Harvest from the northern stock was relatively high in the 1980s, decreased significantly in 1990, and remained at these lower levels through the mid-2000s (Table 25, Figure 30). Harvest then increased to higher levels through the remainder of the time series, including the three highest annual harvests during the time series (2013, 2016, and 2020). Interannual harvest is highly variable reflecting year class strength in this recruitment-based fishery.

Proportional standard error (PSE) for harvest estimates is higher in the 1980s, exceeding 40% in three years (Table 25, Figure 31). PSEs then decline and remain below 40%. Estimates with PSEs below 40% are considered valid inputs for stock assessment models, while estimates with values between 40% and 60% should be used with caution, and any estimates with PSEs >60% should be used with extreme caution (ACCSP 2016). Harvest estimates with confidence intervals are provided in Figure 32.

### Southern Stock

Patterns of harvest from states in the southern stock have been similar to the northern stock, with higher harvest early in the time series, lower harvest in the middle of the time series, and higher harvest in recent years (Table 26, Figure 33). Florida has accounted for the most harvest, followed by South Carolina and Georgia.

PSEs in southern stock states are generally higher in the 1980s and 1990s, then decline to lower levels since (Table 26, Figure 34). PSEs exceed 40% in several early years in South Carolina and Florida and exceed 60% in 1983 and 1981 in South Carolina and Georgia, respectively. Notably, there was an increase in PSE for Florida at the end of the time series, though values remained below 40%. Harvest estimates with confidence intervals are provided in Figure 35.

## **Total Discards**

### Northern Stock

Red drum released alive in the northern stock accounted for a smaller proportion of total catch in the 1980s, but then increased through the remainder of the time series and account for an increasing majority of total catch (Table 25, Figure 30). Assuming an 8% discard mortality due to catch, consistent with past stock assessments, dead discards account for a similar, though generally slightly lower, proportion of catch as the harvest since the early 2000s.

PSEs for discarded catch are high in the 1980s and regularly exceed 60% (Table 25, Figure 31). PSEs then decline to levels lower than 40% in the mid-1990s and become similar to PSEs for harvested catch through the remainder of the time series. Discard estimates with confidence intervals are provided in Figure 32.

### Southern Stock

Red drum released alive in the southern stock have also increased through the time series and become bigger components of the catch, though these changes have occurred differently in each of the states (Figure 30, Figure 33). Releases have regularly exceeded harvest since the mid-1980s in Florida, since the mid-1990s in South Carolina, and since the early 2000s in Georgia. As with harvested fish, Florida has accounted for the most followed by South Carolina and then Georgia. With the assumed 8% discard mortality, dead discards have yet to exceed harvested catch in any of the southern states as seen occasionally in the northern stock. However, annual dead discards still account for a significant proportion of annual total removals, averaging 37%, 18%, and 35% in South Carolina, Georgia, and Florida, respectively, during the last five years of the time series (2018-2022).

PSEs were high in South Carolina through the mid-1990s, exceeding 40% and 60% in several years (Figure 30, Figure 34). PSEs then decrease markedly and are typically lower than harvest PSEs since the mid-2000s. PSEs in Georgia were above 40% through 1984 with two years above 60%, decline to lower levels through the 1990s with only one year above 40% (1989), and decline further to values similar those for harvest estimates in years since the 1990s. PSEs for Florida discards are also high in the 1980s and early 1990s with several exceeding 40% and one exceeding 60%, then decline to low levels similar to harvest PSEs. Discard estimates with confidence intervals are provided in Figure 35.

## **Total Removals**

### Northern Stock

When harvest and dead discards are combined, removals from the northern stock initially decreased from highs in the mid- to late-1980s and remained low and stable through the mid-1990s (Figure 36). From these lows, total removals have steadily increased to all-time highs in recent years. There tend to be cyclical patterns with high removals occurring in two- to three-year periods.

Assuming PSEs for dead discard estimates are equal to PSEs for released alive estimates, PSEs for removals were higher in the 1980s, exceeding 40% in several years, decreased to levels around 20% in the early to mid-1990s, and decreased further in the late 1990s (Figure 37). There was an increase in the late 2010s, but PSEs have been below 40% every year since 1989.

### Southern Stock

When harvest and dead discards are combined, removals from the southern stock initially decreased in each state from highs in the early- to mid-1980s (Figure 38). Trends then differ by state. In South Carolina, total removals continue to decline through the 1990s, then increase through the 2000s and become stable at higher levels in the 2010s. Total removals generally increased since the 1980s in both Georgia and Florida, but at a greater rate in Florida. Removals in the late 2010s were at levels similar to the 1980s in all states. Removals are variable across states in the 2020s but were at lower levels than the 2010s in South Carolina and Florida.

PSEs in all states have decreased through time and have only exceeded 40% in a few years, primarily during the 1980s (Figure 39).



### **Imputed Wave 1 Catch Estimates**

MRIP has only consistently sampled anglers and generated catch estimates for wave 1 (January-February) in Florida waters. Some estimates were generated for Georgia in the 1980s, and estimates have been generated for North Carolina since 2006. No estimates have been generated for South Carolina, though the SCDNR State Finfish Survey (SFS) has sampled wave 1 catch with similar or identical protocols to MRIP (see Section 4.2.2). These estimates and supplementary data indicate there have been catches in wave 1 in these South Atlantic states, albeit generally lower catches relative to other waves throughout the year. To address this potential bias, catch estimates were imputed for states and years with no wave 1 catch estimates using disposition-specific (harvested vs. released alive) ratios of wave 1 to wave 2-6 catches in years when wave 1 catch information was available.

For North Carolina and Georgia, the medians of annual ratios of wave 1 to wave 2-6 MRIP catch estimates (Figure 40 and Figure 41) were applied to annual wave 2-6 MRIP catch estimates in years with no wave 1 catch estimates to impute catch estimates (Figure 42 and Figure 43). All available wave 1 catch information for Georgia was from the 1980s when fishing practices were different and highly skewed to harvesting. The median released alive ratio was 0 due to these low released alive catch estimates. Therefore, the median harvest ratio (0.04) was used for imputed released alive estimates to better capture fishing practices of more recent times. For South Carolina, the medians of annual ratios of wave 1 to wave 2-6 catch frequencies from the SCDNR SFS (Figure 44) were applied to annual wave 2-6 MRIP catch estimates in all years to impute catch estimates (Figure 45).

Magnitudes of imputed wave 1 catches are very small relative to overall annual catch and were generated with different methods than catch estimates provided by MRIP, so the SAS decided to use catch streams provided from MRIP without these imputed estimates as base data sets in assessment models. Imputed catch impacts were explored through sensitivity analysis.

#### **4.2.1.2.2 Catch Composition**

##### **Harvest**

##### *Northern Stock*

Annual length compositions for fish harvested from the northern stock are in Figure 46. When aggregated within regulation periods (Figure 47), length compositions show a shift to larger sizes in later years (>1991) as well as decreasing catches of larger fish protected by the slot limit.

The number of MRIP primary sampling units (PSUs), which is a unique interviewer assignment for sampling catch, with red drum encountered for length measurements are presented here along with the raw number of red drum measured for length. However, clustered sampling results in sample sizes less than the absolute number of individuals measured for size due to aggregations of like-sized individuals (Nelson 2014). Therefore, PSUs are used in the assessment as a proxy for length composition sampling replicates (i.e., precision), assuming a clustered sampling design (i.e., lack of independence).

The number of PSUs encountering red drum in the northern stock increased through the mid-1990s and has since varied without trend (Figure 48).

### Southern Stock

Annual length compositions for fish harvested from the southern stock states are in Figure 49, Figure 50, and Figure 51 for South Carolina, Georgia, and Florida, respectively. When aggregated within regulation periods (Figure 52-Figure 54), length compositions show regulatory-induced shifts such as narrowing slot limits.

PSUs in South Carolina and Georgia varied without much trend (Figure 55). PSUs in Florida increased to the highest levels in the 2000s and declined to lower levels in recent years.

### **Discards**

A primary data limitation in past red drum stock assessments has been the lack of data to describe the length and age composition of fish released alive in recreational fisheries. Because a portion of these fish are assumed to die due to interaction with the fishery (i.e., fishing mortality) and this component of the catch has become an increasingly large proportion of the total recreational catch, the lack of these data introduces a growing uncertainty in stock assessments. A number of supplementary data sources have been considered as proxy data sources including the state tagging programs (Section 4.3) and phone applications designed to collect voluntary data from anglers (iAngler- <http://angleractionfoundation.com/iangler> and MyFishCount - <https://www.myfishcount.com/>). These data sets were revisited during this assessment for consideration as proxy data sources.

The available phone application data sources provide limited data due to starting up more recently and growing their user bases, so efforts focused on tagging programs. Two data sets from these tagging programs were evaluated including sizes of fish tagged by volunteer anglers and sizes of tagged fish recaptured by anglers and subsequently released.

In the northern stock where all states' recreational fisheries have been combined into a single fleet in past stock assessments, there are tagging programs in Virginia and North Carolina. Historical North Carolina data (prior to 2014) were undergoing QA/QC procedures to align them with standards in place since 2014 and were not available for the assessment. Virginia data from the Virginia Game Fish Tagging Program (VGFTP) were available back to 2000. The North Carolina program employs both agency personnel and anglers to tag fish. Agency personnel tag all sizes caught during monitoring, but anglers have been instructed to only tag fish >27 inches since 2014 introducing a bias in the data set of sizes tagged by anglers. The VGFTP has not instructed anglers to tag particular sizes in any years highlighting the bias in the North Carolina data set and demonstrating better representation of sizes caught and released by anglers (Figure 56). Size compositions of tagged fish compared to MRIP harvest size compositions show the transition from releases to harvest in the management slot.

The data sets of tagged fish recaptured by anglers show smaller sizes recaptured and released by North Carolina anglers addressing the bias in the data set with fish tagged by anglers, but are limited in sample size and often noisy data sets. The noise can be seen in the comparison of

VGFTP data sets (Figure 57; e.g., early 2000s, 2015, 2017-2018) as well, but there are consistencies between data sets in years with better sample sizes of recaptured fish (e.g., late 2000s and early 2010s). The sizes of fish tagged by anglers show consistent modes prior to minimum legal size and for large bull red drum which is intuitive given the regulations in place (Figure 58). This also indicates volunteer anglers are still harvesting fish of legal size and their decision-making process while tagging is not biased towards practices of tagging and releasing all sizes caught including legal-sized fish. Based on these evaluations, the VGFTP data set of sizes of fish tagged by volunteer anglers represents the best proxy data set to use for fish released alive in the northern stock. Potential bias remaining in this data set includes providing size compositions not representative of the overall northern stock given these data don't come from the state that accounts for the majority of catch (North Carolina).

In the southern stock, there are tagging programs in South Carolina (Marine Game Fish Tagging Program, MGFTP, and fishery-independent tagging programs) and Georgia (Cooperative Angler Tagging Project, CATP). South Carolina employs agency personnel and volunteer anglers to tag fish and has large data sets but has provided varied instructions through time on sizes that should be tagged to anglers participating in the MGFTP. Anglers were instructed to only tag fish  $\geq 18$  inches from 1993-2010 and fish  $>10$  inches since 2020. Agency staff tagging covers more of the population size structure, but they have been instructed not to tag fish  $<250$  mm (9.8 inches) from 1992-1998 and 2002,  $<300$  mm (11.8 inches) from 1999-2001, and  $<350$  mm (13.8 inches) from 2003-2022, increasingly limiting representation of the smallest sizes. Early tagging data show capture of smaller sizes (both for tagging and in recaptures) before instructions to anglers participating in the MGFTP to limit tagging to sizes  $\geq 18$  inches in 1993 (Figure 59). These sizes are then phased out of the distributions indicating bias from tagging program instructions. Once these instructions were rescinded in 2011, the smaller sizes in the distribution below the slot limit phase back in (Figure 60). Anglers were instructed to tag fish  $\geq 10$  inches in 2020, but proportions for these sizes are negligible in earlier years and there is no clear impact to the size distributions from these instructions. Sizes of angler recaptures and subsequent releases show a slight bias in the smaller sizes as these fish are growing rapidly at these sizes and aren't showing up in recaptures until they've grown beyond the sizes first tagged, as well as potential bias from instructions to agency personnel in more recent years not to tag the smallest sizes.

Based on these evaluations the data set of sizes tagged by anglers from 1989-1992 and 2011-2021 represents the best proxy data set to use for fish released alive in South Carolina (Figure 61). However, a potential bias remaining in this data set is the paucity of larger, bull red drum despite a known catch and release fishery for these sized fish in South Carolina waters. This is due to anglers participating in the tagging program being biased towards those fishing inshore and not targeting bull red drum. This potential bias was discussed throughout the assessment and ultimately was considered too significant to use these data as a proxy data source in the stock assessment models. Representative size distribution data for fish released alive in South Carolina remains a major data limitation for the assessment.

The Georgia tagging program also relies on agency personnel and volunteer anglers to tag red drum. The program instructed anglers to only tag red drum  $\geq 16$  inches prior to 2011. The

impact of these instructions can be seen in both the limited tagging and recapture data sets (Figure 62). Beginning in 2019, program administrators encouraged tagging of sub-legal sized fish as well as all other sizes. The impact of these instructions is reflected in size distributions when sub-legal sized fish not seen in previous years show up in the distributions. A similar slight bias in recaptures subsequently released as seen in South Carolina data shows up in recent years of Georgia data due to rapid growth of the smallest sizes (e.g., 2020). Based on these evaluations, the data set of sizes tagged by anglers from 2018-2021 represents the best proxy data set to use for fish released alive in Georgia (Figure 63).

No tagging data are available from Florida and Florida state specific red drum assessments have used the phone application-based iAngler data as proxy release size compositions, so these data were used for this purpose in this assessment as well. The data are limited but do represent sub-legal sized fish and infrequent captures of fish larger than the maximum legal size (Figure 64).

In general, the tagging data from volunteer anglers were the best proxy data sets for states that had tagging programs. These data are not affected by time-varying effort like recaptures of fish subsequently released that were likely tagged across multiple years, some of which may have occurred under varying tagging instructions from the tagging program. These data sets typically have the largest samples sizes as well. It is assumed that volunteer anglers participating in tagging are representative of the general angling population and provide a representative sample of sizes available to anglers that get released (i.e., choice to tag is akin to choice of other anglers to release and not harvest), with the exception noted for South Carolina data.

#### **4.2.2 Supplemental Recreational Sampling**

There are several recreational fishery monitoring efforts by state agencies conducted aside from the general MRIP survey. The primary use of these efforts in past stock assessments has been to provide supplemental age-length key data for generating age composition data, as they were during this assessment.

##### **Virginia**

Since 2007, the VMRC has operated a recreational carcass recovery program known as the Marine Sportfish Collection Project. The goal has been to supplement the Biological Sampling Program with species that are traditionally scarce in the commercial sector and to characterize VA's recreational fishing activity. Chest freezers are established near fish cleaning stations at a rotating series of marinas and boat ramps in the Chesapeake Bay region, depending on seasonality and freezer availability. Each freezer is marked with an identifying sign and a list of target fish species. Cooperating anglers place the filleted carcasses, with head and tail intact, in a bag, drop in a completed donation form, and then place the bag in the freezer. Each fish is identified to species, the fish length is measured, sex is determined when possible, and the otoliths are removed. These otoliths are incorporated into the subsampling scheme of VMRC's ageing lab, with their original recreational status recorded for later reference.

The number of red drum collected by the Marine Sportfish Collection Project has traditionally been low, with notable peaks in 2009 (n=73) and 2013 (n=79) with 530 samples recovered since 2007. These fish ranged in size from 405-1146 mm TL with an average of 558 mm TL.

### **North Carolina**

In 2014, the NCDMF initiated a formal Carcass Collection Program. The objective of the project is to develop a statewide freezer collection program to obtain fishery-dependent length, sex and age samples of recreationally important fish. Since the beginning of the program, the NCDMF has maintained eight operational freezer sites where carcass collection occurs. Sites include tackle stores, fishing piers, shore access points and local NCDMF offices. NCDMF staff make scheduled checks of freezers to collect carcasses and resupply freezers with collection bags and information cards. Fish samples collected from the freezers are processed and entered into the NCDMF biological database. Information collected includes species of fish, length of fish, sex, otoliths for aging and catch information (fishing mode, date, location etc.). Samples of red drum collected annually have ranged from 20 (2015 Fishing Year) to 149 (2022 Fishing Year) with 708 collected from 2015 to 2022. Most red drum collected in the carcass collection program are age-1 and age-2 with some age-3 fish. This range of ages is consistent with the size of fish that can be legally harvested in the 18-to-27-inch slot limit.

### **South Carolina**

#### *Inshore Fisheries-Dependent Biological Sampling Programs*

Given the limited information on the size and age of recreationally harvested fish from South Carolina waters, the SCDNR Inshore Fisheries Research Section conducts two fishery-dependent biological sampling programs, namely a fishery-dependent freezer fish program and a fishery-dependent tournament sampling program. Both are designed to collect biological information on the size, age, and sex composition of recreationally harvested priority species. Red drum are included as a priority species of interest for both programs.

#### *Freezer Fish Program*

Since 1995, Inshore Fisheries has operated a freezer drop off program for recreationally important inshore finfish, enabling fish collection from areas and habitats not always represented in SCDNR monthly field sampling. Chest freezers are located near collaborating marinas, landings, or bait shops along the South Carolina coast. Participating anglers place the filleted rack with head and tail intact in one of the provided bags, drop in the completed catch information card, and deposit the bag in the freezer. Freezers are checked periodically by SCDNR staff and provided fish racks are brought back to SCDNR facilities for processing. Once in the lab, fish are identified to species, lengths are recorded, sex and maturity status are determined when possible, genetic samples are collected, and otoliths are removed. Otoliths are aged annually with each recreational capture day considered an independent collection event.

The number of red drum collected by the Inshore Freezer Fish Program is relatively low (Table 27) with the bulk of collections occurring from 1995 to 2003 (n = 1,412). Collections have

declined further in recent years with ranges from 100 in 2007 to 0 in 2021, with an average of 46 collected annually from 2004 to 2022. Historically, 2,283 have been processed by staff since the program began ranging in size from 343-810 mm TL with an average of 484 mm TL.

### Tournament Program

Inshore Fisheries began participating in Recreational Angler tournaments in 1986. Inshore staff act as weigh master at tournaments and collect biological samples from fish of participating anglers. Similar to the freezer fish program, fish are identified to species, lengths are recorded, sex and maturity status are determined through gross and histological sampling, genetic samples are collected, and otoliths are removed.

Since 1986, 1,023 red drum have been sampled at tournaments (Table 27) with a minimum size of 277 mm TL and a maximum size of 1,150 mm TL. Average size is 552 mm TL.

### State Finfish Survey

Implemented in 1988, the State Finfish Survey (SFS) was designed to address specific data gaps, within the Marine Recreational Fisheries Statistics Survey (MRFSS; precursor to MRIP), as identified by SCDNR staff. These data gaps included the lack of length data from species of concern to the SCDNR and the lack of seasonal and area-specific catch frequencies. Another concern was the lack of catch and effort data from private boat anglers, which make up a majority of the angling trips in South Carolina coastal waters. These data gaps were initially addressed by interviewing inshore anglers targeting red drum and spotted seatrout at specific sample locations. Beginning in 2002, more emphasis was placed on acquiring length data from all finfish retained by anglers, canvassing at additional sampling locations, and interviewing all private fishing boats within all South Carolina coastal areas. Broadening the scope of the survey may decrease some of the bias associated with the previous SFS protocol.

Sampling is conducted at public and selected private (with owner's permission) boat landings from January through December using a questionnaire and interview protocols similar to those implemented through the MRFSS. However, the SFS questionnaire focuses on vessel surveys rather than individual angler surveys and primarily targets private boats. Interviews are obtained from cooperative anglers at each sampling site. If an angler is unwilling to participate, they can decline to be interviewed. Assigned creel clerks interview as many anglers as time allows at any given site.

The sampling schedule is determined by "needs assessments" of the SCDNR Marine Resources Division and creel clerks. Individual creel clerks are assigned to a sampling region and will determine their daily sampling schedules based on local conditions (i.e., weather, landing closures, or events), additional job duties, and research and management initiatives. Attempts are made to assess all sampling sites equally, and individual creel clerks randomly rotate between sampling locations within their region. Creel clerks will remain at landings with fishing activity. If landings have little or no fishing activity creel clerks will move on to alternative sampling locations in close proximity.

The SFS uses a questionnaire and interview protocol similar to MRFSS/MRIP, with the same staff conducting both surveys since 2013. Data collected for the SFS questionnaire include:

1. Mode fished (i.e., private, charter, shore)
2. Specific body of water fished
3. Area fished (inshore, 0-3 miles, > 3 miles)
4. Utilization of artificial reef/reef name
5. Resident county of boat owner
6. Species targeted
7. Number of anglers participating on the vessel
8. Amount of time spent fishing for the trip
9. Expense of the trip (all anglers)
10. Angling trips the previous year, average of all anglers participating
11. Catch and disposition by species (includes both landed and released fish)
12. Length measurements obtained, with anglers' permission, for retained species; 1988 – March 2009: length measurements mid-line length (ML); April 2009 – present: length measurements (TL)

Intercept data are coded and key entered into an existing Access database. Queries are used to look for and correct anomalous data and a component of the database records are checked against the raw intercept forms.

For the period January 1988 through February 2013, data are available from each month of the year. Beginning in 2013, SFS staff took on the duty of conducting the MRIP survey in SC and as a result the traditional SFS survey only operates during the months of January and February (no MRIP sampling during this period). Given this, traditional SFS data from March-December is generally included in MRIP landings reported for South Carolina since 2013.

The SFS collects information on both the nature of individual fishing trips and biological information on the species captured during the trip from cooperating anglers. Trip level information includes the date, location (intercept site, fishing location, and locale (estuarine, nearshore, offshore), fishing mode (private, shore, charter, etc.), purpose of the trip, target (primary and secondary) species, and angler information such as the number of anglers, hours fished, and average number of trips during the previous year across anglers in the party. Recorded biological information includes the species caught and the number and dispositions of caught fish. For those fish harvested, length information is verified for creel clerks and provide an analogous data set to that obtained from the harvested fish encountered by the MRFSS/MRIP APAIS. For released fish, the creel clerks obtain information on the number of legal sized fish released and the number of illegal (i.e., outside the slot limit for red drum) fish releases as well as obtain self-reported size information from the anglers on these released fish.

From 1988 through 2022, the SFS conducted 73,657 interviews, with red drum being caught in 8,643 interviews, or approximately 12% of all trips. These red drum positive trips reported the capture of 40,100 fish (landed and released), with 11,787 (~29%) harvested and 28,313 (~71%)

released. The survey obtained length information from 11,487 fish (11,309 harvested fish; 178 released fish).

The nature of this survey suggests at least four potential uses in red drum stock assessments. Specifically, it provides the only source of fishery-dependent information related to the harvest and relative abundance of red drum in South Carolina waters during wave 1 (January and February). This leads to its second potential use, as a means to impute wave 1 catch and discard of red drum in South Carolina (Figure 65), as was done in Section 4.2.1. Third, due to the acquisition of length information, the survey provides information on recreational length compositions. A final use of this dataset could be to understand temporal changes in fisherman behavior relative to fishing practices, locations, within year timing of fishing, etc. which could become important to defining selectivity blocks. For example, the survey provides another source of information suggesting an increase in catch-and-release fishing throughout coastal South Carolina (Figure 66).

### **Georgia**

In the fall of 1997, the Georgia Department of Natural Resources (DNR) initiated the Marine Sportfish Carcass Recovery Project. This project takes advantage of the fishing efforts of hundreds of anglers by turning filleted fish carcasses that anglers would normally discard into a source of needed data on Georgia's marine sportfish. Chest freezers are placed near the fish cleaning stations at 20 locations along coastal Georgia. Each freezer is marked with an identifying sign and a list of target fish species. Cooperating anglers place the filleted carcasses, with head and tail intact, in a bag, drop in a completed angler information card, and then place the bag in the freezer. Each fish is identified to species, the fish length is measured, sex is determined when possible, and the otoliths are removed. A subsample of otoliths is aged annually. Each day is considered an independent sampling event. Red drum recovered through this program are typically within the slot limit of 14"-23" and mostly consists of individuals aged 0 to 2 years old.

The number of red drum collected by the Carcass Recovery Project ranged from 229 in 2006 to 1,336 in 2010 with an average of 628 fish collected each year. Staff have processed 16,346 red drum since the project began. These fish ranged in size from 225-950 mm FL with an average of 406 mm FL.

## **4.3 Tagging Programs**

### **Virginia Game Fish Tagging Program**

Since 1995, the VGFTP has tagged recreationally important finfish with the help of volunteer anglers. A cooperative effort between the Marine Advisory Program at the Virginia Institute of Marine Science (VIMS) and Saltwater Tournament at the VMRC, the program's funding is from state saltwater license funds and VIMS.

The number of cooperating anglers has changed from year to year and does not correlate with the number of fish that will be tagged each year. From 1995 through 2021, approximately 250 rotating anglers have tagged and released 64,871 red drum, peaking in 2012 with 18,461 tags.



In recent years the number of red drum tags deployed by the VGFTP has decreased from a period of high volumes of tags between 2005 and 2013. Tag returns have remained mostly stable throughout the lifetime of the survey, with an average return of 9% in the first year, but spikes have occurred periodically, most recently in 2014, with 11% recaptured in the first year (341 fish recaptured out of 3,028 tagged fish).

Anglers in the program have tagged primarily sub-legal fish, with the average TL being 16.9", below the 18"-26" slot limit in VA. Early in the program, larger fish were targeted to some degree, with the max recorded TL at 58".

### **North Carolina**

The NCDMF has conducted a tagging study on red drum since 1983. Tagging has been conducted using a variety of means and methods. The NCDMF has conducted directed and opportunistic tagging with trained NCDMF staff since 1983, in addition to trained anglers. During this period, anglers have tagged red drum primarily with large stainless-steel dart tags inserted in the muscle of the fish near the middle of the dorsal fin. Due to the large tag size, volunteer taggers were instructed to tag only large red drum (primarily greater than 685 mm TL) while NCDMF tagging efforts have focused on tagging sub-adult red drum (<685 mm TL) using primarily internal anchor belly tags.

The number of cooperating anglers has changed from year to year and does not correlate with the number of fish tagged each year. Over the entire period, 92 taggers have participated in the red drum tagging program. Typically, most fish are tagged by a small subset of taggers who are commonly fishing guides. Prior to 2004, less than 15 anglers participated annually tagging approximately 600 fish per year. From 2004 to 2019, an average of 22 anglers tagged 1,064 red drum per year with a high of 1,742 tagged in 2006. Participation in the volunteer tagging program has declined in recent years with 12 taggers tagging 245 red drum in 2019. This decline in numbers tagged has been driven by some attrition of traditional high-volume taggers. In 2020 and 2021, volunteer tagger participation remained low because of impacts related to the COVID-19 pandemic. During these two years, 15 taggers put in effort to tag 302 red drum. These declining numbers in both volunteer tagger participation and tagged red drum prompted the Multi-Species Tagging Program to begin recruiting new volunteers and re-engaging with former volunteers who stopped tagging for a variety of reasons. In 2022 and 2023, the tagging program added 30 new volunteer taggers and saw participation rates increase to 28 volunteers actively tagging—10 former volunteers and 18 new volunteers—who tagged 418 red drum total for the two-year period.

The angler tagging program combined with tagging from NCDMF staff has resulted in more than 80,000 red drum being tagged from 1983 to 2022. Since 1991, greater than 1,000 red drum have been tagged annually. Volunteer anglers accounted for approximately 35,000 of these tagged fish. Tagging program guidelines for volunteer anglers has changed throughout the time series with the most recent rule, 1999-present, to only tag red drum >27" TL with stainless steel dart low-reward tags. NCDMF staff have tagged red drum <27" TL with internal anchor high and low reward tags and >27" TL with stainless-steel dart low reward tags throughout the time

series. Recent volunteer tagged red drum averaged 37"TL from recreational anglers. Recent NCDMF tagged red drum averaged 18"TL with a range from 8" to 50"TL. Over the time series, the return rate across tag types and taggers has been approximately 11%. Recapture rates vary based on size of fish at tagging and the tag type used.

### **South Carolina**

The SCDNR has a long history of supporting conventional tagging programs with the primary goal of providing a forum for angler outreach and a mechanism for developing a conscientious angling public who know and utilize best fishing practices. In addition, the conventional tagging program is a platform used for the collection of valuable information on fish populations, including information on movement and migration, gear selectivity, and exploitation rates. To this end, SCDNR employs two complimentary tagging programs, the South Carolina Marine Game Fish Tagging Program (MGFTP) and the Inshore Fisheries Fishery-Independent tagging program.

#### *Marine Game Fish Tagging Program*

The MGFTP began in 1975 and was the first state-sponsored public tagging program on the East Coast. The program was initiated with a small contribution from the Charleston-based South Carolina Saltwater Sportfishing Association. Today, the program receives funding from the U.S. Fish and Wildlife Service's Sport Fish Restoration Act and South Carolina Saltwater Recreational Fishing License Funds. The tagging program has proven to be a useful tool for promoting the conservation of marine game fish and increasing public resource awareness with >19,000 participants having participated in the program including over 150 active taggers in 2022. In addition, the program has provided biologists with valuable data on movement and migration rates between stocks, growth rates, habitat utilization, and mortality associated with both fishing and natural events. The first red drum tagged via this program was released in 1978.

The MGFTP covers the entire coast of South Carolina. Most of the tag and recapture events occur inshore, leading to a bias towards tagging sub-adult red drum available in estuarine waters, but the program does collect data from nearshore and offshore sites. Data collected by the program includes tag number, date, species, length, length type, location, condition of fish upon release, and disposition of catch (in the case of a recapture).

The survey has directed its cooperative recreational anglers who are tagging red drum to target different size classes of red drum through time (Table 28). Currently anglers are requested to only tag red drum greater than 10 inches (254 mm) TL and that they only tag one red drum per "school" per day when fishing inshore waters. Further, they are requested to tag different sized red drum with different types of tags, using a T-bar tag for any fish less than 27 inches TL and a nylon dart tag for fish 27 inches TL or greater.

Since its inception, the MGFTP has deployed 96,626 red drum tags and 14,807 recaptures have been reported. Of these recaptures, 73% were reported as being re-released. Peak red drum tag deployment occurred in 2017, 2018, and 2019 (4,596, 6,863 and 6,446 respectively). In more recent years, limitations were put on how many red drum a single volunteer could tag per

day. This effort was put in place to allow for a greater number of program participants. During 2020 and 2021, combined anglers deployed 4,985 tags.

### *Inshore Tagging Program*

Since 1986, the Inshore Fisheries Research section of the SCDNR Marine Resources Research Institute (MRRRI) have tagged red drum captured during research and survey sampling. As such, we have tagged most released red drum captured by our sub-adult (stop net, trammel net, and electrofishing surveys; 1986-present) and adult (historic and contemporary longline surveys; 1994-present) fishery-independent surveys. In addition, red drum have been tagged through a number of specific research projects (tag reporting rate studies; tagging of red drum outside of SC, etc.). For this program, fish are measured and tagged with either an internal anchor “belly” or stainless steel anchor “shoulder” dart tag, based on size, before being released at their site of capture (Figure 67). Released fish larger than 550 mm TL are tagged using the shoulder tag, with all released red drum between 350 and 550 mm TL tagged using the belly tag. Data collected at tagging include collection level information retained as part of the survey (e.g., water quality, location (site, stratum, latitude/longitude), date, etc.), fish length (nearest mm SL and TL), and disposition (released with tag). As all released red drum not previously recaptured greater than 350 mm TL are tagged, this program exhibits a spatial footprint as large as the widest footprint of our fishery-independent surveys, resulting in the tagging of red drum across all five South Carolina estuaries and in both estuarine and coastal waters.

Regardless of source, the desired information on angler recaptures of tagged fish remains the same. Anglers are asked to report their contact information (full name, mailing address, and telephone number), the species of fish caught, the tag number, the date and location of the recapture, and the length and disposition of the fish (was the fish retained or released, and if released, was the tag removed or left on the fish). Each angler is offered a reward of either a t-shirt, printed to commemorate their catch, or a cap, with an embroidered logo. For each recapture, a report is mailed to the angler with information on the fish that they caught, including when and where it was originally tagged and its length at that time, how long the fish was at large, a minimum distance it traveled, and any other recaptures that have been reported for the fish, including project recaptures that may have occurred during inshore fishery-independent sampling. A cover letter is sent to each angler, with recent statistics on the numbers of fish tagged by the program and contact information for questions or reporting future recaptures.

Since its inception, the Inshore Tagging Program has tagged 75,413 red drum and obtained 31,699 red drum recaptures.

### *Combined SCDNR Tagging Program Data*

Since 1978, across programs the SCDNR conventional tagging programs has tagged 172,087 red drum through 2022 (Figure 68), with 46,506 recaptures (Figure 69). Based on disposition, the conventional tagging data suggests catch-and-release rates of red drum in South Carolina has

increased through time, with series lows in the late-1980s when the release rate was less than 25% to release rates in excess of 75% every year since 2000 (Figure 70).

Days at large of recaptures has varied greatly, from as short as the same day to as long as 8,403 days-at-liberty (Figure 71), with 11,576 recaptures of red drum at large at least 1 year since tagging (Table 29). The longest-at-liberty was a fish originally tagged via the SCDNR trammel net survey on 11/9/1992 when it was 580 mm TL. This individual was recaptured by an angler on 11/12/2015 in the Cooper River with a length of 1067 mm TL.

Based on location information, we can also infer information about minimum straight-line distance moved based on time-at-large for red drum based on this conventional tagging program (Figure 5). While the maximum minimum straight line distance moved was 467 km observed for a fish at-large for 739 days, only 28 fish moved >250 km with these 28 fish having days-at-large of 33-739 days. Only 0.6% of all recaptures (n = 272) occurred out of the state of South Carolina.

As part of the SCDNR tagging program, data is collected on the lengths of red drum encountered by recreational anglers across the state of South Carolina. This includes both the length at initial tagging (MGFTP only) and length at recapture by recreational anglers (MGFTP and FI tagging program). Coupled with disposition information (harvest vs. released), this provides a robust data set for investigation of harvest and release length compositions across coastal South Carolina. However, there are several caveats regarding the use of these data, including the self-reported nature of recreational length data and the biased distribution of lengths of tagged fish in the population.

## **Georgia**

Georgia's Cooperative Angler Tagging Project (CATP) began in 1987 and was created to involve anglers in tagging adult red drum as part of in-house research on the species. Tagging has proven to be a useful tool for promoting fish conservation as well as collecting valuable data on movement and migration, growth rates, habitat preference, and post-release survival. Partnering with recreational anglers is an efficient and cost-effective way for researchers to collect fisheries data and often creates a sense of ownership towards fisheries management decisions.

The number of cooperating anglers has changed from year to year and does not correlate with the number of fish that will be tagged each year. The number and species of fish tagged has varied over time as research objectives and staff have changed. From 1987 through 2022, approximately 250 cooperating anglers tagged and released over 6,000 red drum. In recent years the number of red drum tags deployed by the CATP has increased. Since 2017, 6,408 tags have been released, between 850-1,323 annually. Tag returns have also increased, with 1,243 total recaptured during the period.

Historically, cooperative tagging anglers tended to tag larger red drum, with a bimodal distribution of fish at the upper end and above the slot. The addition of staff tagging in 2020 improved tag coverage of red drum below and at the lower end of the slot. The mean FL of red

drum tagged by cooperative anglers was 600 mm, while the mean FL was 382 mm for staff tagging.

#### **4.4 Total Fishery Removals**

Aggregated northern stock removals are presented in units used in the assessment models, metric tons for commercial landings and numbers for all other sources (Figure 72). Commercial landings have been steady to decreasing, with a high degree of interannual variability, throughout the assessment period. Landings peaked in the late-1990s at a 3-year average of 144 mt (1997-1999) though a 3-year minimum of 39 mt annually was observed only a few years later (2001-2003). From 2019-2021, annual landings were 78 mt. Commercial dead discard account for small proportions of removals. Since peaking in the late-1990s (3-year average of 0.10 million fish (1997-1998)), discards have declined, with a 3-year average of 5,625 dead discards from 2019-2022.

Recreational removals exhibited a decrease in the early-1990s, with 3-year average annual removals declining from 0.39 million fish (1986-1988) to 0.12 million fish (1994-1996), before beginning to increase again in the late-1990s. Northern stock recreational removals have exceeded removals observed in the late-1980s since the late-2000s, peaking at 1.06 million fish removed annually from 2011-2013. In the terminal 3-years (2019-2021), annual recreational removals were 0.92 million fish. The recreational fishery accounts for an increasing proportion of northern stock removals through time, accounting for greater than 90% of annual removals over the last ten years. These removals are increasingly represented by dead discards, averaging 37% of annual recreational removals over the last ten years.

All southern stock removals are used in assessment models in numbers. Southern stock fishery removal numbers aggregated among all sources show a decline from high levels during the late 1980s, a slow and steady increase through the 2000s, and an increase at an accelerated rate in the 2010s (Figure 73). Removals in the late 2010s are similar to levels in the early to mid-1980s, averaging 2,231,459 fish per year from 2015-2019. There was a decline in removals in recent years, but levels remain high. Generally, Florida accounts for the largest proportion of removals through time, followed by South Carolina, and Georgia. These contributions have been relatively consistent since 2000, averaging 22%, 19%, and 59% contributions, on average, by South Carolina, Georgia, and Florida, respectively. The most notable divergence was the large proportion of removals accounted for by Georgia in the final year of the time series (2022). Recreational dead discards accounted for very small proportions of the total removals in the early 1980s (<3%), but accounted for an increasing proportion of total removals through the mid-2000s. Dead discards accounted for a relatively consistent proportion of total removals from 2005 through 2018, averaging 27% of annual total removals. Dead discard contributions then increased again in the final five years of the time series, averaging 31% of annual removals, with state specific dead discards representing 37%, 18%, and 35% of removals in South Carolina, Georgia, and Florida, respectively.

## **5 FISHERY-INDEPENDENT DATA SOURCES**

Twelve fishery-independent surveys have been used in past red drum stock assessments or the simulation assessment to provide indices of relative abundance. Three surveys monitoring the northern stock have been used including one indexing recruitment, one indexing primarily sub-adult abundance, and one indexing mature abundance. Nine surveys monitoring the southern stock have been used including three indexing recruitment, three indexing primarily sub-adult abundance, and three indexing mature abundance. Indices of relative abundance and associated composition data were generated from these twelve surveys for use in this assessment. One additional survey monitoring the southern stock, the South Carolina Electrofishing Survey, was also considered in this assessment as an additional measure of sub-adult abundance. The nomenclature included in parentheses next to each full survey name in the following section is used when referring to them in the assessment methods sections (Sections 6-8).

### **5.1 North Carolina Bag Seine Survey (NC\_BagSeine)**

#### **5.1.1 Data Collection and Treatment**

A red drum bag-seine survey offers complete survey coverage of 120 seine sets per year. Only in 1994 and 1999 did the number of seine sets fall below 100.

##### **5.1.1.1 Survey Methods**

The survey was conducted at 21 fixed sampling sites throughout coastal North Carolina (Figure 74) during September through November each year from 1991 through 2022. Each of these sites was sampled in approximately two-week intervals for a total of six samples with an 18.3 m (60 ft) x 1.8 m (6 ft) beach seine with 3.2 mm (1/8 in) mesh in the 1.8 m x 1.8 m bag. One “quarter sweep” pull was made at each location. This was done by stationing one end of the net onshore and stretching it perpendicularly as far out as water depth allowed. The deep end was brought ashore in the direction of the tide or current, resulting in the sweep of a quarter circle quadrant. Salinity (ppt), water temperature (°C), tidal state or water level, and presence of aquatic vegetation were recorded. Locations of fixed stations were determined in 1990 based on previous catch rates and practicality for beach seining (Ross and Stevens 1992).

##### **5.1.1.2 Biological Sampling**

All red drum were identified, counted, and measured to the nearest mm FL.

##### **5.1.1.3 Catch Estimation Methods**

The size distribution of red drum caught during this survey indicated most fish were age-0. Given this, a size cutoff for age-0 was set at 100 mm FL and only fish <100 mm FL (i.e., age-0) were used in the index. The 100 mm cutoff was sufficiently bigger than the largest age-0 and smaller than any observed age-1 fish collected during the sample period.

Seven stations were not sampled throughout the entire period of the survey, so they were removed from further analysis. The juvenile index was developed using a generalized linear model (GLM), with Poisson and negative binomial error distributions considered. The models were examined for best fit using dispersions (Zuur et al. 2009) and Akaike's Information Criterion (AIC; Akaike 1974). The best fit model was developed using a negative binomial error distribution with year and station as covariates (Poisson: AIC= 43,751, df=47, dispersion= 22.0; negative binomial AIC=14,092, df=48, dispersion=1.4).

### **5.1.2 Trends**

Catch rates were variable early in the survey with apparent strong year classes in 1991 and 1993 (Table 30, Figure 75). During 1999-2001 there was a consistent series of low annual catch rates followed by an increase through 2005, before another decrease from 2006-2009. A small increase occurred in 2011, but catch rates immediately decreased and remained low through 2014. Values have been increasing and variable through 2021 with an apparent strong recent year class in 2018.

### **5.1.3 Potential Biases, Uncertainty, and Measures of Precision**

The estimated standard errors for the standardized relative abundance were fairly consistent throughout the time period and ranged from 0.20 to 0.24. Hurricanes during 1996 caused extreme high and low water conditions and may have altered survey results. For this reason, it was recommended that the 1996 data point be deleted from the index.

## **5.2 North Carolina Independent Gill Net Surveys (NC\_GillNet)**

### **5.2.1 Data Collection and Treatment**

The NCDMF annually conducts a fishery-independent gill net survey in the Pamlico Sound and its tributaries, where it regularly encounters sub-adult red drum. This stratified-random gill net survey was designed to provide fishery-independent relative abundance indices for key estuarine species including red drum. Surveys in all regions use a stratified-random design. Strata are defined based on area and depth (greater or less than six feet).

#### **5.2.1.1 Survey Methods**

Sampling in Pamlico Sound proper (The Pamlico Sound Independent Gill Net Survey (PSIGNS)) was initiated in May of 2001. Sampling in the Neuse and Pamlico Rivers, referred to as the Rivers Independent Gill Net Survey (RIGNS), began in 2003 under the same sampling methodology. Since this time, both surveys have sampled continuously. Sampling locations are selected using a stratified random sampling design based on area and water depth (Figure 76). The PSIGNS was divided into eight areas: Hyde County 1 – 4 and Dare County 1 – 4. The RIGNS sampling area is divided into eight strata, four in the Neuse River (Upper, Upper-Middle, Middle-Lower, Lower) and four in the Pamlico River (Upper, Middle, Lower and Pungo River). Each areal strata was overlaid by a one minute by one minute grid (i.e., one square nautical

mile) with each grid classified into either a shallow (< 6 ft), deep (≥ 6 ft) or both depth stratum based on bathymetric maps.

Each areal stratum is sampled twice a month. For each random grid selected, both a shallow and deep sample were collected. Sets in the Pamlico Sound were made over a part of the year in 2001 (237 sets), and thereafter were sampled between 300 and 320 sets per year. Sets in the Rivers (Pamlico, Pungo, and Neuse) were made over a part of the year in 2003 (156 sets) and thereafter were sampled between 304 and 320 samples per year. Sample areas and coverage included in the PSIGNS and RIGNS surveys from 2001-2022 are provided in Figure 76.

For each grid selected, both the shallow and deep strata are sampled with a separate array (or gang) of nets. An array of nets consists of 30-yard segments of 3, 3½, 4, 4½, 5, 5½, 6, and 6½ in stretched mesh webbing (240 yards of gill net). Catches from this array of gill nets comprise a single sample, with two samples (one for the shallow strata, one for the deep strata) collected for each sampling trip. Gear was typically deployed within an hour of sunset and fished the following morning with effort made to keep all soak times within 12 hours. The 12-hour soak time allowed for uniform effort across all samples.

Physical and environmental conditions, including surface and bottom water temperature (°C), salinity (ppt), dissolved oxygen (mg/L), bottom composition, as well as a qualitative assessment of sediment size were recorded upon retrieval of the nets on each sampling trip. All attached submerged aquatic vegetation (SAV) in the immediate sample area was identified to species and density of coverage was estimated visually when possible. Additional habitat data recorded included distance from shore, presence or absence of sea grass or shell, and substrate type.

#### **5.2.1.2 Biological Sampling Methods**

Red drum for each mesh size (30-yard net) in a sample are enumerated with an aggregate weight (nearest 0.01 kg) obtained. Individuals are measured to the nearest millimeter FL.

Age data are available for each year and region from the survey. However, these data were not randomly collected but were taken as needed to provide representative samples by length bin during each monthly period sampled. Data should be valuable for growth curves and to inform the model on the age of fish captured in the survey.

#### **5.2.1.3 Catch Estimation Methods**

The time series in the rivers differs from that in the Pamlico Sound, therefore the results have typically been analyzed separately by area to evaluate the full time series of data: 1) Hyde and Dare counties (PSIGNS) only, beginning 2001, and 2) Rivers (Pamlico, Pungo, and Neuse; RIGNS), beginning 2003. The two areas can be combined as a single index beginning in 2003 and this was recommended for the index in the assessment due to the broader spatial coverage while only losing the two early years of data from the Pamlico Sound alone. The CPUE represents the number of red drum captured per sample. A collection represents one array of nets (shallow and deep combined) fished for 12 hours. Due to disproportionate sizes of each stratum and



region, the final CPUE estimate is weighted by aerial extent of strata with areas quantified using the one-minute by one-minute grid system.

Red drum catches in the survey vary across months. Due to this difference, only September, October, and November sets were used to develop a standardized index. A generalized linear model was constructed, with Poisson and negative binomial error distributions considered. The models were examined for best fit using dispersions (Zuur et al. 2009) and Akaike's Information Criterion (AIC; Akaike 1974). The best fit model was developed using a negative binomial error distribution with year and station as covariates (Poisson: AIC= 22,739, df=44, dispersion= 8.9; negative binomial AIC=11,846, df=27, dispersion=1.8).

### **5.2.2 Trends**

The standardized relative abundance showed a variable trend over the time series with the highest value occurring in 2012 (Table 30). Sampling was not conducted in 2020 due to COVID-19 impacts.

Red drum encountered by this survey were primarily between 28 and 70 cm (Figure 77).

### **5.2.3 Potential Biases, Uncertainty, and Measures of Precision**

Standard errors are presented for the annual estimates of standardized relative abundance (Table 30). Standard errors were relatively low (<0.2) for most years.

## **5.3 North Carolina Adult Longline Survey (NC\_Longline)**

### **5.3.1 Data Collection and Treatment**

The North Carolina Adult Longline Survey is a stratified-random survey occurring annually in Pamlico Sound that is designed to provide a fishery-independent relative abundance index for adult red drum in North Carolina. The survey has used continuous standardized sampling since 2007. The survey is designed to collect 72 stratified-random sets per year over a 12-week period from mid-July to mid-October.

#### **5.3.1.1 Survey Methods**

This survey employs a stratified-random sampling design based on area and time. Areas chosen for sampling were based on prior NCDMF mark and recapture studies, which indicate the occurrence of adult red drum within Pamlico Sound during the months of July through mid-October (Burdick et al. 2007; Bacheler et al. 2009). The sample area was overlaid with a one-minute by one-minute grid system (equivalent to one square nautical mile). Grids across the area were selected for inclusion in the sampling universe if they intercepted with the 1.8 m (6 ft) depth contour based on the use of bathymetric data from National Oceanic and Atmospheric Association (NOAA) navigational charts and field observations. Other factors, such as obstructions, accessibility, and logistics, were considered when grids were selected. Finally, the sample area was divided into twelve similarly sized regions (Figure 79). Two samples were

collected from each of the twelve regions during each of three periods from mid-July to mid-October.

A standardized sampling protocol that is replicated each year has been consistently utilized in the survey since 2007. All sampling was conducted using bottom longline gear. Lines were set and retrieved using a hydraulic reel. Ground lines consisted of 227 kg (500 lb) test monofilament. Samples were conducted with a 1,500-meter mainline with gangions placed at 15-meter intervals (100 hooks/set). Stop sleeves were placed at 30 m intervals to aid in accurate hook spacing and to prevent gangions from sliding down the ground line and becoming entangled when large species were encountered. Terminal gear was clip-on, monofilament gangions consisting of a 2.5 mm diameter stainless steel longline clip with a 4/0 swivel. Leaders on gangions were 0.7 m in length and consisted of 91 kg (200 lb) monofilament rigged with a 15/0 Mustad tuna circle hook. Hooks were baited with readily available baitfish (striped mullet is the primary bait and longline squid is the first alternative). Sets were anchored and buoyed at each end. Anchors consisted of a 3.3 kg window sash weight. Multiple sash weights were used in high current areas. All soak times were standardized and kept as close to 30 minutes as logistically possible. Soak times were measured from the last hook set to the first hook retrieved. Short soak times were designed to minimize bait loss, ensure that the red drum were tagged in good condition, and to minimize negative impacts to any endangered species interactions.

Within each randomly selected grid, two samples are taken. In order to maintain consistency, all samples were made in the vicinity of the 1.8 m depth contour with sample depths typically ranging from 1.2 to 4.6 m in depth. All random sampling occurred during nighttime hours starting at sunset. On average, a total of four sets were made per night.

Physical and environmental conditions, including surface and bottom water temperature (°C), salinity (ppt) and dissolved oxygen (mg/L), were recorded for each longline sample. Bottom composition and sediment size were recorded in the instances where they could be ascertained. Location of each sample was noted by recording the beginning and ending latitude and longitude.

#### **5.3.1.2 Biological Sampling Methods**

All individuals captured were processed at the species level and were measured to the nearest millimeter for both FL or TL and the presence or absence of drumming was noted. Most red drum were tagged (PIT and stainless-steel dart) and released, but a random sample including approximately every fifth fish collected was sacrificed for biological data collection, including the removal of otoliths for ageing.

#### **5.3.1.3 Catch Estimation Methods**

Catch rates were calculated annually, along with corresponding length class distributions. Since the model occurs on a fishing calendar from September through August, and the longline survey is the measure of the spawning individuals from July through October, all data from July

and August was bumped 1 fishing year to keep spawning aggregations in the same model year. The overall index is a standardized mean of the number of red drum captured per sample with environmental covariates taken into account. Longline sets were standardized to 100 hooks set at 15 m intervals for 30 minutes (measured as time elapsed from last hook set to first hook fished). The standardized index was estimated using a GLM approach, with Poisson and negative binomial error distributions considered. The models were examined for best fit using dispersions (Zuur et al. 2009) and Akaike's Information Criterion (AIC; Akaike 1974). The best fit model was developed using a negative binomial error distribution with year, grid, depth, bottom temperature, salinity, and DO as covariates (Poisson: AIC= 7,824, df=49, dispersion= 6.5; negative binomial AIC=4,798, df=31, dispersion=1.0).

### **5.3.2 Trends**

The index of relative abundance from 2007 to 2018 varied annually with little trend (Table 30 and Figure 80). The index value for 2022 was the lowest in the time series. It should be noted that the survey in 2019 was disrupted significantly by hurricane activity that occurred during the peak of the sample period and 2019 had a low relative abundance. The index value in 2018 was the highest of the time series. Sampling was not conducted in 2020 due to COVID-19 impacts.

The lengths of red drum captured ranged from 62 to 136 cm FL with most being between 86 and 114 cm FL. Length composition was similar across years (Figure 81).

Red drum ages collected from the survey ranged from age 3 to age 43 (Figure 82). Aggregated ages across all years of the survey plotted by year class (cohort) show the persistence of strong year classes (e.g., 1973, 1978, 1993, 2005) and weak year classes (e.g., 1977, 1988-1989, 1992, 2001-2002, 2009-2010) in the population over time (Figure 83). This trend appears consistent with variability in recruitment of YOY measured by the NC\_BagSeine survey.

### **5.3.3 Potential Biases, Uncertainty, and Measures of Precision**

Standard errors are presented for the standardized relative abundance and ranged from 0.20 to 0.27 (Table 30). The geographic range of the survey is limited to Pamlico Sound.

## **5.4 South Carolina Rotenone Survey (SC\_Rotenone)**

### **5.4.1 Data Collection and Treatment**

In the mid-1980s, the SCDNR began the development of long-term fishery-independent monitoring programs designed to monitor estuarine and coastal finfish populations along coastal South Carolina. One of these surveys, the Inshore Fisheries Rotenone Survey was designed to provide a survey of the estuarine finfish inhabiting estuarine, sub-tidal saltmarsh creek habitats. These creeks are less than 5 m wide and less than 1 m deep an hour before low tide; these habitats dominate the coastal South Carolina marsh environment. The survey was designed to provide relative abundance indices for key estuarine species, including red drum, as

the habitat sampled serves as a primary nursery habitat for a host of recreationally important estuarine species.

#### **5.4.1.1 Survey Methods**

Collections were made by blocking a 50 m long section of tidal creek with two 0.8 mm square mesh block nets, one at the upstream end of the section and one at the downstream end, about 1 hour before locally predicted time of low tide. The nets, with heavily weighted foot ropes, were suspended through the water column on lines stretched between poles sunk in the creek on opposite banks of the creek. Rotenone (100-200 ml of 5% Fish Tox, Wolfolk Chemical Works, Fort Valley, GA) was added at the upstream net and carried through the site with the ebbing current. At the down-stream net, potassium permanganate was added to the water leaving the site to oxidize the rotenone, thereby minimizing extra-site mortality. Immediately prior to the addition of rotenone, water temperature was measured with a stem thermometer and salinity was estimated with a refractometer. Dissolved oxygen was estimated with titration kit. Fish were collected within the site with dip nets and three pulls of a 3.2 mm bar mesh seine. The down-stream net was then carefully collected and those fish caught in it were removed. All specimens were returned to the lab for identification, enumeration, and measurement.

The SCDNR rotenone survey employed a fixed station sampling design. From 1986 through 1988, 7 sites, two in the ACE Basin estuary, 1 in the North Edisto and Stono River estuary, and 4 in the Charleston Harbor estuary were regularly sampled in at least two of the three years (Table 32). Beginning in 1989 through the end of the survey in 1994, sampling was conducted at 4 index stations in the Wando River Drainage, part of the Charleston Harbor estuary, in Charleston County, SC: Deep Creek, Foster Creek, Lachicotte Creek (sampled in 1986-1988), and PITA Creek (sampled in 1986-1988; Table 32).

#### **5.4.1.2 Biological Sampling**

Given the nature of the sampling procedure (rotenone) all collected fish were sacrificed and many were returned to the lab for final enumeration and the collection of biological information. Biological information for red drum included TL, SL, and weights with age determined based on length of capture. Owing to the small size of red drum encountered in the survey, there is limited information on sex with all encountered fish being considered immature.

A summary of the life history information provided to the benchmark assessment from the SCDNR rotenone survey is found in Table 33. Most individuals were exclusively aged based on size alone, as the survey encountered red drum prior to significant overlap in length distribution of individual cohorts, with near 100% certainty in the age determination of age-0 and age-1 fish (Figure 84). During the history of the survey, only 1 fish >1 year old was encountered, indicating that this survey represents a survey of red drum recruitment.

### 5.4.1.3 Catch Estimation Methods

During SEDAR 44, the SCDNR rotenone survey was presented as an age-0 index using data from September-December and an age-1 index using data from March-July, with the latter being primarily considered. However, the survey in actuality represents recruitment of red drum and can be readily converted to a survey of red drum year class strength, noting that young of the year red drum first recruit to the survey shortly after being born during the late summer and early fall and then persist in the survey through the winter, spring, and summer of the following year as calendar age-1 fish (Table 34). Under this treatment, there is no need for the development of age or length compositions, as it is assumed to be a survey of recruitment (e.g., year class strength) with a sampling year of August-July.

Under this framework, this recruitment index was standardized using a negative binomial generalized additive model (NB GAM) with year class (discrete), fixed sampling site (discrete), sampling stratum (discrete), a year class by fixed sampling site interaction term (discrete), a year class by sampling stratum interaction term (discrete), day of year (continuous; 9/1 = day 1), water temperature (°C, continuous) and salinity (PSU, continuous) being considered as potential covariates. Continuous covariates were fitted using a smoother using a cubic regression spline smoothing basis (Wood 2011; Wood 2017). Prior to model development any collections identified by the data provider as not suitable for use for index development were removed from consideration. Through investigation of all combinations of considered covariates, Bayesian Information Criterion (BIC) selected the best fit model,

$$\text{Catch} = \text{Year Class} + s(\text{DOY}, \text{bs} = ' \text{cr}' ) + s(\text{Temp}, \text{bs} = ' \text{cr}' ) + s(\text{Salinity}, \text{bs} = ' \text{cr}' ) + 1.$$

Year class effects were estimated using the best fit model using estimated marginal means using the *emmeans* package in R (Lenth 2023).

### 5.4.2 Trends

The SCDNR rotenone survey indicates above survey average recruitment of red drum in 1985, 1986, and 1990 (Table 35 and Figure 85). In other years, the abundance of red drum in the survey was reduced, with a stable to slightly decreasing trend in year class strength through time.

### 5.4.3 Potential Biases, Uncertainty, and Measures of Precision

The SCDNR rotenone survey was a fixed station survey with a limited number of sites (n = 9) with only a single site being sampled in all years (Table 32). Most sites sampled occurred in one river drainage along coastal South Carolina, the Wando River in Charleston Harbor. Further, the temporal duration of the survey was short, representing the catch of only eight red drum year classes from 1985-1993. Additionally, the SCDNR rotenone survey exhibits high relative standard errors (RSEs), with an average RSE of 0.55 (range: 0.43-0.77; Table 35).

That said, the survey represents a true recruitment index and correlates well with other contemporary surveys operating at the same time with reasonable measures of precision while covering a temporal period not covered by most other surveys. Further, the effect of sampling site and stratum on catchability was investigated through the standardization model, with neither variable being retained in the final best fit model suggesting synchrony in year class signals across space, as suggested by Arnott et al. (2010). The lack of a significant effect of site or stratum in the best fit index standardization model reduces the concerns surrounding the fixed station design.

## **5.5 South Carolina Stop Net Survey (SC\_StopNet)**

### **5.5.1 Data Collection and Treatment**

The second survey SCDNR began developing in the mid-1980s that encountered red drum was the Inshore Fisheries Stop Net Survey. This survey was designed to provide relative abundance indices for key estuarine species, including red drum, using salt marsh edge habitats. The survey indexed the relative abundance of numerous species and has been used in previous assessments of the southern stock of red drum.

#### **5.5.1.1 Survey Methods**

The stop net was 366 m long by 3 m deep with a 51 mm stretch mesh block net made of multifilament nylon mesh. The net was set at high tide in an intertidal area. One end was attached to a stake driven into the marsh surface, and then the net was laid out from a boat over the non-vegetated bottom parallel to the shore before securing the other end in the marsh with another stake. Upon deployment, the net enclosed a roughly semicircular area of approximately 12,000 m<sup>2</sup>. Fishes trapped in the enclosed area were collected with large dip nets as the tide dropped and selected species, including red drum, were placed in oxygenated holding tanks and held until they could be measured, tagged, and released, or retained for life-history workup. Immediately after net deployment, water temperature was measured with a stem thermometer and salinity was estimated with a refractometer. Dissolved oxygen was estimated with a titration kit.

Stop net sampling took place from 1985 through 1998, but monthly survey sampling occurred at a single site in Charleston Harbor (Grice Cove) from the summer of 1986 through 1993, with most months sampled in 1994 (Table 35). A secondary site in northern Bulls Bay (Bull Island) was sampled primarily during summers from 1990 through 1994, with a smattering of additional sites sampled throughout the survey history (Table 35). As such, only collections made at these two fixed stations were considered when developing the index.

#### **5.5.1.2 Biological Sampling**

Life history sampling of priority species, including red drum, was performed through the application of length distribution subsampling, with the number sacrificed for life history studies varying depending on species. Sacrificed red drum had additional biological variables ascertained (e.g., weight (g) and macroscopic reproductive stage) and biological samples

retained (e.g., otoliths for age and growth studies, scales for age and growth studies and ageing methodology comparisons, gonad tissues for histological determination of reproductive status, and muscle tissues for contaminant analysis).

A summary of the length and weight information provided to the simulation assessment from the SCDNR stop net survey is found in Table 33. A combination of age methodologies was used to age red drum encountered by the SCDNR stop net survey, dependent on the size of the individual fish. Smaller individuals (less than 2.5 years old), prior to significant overlap in length distribution of individual cohorts, can be reliably aged exclusively using TL, with near 100% certainty in the age determination of biological age-0 and -1 fish, as verified by otolith thin-section methodology (Figure 84). The ages of larger, and hence generally older, individuals have been determined via a combination of scale readings and otolith thin-section techniques, though all scale derived ages were excluded from consideration during the assessment.

### 5.5.1.3 Catch Estimation Methods

While the SCDNR stop net survey was included as an index during SEDAR 44, it was presented as an age-1 relative abundance index, with age-1 catch (based on a calendar year definition) in the survey occurring from Jul-Dec annually. They used this framework as there was a need for age-specific indices in the historical custom statistical catch-at-age model used to assess the southern stock. Herein, the SAS decided to use age-aggregated indices, where appropriate, with accompanying length-, age- or conditional age-at-length-compositions.

Under this framework, this sub-adult index was standardized using a negative binomial generalized additive model (NB GAM) with fishing year (discrete; 1986-1993), fixed sampling site (discrete), day of year (continuous; 9/1 = day 1), water temperature (°C, continuous) and salinity (PSU, continuous) being considered as potential covariates. Continuous covariates were fitted using a smoother using a cubic regression spline smoothing basis (Wood 2011; Wood 2017). Prior to model development, data was subset to only include collections made at the Grice Cove and Bull Island sites (Table 36). In addition, any collections identified as not suitable for use for index development were removed from consideration. Through investigation of all combinations of considered covariates, Bayesian Information Criterion (BIC) selected the best fit model,

$$Catch = Year + s(DOY, bs = 'cr') + 1.$$

Fishing year effects were estimated using the best fit model using estimated marginal means using the *emmeans* package in R (Lenth 2023).

Length compositions for the survey were developed from the observed TL measurements made on all individuals encountered by the survey, with both annual (calendar year and fishing year) and seasonal (2-season (Sept-Feb. & Mar.-Aug.) and 3-season (Sept.-Dec., Jan-Apr., & May-Aug.)) compositions developed initially. There was no need for expansion of the length compositions given the survey sampling design. Compositions were developed using 2 cm length bins (e.g., 0-19 mm TL = 0 cm bin, 20-39 mm TL = 3 cm bin, etc.).

The SAS recommended use of the annual fishing year (September 1-August 31) compositions in the base model given the use of the fishing year as the annual time step, though preliminary effects of incorporation of the seasonal compositions on assessment model results were investigated. The all-years pooled length composition for the survey can be found in Figure 86. Modes in the pooled length composition reflect cohorts of red drum encountered by the survey, with the mode at 24-28 cm, 36-40 cm, and > 56 cm TL corresponding to age-0, age-1, and age-2+ red drum encountered by the survey.

Age compositions for the survey were developed using paired TL and age measurements made on all individuals encountered by the survey, with both annual (calendar year and fishing year) and seasonal (2-season (Sept.-Feb. & Mar.-Aug.) and 3-season (Sept.-Dec., Jan-Apr., & May-Aug.)) compositions developed initially. Annual age compositions for the survey were not directly available, owing to the stratified random sampling design used to select fish to sacrifice for age determination via otoliths. Thus, to develop annual marginal age compositions we used proportional odds logistic regression to develop smoothed annual age-length-keys (ALK) conditional on the model

$$Age = a * TL + b * Year + c,$$

where *Age* is an ordered (smallest to largest) observed integer, biological age based on otolith or length derived age estimates, *TL* is a 2-cm TL bin (see length compositions) and *Year* represents the fishing year of capture (Agresti 2002; Ogle 2018; Stari et al. 2010; Venables & Ripley 2002). The resultant best fit model was used to determine the biological age of all un-aged (e.g., un-aged or originally aged-via scales) red drum captured from the stop net survey for which a TL (and hence TL bin) was available. These smoothed ALK “aged” fish were then added to the fish directly aged to develop marginal age compositions for each fishing year.

The SAS recommended use of the annual fishing year (September 1-August 31) compositions in the base model given the use of the fishing year as the annual time step, though preliminary effects of incorporation of the seasonal compositions on assessment model results were investigated. The resultant all-years pooled marginal age composition for red drum can be found in Figure 87, which clearly shows the majority of fish captured in the survey are either age-0 or age-1, with fewer age-2, age-3, and age-4+ fish encountered.

In the stock synthesis framework, the model can also utilize conditional age-at-length information where information on aged fish in length bins (i.e., raw ALK) by year and survey can be directly incorporated into the model to inform selectivity, growth, and natural mortality. To facilitate the incorporation of conditional age-at-length information from the SCDNR stop net survey, raw age (length and otolith derived) and length information was provided to the benchmark assessment.

### 5.5.2 Trends

Overall, the SCDNR stop net survey shows a relatively stable abundance of sub-adult red drum along coastal South Carolina throughout the survey time series (Table 37 and Figure 88). The



SCDNR stop net survey exhibits moderate RSEs, with an average RSE of 0.26 (range: 0.24-0.29, Table 37).

Annual length compositions available from the SCDNR stop net survey shows individual cohorts of red drum (identified by modes) being encountered by the survey (Figure 89), with the peaks of the modes of the length compositions elucidating information on the formation of strong and weak year classes based on length alone. From the age compositions, we see that either age-0 (1985, 1986, 1989, & 1990 fishing years) or age-1 (the remaining fishing years) red drum were most commonly encountered by the survey, though in most years individuals of at least age-3 were observed (Figure 90).

### **5.5.3 Potential Biases, Uncertainty, and Measures of Precision**

The SCDNR stop net survey represents a single fixed station along coastal South Carolina over a relatively short time period (10 fishing years), limiting its utility as a coastwide index of relative abundance for the southern stock. In addition, there is low sampling intensity within a year at those fixed stations, owing to the time required for a single collection. Combined, these attributes lead to higher than desired measures of precision on annual estimates of relative abundance ( $RSE \bar{X} = 0.26$ , range = 0.24-0.29; Table 37). However, this survey is one of a select few that provides any information on the relative abundance of sub-adult red drum in the late-1980s and early 1990s.

## **5.6 South Carolina Trammel Net Survey (SC\_Trammel)**

### **5.6.1 Data Collection and Treatment**

The SCDNR established the SCDNR trammel net survey in the fall of 1990 as a survey of lower estuary, moderate- to high-salinity, salt-marsh edge and oyster reef habitats; these habitats dominate the coastal South Carolina estuarine shoreline environment. The survey was designed to provide relative abundance indices for key estuarine species including red drum, as the habitat sampled serves as a primary habitat for a host of recreationally important estuarine species. The survey indexes the relative abundance of numerous species throughout the five major estuaries found along the South Carolina coast (Figure 91) and has been used in numerous stock assessments as an index of relative abundance, including previous assessments of the southern stock of red drum.

#### **5.6.1.1 Survey Methods**

The SCDNR trammel net survey employs a stratified random fixed station sampling design. On each sampling day (one stratum is sampled day<sup>-1</sup>), 12-14 stations are selected at random (without replacement) from a current pool of 27 to 36 possible fixed stations stratum<sup>-1</sup>, with the exception that adjacent sites (unless separated by a creek or other barrier) cannot be sampled on the same day to avoid sampling interference. Field crews typically set at 10-14 of the randomly selected sites day<sup>-1</sup>, although weather, tide, or other constraints sometimes hinders this target.

Protocols for each individual trammel net set are temporally and spatially consistent since the implementation of the survey in the fall of 1990. Fish are collected using a 183 x 2.1 m trammel net fitted with a polyfoam float line (12.7 mm diameter) and a lead core bottom line (22.7 kg). The netting comprises an inner panel (0.47 mm #177 monofilament; 63.5 mm stretch-mesh; height = 60 diagonal meshes) sandwiched between a pair of outer panels (0.9 mm #9 monofilament; 355.6 mm stretch-mesh; height = 8 diagonal meshes). Staff set individual trammel nets (one site<sup>-1</sup> day<sup>-1</sup>) along the shoreline (10-20 m from an intertidal marsh flat, <2 m depth) during an ebbing tide using a fast-moving Florida mullet skiff, anchoring each end of the net on the shore or in shallow marsh habitat. Once set, the boat makes two passes along the length of the enclosed water body at idle speed (taking <10 minutes), during which time field personnel disturb the water surface with wooden poles to promote fish entrapment. Field staff then at once retrieve the net and place netted fish in a live well.

Once staff complete net retrieval at a site, they then identify to the species level and count all captured specimens (fish and crustaceans). For red drum and other recreationally important species (black drum, spotted seatrout, southern flounder, sheepshead, spot, Atlantic croaker, southern kingfish, etc.), field staff record lengths from every individual caught. For other species, staff take measurements from all individuals unless large catches occurred; in such instances, staff measure a sub-sample of twenty-five fish species<sup>-1</sup> from each trammel net collection. Staff record different length measurements depending on the species and catches, though staff record stretched total lengths (TL), fork lengths (FL), and standard lengths (SL) where possible. Staff release most fish (>95%) alive at the site of capture once they obtain length measurements. Any red drum greater than 350 mm TL released at the site of capture and not previously tagged are tagged, with tag type dependent on the size of the individual. Individuals between 350- and 549-mm TL are tagged with disc belly tags, and any greater than 549 mm TL are tagged with a steel shoulder tag.

Additional data collected during each collection includes location (site nested in stratum nested in estuary, latitude, and longitude) and a suite of physical and environmental variables. Physical and environmental variables recorded include depth (m), air temperature (°C), water temperature (°C), salinity (PSU), dissolved oxygen (mg L<sup>-1</sup>), and tidal stage.

Additional details in a visual format regarding the SCDNR trammel net survey can be found in an online video published by SCDNR ([https://youtu.be/d8\\_VNKIsFPQ?si=Fcs9hCWUQPqjiGdl](https://youtu.be/d8_VNKIsFPQ?si=Fcs9hCWUQPqjiGdl)).

At present, nine strata, from south to north, are surveyed: Colleton River (CT), Broad River (BR), ACE Basin (AB), Ashley River (AR), Charleston Harbor (CH), Wando River (LW), Muddy & Bulls Bays (MB), Romain Harbor (RH), and Winyah Bay (WB). These nine strata are found in the five primary South Carolina estuaries, Port Royal Sound (CT & PR), St. Helena Sound (AB), Charleston Harbor (AR, CH, LW), Cape Romain and Bulls Bay (ME & CR), and Winyah Bay (WB). Note however, the time series of sampling in each estuary has varied through time (Table 38). Limited historical data is also available from additional strata and areas within current strata but are excluded from the development of relative abundance indices due to temporal length of surveys in these areas.

From November 1990 through the 2022 fishing year, the SCDNR trammel net survey had made 27,226 collections along the South Carolina coastline, in the 9 contemporary strata and one historical strata (CR) that was split into two of the contemporary strata (MB & RH), of which 26,094 were initially available for the construction of the red drum index of relative abundance (Table 39).

#### **5.6.1.2 Biological Sampling Methods**

Life history sampling of priority species, including red drum, is performed through the application of length distribution subsampling, with the number sacrificed for life history studies varying depending on the species. Sacrificed red drum (~300-500 per year) have several additional biological variables ascertained (e.g., weight (g) and macroscopic reproductive sex) and biological samples retained (e.g., otoliths for age and growth studies, scales for age and growth studies and ageing methodology comparisons, gonad tissues for histological determination of reproductive status, and muscle tissues for contaminant analysis).

A summary of the life history information provided to the benchmark assessment from the SCDNR trammel net survey is found in Table 33. A combination of age methodologies is used to age red drum encountered by the SCDNR trammel net survey, dependent on the size of the individual fish. Smaller individuals (<2.5 years old), prior to significant overlap in length distribution of individual cohorts, can be reliably aged exclusively using TL, with near 100% certainty in the age determination of calendar age-0 and 1 fish, as verified by otolith thin-section methodology (Figure 84). The ages of larger, and hence generally older, individuals have been determined via a combination of scale readings and otolith thin-section techniques, though all scale derived ages were excluded from consideration during the assessment.

#### **5.6.1.3 Catch Estimation Methods**

While the SCDNR trammel net survey was included as an index during SEDAR 44, it was presented as an age-specific calendar age-1 sub-adult index, an age-specific calendar age-2 sub-adult index, an age-aggregate calendar age 2-5 sub-adult index, and as a calendar age-aggregate index. The age-specific age-1 and age-2 indices were included in the final SEDAR 44 assessment model. They used this framework as there was a need for age-specific indices in the historical custom statistical catch-at-age model used to assess the southern stock. Herein, the SAS decided to use age-aggregated indices, where appropriate, with accompanying length-, age- or conditional age-at-length compositions.

Under this framework, this index was standardized to account for the impact covariates (Discrete: fishing year (1991-2022), stratum, stratum by year interaction, random (randomly selected = 1; non-randomly selected = 0), and tidal stage (early-ebb, mid-ebb, late-ebb); Continuous: day of year (9/1 = day 1), water temperature (°C), and salinity (PSU); Random: Site) had on collection level catchability of red drum. The inclusion of the “site” level random effect led to the investigation of a best fit model using either a negative binomial generalized additive model (NB GAM) or negative binomial generalized additive mixed model (NB GAMM) framework with fishing year as the primary variable of interest. Data was filtered to only retain fixed stations (e.g., “sites”) where we had captured red drum throughout the history of the

survey, only collections in ebb (early-, mid-, or late-ebb) tidal stages and those not missing continuous covariate data. Continuous covariates were fitted using a smoother using a cubic regression spline smoothing basis (Wood 2011; Wood 2017). In NB GAMM models, the site random effect was fit using a smoother using a ridge penalty which is equivalent to an assumption that the coefficients are independent and identically distributed random effects (Wood 2008). Through investigation of all combinations of considered covariates, BIC selected the best fit NB GAMM model,

$$Catch = Year + Stratum + Tidal Stage + s(DOY, bs = 'cr') + s(Site, bs = 're') + 1.$$

Fishing year effects were estimated using the best fit model using estimated marginal means using the *emmeans* package in R (Lenth 2023).

Length compositions for the survey were developed from the observed TL measurements made on all individuals encountered by the survey, with both annual (calendar year and fishing year) and seasonal (2-season (Sept.-Feb. & Mar.-Aug.) and 3-season (Sept.-Dec., Jan-Apr., & May-Aug.)) compositions developed initially. There was no need for expansion of the length compositions given the survey sampling design. Compositions were developed using 2 cm length bins (e.g., 0-19 mm TL = 0 cm bin, 20-39 mm TL = 3 cm bin, etc.).

The SAS recommended use of the annual fishing year (September 1-August 31) length compositions in the base model given the use of the fishing year as the annual time step, though preliminary effects of incorporation of the seasonal compositions on assessment model results were investigated. The all-years pooled length composition for the survey can be found in Figure 92. Modes in the pooled length composition reflect cohorts of red drum encountered by the survey, with the mode at 24-28 cm, 38-42 cm, and >58 cm TL corresponding to age-0, age-1, and age-2+ red drum encountered by the survey.

Age compositions for the survey were developed using paired TL and age measurements made on all individuals encountered by the survey, with both annual (calendar year and fishing year) and seasonal (2-season (Sept.-Feb. & Mar.-Aug.) and 3-season (Sept.-Dec., Jan-Apr., & May-Aug.)) compositions developed initially. Annual age compositions for the survey were not directly available, owing to the stratified random sampling design used to select fish to sacrifice for age determination via otoliths. Thus, to develop annual marginal age compositions we used proportional odds logistic regression to develop smoothed annual age-length-keys (ALK) conditional on the model

$$Age = a * TL + b * Year + c,$$

where *Age* is an ordered (smallest to largest) observed integer, biological age based on otolith or length derived age estimates, *TL* is a 2-cm TL bin (see length compositions) and *Year* represents the fishing year of capture (Agresti 2002; Ogle 2018; Stari et al. 2010; Venables & Ripley 2002). The resultant best fit model was used to determine the biological age of all un-aged (e.g., un-aged or originally aged-via scales) red drum captured from the trammel net

survey for which a TL (and hence TL bin) was available. These smoothed ALK “aged” fish were then added to the fish directly aged to develop marginal age compositions for each fishing year.

The SAS recommended use of the annual fishing year (September 1-August 31) age compositions in the base model given the use of the fishing year as the annual time step, though preliminary effects of incorporation of the seasonal compositions on assessment model results were investigated. The resultant all-years pooled marginal age composition for red drum can be found in Figure 93, which clearly shows the majority of fish captured in the survey are either age-0, age-1, age-2, or age-3, with fewer age-4 and age-5+ fish encountered.

In the stock synthesis framework, the model can also utilize conditional age-at-length information where information on aged fish in length bins (i.e., raw ALK) by year and survey can be directly incorporated into the model to inform selectivity, growth, and natural mortality. To facilitate the incorporation of conditional age-at-length information from the SCDNR trammel net survey, raw age (length and otolith derived) and length information was provided to the benchmark assessment.

### **5.6.2 Trends**

Overall, the SCDNR trammel net survey shows a decrease in abundance of sub-adult red drum along coastal South Carolina since the survey’s inception, only briefly offset by a period of good recruitment in the early 2000s (Table 40 and Figure 94). Record low abundances have been observed in recent years, though there has been a slight uptick since the 2019 fishing year.

Annual length compositions available from the SCDNR trammel net survey shows individual cohorts of red drum (identified by modes) being encountered by the survey, with the peaks of the modes elucidating information on the formation of strong and weak year classes (Figure 95). From the age compositions, we see that either age-0 (2000, 2015-2016), age-1 (1991-1992, 1994-1995, 1997, 2001-2002, 2007-2010, 2013-2014, and 2021), or age-2 (the remaining fishing years) red drum were most commonly encountered by the survey, though in most years individuals of at least age-3 were observed (Figure 96). Evidence of the strong 2000-year class shows up in the 2000 length and age compositions, which seems to support a temporary increase in relative abundance across the state, as observed in the index.

### **5.6.3 Potential Biases, Uncertainty, and Measures of Precision**

Overall, the SCDNR trammel net exhibits low RSEs, with an average RSE of 0.097 (range: 0.085-0.18; Table 40). Further, confidence in the index increases through time due to the expansion of the survey spatially leading to an increase in sampling intensity across the state. In addition, the long time series (32 years) provides the most comprehensive insight into the long-term trends in sub-adult red drum populations along coastal South Carolina.

## 5.7 South Carolina Historic Longline Survey (SC\_Longline\_historic)

### 5.7.1 Data Collection and Treatment

To monitor populations of adult red drum in South Carolina's estuarine and coastal ocean waters, a longline survey off of Charleston (Figure 97) was established in 1994. A primary focus of the survey was to develop an index of relative abundance of adult red drum to develop a better understanding of red drum populations along the southeastern Atlantic coast, thereby allowing for more effective and responsible management of the stock. As such, the survey collected data on the CPUE for indices of abundance and length measurements of all red drum encountered. Further, released red drum were tagged to collect migration and stock identification data.

#### 5.7.1.1 Survey Methods

In the first year of the study, a cable mainline (1,829 meter long) with one hundred hooks was deployed. Following discussion that sharks may be deterred by the cable (as sharks were also a target species), a 600-lb test, 1,829-meter monofilament mainline was also used with 120 hooks starting in 1995, and both gear types were used until 1997. In 1998, the survey switched to monofilament mainline for all sets, since it was concluded that while the cable gear decreased the catch of sharks, red drum catches were unaffected by the gear. Terminal tackle, regardless of mainline type, was composed of 0.5 m of 200 lb. test monofilament, with a 2.5 mm stainless steel longline clip affixing it to the mainline and a 15/0 Mustad circle hook. The hooks were primarily baited with Atlantic mackerel and spot, though bait used was not tracked at the collection level. Field crews targeted a 30-minute soak time (1st hook down to 1st hook up), though the overall retrieval time for the gear varied depending on the catch.

The majority of effort took place at index stations in Charleston Harbor (across 5 main fixed stations at the Charleston jetties or nearshore habitats off Charleston Harbor with live bottom; 0), with additional exploratory sets in Port Royal Sound in 2005 and in Winyah Bay and Port Royal Sound in 2006. Two vessels have been used since the survey began, the *R/V Anita* (1994-2004) and the *R/V Silver Crescent* (2005-2006). The mile-long (1,829 m) monofilament mainline was used until the survey design was modified in 2007 (with limited mile-long sets in 2007) from fixed sites to a stratified random design with 600-meter monofilament mainlines. Existing index stations were broken into three 600 m sets, and new stations were added based on suitable habitat and previous exploratory sets (see Section 5.9 for full contemporary description).

Within a year, sampling was conducted in each month of the year, though red drum catches were greater during the August-December period leading to a gradual increase in overall survey effort during this time frame. From 1994 to 2006, the SCDNR historic coastal longline survey made 1,083 collections that were used in the construction of the historic longline red drum index of relative abundance (Table 41).

### 5.7.1.2 Biological Sampling

Staff brought each fish captured on the longline on board where they removed the hook and measured each fish to the nearest mm FL (i.e., mid-line length) and TL. At the conclusion of initial workup, staff tagged and released each individual using three different tag types: nylon dart tag (1994-2006), PIT tag (2001-2006), and stainless-steel dart tag (2001-2006). In addition, staff took fin clips from all encountered red drum from 2003-2006 and a limited number of fish were sacrificed for age and reproductive status determination. A summary of the life history information provided to the benchmark assessment from the SCDNR historic longline survey is found in Table 33.

### 5.7.1.3 Catch Estimation Methods

Using only CPUE data on red drum collected during the months of August through December at the five fixed stations (i.e., “sites”) routinely sampled, the relative abundance index was standardized to account for the impact covariates (Discrete: fishing year (1994-2006), site, site by year interaction, and gear type (mono vs. cable mainline); Continuous: day of year (1/1 = day 1)) had on collection level catchability of red drum. The number of hooks was included as an offset term in the considered NB GAM models to account for differences in effort, with the best fit model chosen based on BIC. Continuous covariates were fitted using a smoother using a cubic regression spline smoothing basis (Wood 2011; Wood 2017). Through investigation of all combinations of considered covariates, the best fit NB GAM model was

$$Catch = Year + Site + s(DOY, bs = 'cr') + offset(\ln(hooks)) + 1.$$

Fishing year effects were estimated using the best fit model using estimated marginal means using the *emmeans* package in R (Lenth 2023).

Annual length compositions for the survey were developed from the observed TL measurements made on all individuals encountered by the survey. There was no need for expansion of the length compositions given the survey sampling design. Compositions were developed using 2 cm length bins (e.g., 0-19 mm TL = 0 cm bin, 20-39 mm TL = 3 cm bin, etc.). The all-years pooled length composition for the survey can be found in Figure 98.

Marginal age compositions for the historic longline survey were not developed owing to the small sample size of aged fish ( $n = 98$ ), the limited years where any fish were aged (1996, 2001, 2004-2006;  $n > 10$  aged only in 1996-1999), and the large number of year classes represented by the length composition for this adult survey. While attempts to develop marginal age composition using smoothed ALKs using proportional odds logistic regression modelling were made, the SAS did not recommend using the marginal age compositions in the assessment.

In the stock synthesis framework, the model can also utilize conditional age-at-length information where information on aged fish in length bins (i.e., raw ALK) by year and survey can be directly incorporated into the model to inform selectivity, growth, and natural mortality. To facilitate the incorporation of conditional age-at-length information from the SCDNR historic

longline survey, raw age (otolith derived) and length information was provided to the benchmark assessment.

### **5.7.2 Trends**

The SCDNR historic longline survey indicates a stable trend of adult red drum abundance throughout the time series (Table 42 and Figure 99). The exceptions were notably below average relative abundance in 1997 and 2000. The SCDNR historic longline survey exhibits moderate RSEs, with an average RSE of 0.19 (range: 0.16-0.33; Table 42). In addition, the survey provides the only insight into the long-term trends in adult red drum populations along coastal South Carolina from 1994-2006.

Annual length compositions available from the SCDNR historic longline survey shows little trend in the sizes of red drum being encountered by the survey (Figure 100). This is to be expected given the slowing of growth of adult red drum and the number of year classes over which the annual survey is integrating information over. Annual marginal age compositions are not presented as the SAS recommended not using age compositions developed for the historic longline survey (see Section 5.7.1.3).

### **5.7.3 Potential Biases, Uncertainty, and Measures of Precision**

Overall, the SCDNR historic coastal longline survey exhibits moderate RSEs, with RSEs ranging from 0.16-0.33 (Table 42). Further, it represents the only source of historical information on the abundance of mature, adult fish. However, the design of this survey (fixed station survey) and limited geographic scope (Charleston Harbor, SC, only) confounds the interpretation of relative abundance trends obtained. Further, there are potential sampling complications since the survey was modified from a survey designed to capture sharks initially. Though length information is available, the lack of age composition information from the survey may limit its ability to inform historic recruitment.

## **5.8 South Carolina Electrofishing Survey (SC\_Electro)**

### **5.8.1 Data Collection and Treatment**

The SCDNR established the SCDNR electrofishing survey in February 2001 as a survey of upper estuary (low salinity), river-bank waters which are important habitat for juvenile stages of fish (e.g., red drum, spotted seatrout, southern flounder, spot, and Atlantic menhaden). The survey indexes the relative abundance of numerous species throughout five tidally influenced freshwater riverine systems found along the South Carolina coast (Figure 91).

#### **5.8.1.1 Survey Methods**

The SCDNR electrofishing survey employs a stratified random fixed station sampling design. On each sampling day (one stratum is sampled day<sup>-1</sup>), 6-8 stations are selected at random (without replacement) from a pool of 72 to 208 stations stratum<sup>-1</sup>. Sampling stations within each stratum include sections of riverbank measuring a quarter of a nautical mile (~463 m). Field crews



typically conduct electrofishing at 5-6 of the randomly selected sites day<sup>-1</sup>, although weather, tide, or other constraints sometimes hinders this target. In particular, the field crew may need to shift up or downriver due to salinity fluctuations associated with drought or flood conditions as the boat-based electrofishing gear only works effectively at salinities < ~8 PSU. Hence the prior selection of more stations than can be sampled on a given day.

Protocols for each individual electrofishing set are temporally and spatially consistent since the implementation of the survey. We collect fish while running the electrofishing boat (Smith-Root) at ~3000 W pulsed direct current at a frequency of 120 Hz. SCDNR Inshore Fisheries staff place stunned fish into a live well using dip nets (4.5 mm square-mesh) over a 15-minute (900 s) period while the boat moves with the current at drift or idle speed along the riverbank. Once staff complete the 15-minute electrofishing pass along the riverbank, they then identify individuals to the species level and count all captured specimens. For red drum and other recreationally important species (e.g., spotted seatrout, southern flounder, sheepshead), field staff record lengths (in mm) from every individual caught. For other species, staff measure a sub-sample of twenty-five fish species<sup>-1</sup> for each electrofishing collection. Staff record different length measurements based on the species and catches, though staff record stretched total lengths (TL), fork lengths (FL), and standard lengths (SL) where possible. Staff release most fish (>95%) alive at the site of capture once they obtain length measurements. Any red drum greater than 350 mm TL released at the site of capture and not previously tagged are tagged, with tag type dependent on the size of the individual. Individuals between 350- and 549-mm TL are tagged with disc belly tags, and any greater than 549 mm TL are tagged with a steel shoulder tag.

Additional data collected during each collection includes location (site nested in stratum nested in estuary; latitude and longitude) and a suite of physical and environmental variables. Physical and environmental variables recorded include depth (m), air temperature (°C), water temperature (°C), salinity (PSU), dissolved oxygen (mg L<sup>-1</sup>), and tidal stage. In addition, boat settings for each individual electrofishing pass are typically recorded, including voltage (V; peak and average), current or amperes (A; peak and average), power (Watts (W); peak and average), current frequency (Hz), duty cycle (%), voltage range (e.g., 120/170), and percent frequency knob (setting on boat).

At present, five strata, from south to north, are surveyed: Combahee River (CM), Edisto River (LE), Ashley River (UA), Cooper River (UC), and Waccamaw/Sampit Rivers (EW). These five strata are found in three different estuarine systems, St. Helena Sound (CM and LE), Charleston Harbor (UA and UC), and Winyah Bay (EW). Note, however, the time series of sampling in each estuary has varied through time (Table 43). Limited historical data is also available from additional strata and areas within current strata but are excluded from the development of relative abundance indices due to temporal length of surveys in these areas.

From 1990 thru the 2022 fishing year, the SCDNR trammel net survey made 6,632 collections along the South Carolina coastline in the five contemporary strata (Table 44).

### 5.8.1.2 Biological Sampling Methods

Life history sampling of priority species, including red drum, is performed through the application of length distribution subsampling, with the number sacrificed for life history studies varying depending on the species. Sacrificed red drum have additional biological variables ascertained (e.g., weight (g) and macroscopic reproductive sex) and biological samples retained (e.g., otoliths for age and growth studies, scales for age and growth studies and ageing methodology comparisons, gonad tissues for histological determination of reproductive status, and muscle tissues for contaminant analysis).

A summary of the life history information provided to the benchmark assessment from the SCDNR electrofishing survey is found in Table 33. A combination of age methodologies is used to age red drum encountered by the survey, dependent on the size of the individual fish. Smaller individuals (<2.5 years old), prior to significant overlap in length distribution of individual cohorts, can be reliably aged exclusively using TL, with near 100% certainty in the age determination of calendar age-0 and 1 fish, as verified by otolith thin-section methodology (Figure 84). The ages of larger, and hence generally older, individuals have been determined via a combination of scale readings and otolith thin-section techniques, though all scale derived ages were excluded from consideration during the assessment.

### 5.8.1.3 Catch Estimation Methods

While the SCDNR electrofishing survey was included as an index during SEDAR 44, it was presented as an age-specific calendar age-1 sub-adult index. They used this framework as there was a need for age-specific indices in the historical custom statistical catch-at-age model used to assess the southern stock. The index was not included in the final model but was used as a corroborative index supporting the choice of other indices. It was noted to show good agreement with the SCDNR trammel net survey, with its primary reason for exclusion being it had a shorter time series than the SCDNR trammel net survey while providing the same signal (sub-adult calendar age-1 abundance) to the assessment model. Herein, the SAS decided to use age-aggregated indices, where appropriate, with accompanying length-, age- or conditional age-at-length compositions.

Under this framework, this index was standardized to account for the impact covariates (Discrete: fishing year (2001-2022), stratum, stratum by year interaction, random (randomly selected = 1; non-randomly selected = 0), tidal stage (early-flood, mid-flood, late-flood, high, early-ebb, mid-ebb, late-ebb, low), and voltage range (85, 170, 340 or 680); Continuous: day of year (9/1 = day 1), water temperature (°C), salinity (PSU), dissolved oxygen (mg L<sup>-1</sup>), percent knob setting (0-100%), and Secchi disk depth (m); Random: Site)) had on collection level catchability of red drum. The sampling duration (in minutes) was included as an offset term in the considered NB GAM and NB GAMM models to account for differences in effort. The inclusion of the “site” level random effect led to the investigation of a best fit model using either a NB GAM (no site random effect) or NB GAMM framework with fishing year as the primary variable of interest. Data was filtered to only retain fixed stations (e.g., “sites”) where we had captured red drum throughout the history of the survey and those not missing

continuous covariate data. Continuous covariates were fitted using a smoother using a cubic regression spline smoothing basis (Wood 2011; Wood 2017). In NB GAMM models, the site random effect was fit using a smoother using a ridge penalty which is equivalent to an assumption that the coefficients are independent and identically distributed random effects (Wood 2008). Through investigation of all combinations of considered covariates, BIC selected the best fit NB GAM model,

$$\text{Catch} = \text{Year} + \text{Stratum} + \text{Voltage Range} + s(\text{Percent}, \text{bs} = 'cr') + \text{offset}(\ln(\text{Duration})) + 1.$$

Fishing year effects were estimated using the best fit model using estimated marginal means using the *emmeans* package in R (Lenth 2023).

Length compositions for the SCDNR electrofishing survey were developed from the observed TL measurements made on all individuals encountered, with both annual (calendar year and fishing year) and seasonal (2-season (Sept-Feb. & Mar.-Aug.) and 3-season (Sept.-Dec., Jan-Apr., & May-Aug.)) compositions developed initially. There was no need for expansion of the length compositions given the survey sampling design. Compositions were developed using 2 cm length bins (e.g., 0-19 mm TL = 0 cm bin, 20-39 mm TL = 3 cm bin, etc.).

The SAS recommended use of the annual fishing year (September 1-August 31) length compositions in the base model, though preliminary effects of incorporation of the seasonal compositions on assessment model results were investigated. The all-years pooled length composition for the survey can be found in Figure 101. The primary mode in the pooled length composition at 38-42 cm corresponds to age-1 red drum encountered by the survey.

Age compositions for the survey were developed using paired TL and age measurements made on all individuals encountered by the survey, with both annual (calendar year and fishing year) and seasonal (2-season (Sept-Feb. & Mar.-Aug.) and 3-season (Sept.-Dec., Jan-Apr., & May-Aug.)) compositions developed initially. Annual age compositions for the survey were not directly available, owing to the stratified random sampling design used to select fish to sacrifice for age determination via otoliths. Thus, to develop annual marginal age compositions we used proportional odds logistic regression to develop smoothed annual age-length-keys (ALK) conditional on the model

$$\text{Age} = a * \text{TL} + b * \text{Year} + c,$$

where *Age* is an ordered (smallest to largest) observed integer, biological age based on otolith or length derived age estimates, *TL* is a 2-cm TL bin (see length compositions) and *Year* represents the fishing year of capture (Agresti 2002; Ogle 2018; Stari et al. 2010; Venables & Ripley 2002). The resultant best fit model was used to determine the biological age of all un-aged (e.g., un-aged or originally aged-via scales) red drum captured from the electrofishing survey for which a TL (and hence TL bin) was available. These smoothed ALK “aged” fish were then added to the fish directly aged to develop marginal age compositions for each fishing year.

The SAS recommended use of the annual fishing year (September 1-August 31) age compositions in the base model, though preliminary effects of incorporation of the seasonal compositions on assessment model results were investigated. The resultant all-years pooled marginal age composition for red drum can be found in Figure 102, which clearly shows the majority of fish captured in the survey are age-1, with fewer age-0, age-2, age-3, and age-4+ fish encountered.

### **5.8.2 Trends**

Overall, the SCDNR electrofishing shows a stable, if fluctuating abundance of red drum through the early-2010s survey, before a steady decline to record low abundances in the late-2010s (Table 45 and Figure 103). However, there was a stark rebound in relative abundance indicated in the terminal year of the index, indicating the potential for a strong 2021-year class.

Annual length compositions available from the SCDNR electrofishing generally show a primary mode associated with age-1 red drum encountered by the survey (Figure 104), with most fishing years exhibiting a clear mode at approximately 40 cm. However, in most years the survey encounters red drum ranging in size from <10 cm to >70 cm (Figure 104). From the age compositions, we see that age-1 fish are numerically dominant in all years of the survey, though fish ranging in age from 0 to 4+ years old were observed in most years (Figure 105).

### **5.8.3 Potential Biases, Uncertainty, and Measures of Precision**

Overall, the SCDNR electrofishing survey exhibits low RSEs, with an average RSE of 0.096 (range: 0.087-0.12; Table 45). This is comparable to the uncertainty measures obtained from the SCDNR trammel net survey. In addition, the long time series (22 years) and clear age-1 abundance signal provides additional insight into the long-term trends in sub-adult red drum and recruitment along coastal South Carolina.

## **5.9 South Carolina Contemporary Longline Survey (SC\_Longline\_contemporary)**

### **5.9.1 Data Collection and Treatment**

To monitor populations of adult red drum in South Carolina's estuarine and coastal ocean waters, the SCDNR began sampling using longlines in Charleston Harbor in 1994. Though the contemporary SCDNR adult red drum and shark coastal longline survey (i.e., SCDNR longline survey) traces its roots to this original historic survey, the survey was less standardized in the early years and underwent a significant modification prior to the 2007 field season. In its contemporary form, the survey samples the mouths of four South Carolina estuaries, Port Royal Sound, St. Helena Sound, Charleston Harbor, and Winyah Bay, and nearshore live bottom habitat, with fixed stations found along the edge of deep channels and at known red drum aggregation sites (Figure 91). A primary focus of the survey is to develop an index of relative abundance of adult red drum to develop a better understanding of adult red drum populations along the southeastern Atlantic coast, thereby allowing for more effective and responsible management of the stock. Information from this survey has also been used for coastal shark assessments across the region.

The primary objectives of the survey are to conduct fishery-independent longline sampling on adult red drum and coastal sharks to generate information on CPUE for indices of abundance. The survey also collects biological information (size, sex, etc.) and samples (otoliths, gonads, muscle, fin clips, etc.) from random sub-samples of the red drum catch to determine size-at-age, recruitment to the spawning population, and genetic composition of the stock. Further, released adult red drum (and some sharks) are tagged to collect migration and stock identification data.

#### 5.9.1.1 Survey Methods

With the 2007 field season, the SCDNR longline survey was redesigned to employ a stratified random fixed station sampling design. The survey samples four strata (Port Royal Sound, St. Helena Sound, Charleston Harbor, and Winyah Bay; Figure 91) during each of three six-week sampling periods (1 = Aug 1-Sept 15, 2 = Sept. 16-Oct 31, and 3 = Nov 1-Dec 15). The number of available stations for random selection per strata varies from 43-81: Port Royal Sound (78), St. Helena Sound (81), Charleston Harbor (43), and Winyah Bay (51). From this pool of stations, thirty are randomly selected for sampling from each stratum during each 6-week period, for an expected 120 collections per six-week sampling period and 360 collections field season<sup>-1</sup>.

Traditionally, all sampling for the SCDNR longline survey has been conducted aboard the *R/V Silver Crescent* using standardized gear. The exception was the 2022 field season when due to vessel damage to the *R/V Silver Crescent* from a hurricane the survey was moved to a smaller platform, the *R/V Regulator*. Longline gear consists of a 610 m monofilament mainline (272 kg test) with weights ( $\geq 15$  kg) and a 30.5 m buoy line attached at each end. The mainline is equipped with stop sleeves every 30 m (21 line<sup>-1</sup>) to prevent gangions from sliding together when a large fish is captured. The terminal tackle (gangions) is constructed of 0.5 m, 91 kg test monofilament leader, size 120 stainless steel longline snap, 4/0 swivel, and a 15/0 non-stainless-steel Mustad circle hook. Longlines were baited with Atlantic mackerel (*Scomber scombrus*), half Atlantic mackerel and half striped mullet (*Mugil cephalus*) for a bait study in Charleston Harbor (2011/2012), or all striped mullet, with forty gangions placed on each mainline.

For each set, the station location (site nested in strata, latitude/longitude, and location (inshore vs. offshore)) and gear code is recorded. When setting the gear, a start time (gear fully deployed) and end time (gear retrieval begins) of the set is noted for calculation of a set time (duration), in minutes. Gear was only set during daylight hours, and soak times for longline sets were limited to 45 minutes unless conditions or events dictated otherwise. A beginning and end depth is recorded at each station. Water quality (salinity (PSU), dissolved oxygen (mg L<sup>-1</sup>), water temperature (°C), tidal stage) and environmental conditions (air temperature (°C), percent cloud cover, wind direction, and wind velocity) are recorded at the end of each set.

From 2007 to 2022, the SCDNR coastal longline survey made 5,965 collections along the South Carolina coastline, of which 5,137 were used in the construction of the red drum index of relative abundance (Table 46).

### 5.9.1.2 Biological Sampling

Staff bring each fish captured on the longline on board, where they remove the hook, measure each fish to the nearest mm FL (i.e., mid-line length) and TL, weigh each fish to the nearest gram, and retain a fin tissue sample for genetic analysis. At the conclusion of initial workup, staff tag and release each individual or sacrifice the individual for age estimation and reproductive assessment. Each red drum not sacrificed receives two tags unless previously tagged: a nylon dart tag (Hallprint©) inserted in the dorsal musculature near the mid-point of the second dorsal fin at an angle toward the head and embedded in between the pterigiophores, and a PIT tag, which is inserted in the dorsal musculature near the origin of the soft rayed dorsal fin (second dorsal).

Red drum sacrificed for additional life history studies were randomly selected, with every  $n^{\text{th}}$  ( $n$  varies depending on system, catches and year) fish encountered, up to a maximum of ten fish daily, sacrificed. Staff ascertain and retain additional biological variables from sacrificed adult red drum (~100 per year), including otoliths for age determination, gonad tissues for histological determination of reproductive status, and muscle tissues for contaminant analysis. A summary of the life history information provided to the benchmark assessment from the SCDNR contemporary longline survey is found in Table 33. Red drum sacrificed for age from the SCDNR coastal longline survey have exclusively been aged via otolith thin-section techniques.

### 5.9.1.3 Catch Estimation Methods

During SEDAR 44, the SCDNR longline survey was included as an age-aggregated index of red drum abundance in the final assessment model, though steps were taken to allow combining of the historical data with the contemporary data stream. This included only using data collected at the Charleston Harbor “index” sites routinely sampled during the historical period, which allowed for the construction of a longer time series at the expense of discarding most contemporary data collected since 2007. The desire for combining the two timeseries was driven by the short length of the contemporary survey during the SEDAR 44 benchmark assessment. In addition, an *ad hoc*, external correction factor was applied to account for bait type effects on the nominal index developed (SEDAR 2015a). However, at the time they noted the RSEs of the survey were low, the combined index provided a long time series of adult relative abundance, and that the survey was the only information on abundance of mature, adult fish from the southern stock. Herein, the SAS decided to continue pursuing the use of the age-aggregated contemporary longline survey, with standardization techniques to account for the effect of bait type, instead of an *ad hoc* external correction, and other covariates affecting catchability.

Using only catch data on red drum collected during the months of August through December, the relative abundance index was standardized to account for the impact covariates (Discrete: fishing year (2007-2022), stratum, stratum by fishing year interaction, and bait type; Continuous: day of year (1/1 = day 1), water depth (m), water temperature (°C), and salinity (PSU); Random: site) had on collection level catchability of red drum. The inclusion of the “site” level random effect led to the investigation of a best fit model using either a NB GAM or NB

GAMM framework with fishing year as the primary variable of interest. Data was filtered to only retain fixed stations (e.g., “sites”) where we had captured red drum throughout the history of the survey. The number of hooks was included as an offset term in the considered NB GAM and NB GAMM models to account for difference in effort, with the best fit model chosen based on BIC. Continuous covariates were fit using a smoother using a cubic regression spline smoothing basis (Wood 2011; Wood 2017). In NB GAMM models, the site random effect was fit using a smoother using a ridge penalty which is equivalent to an assumption that the coefficients are independent and identically distributed random effects (Wood 2008). Through investigation of all combinations of considered covariates, BIC selected the best fit NB GAM model,

$$Catch = Year + Stratum + Bait Type + s(Water Temperature, bs = 'cr') + s(Day of Year, bs = 'cr') + offset(\ln(hooks)) + 1.$$

Fishing year effects were estimated using the best fit model using estimated marginal means using the *emmeans* package in R (Lenth 2023).

Annual length compositions for the survey were developed from the observed TL measurements made on all individuals encountered by the survey. There was no need for expansion of the length compositions given the survey sampling design. Compositions were developed using 2 cm length bins (e.g., 0-19 mm TL = 0 cm bin, 20-39 mm TL = 3 cm bin, etc.). The all-years pooled length composition for the survey can be found in Figure 106. Note, owing to the slowing of growth in adult red drum captured by this survey, there is little structure in the length composition to inform year class strength.

Age compositions for the survey were developed using paired TL and age measurements made on all individuals encountered by the survey. While annual age compositions for the survey were directly available due to the random age-sampling design employed by the SCDNR contemporary longline survey, we also used proportional odds logistic regression to develop annual age-length keys (ALK) conditional on the model

$$Age = a * TL + b * Year + c,$$

where *Age* is an ordered (smallest to largest) observed integer, biological age based on otolith or length derived age estimates, *TL* is a 2-cm TL bin (see length compositions) and *Year* represents the fishing year of capture (Agresti 2002; Ogle 2018; Stari et al. 2010; Venables & Ripley 2002), to develop marginal age compositions. The resultant best fit model was used to determine the biological age of all un-aged red drum captured from the contemporary longline survey for which a TL (and hence TL bin) was available. These smoothed ALK “aged” fish were then added to the fish directly aged to develop marginal age compositions for each fishing year. Note, however, that use of the smoothed ALK developed from the proportional odds logistic regression model led to less distinct year class signals in the marginal age compositions, with the benefit of providing a more robust age composition sample size as all un-aged fish were assigned a biological age.

The resultant all-years pooled marginal age composition, based on raw biological ages from the selected fish and the employment of the proportional odds logistic regression model, for red drum can be found in Figure 107. While the effect of the smoothed ALK does not appear to significantly affect the across years pooled age composition, it has a larger effect on apparent year class strength (Figure 108). While the expanded marginal age composition using the smoothed ALK shows the same general distribution of year classes, the magnitude of differences in individual year classes is muted relative to the raw marginal age compositions. In particular, the raw marginal age compositions hint at strong 1973-1974-, 1978-, 1984-, 1986-, 1990-, 2000-, 2001-, and 2006-year classes being captured by the contemporary longline survey. Signals of the strong 1991-, 2000-, 2001-, and 2006-year classes are also observed in the annual SCDNR trammel net marginal age compositions (Figure 96).

In the stock synthesis framework, the model can also utilize conditional age-at-length information where information on aged fish in length bins (i.e., raw ALK) by year and survey can be directly incorporated into the model to inform selectivity, growth, and natural mortality. To facilitate the incorporation of conditional age-at-length information from the SCDNR contemporary longline survey, raw age and length information was provided to the benchmark assessment.

### **5.9.2 Trends**

Overall, the survey suggests a stable to decreasing abundance of red drum along coastal South Carolina since 2007 (Table 47, Figure 107), with particularly low predicted adult abundance in 2010-2011 and 2021-2022. Outside of these years, the only other year deviating from the long-term average is 2009, which suggested higher red drum abundance than the rest of the time series (Figure 109).

Annual length- and age-compositions available from the SCDNR contemporary longline survey have more difficulty tracking individual cohorts of red drum encountered by the survey, which is not surprising given the size range and age-classes of adult red drum this survey intercepts (Figure 110 - Figure 112). Concerning is the decrease in the relative proportion of older fish in the longline survey since the mid-2010s (Figure 111), particularly given the declining numbers of sub-adult red drum encountered by the SCDNR trammel net survey (Figure 94). Further, there are indications that one can track strong year classes through the annual age compositions, particularly when using the raw annual marginal age compositions using fish randomly selected for sacrifice by the survey. This is particularly evident when tracking the 2000-year class in the years 2007, 2010, 2012, 2015, 2018-2020, and 2022 (Figure 111 - Figure 112); this year class likely was not observed in other years due to relatively limited sample size for aged fish.

### **5.9.3 Potential Biases, Uncertainty, and Measures of Precision**

Overall, the SCDNR contemporary longline survey exhibits moderate RSEs, with an average RSE of 0.20 (range: 0.17-0.28; Table 47). However, less effort in the 2007-2009 sampling seasons translates to increased uncertainty during this time block. Further, the effect of bait type on the



catchability of red drum introduces an additional source of uncertainty to annual estimates of relative abundance. As Atlantic mackerel was used exclusively in 2007-2009 and striped mullet from 2010-2019, this leads to caution when interpreting the CPUE across these years. However, a bait study conducted in Charleston Harbor in 2011 and 2012 allows analysts to develop correction factors (SEDAR 2015a; Murphy 2017) to minimize the impact bait type has on annual CPUE and the effect of bait type was directly incorporated into the standardization model herein. Further, this time series is growing in length, with the anticipation that the increased survey length will improve our understanding of abundance changes in the adult population that may manifest slowly as the survey integrates data over many age classes.

## **5.10 Georgia Gill Net Survey (GA\_GillNet)**

### **5.10.1 Data Collection and Treatment**

To determine red drum relative abundance, the gill net survey was conducted in Altamaha and Wassaw Sounds (Figure 113) from June through August 2003-2023.

#### **5.10.1.1 Survey Methods**

In the Altamaha River Region (Figure 114), 36 stations were sampled each month (June – August) from a pool of 60 total stations using a stratified random station design. In a given survey month, each selected station is sampled one time. In Wassaw Sound (Figure 115), 36 stations were selected and sampled from a pool of 70 total stations using a stratified random station design. The time series covers 2003-present.

All sampling occurred during the last three hours of ebb tide and only during daylight hours. Station pools in both survey areas were determined by initial surveys, which identified locations that could be effectively sampled with survey gear.

Survey gear is a single panel gillnet. The net is 91.4 m (300 ft) long by 2.7 m (9 ft) deep. The panel has 6.4 cm (2.5 in) stretch mesh. The net has a 1.3 cm (0.5 in) diameter float rope and a 34 kg (75 lb) lead line. A 11.3 kg (25 lb) anchor chain is attached to each end of the lead line, and a large orange bullet float is attached to each end of the float line.

A sampling event consists of a single net set. The net is deployed by boat starting at the bank following a semicircular path and ending back on the same bank. Net deployment is performed against the tidal current. Immediately after deployment, the net is actively fished by making two to three passes with the boat in the area enclosed by the net. After the last pass is made, the net is retrieved starting with the end that was first set out. As the net is retrieved, catch is removed and put inside a holding pen tied to the side of the boat. After the net is fully retrieved, all catch is processed for information and released. The catch is identified to species and counted. In addition to catch information, temporal, spatial, weather, hydrographic and physio-chemical data are collected during each sampling event.

#### **5.10.1.2 Biological Sampling**

All finfish specimens are measured to the nearest mm FL.

### 5.10.1.3 Catch Estimation Methods

Catches of target species were first separated into age cohorts by applying a standard monthly cutoff value to the length frequency information collected with each catch. Cutoff values vary among months for each species and were based on modal analyses of historical composite monthly length frequency data and reviews of ageing studies for each species. For the earlier months of the year, cutoff values were arbitrary values that fell in between discrete modal size ranges. In the later part of the year, when early spawned, rapidly growing individuals of the most recent year class may overtake late spawned and slowly growing individuals of the previous year class, cutoff values were selected to preserve the correct numeric proportionality between year classes despite the misclassification of individuals.

The extent of the zone of overlapping lengths and the proportion within that range attributable to each year class is estimated based on the shape of each modal curve during the months prior to overlap occurring. A length value is then selected from within that range which will result in the appropriate proportional separation. In the case of red drum, specimens collected during the survey most often represented age-1 fish, with 97% of all fish captured falling in the 220 to 350 mm range. Although this process involved considerable subjectivity and ignored possible interannual variability in average growth rates, there was little likelihood that any significant error was introduced as only a very small fraction of the specific aged cohort individuals fell within the zone of overlap. Most of the data used to construct juvenile indices were drawn from months when no overlap at all is present. Given the short sampling period of the gillnet sampling (June-August), all three months were used in these estimates.

Survey catch rate data were standardized in a model-based approach to account for variables affecting catchability. Net dimensions changed from a depth of six feet to nine feet in 2004, but the biologists on the survey indicated this change was unlikely to affect catchability because red drum are caught in the portions of the net unaffected by the change (i.e., net ends in one-three feet of water). Therefore, the entire time series of data was used for an index. Approximately forty five percent of the net sets observed positive red drum catches throughout the time series.

After checking available variables for collinearity and adequate sample sizes by level for categorical variables, variables selected for the standardization included depth, sound system, salinity, water temperature, dissolved oxygen, wind velocity, habitat type, and month. Year was retained to calculate the year effect (i.e., the annual index) and red drum catch per net set was used as the response variable.

A series of model types with negative binomial distributions including GLMs, GAMs, zero-inflated GLMs, and zero-altered GLMs were explored. GLMs and GAMs include one model component modeling the expected catch rates, while zero-inflated and zero-altered GLMs include second model components with binomial distributions modeling the probability of zero and non-zero (positive) catches. Model selection was made through evaluation of model fits for lack of overdispersion, evaluation of residual diagnostics for lack of residual patterns, and AIC comparisons. If a more parsimonious model was within two AIC units of the model with the

lowest AIC, the more parsimonious model was selected. Model selection started with comparison of model types using the full set of variables and indicated the zero-altered GLMs performed best. Zero-altered GLMs were then evaluated with the full set of variables and reduced sets of variables for both components of the models. Model selection criteria favored a final model with year, depth, sound system, salinity, habitat type, and month for the catch rate component and year, sound system, water temperature, wind velocity, habitat type, and month for the zero-inflation component.

The standardized index was calculated by extracting model-predicted year effects for each year while holding other variables in the model constant across years.

### **5.10.2 Trends**

The trend is stable through 2009, declines to lower levels in the early 2010s, and then increases back to levels observed prior to 2010 for most of the late 2010s and 2020s (Figure 116). The index increased to the highest observed value in the final fishing year of 2022.

One thing to keep in mind is that the gill net survey is designed to target juvenile red drum and the average size of fish caught in the survey is 282 mm FL. Essentially this survey is a measure of annual recruitment and is largely driven by spawning success and environmental effects on larval/juvenile fish survivability through the winter/spring. The index generally tracks well with annual MRIP estimates.

### **5.10.3 Potential Biases, Uncertainty, and Measures of Precision**

The final model was used in a bootstrapping analysis with 1,000 replicates to generate standard errors, SEs, and confidence intervals for the standardized index.

SEs are stable and vary slightly around an average of 0.21 throughout the time series (Table 31). The index with confidence intervals is shown in Figure 116.

Overall, the GA gillnet survey is a robust long-term standardized survey, designed specifically to target YOY red drum before they enter the fishery. The survey has been in continuous operation since 2003 and the survey design has remained relatively unchanged since its inception. Geographically the survey has historically included two primary regions (Wassaw and Altamaha). Recognizing that this could lead to an underrepresentation of statewide red drum trends, a third system (St. Andrew) was added in 2019. Data from the St. Andrew expansion is still preliminary and has not yet been included in the survey index. However, the addition of St. Andrew and any other future expansions should help improve statewide status estimates.

## **5.11 Georgia Longline Survey (GA\_Longline)**

### **5.11.1 Data Collection and Treatment**

The GADNR utilizes a near shore red drum bottom longline survey which encompasses state and federal waters off the coast of Georgia. This is a stratified-random study to develop fishery-

independent indices of abundance for multiple shark species and adult red drum occurring in state waters. Data gathered from this study is used to support long-term fishery-independent indices useful for assessing stock status and trends. Tagging of red drum and sharks captured during the study allows for additional information on migratory behavior and stock identification to be collected.

Since its inception in 2006, Georgia's longline survey has captured over 900 large, adult red drum (870 in Georgia waters), with 777 of those occurring in the months of September – December. For this assessment, Georgia's Longline CPUE was constrained to catch of red drum that only occurred in Georgia waters during the months of September – December to standardize the CPUE to that of other similar surveys throughout the region (SC & NC).

#### **5.11.1.1 Survey Methods**

Current sampling occurs in waters of Doboy Sound to St. Marys in Georgia from June to December. Stations are randomly chosen from a subset of sites identified as areas with high encounter probabilities. Three strata are delineated off Georgia (inshore; near shore; offshore) and sampling efforts are proportionally allocated to match the emigration pattern of adult red drum. All stations are sampled during daylight hours and are generally located in water depths between 13 and 65 feet. The longline is deployed from the *R/V Glynn*, a 47' offshore vessel. The mainline is made of 2.5 mm monofilament and is approx. 926 m in length. A total of 60 droplines are attached to the mainline, where each dropline consists of a longline snap, 1.5 ft of 200 lb. monofilament, and a 12/0 circle hook on the terminal end. Hooks are not offset and have barbs depressed. The total soak time is 30 minutes with hooks baited with mullet.

Beginning in 2018, sampling was broken up into 4, 6-week quarters. A minimum of 35 bottom-set longline stations are selected to be sampled in Georgia coastal waters each 6-week quarter (June 16 – July 31, Aug 1 – Sep 15, Sep 16 – Oct 31, Nov 1 – Dec 15).

#### **5.11.1.2 Biological Sampling**

All catch is processed at the species level. All red drum are landed and processed for standard morphometrics and genetic material (fin clip) when requested. Viable red drum are tagged with conventional dart and PIT tags and released. Mortalities are processed further for sex and gonadal development information, and otoliths are extracted for age determination. Periodically, a subsample of red drum may be sacrificed to estimate the adult stock age composition.

#### **5.11.1.3 Catch Estimation Methods**

For this assessment, to standardize CPUE to similar surveys in the region (SC & NC), Georgia's Longline index was constrained to catch that only occurred in Georgia waters in the months of September – December.

Survey catch rate data were standardized in a model-based approach to account for variables affecting catchability. There were only seven sets in 2020, so this year of data was dropped

from the data set. Approximately twenty five percent of the sets observed positive red drum catches throughout the time series.

After checking available variables for collinearity and adequate sample sizes by level for categorical variables, variables selected for the standardization included strata, water temperature, and weather conditions. Year was retained to calculate the year effect (i.e., the annual index) and red drum catch per set was used as the response variable.

The same approach for model exploration and selection as that described for the Georgia Gill Net Survey was used for this longline survey. Model selection started with comparison of model types using the full set of variables and indicated the zero-inflated GLMs performed best. Zero-inflated GLMs were then evaluated with the full set of variables and reduced sets of variables for both components of the models. Model selection criteria favored a final model with year, strata, and water temperature for the catch rate component and strata and water temperature for the zero-inflation component.

The standardized index was calculated by extracting model-predicted year effects for each year while holding other variables in the model constant across years.

#### **5.11.2 Trends**

The trend shows a slight increase throughout the time series (Figure 117).

The length compositions of red drum caught during the survey are in Figure 118.

#### **5.11.3 Potential Biases, Uncertainty, and Measures of Precision**

The final model was used in a bootstrapping analysis with 1,000 replicates to generate standard errors, SEs, and confidence intervals for the standardized index.

SEs follow a slight decreasing trend through time with an average of 0.31 across years (Table 31). The index with confidence intervals is shown in Figure 117.

In the early years of the survey different hook sizes and bait types were tested. In 2006 mackerel was the only bait type and a 15/0 hook was the only size hook used. In 2007, both mackerel and squid were the bait types used with a 15/0 hook. From 2008-2015 a combination of hook sizes was tested with squid only as bait. During that period, 50% of hooks were size 15/0 and 50% were size 12/0. From 2016-2020 mullet and squid were tested with size 15/0 hooks only. In 2020, vessel availability due to mechanical problems limited sampling activities. Beginning in 2021 the survey was tuned to replicate the South Carolina longline survey which included standardized hook size (15/0) and bait selection (mullet; Table 48)

## **5.12 Florida 21.3 Meter Haul Seine Survey (FL\_21.3\_HaulSeine)**

### **5.12.1 Data Collection and Treatment**

Indices of relative abundance for red drum were derived from surveys conducted by the Florida Fish and Wildlife Research Institute's Fishery Independent Monitoring (FIM) program in northeast Florida (lower St. Johns, Nassau, and St. Mary's River basins). Data from the northern portion of the Indian River Lagoon were initially considered, but were excluded from index development by the data workshop panel. The rivers and estuaries of northeast Florida are dominated by salt marshes and more closely resemble the estuaries and riverine systems of coastal South Carolina and Georgia (i.e., the rest of the southern region for red drum). In contrast, the Indian River Lagoon can be characterized as a broad transitional zone dominated by mangrove wetlands.

The 21.3-m center bag seine was used to develop an index of relative abundance for age-0 YOY red drum.

#### **5.12.1.1 Survey Methods**

The FIM program uses a stratified random sampling design to monitor abundances of fish and invertebrates. Survey areas were divided into sampling zones based upon geographic and logistical criteria where each zone was further subdivided into 1-nm<sup>2</sup> grids and randomly selected for sampling. Sampling grids were stratified by depth and habitat (defined by shore type [overhanging or not] and bottom vegetation [vegetated or not]) where a single sample was collected at each randomly selected site in shallow water  $\leq 1.8$  m. Environmental data consisting of water chemistry, habitat characteristics, and current and tidal conditions were recorded for each sample. In northeast Florida, sampling has been conducted year-round since May 2001.

#### **5.12.1.2 Biological Sampling**

All captured red drum were counted and a random sample of at least 20 individuals were measured in standard length (SL). If more than 20 red drum were encountered, then length frequencies of the 20 fish were expanded to the total number caught to estimate the sample catch length frequency.

#### **5.12.1.3 Catch Estimation Methods**

YOY were defined as red drum captured during the peak recruitment season of September through March and whose lengths were smaller than or equal to 40 mm SL. Cohorts were kept together such that fish caught in September through December were grouped with those caught January through March the following year. Prior to standardization, the data were subset to remove any months, zones, or strata that rarely encountered red drum.

Catch rates for this index were standardized using the delta lognormal model which split the process into two generalized linear sub-models (Lo et al. 1992). The first sub-model estimated the proportion of stations where red drum were observed. This sub-model used a binomial

distribution with a logit link. A separate sub-model with a gamma distribution and a log link was used to estimate the mean number of red drum caught at positive stations. The estimated coefficients were then back-calculated from their linearized form used in the modeling steps. The annual index is the product of the proportion of samples where red drum were observed and the mean number of red drum by year estimated from the positive model.

Potential explanatory variables included year, month, bottom vegetation, bottom type, shore type, bay zone, water temperature (°C), dissolved oxygen (mg/L), and salinity (ppt). All potential explanatory variables were treated as categorical variables partially to account for non-linearity. Beginning with the null model, forward stepwise selection was used to identify which variables should be included in the final versions of the sub-models. To be included in the final sub-model, variables had to meet two criteria: the variable must be statistically significant at an alpha level of 0.05 and its inclusion must reduce deviance (a measure of the variability) by at least 0.5%.

### **5.12.2 Trends**

The YOY index of relative abundance for red drum was variable but stable around a mean through 2011 with a strong year class in 2012. Abundance then decreased and became variable around a lower mean from 2013 through 2022 with another strong year class in 2021 (Table 31 and Figure 119). Weak year classes occurred in 2005, 2010, and 2018. Data for the 2022 fishing year were not available for the assessment.

### **5.12.3 Potential Biases, Uncertainty, and Measures of Precision**

To estimate variability in the annual index values (Table 31), a Monte Carlo simulation approach was used with 10,000 iterations using the least-squares mean estimates and their standard errors from the two generalized linear sub-models. Each iteration used the annual least-squares mean estimate on the log scale and uncertainty was added by multiplying the annual least-squares mean estimate's standard error by a random normal deviate ( $\mu=0$ ,  $s=1$ ). These values were transformed back from their linear scales prior to being multiplied together and the index derived was the product of the probability of observing a red drum during sampling and the annual average number of red drum counted at sites where this species was encountered.

## **5.13 Florida 183 Meter Haul Seine Survey (FL\_183\_HaulSeine)**

### **5.13.1 Data Collection and Treatment**

Indices of relative abundance for red drum were derived from surveys conducted by the Florida Fish and Wildlife Research Institute's Fishery Independent Monitoring (FIM) program in northeast Florida (lower St. Johns, Nassau, and St. Mary's River basins). As stated above, data from the northern and southern portions of the Indian River Lagoon were initially considered, but were excluded from index development by the data workshop panel.

The 183-m haul seine was used to develop an index of relative abundance for sub-adult red drum.

#### **5.13.1.1 Survey Methods**

The FIM program uses a stratified random sampling design to monitor abundances of fish and invertebrates. Survey areas were divided into sampling zones based upon geographic and logistical criteria where each zone was further subdivided into 1-nm<sup>2</sup> grids and randomly selected for sampling. Sampling grids were stratified by depth and habitat (defined by shore type [overhanging or not] and bottom vegetation [vegetated or not]) where a single sample was collected at each randomly selected site in shallow water  $\leq 1.8$  m.

Environmental data consisting of water chemistry, habitat characteristics, and current and tidal conditions were recorded for each sample. In northeast Florida, sampling has been conducted year-round since May 2001.

#### **5.13.1.2 Biological Sampling**

All captured red drum were counted and measured (SL). If five or fewer were captured within a single set, they were culled for further biological sampling including weight, sex, maturity, age, mercury content, and diet.

Red drum culled for further biological sampling had their otoliths removed and aged by FWRI's Age and Growth lab.

#### **5.13.1.3 Catch Estimation Methods**

Sub-adults were defined as red drum captured year-round whose lengths were larger than 180 mm SL. Prior to standardization, the data were subset to remove any months, zones, or strata that rarely encountered red drum.

Catch rates for this index were similarly standardized as the 21.3-m seine index using the delta lognormal model which split the process into two generalized linear sub-models (Lo et al. 1992). The first sub-model estimated the proportion of stations where red drum were observed. This sub-model used a binomial distribution with a logit link. A separate sub-model with a gamma distribution and a log link was used to estimate the mean number of red drum caught at positive stations. The estimated coefficients were then back-calculated from their linearized form used in the modeling steps. The annual index is the product of the proportion of samples where red drum were observed and the mean number of red drum by year estimated from the positive model.

Potential explanatory variables included year, month, bottom vegetation, bottom type, shore type, bay zone, water temperature (°C), dissolved oxygen (mg/L), and salinity (ppt). All potential explanatory variables were treated as categorical variables partially to account for non-linearity. Beginning with the null model, forward stepwise selection was used to identify which variables should be included in the final versions of the sub-models. To be included in the final sub-model, variables had to meet two criteria: the variable must be statistically significant at an alpha level of 0.05 and its inclusion must reduce deviance (a measure of the variability) by at least 0.5%.



### 5.13.2 Trends

The sub-adult index of relative abundance for red drum largely following a similar trend to the YOY index where abundance was variable through 2012 with high abundances in 2003, 2005, and 2009. Abundance was then low from 2013 – 2020, then increased again in 2021 (Table 31 and Figure 120). Data for the 2022 fishing year were not available for the assessment.

The survey primarily encountered subadult red drum living in the estuaries and rivers who recruited out of the 21.3 m seine as older age-0 fish through age 4 (Figure 122).

### 5.13.3 Potential Biases, Uncertainty, and Measures of Precision

To estimate variability in the annual index values, a Monte Carlo simulation approach was used with 10,000 iterations using the least-squares mean estimates and their standard errors from the two generalized linear sub-models. Each iteration used the annual least-squares mean estimate on the log scale and uncertainty was added by multiplying the annual least-squares mean estimate's standard error by a random normal deviate ( $\mu=0$ ,  $s=1$ ). These values were transformed back from their linear scales prior to being multiplied together and the index derived was the product of the probability of observing a red drum during sampling and the annual average number of red drum counted at sites where this species was encountered.

## 6 METHODS

Several analyses were developed through the course of this assessment. The primary analyses at the beginning of the assessment were the SS models and TLAs recommended during the simulation assessment. Additionally, a tagging model was developed with South Carolina tagging data as a complementary analysis providing mortality trends and to better utilize tag-recapture data available for the assessment, a recommendation of past SASs and RPs. Later on in the assessment, a data-limited method, Skate, was developed as a backup method in the case that stable SS models could not be developed to provide catch advice. The TLAs do not provide quantitative catch advice and are intended to be complementary analyses that provide qualitative stock status information.

### 6.1 Cormack-Jolly-Seber Tagging Model

#### 6.1.1 Background

The Cormack-Jolly-Seber (CJS) model is a standard tagging model used to estimate mortality rates from live encounter data of an open population experiencing births, deaths, and migration (Lebreton et al. 1992; Pollock et al. 1990). The CJS model uses forward-time modeling to estimate two key parameters: apparent survival ( $\Phi$  – the probability that an animal survives, including losses due to mortality and permanent emigration) corrected for the probability of encounter ( $p$  – the probability an animal is detected given it is available for encounter in the study area; Sandercock et al. 2020). For a sample consisting of  $n$  occasions, the CJS model calculates  $n-1$  estimates of  $\Phi$  and  $n-2$  estimates of  $p$ , whereby the apparent survival is estimated between occasions and encounter probabilities are estimated for each sampling

occasion. Importantly, this means encounter rates cannot be estimated for the first sampling occasion, and these two parameters are confounded on the last sampling occasion, only allowing for estimation of the product of the two parameters ( $\beta$ ). The CJS model requires capture histories from at least three sampling occasions and can be fit using a multinomial maximum likelihood estimation (Lebreton et al. 1992).

Model structure illustration:

$$\begin{array}{ccccc} 1 & \phi_1 & 2 & \phi_2 & 3 \\ & \rightarrow & & \rightarrow & \\ & & p_2 & & \beta_3 \end{array}$$

Encounter histories and corresponding probability statements:

Encounter history	probability
111	$\Phi_1 p_2 \beta_3$
110	$\Phi_1 p_2 (1 - \beta_3)$
101	$\Phi_1 (1 - p_2) \beta_3$
100	$1 - \Phi_1 p_2 - \Phi_1 (1 - p_2) \beta_3$

CJS model assumptions (Pollock et al. 1990) include:

1. Every marked animal in the population at sampling period  $i$  has the same probability of capture,
2. Every marked animal in the population at sampling time  $i$  has the same probability of survival until the next sampling period ( $i+1$ ),
3. Marks are not lost, overlooked, or mis-recorded,
4. Sampling periods are instantaneous, and releases are made immediately following sampling.

### 6.1.2 Data

Red drum were tagged as part of ongoing SCDNR fisheries-independent monitoring programs using a combination of SC\_Trammel (1990-present), SC\_Electro (2001-present), and SC\_Longline\_contemporary (2007-present) surveys. For a full description of the SCDNR tagging program and related protocols, please see Section 4.3 and Arnott et al. (2010). Sampling occurred along the South Carolina coast on a monthly basis throughout the year, but data were restricted to only include releases and recaptures from September – December (to satisfy assumption #4 above). Furthermore, tagging data were only examined from 1990-2022, with 2021 being the last year of releases considered. In addition, any fish eventually harvested or released without a tag after the initial release were omitted from analyses.

Due to potential heterogeneity in survival rates across fish ages, red drum were assigned age classes (1-3+) based on seasonal (monthly) age-length-keys developed by the SCDNR Inshore Fisheries Research Section.

### 6.1.3 Model specification and selection

All analyses were performed in the R Core environment (R Core Team 2021). Individual fish capture histories were generated using the 'capHistConvert' function in the 'FSA' package (Ogle et al. 2023). Prior to model analyses, goodness of fit (GOF) tests were performed on the data using the 'overall\_CJS' function in the 'R2ucare' package (Gimenez et al. 2018). Following the package author's recommendations, the data were first segmented by group (age) before overall\_CJS test were run. The overall\_CJS function aims at testing with contingency tables (and Fisher's exact test if needed) for the presence of transients (Pradel et al. 1997, 2003) and trap-dependence (Pradel 1993; Pradel et al. 2003). The result of this test suggested no such impacts of either effect were likely for any age group (Age 1 -  $\chi^2 = 40.879$ ,  $df=75$ ,  $p = 1.0$ ; Age 2 -  $\chi^2 = 50.556$ ,  $df = 69$ ,  $p = 0.9$ ; Age 3 -  $\chi^2 = 41.215$ ,  $df=49$ ,  $p = 0.8$ ). Accordingly, and following the package author's recommendation, we fit the data to a standard CJS model (Gimenez et al. 2018).

The CJS candidate models were generated using the R package 'marked' (Laake et al. 2013). Twenty-five candidate models were generated (Table 49). Estimated annual apparent survival probability was allowed to either be constant ( $\sim 1$ ), vary by age group, time, age group + time, or age group \* time. Similarly, encounter probability was modeled as either constant ( $\sim 1$ ), varying by age group, or by the varying survey initiating periods (1990-2000, 2001-2006, 2007-2022), as well as the additive effects of age group and survey period (age + period) and their interaction (age \* period). Of these candidate models, the 'best' model was selected based on the lowest AIC value. To aid in visualization of model results, if time was included as a predictor variable for  $\Phi$ , this term was smoothed using the 'bs' spline function in the 'splines' package (R Core Team 2024).

### 6.1.4 Results

A total of 24,555 red drum were released as a part of the SCDNR tagging program (with the above described data filtering processes), with 638 individuals recaptured at least once in subsequent years. The majority ( $n=609$ ) of recaptures occurred within two years of release or less, however, recaptures up to 13 years following initial release were observed. The most parsimonious model based on AIC modeled annual apparent survival as an interaction between the factors age and time (age \* time), with encounter probability being a function of an interaction between age and period (age \* period; Table 49). However, the resulting confidence interval around parameter estimates were large (e.g., ranging from 0.0-1.0 in certain years). This coupled with the relatively low difference in delta AIC of next 'best' candidate model (delta AIC = 1), led to selecting the best model as  $\Phi$  being a function of age+time, with  $p$  being a function of age group (Table 49). Using this model, trends in annual apparent survival are similar between age groups 2 and 3+, with age 1 having slightly higher annual apparent survival (possibly due to increased losses due to permanent emigration with the older age groups). For

all age groups, apparent survival trends displayed a unimodal pattern, peaking in the late 1990s through mid-2000s (Figure 123). Following this peak of approximately 0.4 (age 1) and 0.35 (ages 2 & 3+), annual apparent survival for all ages appears to be experiencing steady declines since 2010, returning to levels akin to those observed in the early 1990s by 2022 (Figure 123).

## 6.2 Stock Synthesis Models

### 6.2.1 Background

#### General Model Configuration

Population dynamics models were developed in SS version 3.30. Further descriptions of SS options, equations, and algorithms can be found in the SS user's manual (Methot et al. 2023), the SS GitHub repository (<https://github.com/nmfs-stock-synthesis/nmfs-stock-synthesis.github.io>), and Methot and Wetzel (2013). The r4ss R package (<https://r4ss.github.io/r4ss/>) was also utilized extensively to develop various graphics and summarize model outputs.

In SS, four input files are required: a starter file containing filenames and details about output reporting, a data file containing model dimensions and the data, a control file specifying model parameterization and set-up, and a forecast file containing specifications for reference points and forecasts (Methot et al. 2023). Model code is available at the SS GitHub repository.

Prior to developing the SS models in this assessment, work was done to address the simulation assessment peer review panel's recommendation to determine if the southern SS EM can produce unbiased estimates while using data without observation error (Section 1.3.2).

Briefly, during the simulation assessment review workshop time and resources were available to build a base scenario southern SS EM which continued to be configured with misspecified growth (i.e., a traditional von Bertalanffy) and a fixed natural mortality-at-age vector based on that growth, but used data without observation error. This created an improvement to the relative error, however, three-year F ratio estimates for the earlier part of the time series were very positively biased (see Figure 2 of ASMFC 2022).

At the beginning of this assessment, the impact of misspecified growth and mortality was investigated in greater detail. In the southern SS EM under the base scenario and of the 100 data iterations modeled, we identified the iteration with the lowest total log-likelihood, indicating the best model fit. Next, we took the corresponding iteration number produced by the southern SS OM, but where data was without observation error, and fit the southern SS EM to it. Improvements to the biases in relative error were seen in the three-year F ratio estimates, mature female number estimates, and the subadult number estimates (Figure 124). Since the goal of this analysis was to see if the southern SS EM could produce unbiased estimates, the EM was further configured so that growth and natural mortality matched the configuration of the OM and parameter values were fixed. As hoped, relative error was further improved as the EM was able to produce relatively unbiased estimates with no trend (Figure 124).

Following this work to confirm the southern model could produce unbiased estimates while using data without observation error, models were developed for this assessment by first using the model files from the simulation assessment while replacing simulated data with *in situ* data gathered during this assessment. These files were then modified throughout model development resulting in some differences from the simulation assessment and between stocks within this assessment. The general model configuration is described in the following section, followed by stock-specific model configuration details and data inputs.

The models were structured as length- and age-structured models that project the stock forward through time and track stock dynamics at an annual time step across length bins and age bins according to conversions from an internal growth model. Initial conditions are estimated based on (1) estimated initial F levels to reduce the unfished biomass level to that in the model start year and (2) estimated deviations to the equilibrium age structure as informed by early year class data in the start of the model.

Length bins were set at 2 cm intervals starting at 10 cm and 12 cm for the northern and southern stocks, respectively, out to the largest bin observed in each stock. All length inputs were in TL, either observed or converted using stock-specific relationships estimated with available data (Table 50). Similarly, ages were tracked starting at age-0 through the maximum age observed in each stock (62 for the northern stock, 41 for the southern stock) which acted as an accumulator age. The annual time step used was a fishing year from September of calendar year  $y$  through August of calendar year  $y+1$ . Spawning occurs in September at the beginning of the fishing year. The model does not differentiate between sexes, except in calculation of spawning stock biomass which is females only according to a 1:1 sex ratio. Modeled time series are from 1981-2022. Some 2022 fishing year data were not available or were preliminary, so this year was included in the model as an anchor for the 2021 fishing year estimates and is not used for stock status determination.

Life history parameters include age-specific  $K$  growth model parameters, Lorenzen (2005) length-based natural mortality-at-age, length-weight relationship parameters, female maturity-at-age, and stock-recruit relationship parameters (Table 51). Ages at which  $K$  was allowed to vary were specified according to the external age-specific  $K$  growth models described in Section 2.3. The Lorenzen natural mortality-at-age is calculated internally for ages 0-1 and 3-maximum age from a parameter describing natural mortality for age-2 fish. A Beverton-Holt stock-recruit relationship is used and includes parameters for unfished recruitment ( $RO$ ), steepness ( $h$ ), and variation around the expected stock-recruit relationship ( $\sigma R$ ) controlling magnitude of estimated annual recruitment deviations. Female spawning stock biomass (SSB) calculated from the maturity ogive and length-weight relationship parameters is the measure of reproductive potential used in the stock-recruit relationship.

Growth parameters (with the exception of the Length at Amin parameter in the northern stock model) and the unfished recruitment parameters for the stock-recruit relationship were estimated, while the other parameters were fixed inputs. The fixed age-2 natural mortality parameters were calculated externally using the external age-specific  $K$  growth model

estimates and the Lorenzen (2022) length-inverse model (Section 2.5). Exploration of the Lorenzen (2005) method used in SS was conducted on the southern stock model during the assessment workshops and found to produce values across ages similar to those produced by the Lorenzen (2022) model. Length-weight relationship parameters and female maturity-at-age were estimated from available data during this assessment (Section 2.4.2). Steepness of the stock-recruit relationship was fixed at 0.99 as recommended during the peer review of the simulation assessment (ASMFC 2022). This essentially reduces the stock recruit-relationship to a constant relationship between varying levels of SSB and average recruitment of the modeled time series, with annual deviations from this deterministic relationship estimated in the model. *Sigma R* is generally not estimable and was fixed based on tuning guidance from the r4ss package as recommended in the SS manual (Methot et al. 2023). Similarly, settings controlling bias adjustments to ensure mean unbiased recruitment from the lognormally distributed estimates were tuned according to recommended inputs after initial runs of the models (Methot and Taylor 2011).

Models included fishing fleets with retained catch and discarded catch, as well as surveys providing indices of abundance. Fishing fleets are defined based on sectors and fishing gears with different regulations and selectivity patterns. Each survey includes a catchability coefficient scaling its relative catch rate to the absolute abundance it is tracking. Fishery catch occurs throughout the year, while monitoring surveys sample at specified points within the year.

Selectivity of fishing fleets is modeled as length-based double normal selectivity patterns with retention curves and discard mortality specifications. The double normal selectivity pattern is a six parameter function with one parameter initializing selectivity at the starting length/age, a parameter defining the rate of ascending selectivity, a parameter defining where full selectivity peaks, a parameter defining the width of the full selectivity dome (if dome-shaped, which it is for fisheries and inshore monitoring surveys), a parameter defining the rate of descending selectivity, and a parameter defining constant selectivity of the largest sizes/ages following the descent from full selectivity. These selectivity patterns represent selectivity for total catch. Catch is partitioned into retained catch and discards according to a five parameter length-based, dome-shaped retention curve. Two retention parameters define ascending selectivity (inflection and width), one parameter defines peak values of retention between 0 and 1 (asymptote), and two parameters define descending selectivity (dome inflection, dome width). Retention is assumed to be dome-shaped due to slot limit regulations used through time. Subsequently, discards are partitioned into live discards and dead discards according to a specified discard mortality rate. Retention was allowed to change through time in a blocking pattern based on changes in regulations.

Selectivity of surveys was modeled as recruitment (special type=33) or age-0 age-based selectivity for young-of-year catches and length- or age-based double normal selectivity patterns for sub-adult catches. Length- or age-based logistic selectivity patterns were used for adult longline catches.

For fleets and surveys with estimated length-based selectivity, age-based selectivity patterns are derived from length-based selectivity and the internal growth model. Furthermore, parameters which were less informed by the data or contained excessively high variance were constrained using a symmetric beta prior to keep the parameter out of an unrealistic solution space (e.g., ascending retention inflection below 15 cm) or local minima.

Data sets fit in the models include fishing fleet catches (retained and discarded) with PSEs (recreational fleets) or assumed SEs (commercial fleets) as measures of variance, survey indices of abundance with CVs as measures of variance, and length and age compositions for the fishery catches and survey indices of abundance with effective sample sizes based on number of sampling trips observing red drum lengths or ages as measures of variance. Both marginal age compositions and conditional age-at-length data were utilized in the models. Marginal age compositions are those that describe distribution of catches/indices across ages within a year as determined according to age-length keys external to the assessment models. Conditional age-at-length data are frequencies of ages observed within length bins.

The model derived estimates included a full time series of SPR, recruitment, population abundance, and biomass (total, spawning stock, and exploitable).

#### Maximum Likelihood and Uncertainty

A maximum likelihood approach was used to evaluate the overall goodness of fit to each kind of data set. Data sets contained an assumed error distribution and an associated likelihood determined by the difference between observed and predicted values and the variance of the error distribution. The error structure for landings, discards, and indices was assumed to be log-normal. Multinomial distributions were assumed for the length and age composition data of the landings, discards, and indices, which have the variances estimated by the input effective sample sizes. The variance of the multinomial distribution is a function of true probability and sample size; thus, an increase in sample size represents lower variance and vice versa. No additional re-weighting methods on the length and age composition data (Francis 2011) were applied to base models, but rather are provided as sensitivity configurations. The total likelihood is the sum of the individual component's likelihoods. The global best fit to all the data was determined using a nonlinear iterative search algorithm to minimize the total negative log-likelihood across the multidimensional parameter space.

Several approaches were used to assess model convergence and largely follow those described in Carvalho et al. (2021). All estimated parameters were checked such that none were estimated on a bound, which may indicate potential issues with assumed model structure or data. Next, the maximum gradient component (a measure of the degree to which the model converged to a solution) was compared to the final convergence criteria of 0.0001. Ideally, the maximum gradient component will be less than the criterion, but this is not an absolute requirement. The Hessian matrix (i.e., the matrix of second derivatives of the log-likelihood concerning the parameters, from which the asymptotic standard error of the parameter estimates is derived) was confirmed to be positive definite. Following these criteria, a jitter

analysis was conducted by adjusting parameter starting values according to a jitter factor (0.1), rerunning the model, comparing the total likelihood to that of the base model, and repeating the previous steps 200 times. The jitter analysis is done to determine if the base model has converged on a local minimum solution in the likelihood surface (i.e., finds a larger negative log likelihood than any of the jitter runs) and to determine sensitivity to starting value choices.

As a diagnostic of data conflicts between the various data components that can lead to model instability, a likelihood profile was conducted for the primary population scaling parameter in the model (R0). The profile is done by fixing the parameter value, rerunning the model, examining likelihoods and repeating these steps over a range of plausible values for the parameter. A profile plot comparing change in likelihoods across the range of parameter values will ideally show a well-defined u-shape in the likelihoods with a minimum around the parameter value estimated in the base model.

Uncertainty estimates for estimated and derived quantities were calculated with the delta method after the model fitting based on the asymptotic standard errors from the covariance matrix determined by inverting the Hessian matrix (Methot and Wetzel 2013). Asymptotic standard errors provided a minimum estimate of uncertainty in parameter values.

Uncertainty is further assessed through a sensitivity analysis and retrospective analyses. Sensitivity analysis compares model estimates with key configuration or data input changes to the base model to determine sensitivity of the model to these configuration choices and data inputs. Retrospective analysis is done by sequentially dropping the final year of data from the model (a retrospective “peel”) and rerunning the model. Ideally there will be no pattern in the difference of estimates for overlapping years across retrospective peels that indicates a retrospective bias. A historical retrospective analysis was also done by comparing estimates from this current assessment with those of the previous benchmark stock assessment (ASMFC 2017) to evaluate similarities and differences between stock assessments.

While these diagnostics for model uncertainty were fully explored for the southern stock SS model, model instability precluded the use of many of these explorations for the northern stock SS model.

### Reference Point Calculations

Reference points for the models include  $F_{30\%}$ ,  $SPR_{30\%}$ , and  $SSB_{30\%}$  as thresholds and  $F_{40\%}$ ,  $SPR_{40\%}$ , and  $SSB_{40\%}$  as targets (Table 52 and Table 53). The  $F_{xx\%}$  benchmarks are in terms of age-2 fish and are the levels of fishing mortality that achieves the SPR of the same percentage. These reference points are calculated with terminal three-year averages of life history characteristics, selectivity, and fleet-specific relative fishing mortality. The  $SSB_{xx\%}$  benchmarks are the levels of SSB associated with a stock fished at the SPR of the same percentage. The SPR/F reference points are established reference points in the FMP (ASMFC 2002), while the  $SSB_{xx\%}$  reference points are new reference points in this assessment and were supported by the simulation assessment (ASMFC 2022).



## Stock-Specific Configuration Details and Data Inputs

### Northern Stock

The northern stock has three fishing fleets (Table 54) and three monitoring surveys (Table 55). Fishing fleets include a commercial fleet fishing gillnets and beach seines (North\_Commercial\_GNBS), a commercial fleet fishing other gears (mostly pound nets, North\_Commercial\_Other), and a recreational fleet (North\_Recreational) fishing hook and line gears. The monitoring surveys include a survey indexing age-0 recruitment (NC\_BagSeine), a survey indexing primarily sub-adult abundance inshore (NC\_GillNet), and a survey indexing mature abundance (NC\_Longline).

The North\_Commercial\_GNBS and North\_Recreational fleets include retained catch, discarded catch, length compositions for retained and discarded catch, and conditional age-at-length data for retained catch. Discard mortality for the North\_Commercial\_GNBS fleet was set to 1 as all discards used in the model were calculated externally as dead discards (observed dead discards plus 5% of observed discards released alive and assumed to die post release; Section 4.1.2.2). The North\_Recreational fleet discard mortality was fixed at 0.08 for all sizes, consistent with past assessments. As there are no discard estimates for either the number of fish discarded or the lengths for the North\_Commercial\_Other fleet, this fleet was modeled as a harvest-only fleet. The North\_Commercial\_Other fleet includes retained catch, length compositions, and conditional age-at-length data for retained catch. Retention parameters for the model were allowed to change based on a parsimonious approach of allowing only individual parameters expected to change given a regulation change to vary (e.g., retention inflection and width parameters following a minimum size increase). Time-varying retention parameters for the North\_Commercial\_GNBS and North\_Recreational fleets were based on changes in regulations over time, mainly in North Carolina. They were evaluated by examining changes to composition data fits during model development to structure the final retention blocks. Selectivity blocks were not used for the North\_Commercial\_Other fleet due to model instability and strange selectivity patterns where smaller fish were selected in the earliest period when there were very few regulations. The final retention and selectivity blocks are shown in Table 56.

The growth parameter for Amin in the northern model was fixed at 6 cm to anchor the growth curve as developmental model runs had the Amin parameter estimated as unrealistically high values. The age at Amin was also lowered to align with fish at this size. Symmetric beta priors were also used on the length at Amax ( $L_{inf}$ ) and  $\ln(R0)$  to keep the estimates of these parameters within a reasonable parameter space.

The initial model run presented in this report for the northern stock estimated the selectivity parameters for all three fishing fleets (hereafter referred to as the estimated selectivity model). This resulted in a narrow selectivity for the recreational fleet and low selectivity for larger sized fish that did not match an external source of selectivity information (Bacheler et al. 2010) or expectations formed by expert opinion. This model was unstable and it was difficult to get it to converge. Models often had very large maximum gradients and the Hessian was not positive definite.

An alternative model run was conducted to improve model stability by fixing the selectivity parameters for the fishing fleets based on values used from the simulation assessment (ASMFC 2022). Initial runs of this model with the selectivity fixed for all three fleets showed reasonable model fits to the length composition data for the North\_Commercial\_GNBS and North\_Recreational fleets; however, the length composition estimated for the North\_Commercial\_Other fleet did not align with the observed data, suggesting a possible misspecification from the simulation assessment. Because of this, the final alternative model fixed the selectivity parameters for the North\_Commercial\_GNBS and North\_Recreational fleets and estimated the selectivity parameters for the North\_Commercial\_Other fleet. Retention parameters were still estimated for the North\_Commercial\_GNBS and North\_Recreational fleets in these models.

The method used to estimate fishing mortality in the models was the hybrid approach (SS F method 3). This method uses a Pope's approximation to estimate the initial values of F and then iteratively adjusts the Baranov continuous F values to closely match the observed catch. F method 4, which is a new fleet-specific parameter hybrid approach with fleet-specific annual fishing mortality estimated as parameters, was also explored during model development due to recommendations of estimating fishing mortality parameters when there is uncertainty around annual input catch values and in situations when fishing mortality is expected to be high (Methot et al. 2023). Model fits, however, did not change and many of the annual F estimates were estimated at the lower and upper bounds, and there was a desire to keep the model simple and minimize the number of parameters being estimated due to model stability. For these reasons, the two models presented here used F method 3 rather than 4. Symmetric beta priors were used on the initial F estimates for the three fishing fleets to keep the estimates away from the lower bound of 0.

Monitoring surveys included indices of abundance, length compositions for the inshore, sub-adult survey, and conditional age-at-length data for both the inshore, sub-adult survey and offshore, adult longline survey. Length compositions were not included for the offshore, adult longline survey due to early model runs which suggested there may have been data conflicts between the length and conditional age-at-length composition data.

Data time series are shown in Figure 125.

### Southern Stock

The southern stock has three fishing fleets (Table 57) and seven monitoring surveys (Table 58). Fishing fleets include recreational fleets fishing hook and line gears for each of the three states in the southern stock. Historically, commercial red drum fishing did occur in these states, but most of this fishing was eliminated by the late 1980s. The only non-negligible commercial catch came from Florida in the early 1980s (Section 4.1.1.1; Table 23). Commercial selectivity was assumed to have been similar to recreational selectivity and, therefore, any commercial catch was interpreted as part of the recreational fleet when it did occur in the earlier years (i.e., combined with the recreational catch). The monitoring surveys include three surveys indexing

age-0 recruitment, three surveys indexing primarily sub-adult abundance inshore, and one survey indexing mature abundance.

Fishing fleets include retained catch, discarded catch, length compositions for retained and discarded (except SC) catch, and conditional age-at-length data for retained catch. Discard mortality for these recreational fleets was fixed at 0.08 for all sizes, consistent with past assessments. Retention parameters were allowed to change based on a parsimonious approach of allowing only individual parameters expected to change given a regulation change to vary (e.g., retention inflection and width parameters following a minimum size increase). Time-varying retention parameters were evaluating by comparing model likelihoods and examining changes to composition data fits during model development to structure the final retention blocks. The final blocks are shown in Table 59.

The fishing fleet selectivity parameters defining the width of the full selectivity dome were poorly or not informed by available data, were not well estimated, and resulted in narrow domes that did not match external sources of selectivity information (Bacheler et al. 2010; Troha 2023) or expectations formed by expert opinion. Further, the parameters defining the size at which full selectivity first peaks were well estimated, anchoring the beginning of the full selectivity dome. Therefore, the width parameters were fixed so that descending selectivity would start at  $\approx 75$ cm given peak parameters estimating full selectivity starting at  $\approx 40$  cm. This fixed value was based on the mid-point of the largest size bin (70-79 cm) estimated by Troha (2023) to have full selectivity in the SC\_Trammel survey. This survey uses a gear that selects all sizes encountered by the recreational fishery and operates at similar times and in similar areas as the recreational fishery.

Due to the lack of length composition data for the SC\_Recreational fleet to inform selectivity of the largest sized red drum encountered by the trophy adult catch and release fishery, an informative normal prior was also included in the model for the parameter defining selectivity of these sized fish. The prior mean and standard deviation were set based on the Troha (2023) estimate for recreational release selectivity of the largest regularly encountered size bin in the data set used in this study (90-99 cm). There are intermittent catches of larger sizes, but these fish were not encountered consistently through periods evaluated in the study.

The method used to estimate fishing mortality in the model was the new fleet-specific parameter hybrid approach (SS F method 4), with fleet-specific annual fishing mortality estimated as parameters. This method was explored during model development due to recommendations of estimating fishing mortality parameters when there is uncertainty around annual input catch values and in situations when fishing mortality is expected to be high (Methot et al. 2023). Model fits, particularly to discard data, improved with this method and it was adopted in the base model.

Monitoring surveys included indices of abundance, length compositions, marginal age compositions (inshore, sub-adult surveys), and conditional age-at-length data (offshore, adult longline survey).

During model development, data conflicts contributing to model instability were identified between longline survey data sets capturing information on the mature, adult population and data sources including information primarily on the sub-adult components of the stock (inshore surveys, fishing fleet catches). Longline survey index trends conflicted with other data sets, including (1) the SC\_Longline\_historic survey index showing a relatively flat trend and little change in population biomass despite sub-adult data sets indicating large changes in biomass during earlier years and (2) the GA\_Longline survey index showing a generally increasing trend which conflicted with the SC\_Longline\_contemporary survey index of the same time period and sub-adult data sets indicating declining trends in biomass during earlier years. Given these conflicts, only the contemporary SC\_Longline\_contemporary survey was retained in the model.

Additionally, the SC\_Longline\_contemporary survey composition data showed decreasing mean size and age trends that the model did not expect given decreasing biomass driven by reduced recruitment to the adult population. To address this conflict, the model estimated selectivity patterns that pushed selectivity to the largest sizes/ages without ever reaching full selectivity. Therefore, the length composition data for this survey was excluded from the model and the length-based selectivity was fixed based on estimates from Troha (2023). The conditional age-at-length data were retained, but with a non-defined age selectivity pattern so these data could inform growth of the larger sized fish and early recruitment deviations used to define the initial population structure.

Data from an additional inshore monitoring survey, the SC\_Electro survey, not included in the models during the simulation assessment was included in some early model development. However, inclusion of the survey data resulted in deteriorating model stability with several model parameters moving to bounds and nonsensical population estimates (biomass and SPR estimates at zero in all years), so the survey was not included in the final model.

Data time series are shown in Figure 126. Note that some of these surveys have been discontinued.

## 6.2.2 Results

### Northern Stock

The estimated selectivity model had a maximum gradient component of 0.00425 with a Hessian matrix that was positive definite. There were 62 estimated parameters and 54 estimated deviations (Table 60 - Table 62). Thirteen parameters were estimated at or within 1% of their bounds, no parameter pairs were highly correlated ( $> \pm 0.95$ ), and nine parameters had low correlations ( $< 0.01$ ) with all other parameters.

Attempts to adjust bounds on the estimated selectivity model often resulted in the model not converging (e.g., resulted in large gradients and a Hessian that was not positive definite). In order to see if a better set of starting values could be found, a jitter analysis of fifty runs was conducted using a jitter factor of 0.25. Nineteen runs in the jitter analysis estimated a solution with a negative log-likelihood identical to the base estimated selectivity model and six runs estimated a solution with a slightly smaller negative log-likelihood (Table 63). The remaining

twenty-five runs had larger negative log-likelihoods and did not converge. The results of the runs with the smaller negative loglikelihood were very similar to those from the initial estimated selectivity model. The main difference was the estimated retention curve for the first retention block of the North\_Commercial\_GNBS fleet. The retention curve from the lower log-likelihood model was much narrower in the first regulatory block than the initial model. This result was counterintuitive given the fewer size regulations in place at that time. Given the wider North\_Commercial\_GNBS fleet retention curve and that most of the converged model runs converged on the initial estimated selectivity model solution, the results from this model are presented.

Fits to the catch data were very tight as expected with F method 3 (Figure 127-Figure 129). The model fits to the North\_Commercial\_GNBS and North\_Recreational discards showed patterning, especially after 1990 (Figure 130 and Figure 131). While the estimated discards fit well for the North\_Commercial\_GNBS fleet in the 1980s, the model tended to overestimate the number of discards for this commercial fleet starting in the 1990s and diverged more by the late 1990s and early 2000s. In contrast, the number of recreational discards tended to be slightly overestimated in the 1980s by the model and were underestimated starting in the late 1990s and early 2000s.

Fits to survey indices of abundance varied depending on the index (Figure 132 - Figure 134). The model generally fit the NC\_BagSeine survey well in the later part of the time series though the model tended to overestimate the large 2011-year class. However, the model tended to underestimate the index early in the time series, resulting in some residual patterning and not fitting well to the peaks in abundance observed in the early 1990s. The fit to the NC\_GillNet survey was generally good and the residuals did not show any concerning patterning. The model had trouble fitting the greater observed interannual variability for the NC\_Longline survey due to the survey covering such a large number of year classes. Because of this, the model estimates a decreasing trend through the index.

The model generally fits length compositions well across the time series (Figure 135), with some slight difficulties estimating the bimodal patterns observed in the length frequencies for most of the fleets between 30-75 cm. This lack of fit is seen for annual data sets as well (Figure 136 - Figure 140).

Fits to the conditional age-at-length were generally good though the model tended to underestimate the mean ages early in the time series for all three of the harvest fleets. While the model slightly underestimated the mean age of fish from the North\_Commercial\_GNBS fleet early in the time series, it generally fit well starting in 1995 (Figure 141). A similar pattern was observed in the mean age data for the North\_Commercial\_Other fleet (Figure 142) and the North\_Recreational fleet (Figure 143) where the mean age is underestimated early in the timeseries and begins to match better starting around 2000. Fit to the conditional age-at-length data for the NC\_GillNet survey showed a bias with the model tending to overestimate the mean age through time (Figure 144). Fits to conditional age-at-length data for the NC\_Longline survey

tended to be better other than a period from 2014-2019 where the mean age tended to be overestimated by the model (Figure 145).

Length-based selectivity estimates for the commercial and recreational fishing fleets all had dome-shaped selectivity patterns that ascend and descend sharply but the widths varied (Figure 146). The widest selectivity was estimated for the North\_Commercial\_GNBS fleet. The North\_Commercial\_Other fleet had a narrow selectivity that was shifted to the right of the other curves due to the lack of discard information available for this fleet. The North\_Recreational fleet selectivity was also narrow and did not select for any larger fish, contrary to expert knowledge of the fishery. The North\_Recreational selectivity was similar to that estimated for the NC\_GillNet survey. The age-based selectivity pattern of the NC\_Longline survey shows recruitment to the mature, adult stock around age 5 with an estimated age of inflection at age 19.5 (Figure 147). Derived age-based selectivities for the harvest fleets and the gill net survey show selectivity focused on ages 1-3 with very sharp selectivity peaks. Retention estimates generally show narrowing domes through time as regulations become more restrictive for the North\_Commercial\_GNBS and North\_Recreational fleets (Figure 148 and Figure 149). While a model was attempted that included selectivity blocks for the North\_Commercial\_Other fleet, the resulting estimates for the second selectivity block just shifted the entire curve to the right suggesting harvest of even larger fish as regulations began to tighten in the early 1990s. Given this model behavior, as well as continued issues with model stability, this fleet was simplified and the blocks were not added.

Recruitment deviations show random variation around time series average recruitment levels during the modeled years (i.e., Beverton-Holt stock-recruit relationship with steepness fixed to 0.99; Figure 150). This resulted in generally flat levels of recruitment other than the large 2011-year class (Table 64, Figure 151). However, the model estimated very large, positive deviations in the 1970s. While the age data from the longline survey supports these large year classes in 1973 and 1978, the deviations were concerning as they were above the large year-class in 2011 which seemed unlikely.

These large year classes in the 1970s that the model estimated were not available to the fishery (based on the estimated selectivity curves) and resulted in the model estimating an overall downward sloping population trend that appeared to show just the effects of natural mortality through time (Table 64, Figure 152). In the estimated selectivity model, the overall population numbers decreased through time and began to flatten out around the late 2000s. It is after this point that the population begins to show peaks due to larger year classes entering the population. SSB shows this same trend (Table 65, Figure 153).

The model, even using symmetric beta priors to keep the initial fishing mortality estimates away from the lower bound, consistently wanted low initial  $F$ s for all three fishing fleets. This results in a general trend of increasing fishing mortality on age-2 fish through time with the highest levels of  $F$  in recent years (Table 66, Figure 154). This trend in  $F$  resulted in the estimated selectivity model having very high SPRs early in the time series when it is thought the stock size was low and SPRs decreasing towards the threshold in recent years (Table 66, Figure

155). Despite the decreasing SPRs through time, the SPRs remained above the threshold except for the final year of the time series. The terminal three-year average SPR was estimated at 0.603 (Table 66).

The historical retrospective analysis for the northern stock shows divergent SPRs between the previous statistical catch-at-age model and the new SS model in the beginning of the time series and the scale of the SPR estimates from the two models converge around 2010 (Figure 156). While the scales are different early in the time series, both models show a generally increasing SPR in the early 1990s which begins to decrease in the mid- to late-2000s.

There were multiple concerns with the estimated selectivity model. While model stability was a large one, there were also concerns about the high recruitment deviations estimated in the 1970s which drove a lot of the population trends observed. Additionally, the recreational fleet selectivity pattern did not match expert opinion with the narrow estimated selectivity and lack of selectivity on larger fish when it is known that a fishery exists for large bull red drum. Lastly, the low initial  $F_s$  and trends in stock biomass did not align with expectations of the history of the fishery through time.

In an effort to improve model stability, a second model was run where the North\_Commercial\_GNBS and North\_Recreational selectivities were fixed based on parameters used in the simulation assessment (ASMFC 2022). The retentions for these fleets across the three regulatory periods were still estimated. The North\_Commercial\_Other fleet selectivity was also initially fixed based on parameters used in the simulation assessment but fits to the observed length composition data were poor indicating a possible misspecification in the simulation assessment. Because of this, the selectivity was estimated for the North\_Commercial\_Other fleet and as before, was estimated without selectivity blocks. This model, with selectivity fixed for two of the harvest fleets and estimated for one, is referred to as the hybrid selectivity model in this report.

The hybrid selectivity model had a maximum gradient component of 0.01789 with a Hessian matrix that was positive definite. There were 54 estimated parameters and 54 estimated deviations. No parameters were estimated at or within 1% of their bounds, no parameter pairs were highly correlated ( $> \pm 0.95$ ), and three parameters had low correlations ( $< 0.01$ ) with all other parameters. Compared to the estimated selectivity model, the  $\ln(R_0)$  parameter was estimated lower for the hybrid selectivity model (6.69 vs. 7.91) resulting in a lower stock size overall.

Fits to the catch data in the hybrid selectivity model were very similar to those estimated by the estimated selectivity model (Figure 127 - Figure 129). The model fits to the North\_Commercial\_GNBS and North\_Recreational discards again showed patterning as was seen in the estimated selectivity model (Figure 130 and Figure 131). While the North\_Commercial\_GNBS discards continued to be overestimated by the model, especially after the late 1990s, and the North\_Recreational discards continued to be underestimated in the same time period, the use of the fixed selectivities caused these patterns to become more pronounced.

Fits to survey indices of abundance again varied depending on the index (Figure 132 - Figure 134). The fit to the NC\_BagSeine survey under the hybrid selectivity model slightly underestimated the survey in the early part of the time series and overestimated the survey in the later part of the time series compared to the estimated selectivity model. Similarly, the fit to the NC\_GillNet survey index using the hybrid selectivity model resulted in the survey being underestimated in the early part of the time series and overestimated in the later part of the time series compared to the estimated selectivity model. It seemed that the hybrid selectivity model was less influenced by the 2004 and 2005 gill net index points than the estimated selectivity model. As before, the hybrid model also estimated a decreasing trend through the NC\_Longline index and did not fit the observed interannual variability well.

Despite the hybrid selectivity model having the selectivities fixed for the North\_Commercial\_GNBS and North\_Recreational fleets, the model generally fit the length compositions well across the time series (Figure 135). While the second peak for the North\_Commercial\_GNBS discards isn't fit as well using the hybrid selectivity model, and neither is the largest peak in the recreational discards, the fits in general to the length compositions did not change that much from the estimated selectivity model.

Fits to the conditional age-at-length also did not seem to change much with the hybrid selectivity model. The North\_Commercial\_GNBS fleet mean age was fit a little better early in the time series when compared to the estimated selectivity model (Figure 141); however, the fits to the conditional age-at-length data for the North\_Commercial\_Other and North\_Recreational data were very similar between the models (Figure 142 and Figure 143). Fits to conditional age-at-length data for the NC\_GillNet survey continued to not fit as well with the model again tending to overestimate the mean age through time (Figure 144). Fits to conditional age-at-length data for the NC\_Longline survey continued to fit well and the period from 2014-2019 no longer was consistently overestimated (Figure 145).

Length-based selectivity estimates for the commercial and recreational fishing fleets under the hybrid model again all had dome-shaped selectivity patterns that ascend and descend sharply and the North\_Commercial\_GNBS and North\_Recreational selectivities were fixed (Figure 146). The fixed selectivity of the North\_Commercial\_GNBS was very similar to that estimated in the estimated selectivity model. The North\_Recreational selectivity was fixed to be much wider than that estimated by the estimated selectivity model and had a selectivity of around 0.2 for larger fish. The North\_Commercial\_Other selectivity was estimated as a narrow selectivity curve, similar to that estimated in the estimated selectivity model. After fixing the selectivities of those two fleets, the NC\_GillNet selectivity estimated by the hybrid selectivity model was much wider than that estimated by the estimated selectivity model. The age-based selectivity pattern of the NC\_Longline survey was very similar between the two models though the estimated age of inflection was slightly larger (20.7) and the curve had a slightly narrower width estimated (Figure 147). Derived age-based selectivities for the harvest fleets and the gill net survey still select mostly ages 1-3 fish but the recreational age-based selectivity was slightly broader than that estimated by the estimated selectivity model. Retention estimates for the North\_Commercial\_GNBS fleet were estimated to be much broader using the hybrid selectivity



model though it still showed a narrowing of the retention curves through time as regulations tightened (Figure 148). The retention estimates for the North\_Recreational fleet showed a more gradual change in the retention curves across the regulatory blocks than was observed in the estimated selectivity model which seemed to shift up and down slightly between periods (Figure 149).

Recruitment deviations in the 1970s for the hybrid selectivity model were more in line with the large 2011 year-class and seemed more reasonable in scale (Figure 150). As before, the recruitment deviations between 1981 and 2021 were fairly flat and generally varied without trend around the mean. This resulted in generally flat levels of recruitment other than the large 2011 year-class (Figure 151). Additionally, the scale of the recruitment estimates were quite different between the estimated and hybrid selectivity models with the hybrid selectivity recruitment estimated to be much smaller.

With the reduced scale of the population, the total population numbers no longer showed a decreasing trend over time as seen with the estimated selectivity model (Figure 152). Overall population numbers decrease through the 1980s before increasing again slightly in the mid-1990s. The population numbers estimated by the hybrid selectivity model begin to bounce around more starting in 2010 through the end of the time series. SSB estimated by the hybrid selectivity model still showed a downward sloping trend through time, though again the scale was much lower than what was estimated by the estimated selectivity model (Figure 153).

The hybrid selectivity model, again using symmetric beta priors to keep the initial fishing mortality estimates away from the lower bound, still consistently wanted low initial  $F_s$  for all three fishing fleets. This again resulted in a general trend of increasing fishing mortality on age-2 fish through time with the highest levels in recent years (Figure 154). However, compared to the estimated selectivity model, the  $F_s$  were scaled much higher. This resulted in the hybrid selectivity model having estimated larger SPRs ( $\sim 0.6$ ) early in the time series and the stock being fished down to very low SPRs quickly (Figure 155). SPRs remained below the threshold for all years of the time series beginning in 1984. The terminal three-year average SPR was estimated at 0.068.

While there were differences in model fits between the hybrid and estimated selectivity models which resulted in very different model scales, the model trends in  $F$  and SPR were very similar when plotted standardized to their means (Figure 157). This suggests that the models are each picking up the same trend of an increasing  $F$  through time even if the scale of the overall population is uncertain.

### **Southern Stock**

The base model had a maximum gradient component of  $5.76014e-05$  with a Hessian matrix that was positive definite. There were 201 estimated parameters and 54 estimated deviations (Table 67 - Table 70). No parameters were estimated at their bounds, no parameter pairs were highly correlated ( $> \pm 0.95$ ), and no parameters had low correlations ( $< 0.01$ ) with all other parameters.

One hundred and ninety-two of the two hundred runs in a jitter analysis estimated a solution with a negative likelihood identical to the base model (Table 71). Three runs converged on solutions with larger negative loglikelihoods than the base model and five runs did not converge. These results provide no evidence that the model has converged on a local minimum in the likelihood surface and indicate the base model is fairly insensitive to starting parameter value choices.

Fits to catch data show some divergence, particularly for the FL\_Recreational fleet, during a few years in the early 1980s and again in the mid-2010s (Figure 158). The misfit in the 1980s was reduced with changes to the retention parameterizations, but the misfit in the mid-2010s could not be resolved. The model fits fishery discards well (Figure 159).

Fits to survey indices of abundance show no concerning residual patterns indicative of major model misspecification (Figure 160 - Figure 162). Fits to indices from inshore surveys in the early 1990s indicate some balancing of data conflicts with the SC\_Trammel survey index showing a strongly declining trend while the SC\_StopNet survey index shows a flatter period of abundance at the end of its short time series. The model has trouble fitting the greater observed interannual variability of a few years around 2010 for the SC\_Longline\_contemporary survey than is expected for a survey covering such a large range of year classes.

The model generally fits length compositions well across the time series (Figure 163), with some slight difficulties capturing sharp multimodal patterns of the fast-growing sub-adults and some of the limited, noisier data sets (i.e., recreational discards). This lack of fit is seen for annual data sets as well (Figure 164 - Figure 171).

Fits to age compositions capture the sharp domes of ages available to the inshore surveys (Figure 172). There is some residual patterning through time, particularly around the mid-2010s, for older ages captured by the SC\_Trammel survey, with the model expecting fewer of these older fish being captured by the survey, and through the 2000s for age-0 fish captured by the FL\_183\_HaulSeine survey, with the model expecting more age-0 fish than observed (Figure 173). Fits to conditional age-at-length data capture the trends in age structure for the recreational fleets, though there is some lack of fit to the earliest years of data from the SC\_Recreational fleet and a period of years from the late 2000s through the early 2010s from the GA\_Recreational fleet (Figure 174). It was unclear why the age structure of samples collected in Georgia shifted to older ages in these years before shifting down to a younger and more stable age composition in later years as there were no regulation changes that would explain this shift. Fits to conditional age-at-length data for the SC\_Longline\_contemporary survey show some patterning with poorer fits in early years and good fits in recent years (Figure 175). This appears to be a data conflict with the model expecting less of a decline in the age structure captured by this survey than observed given the declining recruitment to the adult population indicated by sub-adult data sets. Similar trends were observed in fits to the length data for this survey leading to its exclusion from the model, but the conditional age-at-length data were retained in the model despite the misfit to provide information on adult growth and early recruitment deviations prior to the start of the model time series.

Length-based selectivity estimates for the recreational fishing fleets show similar broad dome-shaped selectivity patterns that ascend and descend sharply as red drum grow rapidly to exploitable sizes and then emigrate from inshore habitats, respectively (Figure 176). The fixed selectivity pattern of the SC\_Longline\_contemporary survey shows recruitment to the mature, adult stock at sizes starting around the size recreational selectivity has descended to lower constant values representative of the adult catch and release fishery. The SC\_Recreational fleet has the highest selectivity of mature adults, followed by the GA\_Recreational fleet and then the FL\_Recreational fleet. Retention estimates show narrowing domes through time as regulations become more restrictive (Figure 177). Estimated selectivity patterns for inshore monitoring surveys show strongly dome-shaped patterns covering the first few age classes (Figure 178). The SC\_Trammel survey selects the broadest age range of the inshore surveys.

Recruitment deviations show random variation around time series average recruitment levels (i.e., Beverton-Holt stock-recruit relationship with steepness fixed to 0.99; Figure 179). However, positive deviations in the 2010s were generally smaller than those in earlier decades indicating reduced recruitment in recent years (Table 72, Figure 180). There was a large year class predicted in the 2022 fishing year (the largest of the time series) that had yet to recruit to the fisheries, as indicated by several of the indices of abundance. Additionally, there were several relatively large negative deviations around the model start year indicating a depleted exploitable population in the early 1980s.

Overall population numbers show increases through the 1980s and early 1990s, variable but higher levels through the late 1990s and 2000s, followed by a decline since 2010 (Table 72, Figure 181). Pulses of abundance increase are notable in the early 1990s, early 2000s, and late 2000s. SSB increases from low levels in the 1980s and peaks in the late 2000s then declines through the remainder of the time series (Table 73, Figure 182). Relative to the SSB produced from fishing the stock at 30% SPR, the SSB was well below this threshold at the start of the time series, first exceeded this threshold in 1993 and remained above this threshold through 2018, and has continued a declining trend below this threshold since 2019 (Table 73, Figure 183). The terminal three-year average (2019-2021) relative biomass is 0.881, indicating the stock is overfished (Table 73). The upper limit of the 95% confidence intervals based on asymptotic standard errors for annual relative spawning stock biomass estimates making up the terminal three-year average are at the threshold (1.0 in 2021) or slightly above the threshold (1.2 in 2019 and 1.1 in 2020).

Florida has accounted for the majority of catch from the stock and exhibited the highest fishing mortality levels of the three fishing fleets, followed by South Carolina and then Georgia (Table 69, Figure 184). All fleets have increasing fishing mortality since the 2000s that peaks at or above levels in the early 1980s near the terminal year of the assessment. There is variability in the terminal year, but levels for all fleets remain high. There was a brief period of high fishing mortality, primary in Florida, in the early 1980s before Florida implemented several years of highly restrictive regulations including a moratorium. Overall, fishing mortality on age-2 fish was at its highest levels in the early to mid-1980s, decreased sharply in the late 1980s, and has followed an increasing trend through the late 2010s with an increased rate since the early

2010s (Table 74, Figure 185). Fishing mortality declined slightly in the last few years of the assessment but remains at high levels. In terms of SPR, high fishing mortality led to SPRs below the management threshold of 30% in the early 1980s. SPR then increased above the threshold (and target of 40%) in the late 1980s, followed by a declining trend that falls below the threshold again in 2013 (Table 74, Figure 186). SPRs remain below the threshold for the remainder of the time series. The terminal three-year average SPR is 0.207, indicating overfishing is occurring (Table 74). The upper limit of the 95% confidence intervals based on asymptotic standard errors for annual SPR estimates making up the terminal three-year average are below the threshold in two years (0.25 in 2019 and 0.28 in 2021) and above the threshold in 2020 (0.35).

A likelihood profile for the  $R_0$  parameter across a range of 8 to 10.5 with increments of 0.1 shows length data, discard data, and recruitment deviations all support a similar likelihood surface as the total likelihood with minima near that of the total likelihood (Figure 187). Some conflict among data sets is apparent with age data supporting a smaller  $R_0$ , while index data support a slightly larger  $R_0$ . Catch data are informative of the lower bound of the  $R_0$  parameter, but less informative of the upper bound. The total likelihood is the balance of these information sources and shows a well-defined total likelihood surface with a minimum at the base model estimate of 8.67.

A retrospective analysis with a six-year peel shows some retrospective bias in the model. The model has a tendency to underestimate SSB (Figure 188) and overestimate fishing mortality (Figure 189). The three-year peel (terminal year of 2019) diverges from the pattern of other peels and leads to a more severe retrospective bias. This divergence is due to the model having more flexibility to fit to decreased index values observed across several indices in the terminal year of this peel (Figure 191). In other peels, data before and after this year preclude the model fitting as closely to these index data points. With all peels, the Mohn's rhos, a measure of the retrospective bias, are just outside the rule of thumb range proposed by Hurtado-Ferro et al. (2015) for determining no retrospective pattern in an assessment of a long-lived species (-0.15-0.20; Figure 188 and Figure 189). With the three-year peel excluded from calculations, Mohn's rhos are within this range.

The SAS decided not to make retrospective bias adjustments to base model estimates for three reasons. First, the retrospective pattern is the less concerning directionality from a precautionary perspective (underestimating SSB, overestimating F). Second, the magnitude of Mohn's rhos are driven to larger values by the single divergent three-year peel. Finally, the adjustments using the Mohn's rho values would not change the stock status point estimates in the assessment terminal year.

The historical retrospective analysis shows very similar SPR estimates in the first four years that overlap between assessments (1989-1992; Figure 190). The SS model in the current assessment then estimates more of a decline for the remainder of the overlapping time series than the statistical catch-at-age model used in the previous assessment. Both assessments estimated a decline in the terminal year of the previous assessment (2013), but the SS model estimates a

greater magnitude in this decline. The wide confidence intervals from the last assessment generally include the point estimates and their confidence intervals from the current assessment and demonstrate one of the primary deficiencies of the previous assessment.

Nine sensitivity configurations are presented here (run names bolded and italicized) to demonstrate the impact of key model assumptions and data choices. A configuration with composition data set variances re-weighted according to the Francis (2011) iterative reweighting methods (*Reweight*) was compared to determine sensitivity to data weighting choices. A configuration with the start year advanced to 1989 (*1989*) was compared as this was the start year used in models in previous benchmark assessments and the simulation assessment due to reduced data quantity in earlier years. One advantage of SS is its ability to handle years with varying quantities of data and the early 1980s data available (catch) show contrast during years before most management went into place, so 1981 was adopted as the start year for the base model. A configuration with a reduced discard mortality rate assumption (4%, *4% discard*) was compared due to uncertainty around this value stemming from earlier assessments. The sensitivity value represents a 50% reduction to the base value (8%) and was the value suggested by reviewers of the simulation assessment. Two alternative data sets were used in sensitivity configurations dealing with uncertainty in MRIP catch estimates. The first included imputed wave 1 catch estimates for states that do not have consistent estimates for this wave (Georgia and South Carolina, see Section 4.2.1; *Wave 1*). The second included MRIP catch data sets (retained and discarded catch) reduced by 30% (*70% catch*) as a proxy for potential effects from pending re-estimation of effort data (see Section 4.2.1). The proxy data sets assume a linear relationship between catch and effort using the preliminary central tendency for effort reductions expected by MRIP staff (John Foster, NOAA, personal communication). Two alternative natural mortality values were evaluated as a standard source of uncertainty in stock assessment. The first configuration included the base model age-2 value decreased by 20% (*M -20%*) and the second configuration included the base model value increased by 20% (*M +20%*). As with the base model, natural mortality values for other ages are then calculated internally in SS with the Lorenzen (2005) method and model-estimated growth. The final set of sensitivity configurations were included to evaluate uncertainty from the fixed selectivity parameters used in recreational fleets. The parameters were changed in the first configuration so that descending selectivity would start at  $\approx 65$ cm given peak selectivity parameter estimates at  $\approx 40$  cm (*Descend 65*). The second configuration included fixed values with descending selectivity starting at 85cm given peak selectivity parameter estimates at  $\approx 40$  cm (*Descend 85*). These two alternatives represent mid-points of the two bins adjacent to that estimated to have full selectivity for the SC\_Trammel survey by Troha (2023) and covers the range the SAS believes is most likely to be where descending selectivity of the recreational fisheries starts. An additional configuration with steepness estimated was explored based on the recommendation in the simulation assessment, but the model estimated steepness at the upper bound of 0.99 which is the fixed value used in the base model. This indicates there is not enough information in the data to estimate steepness and returns identical results to the base model.

All sensitivity configurations estimate trends similar to the base model but show some uncertainty in scale. The most notable difference in scale comes from the *Descend 85* configuration. The stock is estimated to have experienced higher fishing mortality through time with the broader full selectivity dome (Figure 192), leading to lower SPRs that don't allow the stock to rebuild as estimated in the base model (Figure 193). The other notable divergence is the *1989* configuration. This model estimates a less depleted stock in 1989 than the base model (and all other sensitivity configurations) that declines at about the same rate as the base model since the late 2000s, but ends up just above the SSB threshold in the terminal year. This is the only configuration with a different terminal year SSB status than the base model. As with the base model, SPRs in the *1989* configuration fall below the threshold in 2013 and remain below the threshold consistently with the exception of 2020. The terminal three-year average SPR is below the threshold, consistent with all other runs. These results show there was additional information content in the pre-1989 data unavailable to the *1989* configuration that indicated a more depleted stock in 1989 (and all other years).

The model was consistently insensitive to data weighting throughout model development as is the case in this sensitivity analysis, therefore empirical weighting was used in the base model. The *70% catch* configuration primarily had a scaling effect on population biomass and abundance (Figure 193), but little effect on the relative SSB and F/SPRs. This is a good indication of effects if MRIP effort re-estimation leads to a consistent scaling effect to catch through time, but should be revisited if the effect is time-varying. Aside from the *1989* and *Descend 85* configurations, the model estimates of when the stock SSB was rebuilt is sensitive to configuration choices, ranging from 1990 in the *M +20%* configuration to 1997 in the *M -20%* configuration. However, the model is largely insensitive to configuration choices for terminal year SSB status with all these configurations converging to very similar levels.

## 6.3 Traffic Light Analysis

### 6.3.1 Background

The TLA was first developed (Caddy 1998; Caddy 1999; Caddy et al. 2005; Caddy and Mahon 1995) for application in data-limited fisheries and can provide an information basis for fish stock management decisions that is not constrained by a model-based framework.

The TLA uses colors like that of a traffic light to represent the state of a fishery based on appropriate indicators (i.e., an index or time-series of relevant data). Indicators are used to compare recent years of data with previous years to detect trends. The type of indicators may vary and can be based on population and/or fishery dynamics such as abundance, growth, reproduction, removals, or other metrics that are appropriate to the available data. These indicators may be derived from various fishery-independent or fishery-dependent sources (e.g., survey derived indices, harvest/landings time series) and can be representative of various phases in the life cycle (e.g., juvenile, sub-adult, adult). The temporal extent of appropriate indicators should span multiple generations to be representative of population trends.

One common method called the strict traffic light method uses hard boundaries based on reference points to assign a color and uses a binary logic model. Another method called the fuzzy traffic light method uses a fuzzy logic model where the transitional color (yellow) is based on the proportion of adjacent color the indicator is trending towards (e.g., yellow/red or yellow/green; Figure 194).

Reference points are identified as either threshold reference points or target reference points. A threshold reference point (the focus of this assessment, referred to hereafter as “threshold”) might be thought of as unacceptable outcomes such as an indicator value moving from yellow to red whereas target reference points are desirable outcomes where a stock status objective has been achieved such as a target SPR or SSB. Setting reference points requires identifying appropriate metrics to indicate when stock status moves from fully acceptable to unacceptable with a buffer zone between the two to provide warning of proximity to unacceptable conditions.

The TLA framework used in the assessment was previously developed for the simulation assessment (ASMFC 2022). Results of the simulation assessment suggested the TLA was useful as a potential assessment methodology for red drum, although there was some variability in the effectiveness based on stocks. The TLA was also observed to outperform the age-structured models in characterizing recruitment condition. Overall, the TLA showed utility as a supplementary assessment approach for development of fishing mortality status, SSB status, and recruitment condition determinations. The TLA can be updated relatively easily, potentially allowing for interim analysis between formal assessments to update stock status for management advice.

The objective here was to use the TLA framework to evaluate the status of the red drum populations in the northern and southern stocks.

### **6.3.2 Framework and Optimization**

A custom TLA framework was developed using R (code available upon request). The fuzzy method was applied to each indicator by calculating the relative proportions of each color for each year based on the trends from a selected reference period in the time-series that was considered representative of previous trends. This was accomplished by setting the expected value of an indicator to a relative proportion of 1 for yellow and 0 for red and green (Figure 194). The intersection of the color lines at 0.5 relative proportion corresponds to the 95% confidence intervals derived from the reference period values. The relative proportion of 1 for red and green and 0 for yellow were set to 2 times the confidence intervals. Corresponding linear regression equations were calculated to determine the slope and intercept coefficients which were used to determine a proportion of red, yellow, and green for each value of an index.

The resulting color proportions were then compared to a selected threshold and any value with a proportion red above the threshold would potentially trigger a management action, which can be based on a conditional rule such as a selected number of consecutive years above the

threshold. It was important to select an appropriate number of consecutive years above the threshold for the initiation of management action as a short time frame may be too sensitive to annual variability (stochasticity) in indicator values and can be mistaken for changes in fishing pressure. Conversely, a time frame requirement of too many consecutive years above the threshold may result in slow responsiveness to significant changes in fishing pressure.

Potential characteristics for the TLA (ASMFC 2022) were evaluated during the simulation assessment, with six being chosen based on available data from the stocks. Based on the results of that effort and further evaluation of the data these characteristics were reduced to three key characteristics: recruitment, adult abundance, and fishery performance (Table 75). Multiple indicators of the same characteristic were combined into composite “characteristics” designed to collectively represent a characteristic of interest for management (e.g., abundance, production, recruitment, fishery performance). These indicators are additive and the resulting combined index was rescaled from 0 to 1 (ASMFC 2020; Halliday et al. 2001).

It may be inappropriate to select a long time series for the reference period since long-term averages can be affected by regime shifts in stock productivity and/or fishing pressure. Therefore, the reference period was selected for the northern red drum stock as 1996–2013 and for the southern stock as 1991–2013 when these stocks were not experiencing overfishing based on the previous stock assessment results and based on when index data time series begin in each stock. The expected value was calculated as the geometric mean of the indicator values during the reference period and the confidence intervals were based on the expected value and standard deviation from the indicator values during the reference period. Model sensitivity to the reference period was evaluated by varying the duration and initial and terminal years of the reference period timeframe using 3-year increments.

Abundance indicators were developed from fishery-independent survey relative indices of abundance indexing various components of the stock abundance (Table 76). Fishery performance was defined as the relative harvest fishing mortality which was calculated by dividing the harvest by an appropriate survey (same state or stock where the fleet is operating) derived index of slot-sized fish for each year. The northern stock had one fishery performance indicator for NC, while the southern stock had two fishery performance indicators, one for SC and one for FL (no index of slot-sized fish in GA).

As in the simulation assessment, a grid search was performed to optimize the threshold (in reference to proportion red), number of consecutive years to trigger management action, and appropriate lag (when appropriate for sub-adults). In the simulation assessment, the grid search used information from the entire time series of the simulation, including the projection years, allowing the TLA to leverage information not available to the other models and unavailable to a TLA based on *in situ* data. Based on comments from the assessment review panel, it was recommended that only historic data should be used for optimization in future efforts (Section 1.3.2), and thresholds in this assessment were optimized using this recommended approach.



The grid search was performed for each year in the historic time-series and each characteristic over 100 simulated datasets for each of the core population dynamics scenarios (ASMFC 2022) and for both the northern and southern red drum stocks. The grid matrix consisted of potential threshold values ranging from 0.05 to 0.95 by 0.05 increments, and number of consecutive years to trigger management action from 1 to 10 years. The final optimized values for threshold and number of consecutive years to trigger management action were then applied to the observed data for each stock, scenario, corresponding characteristic, iteration, and for each year to calculate the proportion red and whether a management action was triggered.

The results for each individual characteristic were presented in chart form, displaying the annual color proportion relative to the threshold values. This allowed for the observation of annual variation and trends in characteristic conditions. Annual action determinations, based on thresholds and the number of years needed for a trigger, were produced in table form.

Stock status determinations are made from the TLA results (output table) according to the following scenarios:

- If fishery performance is red in any of the past three years, overfishing is occurring.
- If adult abundance is red in any of the past three years, the stock is overfished.

The SAS decided to include any of the past three years in stock status determinations to counter the risk of waiting too long to indicate poor stock status. Anywhere from six to ten consecutive years of proportion red exceeding thresholds are required for these metrics before indicating poor stock status in table form.

Additionally, the following scenarios represent concerning trends in the stock that the SAS recommends trigger action:

- If fishery performance is yellow in any of the past three years and recruitment is red for five consecutive years (a generation of the vulnerable population), there has been consistent below average recruitment and increasing catch and/or decreasing sub-adult abundance.
- If both fishery performance and adult abundance in any of the past three years are yellow, the stock is experiencing increasing catch and/or decreasing sub-adult abundance which is leading to declines in adult abundance.
- If recruitment is red for five consecutive years and adult abundance is yellow in any of the past three years, there has been consistent below average recruitment representing concern for the future of the adult abundance.

### **6.3.3 Results**

The threshold values estimated by the TLA were somewhat different from those in the simulation assessment, but similar for the northern (Table 77) and southern stocks (Table 78)

and. In general, the thresholds optimized using the historic only data were higher and had a greater number of years to trigger an action. This would seem to make sense based on there being less data in the shorter timeframe, leading to greater uncertainty in status determination for the model.

One decision that was made relative to the adult abundance characteristic was to halve (0.39) the optimized threshold value (0.78) to provide a more conservative determination for that value. This was based on the maturation and maximum age of red drum, where the adult population consists of many older age-classes. A decline in this older age-structure would have significant effects on the recruitment and stability of the population as a whole and using the higher threshold may not give managers adequate time to respond with corrective actions.

The final TLA status determinations for the 2021 fishing year varied by stock and characteristic (Table 80 and Table 79). The northern stock was determined to be yellow, triggering moderate management action, in the recruitment and fishery performance categories, while being green, triggering no action, for the adult abundance characteristic. Annual trends were less apparent, although there was a noticeable decline in fishery condition (Figure 195). The southern stock was red, indicating overfishing and triggering elevated management action, in the recruitment and fishery performance categories, while being yellow, triggering moderate action, for the adult abundance characteristic. The annual indicators suggest a possible declining trend for all three southern stock condition characteristics (Figure 196).

The TLA model results were insensitive to the selection of the reference period. For either stock the results of individual runs were either the same as the base period or only one category was different (Table 81 and Table 82). Of the 8 alternative reference periods for the northern stock, 6 had the same result as the base and 2 showed a decline to elevated action in the fishery performance category. Of the 11 alternative reference periods for the southern stock, 4 had the same result as the base and 7 showed an improvement to no action for the adult abundance category. The results were robust, but may be less so in cases where trends are stronger and individual years had results closer to thresholds. It was also observed that years within the reference period that noticeably deviated from the mean or outliers could have a strong effect on status determination.

## **6.4 Skate Data Limited Control Rule Method**

### **6.4.1 Background**

The Skate control rule method is a data-limited analysis developed to produce fishing mortality information using time series of observed catch and a survey index when fishing mortality cannot be calculated using stock assessment modeling or when estimates are uncertain (*i.e.*, questions about scaling; NEFSC 2020). The method uses a ratio of catch:index, using moving averages of each, to visualize how these two data streams co-vary through time:

$$Catch/Index_y = \frac{\frac{\sum_{y-a}^y Catch}{a+1}}{\frac{\sum_{y-a}^y Index}{a+1}}$$

where  $y$  is year  $y$  and  $a$  is an integer controlling the span of a moving average (e.g., if  $a = 2$ , three year-moving average). Increases in the ratio indicate increasing catch (i.e., increase in the numerator) and stable to declining relative abundance (i.e., denominator same or decreasing), stable catch (i.e., numerator constant) and decreasing relative abundance (i.e., denominator increasing), or decreases in both, with a larger decrease in relative abundance compared to catch (i.e., both numerator and denominator decreasing but decrease in denominator > numerator). Any of these scenarios can be indicative of unsustainable fishing pressure (e.g., overfishing).

The method defines a critical value of “relative  $F$ ” as the median ratio over the entire time series:

$$\text{Relative } F = \text{median}\left(Catch/Index\right)$$

Subsequently, recommended annual catch ( $C_{rec,y}$ ) is calculated as

$$C_{rec,y} = Catch/Index_y * \text{Relative } F,$$

and proportional change in catch in year  $y$  relative to catch in year  $y - 1$  is

$$Catch \Delta = \frac{C_{rec,y} - \frac{\sum_{y-a-1}^{y-1} Catch}{a+1}}{\frac{\sum_{y-a-1}^{y-1} Catch}{a+1}}$$

To aid in comparisons in catch advice across multiple catch and index time series (e.g., from different spatial areas), one can calculate a normalized catch:index ratio in year  $y$  as

$$Catch/Index_{norm,y} = \frac{Catch/Index_y}{\text{Relative } F}$$

for individual catch and index data streams. Once normalized, any ratio exceeding a value of one suggests unsustainable catch in year  $y$  given observed catch and index values and the range of values over the time series. The method proves useful in providing catch advice for the following year, particularly when the stock is determined to be experiencing overfishing and a reduction in catch is needed.

The Skate method, of several data limited approaches evaluated by the SAS (e.g., *ITarget* and other methods) capable of providing catch advice, was chosen as the preferred method. This was because the Skate method provides a current measure of exploitation on the most vulnerable portion of the stock that can be compared to reference levels and evaluated for

relative changes over time. The other methods considered used the recent impact of catch on the index of abundance to determine catch advice which is not appropriate for a recruitment-based fishery using an index of abundance that does not capture the cumulative effect of catch over time on the population due to rapid emigration offshore.

Herein, given the nature of the red drum fishery, the SAS decided to examine the relative  $F$  for the sub-adult population (i.e., segment of the population susceptible to harvest fisheries). For the southern stock, we used two sub-adult surveys to represent the index: the SC\_Trammel survey (only ages two and three; Table 84) and the FL\_183\_HaulSeine survey (Table 85). These indices were compared to each state's respective recreational harvest (Table 84 and Table 85) as estimated using the MRIP survey to develop annual catch:index ratios and subsequent relative  $F$ s. For the northern population a single sub-adult index was available for consideration, namely the NC\_GillNet survey. Hence, this index was compared to the entire northern stock's commercial and recreational catch (Table 83). For both stocks, 3-yr moving averages (i.e.,  $a = 2$ ) of catch and index time series were used in the calculation of catch:index ratios and relative  $F$ s. To be consistent with other analyses presented herein, the terminal year for estimation of relative  $F$  was the 2021 fishing year (September 1, 2021 – August 31, 2022), though index and catch data was available for the 2022 fishing year. Sensitivity analyses suggested exclusion of data from the 2022 fishing year in estimation of relative  $F$  did not substantially change catch advice.

#### 6.4.2 Results

For the northern stock, the relative  $F$  using the NC\_GillNet survey was calculated at 175.7. The annual catch:index ratio exceeded the relative  $F$  from 2015-2021 (Table 83 and Figure 197). The combined commercial and recreational catches in the northern stock have exceeded the recommended catch in six of the past seven years (Figure 198). The Skate method calculated an average proportional reduction in catch of 0.228 has been needed for 2015 through 2021 (Table 83 and Figure 199).

The relative  $F$  for the southern stock using the SC\_Trammel survey (ages-2 and -3 only) and South Carolina recreational catch was calculated at 98.02. The annual catch:Index ratio exceeded the relative  $F$  since 2010 (Table 84 and Figure 200), over the six-year management trigger used in the TLA. The South Carolina recreational catch has exceeded the recommended catch for the last 12 years when including preliminary data available for the 2022 fishing year (Table 84 and Figure 201). The Skate method calculated an average proportional reduction in catch of 0.669 has been needed across the 2012 to 2021 fishing years (Table 84 and Figure 202).

The relative  $F$  for the southern stock using the FL\_183\_HaulSeine survey was calculated at 218,231. The annual catch:index ratio exceeded the relative  $F$  from 2013 to 2021 (Table 85 and Figure 200). Based on the six-year management trigger, management actions would be needed using this method. The Florida recreational catch has exceeded the recommended catch for the last 9 years (Table 85 and Figure 203). The Skate method calculated an average proportional

reduction in catch of 0.476 has been needed for 2012 through 2021 fishing years (Table 85 and Figure 202).

## **7 STOCK STATUS**

### **Northern Stock**

Due to uncertainty and instability in the northern stock SS model, the model was not deemed satisfactory for stock status determination. However, it should be noted that results showing increasing trends in F coincide with increasing F trends observed in both the TLA analysis and Skate method.

The TLA, used for this stock as the primary stock status determination methodology, established that the northern stock is neither experiencing overfishing nor is the stock overfished. There is some level of uncertainty within this analysis, as the TLA for this stock appears to be heavily influenced by observations of a strong year class in 2011. However, this effect is decreasing in the most recent years as all three metrics are near exceeding TLA thresholds by the terminal year of the assessment. Overfishing is defined by fishery performance, the threshold for which is a red indicator in any one of the last three terminal years. In the case of the northern stock, the TLA has shown yellow indicators for all three of the terminal three years, suggesting levels of moderate action from management. However, fishery performance has been showing increasing proportions of red since the mid-2000s. Specifically, six of the seven previous years that have available data have shown some proportions of red (2016-2022), while only one year (2011) was red from 2003-2015, with three years (2003-2005) being green. This trend points to increased fishing effort across the northern stock, consistently approaching threshold values. Per the TLA reference points, an overfished status is only triggered when adult abundance is also red in any one of three previous years. For the northern stock, an overfished status was not determined as none of the three terminal years were at red (elevated action) levels. Similar to fishery performance, adult abundance is being shown to trend towards yellow and red designations in recent years. Specifically, the period of 2019 to 2022 has shown two years in the yellow designation and the terminal year (2022) in red. This contrasts with the period from 2012 to 2018 in which six of the years were green with only one year in yellow. As mentioned, when discussing the southern stock, any indication of a trend of decreasing adult abundance or increasing proportions of red values in the fishery performance metric should be considered by management. The life history of red drum is such that should these values exceed the thresholds established in this report, it will likely take a long period of corrective management to return these values to acceptable levels.

The Skate method was used for the northern stock as a complementary analysis to the TLA and as a means to provide quantitative catch advice, should it be needed. This method identified an extended period of overfishing utilizing the NC\_GillNet survey index and regional catch data. This methodology indicated that F values have been steadily increasing since the beginning of the time series (2005), finally exceeding the overfishing threshold for the stock in 2015. To prevent this designation, a relative decrease in catch on the order of 23% would have been needed in the northern stock since approximately 2015. The Skate analysis represents a more

risk adverse (e.g., lower risk) approach to management due to its shorter integration period (3 years) vs. the longer integration period needed for the TLA (7 years for fishery performance and 10 years for adult abundance). All three analyses suggest recent increasing trends in F. The northern stock is still data limited throughout the entire range, most noticeably north of North Carolina. This lack of data leads to increased stock uncertainty, further fueled by the trend of increasing catch in Virginia.

### **Southern Stock**

The SS model is the preferred tool for stock status determination for the southern stock. The model revealed overall decreasing SPR and relative SSB values in the recent years of the assessment. In fact, the model indicates that both values in the southern stock are now approaching levels last observed in the early to mid-1980s. Both annual SPR and three-year average SPR have been showing decreasing trends for much of the time period referenced in this report. Since approximately 2013, overfishing has been occurring with this stock as indicated by the SPR values, which have dropped below the threshold value of 30% and have remained there through the terminal year (2021). Similarly, trends in the SSB values for the southern stock have shown a decreasing pattern since approximately 2008. The recent indicators show that the stock has been overfished since approximately 2018, with SSB values dropping below the 30% threshold and remaining there through the terminal year. Although not defined in previous assessments, a 30% threshold for SSB was established in this report due to its association with the SPR threshold.

The TLA, in this case used as a complementary method to the SS model, corroborated much of the results revealed using the SS model. Using the TLA, overfishing is defined by fishery performance, the threshold for which is a red indicator in any one of the last three terminal years. In the case of the southern stock, the TLA has shown red indicators for all three of the terminal assessment years, indicating the stock has been experiencing overfishing since approximately 2018. However, where the TLA differs from the SS method is in the determination of the overfished status. Per the TLA reference points, an overfished status is only triggered when adult abundance is also red in any one of three previous years. Per this analysis, an overfished status was not determined as the three terminal years were not at red (elevated action) levels. A primary cause of this discrepancy is likely the inclusion of the GA\_Longline survey index in the TLA and the exclusion of this index from the SS model. The GA\_Longline survey index provides a conflicting trend with the SC\_Longline\_contemporary survey index, which led to the GA\_Longline survey index being excluded from the SS model. However, adult abundance has been at yellow (moderate action) levels since 2018. Further, two additional management triggers using adult abundance in combination with fishery performance and recruitment as the reference points did trigger using this analysis. The criteria of these triggers are 1) both fishery performance and adult abundance are yellow (or red) in any of the last three years and 2) recruitment has been red for five consecutive years and adult abundance has been yellow in any of the past three years. The first trigger indicates signs of increasing catch and/or decreasing sub-adult abundance. The second trigger is a sign of consistent, below average recruitment, which indicates increasing chances of future declines in adult abundance. These secondary triggers are especially important for a long-lived species like

red drum, where continued trends of decreased adult abundance and poor recruitment indicate the need for corrective management long before adult abundance reaches the red threshold levels.

Two additional complementary analyses were conducted, the Skate method and the Cormack-Jolly-Seber model, both of which identified increasing trends in F in recent years and an extended period of non-sustainable catch in the case of the Skate method. The Skate method identified an extended period of overfishing utilizing data from both the SC\_Trammel and FL\_183\_HaulSeine surveys, and regional catch data. In both states, this methodology indicated that overfishing has been occurring since the early 2010s, resulting in an overfishing designation for the stock since approximately 2012. In the case of Florida, a relative decrease in catch on the order of 48% would have been needed since 2012 to prevent this designation and South Carolina would have needed a 67% decreased relative catch to avoid overfishing. Similarly, the Cormack-Jolly-Seber Method has shown declining annual apparent survival in age-1 to -3 fish across the study period. This value is analogous to increasing levels of F and matches the observations from the SS, TLA, and Skate analyses (Figure 204).

## **8 FUTURE ASSESSMENTS AND RESEARCH RECOMMENDATIONS**

The SAS recommends conducting the next benchmark assessment in five years to allow for six additional fishing years (through 2027) of data past the terminal year in this assessment. The SAS does not recommend allowing a greater period between assessments due to the condition of the stocks in this assessment.

Before the next benchmark assessment, the SAS recommends updating the TLAs every two years, with the first update using the 2023 fishing year as the terminal year and the second update using the 2025 fishing year as the terminal year.

The SAS also encourages work on the following prioritized research recommendations (priority level bolded and italicized). Work on all high priority recommendations should commence immediately. Short-term recommendations are those that would take less time (1-5 years) to produce results to support future assessments. Long-term recommendations are those that will take a longer period of time (5-10+ years) to produce results to support future assessments.

### Short-Term

- Develop methods (e.g., voluntary logbook programs, catch cards, app reporting) to estimate recreational discard catch length composition coastwide. Several apps have been developed or are under development to provide these data, but quantity and quality of data collected still need to be assessed (*high*).
- Greater intensity of age sampling coastwide is needed for adults to better characterize year class strength when size-at-age overlaps considerably (*high*).

- Collect data to estimate movement rates (e.g., acoustic tagging) of sub-adults in inshore waters to the adult population in offshore/nearshore waters for development of a multi-area assessment model. NC has received funding for a satellite tagging study, but efforts are needed in all stock areas (*high*).
- Expand observer coverage to include other gears of concern (i.e., haul seine, purse seines, pound nets; *moderate*).
- Expand biostatistical sampling (ages and lengths) to better cover all statistical strata (gears/states/seasons) and collect more otolith ages proportional to lengths. Conduct statistical analysis to determine appropriate sample sizes to adequately characterize the age-size composition of removals. Greater sampling would support development of seasonal models (*moderate*).
- Determine batch fecundity estimates of red drum to support fecundity-based assessment. Age-specific spawning frequency and spawning season length needs to be included for this indeterminate spawner (*moderate*).
- Update maturity schedules for Atlantic red drum from Florida to Virginia. Preferably, gonad histology samples should be collected from all sizes over time and archived. South Carolina collects data, but data are needed from all other states (*moderate*).
- Continue and expand observer coverage for the NC and VA gill net fisheries to quantify total discards and size compositions with a goal of reaching CVs of 0.2 or less (*low*).
- Further study is needed to determine discard mortality estimates for the Atlantic coast, both for recreational and commercial gears. Additionally, discard estimates should examine the impact of slot-size limit management and explore regulatory discard impacts due to high-grading. Covariates affecting discard mortality (e.g., depth, size, seasonality, terminal tackle) should be investigated. Some work has been done to estimate discard mortality rates for adults in SC (*low*).
- Determine contributions of stocked fish to wild populations and their impacts to stock status for the southern stock. A data set of fin clips exist in SC that could be analyzed for this (*low*).
- Investigate reference points for red drum management. Potential to use operating model to do so (*low*).

#### Long-Term

- Expand tag-recapture analyses to states outside South Carolina. Further explore other tag-recapture models to use all available tag data (*high*).



- Index sub-adult abundance in VA inshore estuarine waters with non-trawl gears (e.g., seine or other net surveys; *high*)
- Develop longline surveys (with age sampling) targeting adult red drum at the northern and southern extents of the population range (*high*).
- Investigate a seasonal model to provide greater resolution on growth data (i.e., conditional age-at-length) within a fishing year. See work done during this assessment to evaluate data for supporting seasonal time steps (*high*).
- Incorporate tag-recapture data directly into assessment models used for stock status determination (*moderate*).
- Identify impacts of water quality, environmental, ecosystem, and habitat changes on red drum stock dynamics. Incorporate in stock assessment models (*moderate*).
- Investigate a two-area model that separates fish between inshore/offshore areas to better differentiate life history stages (older sub-adults vs. mature adults) that can't be as clearly separated by available data (i.e., lengths). Data to inform movement rates between areas will be needed which are essentially the same data to inform descending selectivity of the recreational fishery. Catch data will also need to be split into areas (*moderate*).

## 9 REFERENCES

- Atlantic Coastal Cooperative Statistics Program (ACCSP). 2016. Proceedings of the workshop on percent standard error (PSE) of recreational fishing data. Arlington, VA.
- Adams, D. H. and D. M. Tremain. 2000. Association of large juvenile red drum, *Sciaenops ocellatus*, with an estuarine creek on the Atlantic coast of Florida. *Environmental Biology of Fishes* 58: 183–194.
- Addis, D. 2020. The 2020 stock assessment of red drum, *Sciaenops ocellatus*, in Florida. Florida Fish and Wildlife Research Institute. IHR 2020-002. St. Petersburg, FL.
- Agresti, A. 2002. *Categorical Data*. Second Edition. Wiley
- Akaike, H. 1974. A new look at the statistical model identification. *IEEE Trans. Auto. Control* 19:716–723.
- Alverson, D. L. and M. J. Carney. 1975. A graphic review of the growth and decay of population cohorts. *Journal du Conseil / Conseil permanent International pour l'Exploration de la Mer* 36: 133-143.
- Anderson, S.C., C.C. Monnahan, K.F. Johnson, K. Ono, and J.L. Valero. 2014. ss3sim: An R package for fisheries stock assessment simulation with Stock Synthesis. *PLOS ONE*. 9(4): e92725. <http://doi.org/10.1371/journal.pone.0092725>.

- Arnott S.A., W.A. Roumillat, J.A. Archambault, C.A. Wenner, J.I. Gerhard, T.L. Darden, and M.R. Denson. 2010. Spatial synchrony and temporal dynamics of juvenile red drum *Sciaenops ocellatus* populations in South Carolina, USA. *Marine Ecology Progress Series* 415: 221-236.
- Arnott, S. 2015a. Red drum maturity analysis. SEDAR44-DW-02. SEDAR, North Charleston, SC.
- Arnott, S. 2015b. Distance moved by red drum recaptured by recreational anglers. SEDAR44-DW03. SEDAR, North Charleston, SC.
- Arnott, S. and L. Paramore. 2015. Sizes of tag recaptured red drum that were released alive by recreational anglers. SEDAR44-DW05. SEDAR. North Charleston, SC.
- ASMFC (Atlantic States Marine Fisheries Commission). 1984. Fisheries Management Report No. 5 of the Atlantic States Marine Fisheries Commission: Fishery Management Plan for Red Drum. Washington, DC. October 1984.
- ASMFC. 2002. Amendment 2 to the Interstate Fishery Management Plan for Red Drum; Fishery Management Report No. 38 of the Atlantic States Marine Fisheries Commission. ASMFC.
- ASMFC. 2003. Amendment 6 to the Interstate Fishery Management Plan for Atlantic Striped Bass. Atlantic States Marine Fisheries Commission. Washington, DC.
- ASMFC. 2008. Proceedings of an Atlantic Croaker and Red drum Ageing Workshop. Washington, D.C.
- ASMFC. 2017a. Amendment 3 to the Interstate Fishery Management Plan for Atlantic Menhaden. Atlantic States Marine Fisheries Commission. Arlington, VA.
- ASMFC. 2017b. Red Drum Benchmark Stock Assessment and Peer Review Report. Atlantic States Marine Fisheries Commission. Arlington, VA.
- ASMFC. 2020. Traffic Light Analysis of Atlantic croaker (*Micropogonias undulatus*). Atlantic States Marine Fisheries Commission. Arlington, VA.
- ASMFC. 2022. Red Drum Simulation Assessment and Peer Review Report. ASMFC. Arlington, VA.
- ASMFC. 2024. Fish habitat of concern designations for fish and shellfish species. Atlantic States Marine Fisheries Commission Habitat Committee, Arlington, VA.
- Bacheler, N.M., J.E. Hightower, L.M. Paramore, J.A. Buckel, and K.H. Pollock. 2008. An age-dependent tag return model for estimating mortality and selectivity of an estuarine dependent fish with high rates of catch and release. *Transactions of American Fisheries Society* 137: 1422-1432.

- Bacheler, N. M., L.M. Paramore, S.M. Burdick, J.A. Buckel, and J.E. Hightower. 2009. Variation in movement patterns of red drum *Sciaenops ocellatus* inferred from conventional tagging and ultrasonic tracking. *Fishery Bulletin* 107: 405-419.
- Bacheler, N.M., J.E. Hightower, S.M. Burdick, L. M. Paramore, J. A. Buckel, and K. H. Pollock. 2010. Using generalized linear models to estimate selectivity from short-term recoveries of tagged red drum *Sciaenops ocellatus*: Effects of gear, fate, and regulation period. *Fisheries Research* 102: 266-275.
- Baltz, D. M., J. W. Fleeger, C. F. Rakocinski, and J. N. McCall. 1998. Food, density, and microhabitat: Factors affecting growth and recruitment potential of juvenile saltmarsh fishes. *Environmental Biology of Fishes* 53: 89–103.
- Bass, R. J. and J. W. Avault Jr. 1975. Food habit, length-weight relationship, condition factor, and growth of juvenile red drum, *Sciaenops ocellatus*, in Louisiana. *Transactions of the American Fisheries Society* 104(1): 35–45.
- Baulier, L. and M. Heino. 2008. Norwegian spring-spawning herring as the test case of piecewise linear regression method for detecting maturation from growth patterns. *Journal of Fish Biology*, 73: 2451-2467.
- Beaumarrige, D. S. 1969. Returns from the 1965 Schlitz tagging program, including a cumulative analysis of previous results. Florida Department of Natural Resources Technical Series 59: 1–38.
- Beck, M. W., K. L. Heck, K. W. Able, D. L. Childers, D. B. Eggleston, B. M. Gillanders, B. Halpern, C. G. Hays, K. Hoshino, T. J. Minello, R. J. Orth, P. F. Sheridan, and M. P. Weinstein. 2001. The identification, conservation, and management of Estuarine and Marine Nurseries for Fish and Invertebrates. *BioScience* 51(8): 633–641.
- Beckwith, A. B., G. H. Beckwith, Jr., and P. S. Rand. 2006. Identification of critical spawning habitat and male courtship vocalization characteristics of red drum, *Sciaenops ocellatus*, in the lower Neuse River estuary of North Carolina. North Carolina Sea Grant Fishery Research Grant Program, Final Report 05-EP-05.
- Beddington, J.R. and J.G. Cooke. 1983. The potential yield of fish stocks. Food and Agriculture Organization fisheries technical paper 242: 1-47.
- Brown-Peterson, N.J., D.M. Wyanski, F. Saborido-Rey, B.J. Macewicz, and S.K. Lowerre-Barbieri. 2011. A standardized terminology for describing reproductive development in fishes. *Marine and Coastal Fisheries: Dynamics, Management, and Ecosystem Science* 3: 52-70.
- Buckley, J. 1984. Habitat suitability index models: Larval and juvenile red drum. U.S. Fish and Wildlife Service. pp. 1–25.

- Burdick, S. M., J. E. Hightower, J. A. Buckel, K. H. Pollock, and L. M. Paramore. 2007. Movement and selectivity of red drum and survival of adult red drum: an analysis of 20 years of tagging data. North Carolina Division of Marine Fisheries, Morehead City, NC.
- Caddy, J. F. 1998. A short review of precautionary reference points and some proposals for their use in data-poor situations. Food and Agriculture Organization fisheries technical paper 379.
- Caddy, J.F. 1999. Deciding on precautionary management measures for a stock based on a suite of limit reference points (LRPs) as a basis for a multi-LRP Harvest Law. Scientific council studies. Northwest Atlantic Fisheries Organization. Dartmouth NS 55–68.
- Caddy, J.F., Mahon, R. 1995. Reference points for fisheries management. Food and Agriculture Organization of the United Nations Rome.
- Caddy, J.F., E. Wade, T. Surette, M. Hebert, and M. Moriyasu. 2005. Using an empirical traffic light procedure for monitoring and forecasting in the Gulf of St. Lawrence fishery for the snow crab, *Chionoecetes opilio*. Fisheries Research 76: 123–145.  
<https://doi.org/10.1016/j.fishres.2005.06.003>
- Cadigan, N. 2009. Nonparametric growth model for Atlantic red drum, and changes to natural mortality (M) estimates. SEDAR Working Paper 18-AW02.
- Carvalho F., H. Winker, D. Courtney, M. Kapur, L. Kell, M. Cardinale, and M. Schirripa. 2021. A cookbook for using model diagnostics in integrated stock assessments. Fisheries Research 240: 105959.
- Chagaris, D., B. Mahmoudi, and M. Murphy. 2015. The 2015 stock assessment of red drum, *Sciaenops ocellatus*, in Florida. Florida Fish and Wildlife Research Institute. IHR-2015-003. St. Petersburg, FL.
- Chapman, R. W., A. O. Ball and L. R. Mash. 2002. Spatial homogeneity and temporal heterogeneity of red drum (*Sciaenops ocellatus*) microsatellites: Effective population sizes and management implications. Marine Biotechnology 4: 589-603.
- Charnov, E.L, H. Gislason, and J.G. Pope. 2013. Evolutionary assembly rules for fish life histories. Fish and Fisheries 14(2): 213-224.
- Chen, Y., M. Kanaiwa, and C. Wilson. 2005. Developing and evaluating a size-structured stock assessment model for the American lobster, *Homarus americanus*, fishery. New Zealand Journal of Marine and Freshwater Research 39(3): 645-660.
- Cochran, W.G. 1977. Sampling Techniques. 3rd Edition, John Wiley & Sons, New York.

- Comyns, B. H., J. Lyczkowski-Shultz, D. L. Nieland, and C. A. Wilson. 1991. Reproduction of red drum, *Sciaenops ocellatus*, in the Northcentral Gulf of Mexico: Seasonality and spawner biomass. U.S. Department of Commerce NOAA Technical Report NMFS 95: 17–26.
- Conn, P.B. 2010. Hierarchical analysis of multiple noisy abundance indices. *Canadian Journal of Fisheries and Aquatic Sciences* 67: 108-120.
- Crawley, M.J. 2007. *The R book*. John Wiley & Sons, Chichester, U.K.
- Cushing, D.H. 1975. *Marine ecology and fisheries*. Cambridge University Press, Cambridge, England.
- Cushman, E., M. Jamison, and T. Darden. 2014. Adult red drum genetic diversity and population structure. SEDAR Working Paper SEDAR44-DW01.
- Daniel, III, L. B. 1988. Aspects of the biology of juvenile red drum, *Sciaenops ocellatus*, and spotted seatrout, *Cynoscion nebulosus*, (Pisces: Sciaenidae) in South Carolina. M.S. Thesis. College of Charleston, Charleston, SC.
- Deroba, J.J., D.S. Butterworth, R.D. Methot, Jr., J.A.A. De Oliveira, C. Fernandez, A. Nielsen, S.X. Cadrin, M. Dickey-Collas, C.M. Legault, J. Ianelli, J.L. Valero, C.L. Needle, J.M. O'Malley, Y-J. Chang, G.G. Thompson, C. Canales, D.P. Swain, D.C.M. Miller, N.T. Hintzen, M. Bertignac, L. Ibaibarriaga, A. Silva, A. Murta, L.T. Kell, C.L. de Moor, A.M. Parma, C.M. Dichmont, V.R. Restrepo, Y. Ye, E. Jardim, P.D. Spencer, D.H. Hanselman, J. Blaylock, M. Mood, and P.J.F. Hulson. 2015. Simulation testing the robustness of stock assessment models to error: some results from the ICES strategic initiative on stock assessment methods. *ICES Journal of Marine Science* 72: 19–30.
- Francis, R.I.C.C. 2011. Data weighting in statistical fisheries stock assessment models. *Canadian Journal of Fisheries and Aquatic Sciences* 68(6): 1124–1138.
- FWCC (Florida Fish and Wildlife Conservation Commission). 2008. Red Drum, *Sciaenops ocellatus* stock assessment. Florida Fish and Wildlife Conservation Commission: Red Drum 61.
- Gimenez, O., Lebreton, J.-D., Choquet, R., & Pradel, R. (2018). R2ucare: An r package to perform goodness-of-fit tests for capture–recapture models. *Methods in Ecology and Evolution*, 9(7), 1749–1754. <https://doi.org/10.1111/2041-210X.13014>
- Gislason, H., N. Daan, J.C. Rice, and J.G. Pope. 2010. Size, growth, temperature and the natural mortality of marine fish. *Fish and Fisheries* 11(2): 149-158.
- Gold, J. R., C. P. Burrige, and T. F. Turner. 2001. A modified stepping-stone model of population structure in red drum, *Sciaenops ocellatus* (Sciaenidae), from the northern Gulf of Mexico. *Genetica* 111: 305-317.

- Gold, J. R. and T. F. Turner. 2002. Population structure of red drum (*Sciaenops ocellatus*) in the northern Gulf of Mexico, as inferred from variation in nuclear-encoded microsatellites. *Marine Biology* 140: 249-265.
- Goldberg, D. A., L. M. Paramore, and F. S. Scharf. 2021. Analysis of environment-recruitment associations for a coastal red drum population reveals consistent link between year class strength and early shifts in nearshore winds. *Fisheries Oceanography*: 1-14.  
<https://doi.org/10.1111/fog.12562>
- Gulland, J.A. 1983. *Fish Stock Assessment. A Manual of Basic Method*. FAO/Wiley Series on Food and Agriculture, Rome, 241 p.
- Haddon, M. 2011. *Modelling and Quantitative Methods in Fisheries*, second ed. CRC Press, Boca Raton.
- Halliday, R.G., L.P. Fanning, and R.K. Mohn. 2001. Use of the traffic light method in fishery management planning. *Canadian Science Advisory Secretariat*.
- Hamel, O.S., and Cope, J.M. 2022. Development and considerations for application of a longevity-based prior for the natural mortality rate. *Fish. Res.* 256. 106477.
- Hampton, J. 2000. Natural mortality rates in tropical tunas: size really does matter. *Canadian Journal of Fisheries and Aquatic Sciences*, 57(5), 1002-1010.
- Hewitt, D.A. and J.M. Hoenig. 2005. Comparison of two approaches for estimating natural mortality based on longevity. *Fishery Bulletin* 103: 433-437.
- Hilborn, R., and Walters, C.J. 1992. *Quantitative Fisheries Stock Assessment: Choice, Dynamics and Uncertainty*. Chapman & Hall, London, UK, p. 570.
- Hoenig, J.M. 1983. Empirical use of longevity data to estimate mortality rates. *Fishery Bulletin* 82: 898-903.
- Hoenig, J.M. 2017. Should natural mortality estimators based on maximum age also consider sample size? *Transactions of the American Fisheries Society* 146: 136-146.
- Hoenig, J. M., A. Y. Then, E. A. Babcock, N. G. Hall, D. A. Hewitt, and S. A. Hesp. 2016. The logic of comparative life history studies for estimating key parameters, with a focus on natural mortality rate. *ICES Journal of Marine Science* 73(10): 2453-2467.
- Holt, J., R. Godbout, and C. Arnold. 1981. Effects of temperature and salinity on egg hatching and larval survival of red drum *Sciaenops ocellatus*. *Fishery Bulletin* 79(3): 569–573.
- Holt S. A., C. L. Kitting, and C. R. Arnold. 1983. Distribution of young red drums among different sea-grass meadows. *Transactions of the American Fisheries Society* 112: 267–271.

- Holt, G. J., S. A. Holt, and C. R. Arnold. 1985. Diel periodicity of spawning in sciaenids. *Marine Ecology Progress Series* 27: 1–7.
- Holt, S. A., G. J. Holt, and C. R. Arnold. 1989. Tidal stream transport of larval fishes into non-stratified estuaries. *Rapports du Conseil International pour l'Exploration de la Mer* 191: 100–104.
- Houde E.D. 1987. Fish early life dynamics and recruitment variability. *American Fisheries Society Symposium* 2: 17-29.
- Hurtado-Ferro, F., C.S. Szuwalski, J.L. Valero, S.C. Anderson, C.J. Cunningham, K.F. Johnson, R. Licandeo, C.R. McGilliard, C.C. Monnahan, M.L. Muradian, K. Ono, K.A. Vert-Pre, A.R. Whitten, and A.E. Punt. 2014. Looking in the rear-view mirror: bias and retrospective patterns in integrated, age-structured stock assessment models. *ICES Journal of Marine Science* 72(1): 99–110.
- Jannke, T. 1971. Abundance of young sciaenid fishes in Everglades National Park, Florida, in relation to season and other variables. *University of Miami Sea Grant Technical Bulletin* 11.
- Jensen, A.L. 1996. Beverton and Holt life history invariants result from optimal trade-off of reproduction and survival. *Canadian Journal of Fisheries and Aquatic Sciences* 53: 820-822.
- Johnson, G. D. 1978. Development of fishes of the mid-Atlantic Bight. An atlas of egg, larval and juvenile stages. Vol IV. U.S. Fish and Wildlife Service, Biological Services Program. FSW/OBS-78/12: 190- 197.
- Johnson, D. R. and N. A. Funicelli. 1991. Estuarine spawning of the red drum in Mosquito Lagoon on the east coast of Florida. *Estuaries* 14: 74–79.
- Johnson, K.F., S.C. Anderson, K. Doering, C.C. Monnahan, C.C. Stawitz, and I.G. Taylor. 2021. ss3sim: Fisheries stock assessment simulation testing with Stock Synthesis. R package version 1.1.6.
- Jorde, P. E. and N. Ryman. 1995. Temporal allele frequency change and estimation of effective population size in populations with overlapping generations. *Genetics* 139: 1077-1090.
- Lo, N.C., L.D. Jacobson, and J.L. Squire. 1992. Indices of relative abundance from fish spotter data based on delta-lognormal models. *Canadian Journal Fisheries and Aquatic Sciences* 49: 2515-2526.
- Laake, J. L., Johnson, D. S., & Conn, P. B. (2013). marked: An R package for maximum likelihood and Markov Chain Monte Carlo analysis of capture–recapture data. *Methods in Ecology and Evolution*, 4(9), 885–890. <https://doi.org/10.1111/2041-210X.12065>

- Lebreton, J.-D., Burnham, K. P., Clobert, J., & Anderson, D. R. (1992). Modeling survival and testing biological hypotheses using marked animals: A unified approach with case studies. *Ecological Monographs*, 62(1), 67–118.
- Lenth, R.V. 2023. emmeans: Estimated marginal means, aka Least-Squares Means. R package version 1.8.5, <https://CRAN-R-project.org/package=emmeans>.
- Lorenzen, K. 1996. The relationship between body weight and natural mortality in juvenile and adult fish: a comparison of natural ecosystems and aquaculture. *Journal of Fish Biology* 49(4): 627-642.
- Lorenzen, K. 2000. Allometry of natural mortality as a basis for assessing optimal release size in fish-stocking programmes. *Canadian Journal of Fisheries and Aquatic Sciences* 57(12): 2734-2381.
- Lorenzen, K. 2005. Population dynamics and potential of fisheries stock enhancement: practical theory for assessment and policy analysis. *Philosophical Transactions of the Royal Society B* 360: 171-189.
- Lorenzen, K. 2022. Size- and age-dependent natural mortality in fish populations: Biology, models, implications, and a generalized length-inverse mortality paradigm. *Fish. Res.* 255, 106454.
- Lorenzen, K., Camp, E.V., and Garlock, T.M. 2022. Natural mortality and body size in fish populations. *Fish. Res.* 252, 106327.
- Lowerre-Barbieri, S.K., L.R. Barbieri, J.R. Flanders, A.G. Woodward, C.F. Cotton, and M.K. Knowlton. 2008. Use of passive acoustics to determine red drum spawning in Georgia waters. *Transactions of the American Fisheries Society* 137: 562-575.
- Luczkovich, J. J., H. J. Daniel, III, and M. W. Sprague. 1999. Characterization of critical spawning habitats of weakfish, spotted seatrout and red drum in Pamlico Sound using hydroplane surveys. Completion Report, F-62, NC Division of Marine Fisheries, Morehead City, NC.
- Lux, F.E. and J.V. Mahoney. 1969. First records of the channel bass, *Sciaenops ocellatus*, in the Gulf of Maine. *Copeia* 1969: 632–633.
- Lyczkowski-Shultz, J. and J. P. Steen, Jr. 1991. Diel vertical distribution of red drum *Sciaenops ocellatus* larvae in the northcentral Gulf of Mexico. *Fishery Bulletin* 89: 631–641.
- Mansueti, R. J. 1960. Restriction of very young red drum, (*Sciaenops ocellata*) to shallow estuarine waters of the Chesapeake Bay during late autumn. *Chesapeake Science* 1: 207–210.



- Marks Jr., R. E. and G. P. DiDomenico. 1996. Tagging studies, maturity, and spawning seasonality of red drum (*Sciaenops ocellatus*) in North Carolina. Completion Report Grant F-43, 1–39.
- Maunder, M.N., Hamel, O.S., Lee, H., Piner, K.R., Cope, J.M., Punt, A.E., Ianelli, J.N., Castillo-Jordan, C., Kapur, M.S., and Methot, R.D. 2023. A review of estimation methods for natural mortality and their performance in the context of fishery stock assessment. *Fish. Res.* 257, 106489.
- McGovern, J. C. 1986. Seasonal recruitment of larval and juvenile fishes into impounded and nonimpounded marshes. MS Thesis. College of Charleston, Charleston, SC.
- Mercer, L.P. 1984. A biological and fisheries profile of red drum, *Sciaenops ocellatus*. North Carolina Division of Marine Fisheries, Special Scientific Report 41, Morehead City.
- Methot, R.D. and I.G. Taylor. 2011. Adjusting for bias due to variability of estimated recruitments in fishery assessment models. *Canadian Journal of Fisheries and Aquatic Sciences* 68: 1744-1760.
- Methot, R.D. and C.R. Wetzel. 2013. Stock Synthesis: A biological and statistical framework for fish stock assessment and fishery management. *Fisheries Research*.  
<http://dx.doi.org/10.1016/j.fishres.2012.10.012>.
- Methot, R.D., C.R. Wetzel, I.G. Taylor, K.L. Doering, and K.F. Johnson. 2023. Stock Synthesis User Manual Version 3.30.21. NOAA Fisheries, Seattle, WA.
- Miles, D. W. 1950. The life histories of spotted seatrout, *Cynoscion nebulosus*, and the redfish, *Sciaenops ocellatus*. Texas Game, Fish and Oyster Commission, Marine Laboratory Annual Report (1949- 1950): 66–103.
- Minello, T. J. and G. W. Stunz. 2001. Habitat-related predation on juvenile wild-caught and hatchery-reared red drum *Sciaenops ocellatus* (Linnaeus). *Journal of Experimental Marine Biology and Ecology* 260: 13–25.
- Murphy, M.D. and R.G. Taylor. 1990. Reproduction, growth, and mortality of red drum *Sciaenops ocellatus* in Florida waters. *Fishery Bulletin* 88: 531-542.
- Murphy, M. D. 2017. An assessment of red drum in South Carolina, 1982-2016. SC DNR.
- Murphy, M. D. 2009. Reported commercial landings of red drum in Florida and estimated annual length and age composition. SEDAR-18-DW08 working paper.
- Music, J.F. and J.M. Pafford. 1984. Population dynamics and life history aspects of major marine sportfishes in Georgia coastal waters. Georgia Department of Natural Resources. Coastal Resources Division Cont. Ser. 38, Atlanta.

- NEFSC. 2020. Draft Report of the Index Based Methods Working Group. Northeast Fisheries Science Center, Woods Hole, MA. 59 pages.
- Neill, W. H. 1987. Environmental requirements of red drum. In: Chamberlain, G. W. (ed) Manual on Red Drum Aquaculture. Preliminary draft of invited papers presented at the Production Shortcourse of the 1987 Red Drum Aquaculture Conference on 22–24 June, 1987 in Corpus Christi, Texas. Texas A & M University, College Station, TX.
- Nelson, D. M., E. A. Irlandi, L. R. Settle, M. E. Monaco, and L. Coston-Clements. 1991. Distribution and abundance of fishes and invertebrates in southeast estuaries. ELMR Report No. 9, NOAA/NOS Strategic Environmental Assessments Division, Silver Spring, MD. pp. 167.
- Nelson, G. 2014. Cluster sampling: A pervasive, yet little recognized survey design in fisheries research. *Transactions of the American Fisheries Society* 143(4): 926-938.
- Nicholson, N. and S. R. Jordan. 1994. Biotelemetry study of red drum in Georgia. Georgia Department of Natural Resources, Brunswick, GA.
- Odell, J., D. H. Adams, B. Boutin, W. Collier II, A. Deary, L. N. Havel, J. A. Johnson Jr., S. R. Midway, J. Murray, K. Smith, K. M. Wilke, and M. W. Yuen. 2017. Atlantic Sciaenid habitats: A review of utilization, threats, and recommendations for conservation, management, and research. Atlantic States Marine Fisheries Commission Habitat Management Series No. 14, Arlington, VA.
- Ogle, D.H. 2018. Introductory Fisheries Analyses with R. Chapman and Hall/CRC.
- Ogle, D. H., Doll, J. C., Wheeler, A. P., & Dinno, A. (2023). *FSA: Simple Fisheries Stock Assessment Methods*. <https://CRAN.R-project.org/package=FSA>
- Osburn, H. R., G. C. Matlock, and A. W. Green. 1982. Red drum (*Sciaenops ocellatus*) movement in Texas bays. *Contributions in Marine Science* 25: 85–97.
- Pafford, J. M., A. G. Woodward, and N. Nicholson. 1990. Mortality, movement and growth of red drum in Georgia. Final report. Georgia Department of Natural Resources, Brunswick.
- Pattillo, M. E., T. E. Czapl, D. M. Nelson, and M. E. Monaco. 1997. Distribution and abundance of fishes and invertebrates in Gulf of Mexico estuaries, volume 2: species life history summaries. NOAA, NOS Strategic Environmental Assessments Division, Silver Spring, Maryland.
- Pauly, D. 1980. On the interrelationships between natural mortality, growth parameters, and mean environmental temperature in 175 fish stocks. *Journal du Conseil / Conseil permanent International pour l'Exploration de la Mer* 39: 175-192.

- Pearson, J. C. 1929. Natural history and conservation of the redfish and other commercial sciaenids on the Texas coast. *Bulletin of the U.S. Bureau of Fish Commission* 44: 129–214.
- Peters, K. M. and R. H. McMichael. 1987. Early life history of the red drum, *Sciaenops ocellatus* (Pisces: Sciaenidae), in Tampa Bay, Florida. *Estuaries* 10(2): 92–107.
- Pollock, K. H., Nichols, J. D., Brownie, C., & Hines, J. E. (1990). Statistical Inference for Capture-Recapture Experiments. *Wildlife Monographs*, 107, 3–97.
- Porch, C.E., C. A. Wilson, and D. L. Nieland. 2002. A new growth model for red drum (*Sciaenops ocellatus*) that accommodates seasonal and ontogenic changes in growth rates. *Fishery Bulletin* 100: 149-152.
- Pradel, R. (1993). Flexibility in survival analysis from recapture data: Handling trap-dependence. *Marked Individuals in the Study of Bird Populations*, 29–37.
- Pradel, R., Hines, J. E., Lebreton, J.-D., & Nichols, J. D. (1997). Capture-recapture survival models taking account of transients. *Biometrics*, 60–72.
- Pradel, R., Wintrebert, C. M., & Gimenez, O. (2003). A proposal for a goodness-of-fit test to the Arnason-Schwarz multisite capture-recapture model. *Biometrics*, 59(1), 43–53.
- Punt, A.E. 2017. Some insights into data weighting in integrated stock assessments. *Fisheries Research* 192: 52-65.
- Quinn, T.J., and Deriso, R.B. 1999. *Quantitative Fish Dynamics*. Oxford University Press.
- R Core Team. (2021). *R: A Language and Environment for Statistical Computing*. R Foundation for Statistical Computing. <https://www.R-project.org/>
- R Core Team. (2024). *R: A Language and Environment for Statistical Computing*. R Foundation for Statistical Computing. <https://www.R-project.org/>
- Renkas, B. J. 2010. Description of periodicity and location of red drum (*Sciaenops ocellatus*) spawning in Charleston Harbor, South Carolina. M.S. Thesis. College of Charleston, Charleston, SC.
- Reyier, E. A. and J. M. Shenker. 2007. Ichthyoplankton community structure in a shallow subtropical estuary of the Florida Atlantic Coast. *Bulletin of Marine Science* 80: 267-293.
- Reyier, E. A., R. H. Lowers, D. M. Scheidt, and D. H. Adams. 2011. Movement patterns of adult red drum, *Sciaenops ocellatus*, in shallow Florida lagoons as inferred through acoustic telemetry. *Environmental Biology of Fishes* 90: 343–360.

- Rooker, J. R. and S. A. Holt. 1997. Utilization of subtropical seagrass meadows by newly settled red drum *Sciaenops ocellatus*: Patterns of distribution and growth. Marine Ecology Progress Series 158: 139–149.
- Rooker, J.R., G.J. Holt, and S.A. Holt. 1998. Vulnerability of newly settled red drum (*Sciaenops ocellatus*) to predatory fish: is early-life survival enhanced by seagrass meadows? Marine Biology 131: 145–151.
- Rooker, J. R., S. A. Holt, G. J. Holt, and L. A. Fuiman. 1999. Spatial and temporal variability in growth, mortality, and recruitment potential of postsettlement red drum, *Sciaenops ocellatus*, in a subtropical estuary. Fishery Bulletin 97: 581–590.
- Ross, J. L. and T. M. Stevens. 1992. Life history and population dynamics of red drum (*Sciaenops ocellatus*) in North Carolina waters. Marine Fisheries Research. Completion Report, Project F-29. North Carolina Department of Marine Fisheries, Morehead City, NC.
- Ross, J. L., T. M. Stevens, and D. S. Vaughan. 1995. Age, growth, mortality, and reproductive biology of red drums in North Carolina waters. Transactions of the American Fisheries Society 124: 37-54.
- Sandercock, B. K., Murray, D., & Sandercock, B. (2020). Mark-recapture models for estimation of demographic parameters. Population Ecology in Practice, 157–190.
- Scott, R.D. and J. Heikkinen. 2012. Estimating age at first maturity in fish from change-points in growth rate. Marine Ecology Progress Series, 450:147-157.
- SEDAR (SouthEast Data, Assessment, and Review). 2009a. Stock assessment report for Atlantic red drum. Southeast Data, Assessment, and Review. North Charleston, South Carolina.
- SEDAR. 2009b. Overview of red drum tagging data and recapture results by state from Virginia to Florida. SEDAR18-DW02. SEDAR. North Charleston, SC.
- SEDAR. 2015a. SEDAR 44 – Atlantic red drum stock assessment report. SEDAR, North Charleston SC.
- SEDAR. 2015b. SEDAR procedural workshop 7: Data best practices. SEDAR, North Charleston SC.
- Setzler, E. M. 1977. A quantitative study of the movement of larval and juvenile Sciaenidae and Engraulidae into the estuarine nursery grounds of Doboy Sound, Sapelo Island, Georgia. M.S. Thesis. University of Georgia.
- SAFMC (South Atlantic Fisheries Management Council). 1998. Habitat plan for the south Atlantic region: Essential fish habitat requirements for fishery management plans of the South Atlantic Fishery Management Council. SAFMC, Charleston, SC.

- Seyoum, S., M. D. Tringali, and T. M. Bert. 2000. An analysis of genetic population structure in red drum, *Sciaenops ocellatus*, based on mtDNA control region sequences. *Fishery Bulletin* 98: 127-138.
- Shertzer, K. and P. Conn. 2012. Spawner-recruit relationships of demersal marine fishes: Prior distribution of steepness. *Bulletin of Marine Science* 88. 10.5343/bms.2011.1019.
- Simmons, E. G. and J. P. Breuer. 1962. A study of redfish, *Sciaenops ocellatus* (Linnaeus), and black drum, *Pogonias cromis* (Linnaeus). *Publications of the Institute of Marine Science* 8: 184–211.
- Stari, T., K.F. Preedy, E. McKenzie, W.S.C. Gurney, M.R. Heath, P.A. Kunzlik, & D.C. Spiers. 2010. Smooth age length keys: observations and implications for data collection on North Sea haddock. *Fish. Res.* 105(1): 2-12. <https://doi.org/10.1016/j.fishres.2010.02.004>.
- Stunz, G. W., T. J. Minello, and P. S. Levin. 2002. Growth of newly settled red drum *Sciaenops ocellatus* in different estuarine habitat types. *Marine Ecology Progress Series* 238: 227-236.
- Takade, H.M. and L.M. Paramore. 2007. Stock status of the northern red drum stock. North Carolina Division of Marine Fisheries, Morehead City.
- Then, A.Y., J.M. Hoenig, N.G. Hall, and D.A. Hewitt. 2015. Evaluating the predictive performance of empirical estimators of natural mortality rate using information on over 200 fish species. *ICES Journal of Marine Science* 72: 82–92.
- Tremain, D. M. and D. H. Adams. 1995. Seasonal variations in species diversity, abundance, and composition of fish communities in the northern Indian River Lagoon, Florida. *Bulletin of Marine Science* 57: 171–192.
- Troha, L. 2023. Estimating the tag-reporting rate and length-based selectivity of red drum (*Sciaenops ocellatus*) in South Carolina using a long-term tag-recapture study. M.S. Thesis, College of Charleston, Charleston, SC. 80 pp.
- Turner, T. F., L. R. Richardson, and J. R. Gold. 1999. Temporal genetic variation of mitochondrial DNA and the female effective population size of red drum (*Sciaenops ocellatus*) in the northern Gulf of Mexico. *Molecular Ecology* 8: 1223-1229.
- Vaughan, D. S. and T. E. Helser. 1990. Status of the red drum stock of the Atlantic coast: Stock assessment report for 1989. NOAA Technical Memorandum NMFS-SEFC-263, Beaufort Laboratory, Beaufort, NC.
- Vaughan, D. S. 1992. Status of the red drum stock of the Atlantic coast: Stock assessment report for 1991. NOAA Technical Memorandum NMFS-SEFC-297, Beaufort Laboratory, Beaufort, NC.

- Vaughan, D. S. 1993. Status of the red drum stock of the Atlantic coast: Stock assessment report for 1992. NOAA Technical Memorandum NMFS-SEFC-313, Beaufort Laboratory, Beaufort, NC.
- Vaughan, D. S. 1996. Status of the red drum stock of the Atlantic coast: Stock assessment report for 1995. NOAA Technical Memorandum NMFS-SEFC-380, Beaufort Laboratory, Beaufort, NC.
- Vaughan, D. S. and J. T. Carmichael. 2000. Analysis of Atlantic red drum: Northern and southern regions. National Oceanic and Atmospheric Administration Technical Memorandum NMFSSEFC-447.
- Vaughan, D. 2009. History of red drum assessments of the U.S. South Atlantic. SEDAR Working Paper 18-DW01.
- Venables, W.N. & B.D. Ripley. 2002. Modern Applied Statistics with S. Fourth Edition. Springer.
- Vetter, E.F. 1988. Estimation of natural mortality in fish stocks: a review. Fish. Bull. US 86, 25–43.
- Waples, R. S. 1989. A generalized approach for estimating effective population size from temporal changes in allele frequencies. Genetics 121: 379-391.
- Weinstein, M. P. 1979. Shallow marsh habitats as primary nurseries for fishes and shellfish, Cape Fear, North Carolina. Fishery Bulletin 77(2): 339–357.
- Wenner, C. A., W. A. Roumillat, J. Moran, M. B. Maddox, L. B. Daniel III, and J. W. Smith. 1990. Investigations on the life history and population dynamics of marine recreational fishes in South Carolina: Part 1. South Carolina Department of Natural Resources, Marine Resources Research Institute, Final Report Project F-37.
- Wenner, C. 1992. Red drum: Natural history and fishing techniques in South Carolina. Marine Resources Research Institute. Report No. 17.
- Wenner, C. A. 2000. Contributions to the biology of red drum *Sciaenops ocellatus*, in South Carolina. Final Report. National Marine Fisheries Service, St. Petersburg, Florida.
- Wilson, C.A. and D.L. Nieland. 1994. Reproductive biology of red drum, *Sciaenops ocellatus*, from the neritic waters of the northern Gulf of Mexico. Fishery Bulletin 92: 841-850.
- Wood, S.N. 2008. Fast stable direct fitting and smoothness selection for generalized additive models. Journal of the Royal Statistical Society (B). 70(3): 495-518.
- Wood, S.N. 2011. Fast stable restricted maximum likelihood and marginal likelihood estimation of semiparametric generalized linear models. Journal of the Royal Statistical Society (B). 73(1): 3-36.

- Wood, S.N. 2017. Generalized Additive Models: An Introduction with R (2<sup>nd</sup> edition). Chapman and Hall/CRC Press.
- Woodward, A. G. 1994. Tagging studies and population dynamics of red drum in coastal Georgia. Final Report. Georgia Department of Natural Resources, Brunswick, GA.
- Yokel, B. 1966. A contribution to the biology and distribution of the red drum, *Sciaenops ocellatus*. M.S. Thesis. University of Miami, Miami, FL.
- Zuur, A.F., E.N. Ieno, N.J. Walker, A.A. Saveliev, and G.M. Smith. 2009. Mixed effects models and extensions in ecology with R. Springer-Verlag, New York.
- Zuur, A.F., A.A. Saveliev, and E.N. Ieno. 2012. Zero inflated models and generalized linear mixed models with R. Highland Statistics Ltd. United Kingdom.

10 TABLES

Table 1. Red drum regulation timeline by jurisdiction for the northern stock.

Year	New Jersey	Delaware	Maryland	Potomac River	Virginia	North Carolina		
Pre-1960	No Regulations	No Regulations	No Regulations	No Regulations	No Regulations	No Regulations		
1960					No Regulations		No Regulations	No Regulations
1971								
1973								
1976								
1978								
1985								
1986								
1987								
1988								
1989	14" TL MLL; 2 fish >32" TL person <sup>-1</sup> day <sup>-1</sup>	14" TL MLL; 2 fish >32" TL person <sup>-1</sup> day <sup>-1</sup>	14" TL MLL	14" TL MLL; 2 fish >32" TL person <sup>-1</sup> day <sup>-1</sup>	14" TL MLL; 2 fish >32" TL person <sup>-1</sup> day <sup>-1</sup>			
1990					14-32" TL slot limit; 1 fish >32" TL; 5 fish person <sup>-1</sup> day <sup>-1</sup> recreational; 250,000 lb commercial cap			
1991	18" TL MLL; 1 fish >27" TL person <sup>-1</sup> day <sup>-1</sup>	18-27" TL slot limit; 5 fish person <sup>-1</sup> day <sup>-1</sup> with 1 fish allowed >27" TL person <sup>-1</sup> day <sup>-1</sup>	18" TL MLL; 5 fish person <sup>-1</sup> day <sup>-1</sup> with 1 fish allowed >27" TL person <sup>-1</sup> day <sup>-1</sup>	18" TL MLL; 1 fish >27" TL person <sup>-1</sup> day <sup>-1</sup>	18-27" TL slot limit; 5 fish person <sup>-1</sup> day <sup>-1</sup> with 1 fish allowed >27" TL person <sup>-1</sup> day <sup>-1</sup>	18-32" TL slot limit; 1 fish >32" TL; 5 fish person <sup>-1</sup> day <sup>-1</sup> recreational; 250,000 lb commercial cap		
1992								
1993								
1994								
1995								
1996								
1997								
1998								
1999								
2000						18-27" TL slot limit; 1 fish >27" TL person <sup>-1</sup> day <sup>-1</sup>	20-27" TL slot limit; 5 fish person <sup>-1</sup> day <sup>-1</sup>	18-27" TL recreational slot limit & 1 fish person <sup>-1</sup> day <sup>-1</sup> recreational limit; 18-25" TL commercial slot limit & 5 fish person <sup>-1</sup> day <sup>-1</sup> commercial limit
2001								
2002								
2003								
2004								
2005								
2006								
2007								
2008								
2009								
2010	18-26" TL recreational slot limit & 3 fish person <sup>-1</sup> day <sup>-1</sup> recreational limit; 18-25" TL commercial slot limit & 5 fish person <sup>-1</sup> day <sup>-1</sup> commercial limit	18-27" TL slot limit; 1 fish person <sup>-1</sup> day <sup>-1</sup> recreational; 250,000 lb commercial cap & 0-10 fish commercial trip limit (set by commission proclamation) with red drum not exceeding 50% total marketable catch (excluding menhaden)	18-25" TL slot limit; 5 fish person <sup>-1</sup> day <sup>-1</sup>	18-26" TL slot limit; 3 fish person <sup>-1</sup> day <sup>-1</sup>	18-26" TL slot limit; 3 fish person <sup>-1</sup> day <sup>-1</sup>	18-27" TL slot limit; 1 fish person <sup>-1</sup> day <sup>-1</sup> recreational; 250,000 lb commercial cap & 0-10 fish commercial trip limit (set by commission proclamation) with red drum not exceeding 50% total marketable catch (excluding menhaden)		
2011								
2012								
2013								
2014								
2015								
2016								
2017								
2018								
2019								
2020								
2021								
2022								



**Table 2. Red drum regulation timeline by jurisdiction for the southern stock.**

Year	South Carolina	Georgia	Florida
Pre-1925	No Regulations	No Regulations	No commercial use by out of state citizens
1925			12" FL MLL
1953			15" FL MLL
1955			12" FL MLL
1960			12" TL MLL
1971			12" FL MLL
1973			18" TL MLL; 1 fish >32" TL; protected species <sup>a</sup>
1976			18" TL MLL; 1 fish >32" TL; March-April closure <sup>b</sup>
1978			Moratorium
1985			14" TL MLL; 20 fish person <sup>-1</sup> day <sup>-1</sup> & 1 fish >32" person <sup>-1</sup> day <sup>-1</sup> ; commercial harvest prohibited
1986	14" TL MLL from June 1-Sept. 1; 1 fish >32" person <sup>-1</sup> day <sup>-1</sup>	14" TL MLL; 2 fish >32" TL person <sup>-1</sup> day <sup>-1</sup>	Moratorium
1987	14" TL MLL from June 1-Sept. 1; 1 fish >32" person <sup>-1</sup> day <sup>-1</sup> ; commercial harvest prohibited		14" TL MLL; 20 fish person <sup>-1</sup> day <sup>-1</sup> & 1 fish >32" person <sup>-1</sup> day <sup>-1</sup> ; commercial harvest prohibited
1988	14" TL MLL; 20 fish person <sup>-1</sup> day <sup>-1</sup> & 1 fish >32" person <sup>-1</sup> day <sup>-1</sup> ; commercial harvest prohibited	14" TL MLL; 2 fish >32" TL person <sup>-1</sup> day <sup>-1</sup> ; 10 fish person <sup>-1</sup> day <sup>-1</sup>	18" TL MLL; 1 fish >32" TL; March-April closure <sup>b</sup>
1989	14" TL MLL; 20 fish person <sup>-1</sup> day <sup>-1</sup> & 1 fish >32" person <sup>-1</sup> day <sup>-1</sup> ; commercial harvest prohibited		18" TL MLL; 1 fish >32" TL; March-April closure <sup>b</sup>
1990	14" TL MLL; 5 fish person <sup>-1</sup> day <sup>-1</sup> & 1 fish >32" person <sup>-1</sup> day <sup>-1</sup> ; commercial harvest prohibited	14" TL MLL; 5 fish person <sup>-1</sup> day <sup>-1</sup>	Moratorium
1991	14" TL MLL; 5 fish person <sup>-1</sup> day <sup>-1</sup> & 1 fish >32" person <sup>-1</sup> day <sup>-1</sup> ; commercial harvest prohibited		18-27" TL slot limit; March-May closed season; 1 fish person <sup>-1</sup> day <sup>-1</sup> ; prohibition on sale <sup>c</sup>
1992	14-27" TL slot limit; 5 fish person <sup>-1</sup> day <sup>-1</sup> ; commercial harvest prohibited	14-27" TL slot limit; 5 fish person <sup>-1</sup> day <sup>-1</sup>	18-27" TL slot limit; 1 fish person <sup>-1</sup> day <sup>-1</sup> ; prohibition on sale
1993			
1994			
1995			
1996			
1997			
1998			
1999			
2000			
2001			
2002	15-24" TL slot limit; 2 fish person <sup>-1</sup> day <sup>-1</sup> ; commercial harvest prohibited	14-23" TL slot limit; 5 fish person <sup>-1</sup> day <sup>-1</sup>	18-27" TL slot limit; 1 fish person <sup>-1</sup> day <sup>-1</sup> ; prohibition on sale
2003			
2004			
2005			
2006			
2007	15-23" TL slot limit; 3 fish person <sup>-1</sup> day <sup>-1</sup> ; commercial harvest prohibited	14-23" TL slot limit; 5 fish person <sup>-1</sup> day <sup>-1</sup>	18-27" TL slot limit; 1 fish person <sup>-1</sup> day <sup>-1</sup> ; prohibition on sale
2008			
2009			
2010			
2011			
2012	14-23" TL slot limit; 5 fish person <sup>-1</sup> day <sup>-1</sup> ; commercial sale prohibited	18-27" TL slot limit; 2 fish person <sup>-1</sup> day <sup>-1</sup> in NE (Atlantic) and NW (Gulf) regions; 1 fish person <sup>-1</sup> day <sup>-1</sup> for south region; prohibition on sale	
2013			
2014			
2015			
2016			
2017	15-23" TL slot limit; 2 fish person <sup>-1</sup> day <sup>-1</sup> & 6 fish boat <sup>-1</sup> day <sup>-1</sup> ; commercial harvest prohibited	14-23" TL slot limit; 5 fish person <sup>-1</sup> day <sup>-1</sup> ; commercial sale prohibited	18-27" TL slot limit; 1 fish person <sup>-1</sup> day <sup>-1</sup> & 4 fish vessel limit in NE region; 0 fish person <sup>-1</sup> day <sup>-1</sup> & 0 fish vessel limit in Indian River Lagoon region; 1 fish person <sup>-1</sup> day <sup>-1</sup> & 2 fish vessel limit in SE region; prohibition on sale
2018			
2019			
2020			
2021			
2022			

a - harvest moratorium from 11/7/86-2/17/1987

b - harvest moratorium from 5/1-10/1/1987; reopened 10/1/1987 with 18-27" TL slot limit, 5 fish commercial possession limit & 1 fish recreational possession limit

c - prohibited gigging and spearing on 6/3/1991 (still in effect)

**Table 3. Von Bertalanffy growth parameters estimated for red drum captured in North Carolina from north of the White Oak River (North), within and south of the White Oak River (South), and all individuals combined (Pooled).**

<b>Parameter</b>	<b>North</b>	<b>South</b>	<b>Pooled</b>
<i>L<sub>inf</sub></i>	1165	1066	1165
<i>K</i>	0.22	0.32	0.23
<i>t<sub>0</sub></i>	-0.739	-0.217	-0.755

**Table 4. Von Bertalanffy growth parameters estimated for red drum captured in North Carolina from within and south of the White Oak River (south), South Carolina (SC), and all individuals combined (Pooled).**

<b>Parameter</b>	<b>South</b>	<b>SC</b>	<b>Pooled</b>
<i>L<sub>inf</sub></i>	1066	1030	1030
<i>K</i>	0.316	0.249	0.249
<i>t<sub>0</sub></i>	-0.217	-0.505	-0.513



**Table 6. Number of red drum age samples collected by state within the Atlantic coast of the U.S. from 1981 – 2022. The variable ‘MULTI’ refers to several fishery independent surveys (e.g., ChesMMAP, NEAMAP) whose sampling universe spans multiple states; they operate in the northern stock.**

Year	Age (yrs)						Total
	FL	GA	SC	NC	VA	MULTI	
1981	312	0	0	0	0	0	312
1982	187	0	0	0	0	0	187
1984	0	0	1	0	0	0	1
1985	0	0	140	0	0	0	140
1986	0	0	943	0	0	0	943
1987	0	0	393	142	0	0	535
1988	0	0	305	367	0	0	672
1989	0	0	614	452	0	0	1066
1990	0	0	820	575	0	0	1395
1991	0	0	673	1970	0	0	2643
1992	0	0	357	938	0	0	1295
1993	0	0	518	1748	0	0	2266
1994	0	0	391	725	0	0	1116
1995	0	0	317	996	0	0	1313
1996	0	13	453	638	0	0	1104
1997	0	345	340	1615	0	0	2300
1998	0	334	317	1600	43	0	2294
1999	0	237	196	656	92	0	1181
2000	41	141	1089	933	53	0	2257
2001	108	197	749	417	30	0	1501
2002	96	633	926	613	29	0	2297
2003	117	462	460	755	26	0	1820
2004	131	215	403	2203	1	0	2953
2005	155	345	330	1760	25	0	2615
2006	172	154	579	1085	52	7	2049
2007	143	291	590	1052	74	1	2151
2008	97	15	864	1038	127	0	2141
2009	116	0	951	717	56	6	1846
2010	113	0	705	1093	19	5	1935
2011	171	0	606	1301	9	9	2096
2012	174	0	540	1297	71	8	2090
2013	281	81	407	822	133	5	1729
2014	242	241	381	874	63	8	1809
2015	166	270	637	1380	6	5	2464
2016	188	343	623	2096	53	6	3309
2017	179	448	699	1556	53	9	2944
2018	166	452	489	2616	12	0	3735
2019	109	469	252	2169	46	0	3045
2020	113	352	424	636	109	0	1634
2021	221	203	335	755	114	12	1640
2022	66	0	132	295	34	5	532
Total	3864	6241	19949	39885	1330	86	71355
Percent	0.054	0.087	0.280	0.559	0.019	0.001	

**Table 7. Number of red drum age samples collected by fishery dependent and fishery independent sources on the Atlantic coast of the U.S. from 1981 – 2022.**

Year	Fishery Dependent	Fishery Independent
1981	312	0
1982	187	0
1984	0	1
1985	0	140
1986	81	862
1987	148	387
1988	265	407
1989	343	723
1990	290	1105
1991	376	2267
1992	518	777
1993	363	1903
1994	239	877
1995	554	759
1996	463	641
1997	1010	1290
1998	958	1335
1999	717	464
2000	711	1544
2001	497	1004
2002	732	1563
2003	499	1320
2004	445	2508
2005	741	1874
2006	554	1495
2007	428	1723
2008	235	1868
2009	157	1689
2010	144	1791
2011	114	1982
2012	202	1888
2013	333	1396
2014	363	1446
2015	337	2127
2016	519	2790
2017	663	2265
2018	618	3117
2019	695	2350
2020	801	833
2021	592	1048
2022	143	389
Total	17347	53948
Percent	0.243	0.757

**Table 8. Length-at-maturity as estimated using logistic regressions fit to histologically derived maturity status information from South Carolina (SCDNR) and North Carolina (Ross et al. 1995 and NCDMF Study). Total lengths were measured to the nearest mm TL. As data was only available from one state in each stock (South Carolina = Southern; North Carolina = Northern), these analyses represent maturity ogives for the respective stock. Parameters a and b ( $\pm$ SE) are for the logistic function  $Prop. Mat. = e^Z / (1 + e^Z)$  where  $Z = a + b * TL$ . 50% maturity represents the total length where proportion mature equals 0.5 with 95% CI of estimate in parentheses. Also provided are the maturity ogives and 50% maturities as presented in SEDAR 44 for reference.**

Sex	Stock	n	a	$\pm$ SE	b	$\pm$ SE	50% maturity	Source
Female	Southern	1805	-17.893	1.1302	0.022806	0.0014545	784.6	SEDAR 44*
	Northern	305	-38.840	7.3701	0.044512	0.0085605	872.6	SEDAR 44*
	Southern	1132	-16.282	1.0945	0.021265	0.0013822	766 (753 - 778)	Current Study
	Northern	435	-28.824	4.1943	0.034490	0.0050720	836 (818 - 853)	Current Study
Male	Southern	2927	-18.379	1.1419	0.026493	0.0016986	693.7	SEDAR 44*
	Northern	340	-19.801	3.7656	0.029440	0.0054736	672.6	SEDAR 44*
	Southern	941	-10.008	0.6711	0.014865	0.0009597	673 (658 - 688)	Current Study
	Northern	340	-17.266	3.0748	0.027354	0.0047262	631 (611 - 651)	Current Study

\* - Calculations assumed a Jan 1 birth date

**Table 9. Age-at-maturity as estimated using logistic regressions fit to histologically derived maturity status information from South Carolina (SCDNR) and North Carolina (Ross et al. 1995 and NCDMF Study). Ages (in yrs) fit were age to the nearest month, assuming a September 1 birthday. As data was only available from one state in each stock (South Carolina = Southern; North Carolina = Northern), these analyses represent maturity ogives for the respective stock. Parameters a and b ( $\pm$ SE) are for the logistic function  $Prop. Mat. = e^Z / (1 + e^Z)$  where  $Z = a + b * Age$ . 50% maturity represents the age where proportion mature equals 0.5 with 95% CI of estimate in parentheses. Also provided are the maturity ogives and 50% maturities as presented in SEDAR 44 for reference.**

Sex	Stock	n	a	$\pm$ SE	b	$\pm$ SE	50% maturity	Source
Female	Southern	2613	-9.075	0.4540	1.792	0.1074	5.1	SEDAR 44*
	Northern	334	-29.874	6.0502	7.276	1.5721	4.1	SEDAR 44*
	Southern	1119	-6.539	0.4999	1.546	0.1292	4.2 (4.0 - 4.4)	Current Study
	Northern	398	-15.165	2.2199	4.281	0.6650	3.5 (3.4 - 3.7)	Current Study
Male	Southern	2930	-10.122	0.4524	2.427	0.1250	4.2	SEDAR 44*
	Northern	318	-10.815	1.8889	3.666	0.6153	2.9	SEDAR 44*
	Southern	938	-4.068	0.3442	1.207	0.1079	3.4 (3.2 - 3.6)	Current Study
	Northern	318	-8.372	1.4670	3.748	0.6237	2.2 (2.1 - 2.4)	Current Study

\* - Calculations assumed a Jan 1 birth date

**Table 10. Predicted proportion mature by 20 mm TL bin for the southern and northern stock as estimated in SEDAR44 and the current assessment for female red drum.**

Total Length	Southern		Northern	
	SEDAR 44	Current	SEDAR 44	Current
<300	0.00	0.00		
300	0.00	0.01		
320	0.00	0.01		
340	0.00	0.01		
360	0.01	0.02		
380	0.01	0.03		
400	0.02	0.04	0.00	0.00
420	0.02	0.06	0.00	0.00
440	0.04	0.10	0.00	0.00
460	0.06	0.15	0.00	0.00
480	0.10	0.23	0.00	0.00
500	0.15	0.35	0.00	0.00
520	0.24	0.54	0.00	0.00
540	0.38	0.82	0.00	0.00
560	0.59	1.24	0.00	0.01
580	0.93	1.89	0.00	0.01
600	1.46	2.87	0.00	0.03
620	2.29	4.32	0.00	0.06
640	3.57	6.46	0.00	0.12
660	5.51	9.56	0.10	0.23
680	8.43	13.92	0.02	0.46
700	12.69	19.84	0.05	0.92
720	18.65	27.46	0.11	1.81
740	26.57	36.68	0.27	3.55
760	36.34	46.99	0.66	6.84
780	47.39	57.56	1.60	12.77
800	58.71	67.48	3.80	22.58
820	69.17	76.05	8.79	36.77
840	77.97	82.93	19.00	53.68
860	84.81	88.14	36.36	69.79
880	89.81	91.92	58.19	82.16
900	93.29	94.57	77.22	90.18
920	95.64	96.38	89.20	94.82
940	97.19	97.60	95.26	97.33
960	98.20	98.42	98.00	98.64
980	98.85	98.96	99.17	99.31
1000	99.27	99.32	99.66	99.66
1020	99.54	99.55	99.86	99.83
1040	99.71	99.71	99.94	99.91
1060	99.81	99.81	99.98	99.96
1080	99.88	99.88	99.99	99.98
1100	99.92	99.92	100.00	99.99
1120	99.95	99.95	100.00	99.99
1140	99.97	99.97	100.00	100.00
1160	99.98	99.98	100.00	100.00
1180	99.99	99.99	100.00	100.00
≥1200			100.00	100.00



**Table 11. Predicted proportion mature by age for the southern and northern stock as estimated in SEDAR44 and the current assessment for female red drum. Note, this is proportion mature on a given birthday, which was assumed to be January 1 in SEDAR 44 and September 1 in the current assessment. This, along with the new data, led to a higher percentage of younger age red drum being mature in the current assessment.**

Age	Southern		Northern	
	SEDAR 44	Current	SEDAR 44	Current
0	0.01	0.14	0.00	0.00
1	0.70	0.67	0.00	0.00
2	0.41	3.09	0.00	0.14
3	2.42	13.00	0.03	8.93
4	12.93	41.22	31.65	87.64
5	47.13	76.69	99.85	99.81
6	84.25	93.92	100.00	100.00
7	96.98	98.64	100.00	100.00
8	99.48	99.71	100.00	100.00
9	99.91	99.94	100.00	100.00
10	99.99	99.99	100.00	100.00
11	100.00	100.00	100.00	100.00
12	100.00	100.00	100.00	100.00
13	100.00	100.00	100.00	100.00
14	100.00	100.00	100.00	100.00
15+	100.00	100.00	100.00	100.00

**Table 12. Number of actively spawning and mature females observed by SCDNR from mid-August through September and resultant probability of spawning, spawning frequency, and # of spawns assuming a 45-day spawning season for individual fish. Data was analyzed using only females captured in August, in September, and August and September combined.**

Month	Actively Spawning	Mature	Probability Spawning	Spawning Frequency (Days)	# of Spawns
August	7	29	0.2414	4	10.9
September	18	55	0.3273	3	14.7
August + September	25	84	0.2976	3	13.4

**Table 13. Correlation results for North Carolina Bag Seine Survey recruitment index and favorable wind indices from North Carolina State Climate Office station KHSE. Significant results (p-value<0.05) are bolded and italicized.**

Years	Period	r	p-value
1991-2022	Late July	0.01	0.968
1991-2022	Early August	0.22	0.228
1991-2016	Late August	0.45	<b><i>0.022</i></b>
1991-2022	Late August	0.32	0.072
1991-2022	August	0.31	0.085
1991-2022	Early September	0.19	0.293
1991-2022	Late September	-0.09	0.622
1991-2022	September	0.10	0.597
1991-2016	Early October	0.41	<b><i>0.039</i></b>
1991-2022	Early October	0.40	<b><i>0.022</i></b>
1991-2016	Seasonal	0.41	<b><i>0.036</i></b>
1991-2022	Seasonal	0.37	<b><i>0.039</i></b>

**Table 14. Correlation results for North Carolina Bag Seine Survey recruitment index and sea surface temperature indices from NOAA National Data Buoy Center Stations DSLN7 and 41025.**

Years	Period	r	p-value
1991-2016	Late July	0.24	0.240
1991-2022	Late July	0.20	0.267
1991-2022	Early August	0.09	0.626
1991-2022	Late August	-0.09	0.628
1991-2022	August	0.00	0.981
1991-2022	Early September	-0.11	0.550
1991-2022	Late September	0.02	0.900
1991-2022	Early October	0.02	0.919
1991-2022	September	-0.05	0.784
1991-2022	Seasonal	0.03	0.888

**Table 15. Correlation results for southern stock recruitment indices and favorable wind indices from NOAA National Data Buoy Center Stations 41004 (southeast of Charleston) and 41008 (southeast of Savannah). Significant results (p-value<0.05) are bolded and italicized.**

JAI	Buoy	Period	r	p-value
SC	41004	Early September	0.63	<b><i>0.007</i></b>
GA	41008	Early August	0.47	0.051
SC	41004	Early October	0.49	0.054
GA	41008	September	0.43	0.076
GA	41004	Late August	-0.48	0.085
GA	41008	Late September	0.42	0.096

**Table 16. Natural mortality-at-age,  $M(a)$ , or -weight,  $M(w)$ , of red drum in the northern ( $t_{max} = 62$ ) and southern ( $t_{max} = 41$ ) stocks. The ‘Mortality-weight’ model ( $M_w$ ) followed Lorenzen (1996). The ‘Length-inverse’ estimates of  $M_l$  followed Lorenzen (2022) using the Hamel and Cope (2022) constant  $M$  estimate. The ‘Length-inverse’ model scaled the cumulative mortality rate predicted for ages 2 – 62 and ages 2-41 to the longevity-based constant  $M$  estimates for the northern and southern stocks, respectively.**

Age (yr)	Length (mm)	Northern Stock		Length (mm)	Southern Stock	
		Lorenzen (1996)	Lorenzen (2022)		Lorenzen (1996)	Lorenzen (2022)
		$M_w$	$M_a$		$M_w$	$M_a$
0.5	195	0.349	0.498	165	0.517	0.749
1.5	436	0.177	0.223	383	0.25	0.322
2.5	615	0.132	0.158	528	0.19	0.233
3.5	748	0.112	0.13	646	0.16	0.191
4.5	854	0.1	0.114	740	0.142	0.167
5.5	938	0.092	0.103	816	0.131	0.151
6.5	979	0.089	0.099	854	0.125	0.144
7.5	991	0.088	0.098	866	0.124	0.142
8.5	1003	0.087	0.097	876	0.123	0.141
9.5	1015	0.087	0.096	887	0.122	0.139
10.5	1025	0.086	0.095	897	0.12	0.137
11.5	1036	0.085	0.094	906	0.119	0.136
12.5	1045	0.084	0.093	915	0.118	0.135
13.5	1055	0.084	0.092	924	0.117	0.133
14.5	1064	0.083	0.091	933	0.116	0.132
15.5	1072	0.083	0.09	941	0.116	0.131
16.5	1080	0.082	0.09	949	0.115	0.13
17.5	1088	0.082	0.089	956	0.114	0.129
18.5	1096	0.081	0.089	963	0.113	0.128
19.5	1103	0.081	0.088	970	0.113	0.127
20.5	1110	0.08	0.087	977	0.112	0.126
21.5	1116	0.08	0.087	983	0.111	0.125
22.5	1122	0.079	0.086	989	0.111	0.125
23.5	1128	0.079	0.086	995	0.11	0.124
24.5	1134	0.079	0.086	1000	0.11	0.123
25.5	1139	0.078	0.085	1006	0.109	0.123
26.5	1144	0.078	0.085	1011	0.109	0.122
27.5	1149	0.078	0.084	1016	0.108	0.121
28.5	1154	0.078	0.084	1021	0.108	0.121
29.5	1158	0.077	0.084	1025	0.107	0.12
30.5	1163	0.077	0.083	1029	0.107	0.12
31.5	1167	0.077	0.083	1034	0.107	0.119
32.5	1171	0.077	0.083	1038	0.106	0.119
33.5	1174	0.076	0.083	1041	0.106	0.118
34.5	1178	0.076	0.082	1045	0.106	0.118

Age (yr)	Length (mm)	Northern Stock		Length (mm)	Southern Stock	
		Lorenzen (1996)	Lorenzen (2022)		Lorenzen (1996)	Lorenzen (2022)
		M <sub>w</sub>	M <sub>a</sub>		M <sub>w</sub>	M <sub>a</sub>
35.5	1181	0.076	0.082	1049	0.105	0.118
36.5	1185	0.076	0.082	1052	0.105	0.117
37.5	1188	0.076	0.082	1055	0.105	0.117
38.5	1191	0.076	0.081	1058	0.104	0.117
39.5	1193	0.075	0.081	1061	0.104	0.116
40.5	1196	0.075	0.081	1064	0.104	0.116
41				1066	0.104	0.116
41.5	1199	0.075	0.081			
42.5	1201	0.075	0.081			
43.5	1203	0.075	0.081			
44.5	1206	0.075	0.08			
45.5	1208	0.075	0.08			
46.5	1210	0.075	0.08			
47.5	1212	0.074	0.08			
48.5	1214	0.074	0.08			
49.5	1215	0.074	0.08			
50.5	1217	0.074	0.08			
51.5	1219	0.074	0.08			
52.5	1220	0.074	0.079			
53.5	1222	0.074	0.079			
54.5	1223	0.074	0.079			
55.5	1225	0.074	0.079			
56.5	1226	0.074	0.079			
57.5	1227	0.074	0.079			
58.5	1228	0.074	0.079			
59.5	1229	0.074	0.079			
60.5	1230	0.074	0.079			
61.5	1231	0.073	0.079			
62	1232	0.073	0.079			

**Table 17. Commercial gear categories developed and used in past red drum SEDAR stock assessments for ACCSP gear codes.**

ACCSP Gear Code	ACCSP Gear Name	ACCSP Category Name	ACCSP Type Name	SEDAR Gear
20	OTHER SEINES	OTHER SEINES	HAUL SEINES	Beach Seine
60	FYKE NETS	FYKE NETS	FIXED NETS	Beach Seine
76	STOP NET	OTHER FIXED NETS	FIXED NETS	Beach Seine
130	POTS AND TRAPS	POTS AND TRAPS	POTS AND TRAPS	Gill Nets
131	POTS AND TRAPS, CONCH	POTS AND TRAPS	POTS AND TRAPS	Gill Nets
132	POTS AND TRAPS, BLUE CRAB	POTS AND TRAPS	POTS AND TRAPS	Gill Nets
136	POTS AND TRAPS, CRAB, PEELER	POTS AND TRAPS	POTS AND TRAPS	Gill Nets
137	POTS AND TRAPS, CRAYFISH	POTS AND TRAPS	POTS AND TRAPS	Gill Nets
138	POTS AND TRAPS, EEL	POTS AND TRAPS	POTS AND TRAPS	Gill Nets
139	POTS AND TRAPS, FISH	POTS AND TRAPS	POTS AND TRAPS	Gill Nets
140	POTS AND TRAPS, SPINY LOBSTER	POTS AND TRAPS	POTS AND TRAPS	Gill Nets
141	POTS AND TRAPS, OCTOPUS	POTS AND TRAPS	POTS AND TRAPS	Gill Nets
142	POTS AND TRAPS, PERIWINKLE OR CONKLE	POTS AND TRAPS	POTS AND TRAPS	Gill Nets
143	POTS AND TRAPS, SHRIMP	POTS AND TRAPS	POTS AND TRAPS	Gill Nets
144	POTS AND TRAPS, TURTLE	POTS AND TRAPS	POTS AND TRAPS	Gill Nets
145	POTS AND TRAPS, STONE CRAB	POTS AND TRAPS	POTS AND TRAPS	Gill Nets
146	POTS AND TRAPS, SCUP	POTS AND TRAPS	POTS AND TRAPS	Gill Nets
147	POTS AND TRAPS, BLACK SEA BASS	POTS AND TRAPS	POTS AND TRAPS	Gill Nets
148	POTS AND TRAPS, REEF FISH	POTS AND TRAPS	POTS AND TRAPS	Gill Nets
149	POTS AND TRAPS, HAGFISH	POTS AND TRAPS	POTS AND TRAPS	Gill Nets
150	POTS AND TRAPS, GOLDEN CRAB	POTS AND TRAPS	POTS AND TRAPS	Gill Nets
151	POTS AND TRAPS, PUFFER	POTS AND TRAPS	POTS AND TRAPS	Gill Nets
152	POTS, CRAB OTHER	POTS AND TRAPS	POTS AND TRAPS	Gill Nets
153	POTS AND TRAPS, MINNOW	POTS AND TRAPS	POTS AND TRAPS	Gill Nets
160	POTS AND TRAPS, LOBSTER	POTS & TRAPS, LOBSTER	POTS AND TRAPS	Gill Nets
161	POTS AND TRAPS, LOBSTER INSHORE	POTS & TRAPS, LOBSTER	POTS AND TRAPS	Gill Nets
162	POTS AND TRAPS, LOBSTER OFFSHORE	POTS & TRAPS, LOBSTER	POTS AND TRAPS	Gill Nets
163	POTS AND TRAPS, LOBSTER DOUBLE PARLOR	POTS & TRAPS, LOBSTER	POTS AND TRAPS	Gill Nets
164	POTS AND TRAPS, COLLAPSIBLE CRAB	POTS AND TRAPS	POTS AND TRAPS	Gill Nets
180	POTS AND TRAPS, OTHER	POTS & TRAPS, OTHER	POTS AND TRAPS	Gill Nets
181	POTS, UNCLASSIFIED	POTS & TRAPS, OTHER	POTS AND TRAPS	Gill Nets
200	GILL NETS	GILL NETS	GILL NETS	Gill Nets
201	GILL NETS, FLOATING DRIFT	GILL NETS	GILL NETS	Gill Nets
202	GILL NETS, SINK DRIFT	GILL NETS	GILL NETS	Gill Nets
203	GILL NETS, FLOATING ANCHOR	GILL NETS	GILL NETS	Gill Nets
204	GILL NETS, SINK ANCHOR	GILL NETS	GILL NETS	Gill Nets
205	GILL NETS, RUNAROUND	GILL NETS	GILL NETS	Gill Nets
206	GILL NETS, STAKE	GILL NETS	GILL NETS	Gill Nets
207	GILL NETS, OTHER	GILL NETS	GILL NETS	Gill Nets
208	GILL NETS, DRIFT, SMALL MESH	GILL NETS	GILL NETS	Gill Nets
209	GILL NETS, DRIFT, LARGE MESH	GILL NETS	GILL NETS	Gill Nets
210	TRAMMEL NETS	TRAMMEL NETS	GILL NETS	Gill Nets
211	TRAMMEL NETS, FLOATING DRIFT	TRAMMEL NETS	GILL NETS	Gill Nets
212	TRAMMEL NETS, SINK DRIFT	TRAMMEL NETS	GILL NETS	Gill Nets
213	TRAMMEL NETS, FLOATING ANCHOR	TRAMMEL NETS	GILL NETS	Gill Nets
214	TRAMMEL NETS, SINK ANCHOR	TRAMMEL NETS	GILL NETS	Gill Nets
215	TRAMMEL NETS, RUNAROUND	TRAMMEL NETS	GILL NETS	Gill Nets
216	TRAMMEL NETS, OTHER	TRAMMEL NETS	GILL NETS	Gill Nets
300	HOOK AND LINE	HOOK AND LINE	HOOK AND LINE	Hook and Line
301	HOOK AND LINE, MANUAL	HOOK AND LINE	HOOK AND LINE	Hook and Line
302	HOOK AND LINE, ELECTRIC	HOOK AND LINE	HOOK AND LINE	Hook and Line
303	ELECTRIC/HYDRAULIC, BANDIT REELS	HOOK AND LINE	HOOK AND LINE	Hook and Line
304	HOOK AND LINE, CHUM	HOOK AND LINE	HOOK AND LINE	Hook and Line
305	HOOK AND LINE, JIG	HOOK AND LINE	HOOK AND LINE	Hook and Line
306	HOOK AND LINE, TROLL	HOOK AND LINE	HOOK AND LINE	Hook and Line
307	HOOK AND LINE, CAST	HOOK AND LINE	HOOK AND LINE	Hook and Line
308	HOOK AND LINE, DRIFTING EEL	HOOK AND LINE	HOOK AND LINE	Hook and Line
309	HOOK AND LINE, FLY	HOOK AND LINE	HOOK AND LINE	Hook and Line
310	HOOK AND LINE, BOTTOM	HOOK AND LINE	HOOK AND LINE	Hook and Line
320	TROLL LINES	TROLL LINES	HOOK AND LINE	Hook and Line
321	TROLL LINE, MANUAL	TROLL LINES	HOOK AND LINE	Hook and Line
322	TROLL LINE, ELECTRIC	TROLL LINES	HOOK AND LINE	Hook and Line
323	TROLL LINE, HYDRAULIC	TROLL LINES	HOOK AND LINE	Hook and Line
324	TROLL LINE, GREEN-STICK	TROLL LINES	HOOK AND LINE	Hook and Line
330	HAND LINE	HAND LINE	HAND LINE	Hook and Line
331	TROLL & HAND LINE CMB	HAND LINE	HAND LINE	Hook and Line
340	AUTO JIG	HAND LINE	HAND LINE	Hook and Line
400	LONG LINES	LONG LINES	LONG LINES	Hook and Line
401	LONG LINES, VERTICAL	LONG LINES	LONG LINES	Hook and Line
402	LONG LINES, SURFACE	LONG LINES	LONG LINES	Hook and Line
403	LONG LINES, BOTTOM	LONG LINES	LONG LINES	Hook and Line
404	LONG LINES, SURFACE, MIDWATER	LONG LINES	LONG LINES	Hook and Line
405	LONG LINES, TROT	LONG LINES	LONG LINES	Hook and Line
406	LONG LINES, TURTLE HOOKS	LONG LINES	LONG LINES	Hook and Line
407	LONG LINES, DRIFT W/HOOKS	LONG LINES	LONG LINES	Hook and Line

Table 17. (cont.)

ACCSP Gear Code	ACCSP Gear Name	ACCSP Category Name	ACCSP Type Name	SEDAR Gear
408	BUOY GEAR	LONG LINES	LONG LINES	Hook and Line
409	LONG LINE, PELAGIC	LONG LINES	LONG LINES	Hook and Line
660	SPEARS	SPEARS	SPEARS AND GIGS	Hook and Line
661	SPEARS, DIVING	SPEARS	SPEARS AND GIGS	Hook and Line
662	GIGS	SPEARS	SPEARS AND GIGS	Hook and Line
700	HAND LINE	HAND LINE	HAND LINE	Hook and Line
701	TROLL AND HAND LINES CMB	HAND LINE	HAND LINE	Hook and Line
0	NOT CODED	NOT CODED	NOT CODED	OTHER
40	LAMPARA/RING NETS	LAMPARA/RING NETS	PURSE SEINES	OTHER
70	OTHER FIXED NETS	OTHER FIXED NETS	FIXED NETS	OTHER
71	WEIRS	OTHER FIXED NETS	FIXED NETS	OTHER
72	TRAP NETS	OTHER FIXED NETS	FIXED NETS	OTHER
73	FLOATING TRAPS (SHALLOW)	OTHER FIXED NETS	FIXED NETS	OTHER
74	BAG NETS	OTHER FIXED NETS	FIXED NETS	OTHER
75	CHANNEL NETS	OTHER FIXED NETS	FIXED NETS	OTHER
77	HOOP NET	OTHER FIXED NETS	FIXED NETS	OTHER
78	BANK TRAP, CHANNEL POUND	OTHER FIXED NETS	FIXED NETS	OTHER
182	BOX TRAPS	POTS & TRAPS, OTHER	POTS AND TRAPS	OTHER
183	WIRE BASKETS	POTS & TRAPS, OTHER	POTS AND TRAPS	OTHER
184	SLAT TRAPS (VIRGINIA)	POTS & TRAPS, OTHER	POTS AND TRAPS	OTHER
500	DREDGE	DREDGE	DREDGE	OTHER
501	DREDGE, HYDRAULIC, CLAM	DREDGE	DREDGE	OTHER
502	DREDGE, HYDRAULIC ESCALATOR, CLAM	DREDGE	DREDGE	OTHER
503	DREDGE, CLAM	DREDGE	DREDGE	OTHER
504	DREDGE, URCHIN	DREDGE	DREDGE	OTHER
505	DREDGE, SCALLOP	DREDGE	DREDGE	OTHER
506	DREDGE, SCALLOP, TURTLE DEFLECTOR	DREDGE	DREDGE	OTHER
507	DREDGE, SCALLOP, CHAIN MAT	DREDGE	DREDGE	OTHER
508	DREDGE, SCALLOP, CHAIN MAT, MODIFIED	DREDGE	DREDGE	OTHER
509	DREDGE, MUSSEL	DREDGE	DREDGE	OTHER
511	DREDGE, NEW BEDFORD	DREDGE	DREDGE	OTHER
512	DREDGE, DIGBY	DREDGE	DREDGE	OTHER
513	DREDGE, OYSTER	DREDGE	DREDGE	OTHER
550	DIP NETS	DIP NETS	DIP NETS AND CAST NETS	OTHER
551	CAST NETS	DIP NETS	DIP NETS AND CAST NETS	OTHER
552	BULLY NETS	DIP NETS	DIP NETS AND CAST NETS	OTHER
553	UMBRELLA/SCAP NETS	DIP NETS	DIP NETS AND CAST NETS	OTHER
600	TONGS	TONGS	RAKES, HOES, AND TONGS	OTHER
601	HAND TONGS	TONGS	RAKES, HOES, AND TONGS	OTHER
602	PATENT TONGS	TONGS	RAKES, HOES, AND TONGS	OTHER
620	RAKES	RAKES	RAKES, HOES, AND TONGS	OTHER
621	RAKES, BULL	RAKES	RAKES, HOES, AND TONGS	OTHER
622	RAKES, OYSTER	RAKES	RAKES, HOES, AND TONGS	OTHER
623	RAKES, HAND	RAKES	RAKES, HOES, AND TONGS	OTHER
630	HOES	HOES	RAKES, HOES, AND TONGS	OTHER
631	RAKES/SHOVELS/PITCHFORKS	RAKES/SHOVELS/PITCHFORKS	RAKES, HOES, AND TONGS	OTHER
632	PICKS	PICKS	RAKES, HOES, AND TONGS	OTHER
633	SCRAPES	SCRAPES	RAKES, HOES, AND TONGS	OTHER
650	HARPOONS	HARPOONS	SPEARS AND GIGS	OTHER
663	POWERHEADS	SPEARS	SPEARS AND GIGS	OTHER
670	HANDHELD HOOKS	HANDHELD HOOKS	SPEARS AND GIGS	OTHER
671	SPONGE HOOKS	HANDHELD HOOKS	SPEARS AND GIGS	OTHER
702	HAND LINES, AUTO JIG	HAND LINE	HAND LINE	OTHER
750	BY HAND, DIVING GEAR	BY HAND, DIVING GEAR	BY HAND	OTHER
760	BY HAND, NO DIVING GEAR	BY HAND, NO DIVING GEAR	BY HAND	OTHER
761	KNIFE, SEAWEED	BY HAND, NO DIVING GEAR	BY HAND	OTHER
762	WEEDWACKER, SEAWEED	BY HAND, NO DIVING GEAR	BY HAND	OTHER
800	OTHER GEARS	OTHER GEARS	OTHER GEARS	OTHER
801	UNSPECIFIED GEAR	OTHER GEARS	OTHER GEARS	OTHER
802	COMBINED GEARS	OTHER GEARS	OTHER GEARS	OTHER
803	AQUACULTURE	OTHER GEARS	OTHER GEARS	OTHER
804	CHEMICAL, OTHER	OTHER GEARS	OTHER GEARS	OTHER
805	BUSH NET	OTHER GEARS	OTHER GEARS	OTHER
806	BOW AND ARROW	OTHER GEARS	OTHER GEARS	OTHER
807	DRAG, ELECTRO	OTHER GEARS	OTHER GEARS	OTHER
808	OYSTER CAGE	OTHER GEARS	OTHER GEARS	OTHER
809	FISHING, ELECTRO	OTHER GEARS	OTHER GEARS	OTHER
810	SUCTION PUMP	SUCTION PUMPS	OTHER GEARS	OTHER
811	SUCTION PUMP, DIVING	SUCTION PUMPS	OTHER GEARS	OTHER
50	POUND NETS	POUND NETS	FIXED NETS	Pound Net
10	HAUL SEINES	HAUL SEINES	HAUL SEINES	Seine
21	STOP SEINE	OTHER SEINES	HAUL SEINES	Seine
22	COMMON SEINE	OTHER SEINES	HAUL SEINES	Seine
23	SWIPE NET	OTHER SEINES	HAUL SEINES	Seine
30	PURSE SEINE	PURSE SEINE	PURSE SEINES	Seine

Table 17. (cont.)

ACCSP Gear Code	ACCSP Gear Name	ACCSP Category Name	ACCSP Type Name	SEDAR Gear
31	PURSE SEINE, TARP	PURSE SEINE	PURSE SEINES	Seine
80	BEAM TRAWLS	BEAM TRAWLS	TRAWLS	Trawls
81	BEAM TRAWLS, FISH	BEAM TRAWLS	TRAWLS	Trawls
82	BEAM TRAWLS, OTHER - SHRIMP, CHOPSTICKS	BEAM TRAWLS	TRAWLS	Trawls
90	OTTER TRAWLS	OTTER TRAWLS	TRAWLS	Trawls
91	OTTER TRAWL BOTTOM, CRAB	OTTER TRAWLS, BOTTOM	TRAWLS	Trawls
92	OTTER TRAWL BOTTOM, FISH	OTTER TRAWLS, BOTTOM	TRAWLS	Trawls
93	OTTER TRAWL BOTTOM, LOBSTER	OTTER TRAWLS, BOTTOM	TRAWLS	Trawls
94	OTTER TRAWL BOTTOM, SCALLOP	OTTER TRAWLS, BOTTOM	TRAWLS	Trawls
95	OTTER TRAWL BOTTOM, SHRIMP	OTTER TRAWLS, BOTTOM	TRAWLS	Trawls
96	OTTER TRAWL BOTTOM, OTHER	OTTER TRAWLS, BOTTOM	TRAWLS	Trawls
97	OTTER TRAWL MIDWATER	OTTER TRAWLS, MIDWATER	TRAWLS	Trawls
98	OTTER TRAWL, HADDOCK SEPARATOR	OTTER TRAWLS, BOTTOM	TRAWLS	Trawls
99	OTTER TRAWL, RUHLE	OTTER TRAWLS, BOTTOM	TRAWLS	Trawls
100	OTTER TRAWL, TWIN	OTTER TRAWLS, BOTTOM	TRAWLS	Trawls
101	OTTER TRAWL, LARGE MESH BELLY PANEL	OTTER TRAWLS, BOTTOM	TRAWLS	Trawls
102	OTTER TRAWL BOTTOM, TWIN, SHRIMP	OTTER TRAWLS, BOTTOM	TRAWLS	Trawls
110	OTHER TRAWLS	OTHER TRAWLS	TRAWLS	Trawls
111	TRAWL, CLAM KICKING	OTHER TRAWLS	TRAWLS	Trawls
112	OTTER TRAWL MIDWATER, PAIRED	OTTER TRAWLS, MIDWATER	TRAWLS	Trawls
113	OTTER TRAWL BOTTOM, PAIRED	OTTER TRAWLS, BOTTOM	TRAWLS	Trawls
114	TRAWL, ROLLER	OTHER TRAWLS	TRAWLS	Trawls
115	TRAWL, ROLLER FRAME	OTHER TRAWLS	TRAWLS	Trawls
116	TRAWL, SKIMMER	OTHER TRAWLS	TRAWLS	Trawls
117	SCOTTISH SEINE	OTHER TRAWLS	TRAWLS	Trawls
118	BUTTERFLY NETS	OTHER TRAWLS	TRAWLS	Trawls
119	DANISH SEINE	OTHER TRAWLS	TRAWLS	Trawls
120	FLY NET	OTHER TRAWLS	TRAWLS	Trawls
121	OTTER TRAWL, PEELER	OTTER TRAWLS, BOTTOM	TRAWLS	Trawls

**Table 18. Commercial landings data collection methodology by state.**

	1950-1977	1978-1985	1986-1988	1989	1990-1993	1994	1995-2000	2001-2003	2004	2005	2006	2007-today
ME DMR												
NH FGD												
MA DMF												
RJ DFW												
CT DEEP												
NY DEC												
NJ DEP												
DE DFW												
MD DNR												
VMRC												
NC DMF												
SC DNR												
GA DNR												
FL FWC												
	Annual summaries		Monthly summaries		Mixed (trip reports and monthly summaries)		Trip reports (all fisheries)					



**Table 19. GLM estimated discards from the estuarine gill net fishery in North Carolina.**

Fishing Year	Observed Trips	Lengths collected	Dead discards	5% of releases	Total discards
1981	0	0	2,159	250	2,410
1982	0	0	1,802	209	2,010
1983	0	0	16,283	1,887	18,170
1984	0	0	9,954	1,154	11,108
1985	0	0	7,507	870	8,377
1986	0	0	8,215	952	9,167
1987	0	0	9,623	1,115	10,738
1988	0	0	10,418	1,207	11,625
1989	0	0	10,218	1,184	11,403
1990	0	0	7,414	859	8,273
1991	0	0	12,652	1,466	14,118
1992	0	0	18,443	2,137	20,581
1993	0	0	12,611	1,462	14,073
1994	0	0	4,682	543	5,224
1995	0	0	15,870	1,839	17,709
1996	0	0	3,093	358	3,451
1997	0	0	12,932	1,499	14,431
1998	0	0	28,981	3,359	32,339
1999	0	0	33,728	3,909	37,637
2000	0	0	11,310	1,311	12,621
2001	0	0	4,013	465	4,478
2002	0	0	8,411	975	9,385
2003	0	0	5,344	619	5,964
2004	535	839	14,302	1,792	16,094
2005	457	762	14,806	1,264	16,070
2006	184	353	14,846	1,423	16,268
2007	250	275	10,490	967	11,457
2008	194	345	17,007	1,302	18,308
2009	280	279	9,188	786	9,974
2010	394	114	1,530	356	1,887
2011	660	266	3,362	327	3,689
2012	626	1,838	33,703	5,245	38,948
2013	739	1,112	15,180	2,616	17,796
2014	926	944	13,612	1,633	15,245
2015	699	420	6,369	812	7,181
2016	721	977	16,266	1,620	17,886
2017	497	526	7,355	1,486	8,841
2018	351	130	3,164	367	3,531
2019	97	136	7,088	1,169	8,257
2020					
2021	7	8	2,626	368	2,994
2022	32	71	20,854	1,007	21,861

**Table 20. North Carolina red drum lengths obtained by year and gear from commercial fishery-dependent fish house sampling.**

Fishing Year	Beach Seine	Gill Net	Haul Seine	Hook & Line	Ocean Trawl	Pound Net	Total
1989	0	0	23	7	0	0	30
1990	0	373	28	0	2	78	481
1991	18	228	12	0	1	34	293
1992	4	372	91	9	4	60	540
1993	9	230	56	0	2	26	323
1994	0	147	47	0	1	8	203
1995	0	177	83	0	23	73	356
1996	0	211	8	0	1	6	226
1997	7	535	202	0	0	10	754
1998	14	586	12	0	0	6	618
1999	84	776	25	0	4	51	940
2000	2	428	4	0	17	16	467
2001	2	324	26	0	0	30	382
2002	7	356	26	0	0	37	426
2003	48	346	6	0	0	2	402
2004	10	493	1	0	0	9	513
2005	8	945	19	0	0	72	1,044
2006	41	1,075	28	0	7	59	1,210
2007	10	1,491	1	0	4	147	1,653
2008	35	923	39	0	0	72	1,069
2009	0	900	18	0	0	45	963
2010	12	842	4	0	0	75	933
2011	6	423	2	0	0	44	475
2012	18	897	16	0	0	36	967
2013	14	760	7	0	0	159	940
2014	5	606	9	0	0	19	639
2015	3	565	0	0	0	21	589
2016	7	564	2	0	0	18	591
2017	0	632	1	0	0	22	655
2018	0	316	3	0	0	55	374
2019	3	247	3	0	0	17	270
2020	9	638	5	0	0	65	717
2021	8	747	13	0	0	59	827
2022	0	464	28	0	0	12	504
<b>Total</b>	<b>384</b>	<b>18,617</b>	<b>848</b>	<b>16</b>	<b>66</b>	<b>1,443</b>	<b>21,374</b>

**Table 21. Number of commercial red drum harvested by gear and year from 1989 to 2022 in North Carolina.**

Fishing Year	Beach Seine	Gill Net	Haul Seine	Hook & Line	Ocean Trawl	Other	Pound Net	Total
*1989	258	2,484	697	65	56	245	715	4,520
1990	10529	53,197	7875	104	194	5186	3,239	80,324
1991	1585	32,812	1243	225	17	1990	1,226	39,098
1992	553	31,082	2274	97	844	240	2,024	37,114
1993	1481	32,833	2750	661	69	276	1,392	39,462
1994	447	17,794	4488	452	60	185	1,376	24,802
1995	1705	38,729	7382	567	157	85	3,196	51,821
1996	146	9,311	1108	382	28	34	880	11,889
1997	2667	61,396	13621	1073	0	34	495	79,286
1998	918	63,458	837	799	80	38	546	66,676
1999	3330	77,811	664	597	119	96	1,681	84,298
2000	806	31,774	85	245	75	15	878	33,878
2001	34	13,771	118	76	14		932	14,945
2002	217	22,499	355	50	4	42	1,270	24,437
2003	215	11,839	227	31	9	7	457	12,785
2004	141	17,327	60	63	0	39	466	18,096
2005	347	31,813	299	69	2	53	1,537	34,120
2006	472	33,004	638	56	10	156	1,273	35,609
2007	111	66,013	126	26	38	24	1,495	67,833
2008	145	28,102	775	19	0	30	1,084	30,155
2009	105	54,498	390	48	0	35	1,417	56,493
2010	44	24,205	313	33	0	19	1,132	25,746
2011	40	16,422	54	51	0	22	1,069	17,658
2012	46	42,535	330	113	0	91	1,406	44,521
2013	83	50,627	206	98	0	51	6,823	57,888
2014	40	23,346	133	78	0	63	1,584	25,244
2015	16	12,561	27	33	0	36	845	13,518
2016	10	23,996	66	73	0	77	1,183	25,405
2017	19	34,652	154	89	0	93	4,461	39,468
2018	41	18,757	10	64	0	17	1,702	20,591
2019	62	12,335	589	21	0	5	1,139	14,151
2020	102	39,281	786	54	0	69	5,302	45,594
2021	126	40,725	229	48	0	116	2,913	44,157
2022	6	35,806	154	97	0	32	3,303	39,398

**Table 22. Recreational commercial gill net landings from North Carolina from 1989 to 2022.**

Fishing Year	RCGL Harvest in weight (lb)	RCGL harvest in numbers
1989	9,097	6,094
1990	6,098	3,472
1991	6,144	2,142
1992	10,531	2,029
1993	12,495	2,143
1994	5,067	1,161
1995	12,839	2,528
1996	2,992	608
1997	12,352	4,008
1998	16,347	4,142
1999	24,750	5,079
2000	10,190	2,074
2001	3,633	899
2002	6,327	1,469
2003	4,255	773
2004	3,863	1,131
2005	9,552	2,077
2006	10,316	2,154
2007	20,705	4,309
2008	8,044	1,834
2009	17,321	3,557
2010	7,629	1,580
2011	5,707	1,072
2012	8,380	2,776
2013	14,899	3,305
2014	8,426	1,524
2015	3,853	820
2016	6,774	1,566
2017	11,343	2,262
2018	6,177	1,224
2019	3,072	805
2020	11,538	2,564
2021	13,009	2,658
2022	11,180	2,337

**Table 23. Florida red drum landings during the 1980s in numbers of fish (Murphy 2009).**

Year	Landings
1981	87,276
1982	33,931
1983	37,248
1984	38,431
1985	26,050
1986	22,609
1987	12,793
1988	73









### Pound Net

Fishing Year	24	26	30	32	34	36	38	40	42	44	46	48	50	52	54	56	58	60	62	64	66	68	70	72	74	76	78	80+
1989				264			39			29	29	49	49	29						29	10	10		10	10	10		147
1990					77	127	338	336	322	425	478	413							26	123	26			26	29			495
1991							72			108	397	144	144	36						108				72	36			108
1992									60	95							35	369	162	526	345	166	230					36
1993														77	78	102	174	532	249	40	26	45	70					
1994						2		7	7	2	26	50	83	156	234	116	81	114	163	14	109	85	28	24	52			17
1995										64	506	61	49	31	31	184	233	306	361	487	662	61	61		31		34	34
1996	1	2							8	24	85	185	160	106	46	5	2	3	17	55	76	69	24	12				
1997			0	0	0	0	0	0	0	17	125	141	104	67	25	10	4	0	0	0	0							0
1998					1	1				13	47	51	54	42	51	60	83	63	33	19	13	4	3	4	4			
1999										28	28				70	98	204	366	481	266	70	28		42				
2000										7	25	22	22	27	74	91	139	132	129	100	56	31	11	5	5			2
2001											31	31			31	93	124	62	186	124	155	62	31					
2002				27							202	270	115	27		27			162	108	196	54	81					
2003										9	24	30	13	8	8	34	52	62	67	58	40	24	19	7	1	1		
2004									3	33	112	73	47	29	53	44	23	17	12	9	5	3		3	1			
2005											20			20		60	60	227	243	387	310	143	47		20			
2006															33	33	328	148	300	317	66	16	33					
2007										18	21	37	63	130	159	317	252	170	152	80	27	17	18			18	9	9
2008											15	34	15	15	63	58	160	145	116	87	102	116	87	73				
2009															109	244	410	192	272	27	108				54			
2010											44	15						196	207	205	145	161	102	44		15		
2011										24	24	73				73	49	146	170	243	121	49	49					49
2012							38			76	570	361	152	57				38	76				38					
2013											299	32	326	379	581	867	1150	1146	993	558	193	235	32	32				
2014										2	24	32	32	44	68	99	228	233	228	211	180	124	61	12	7			
2015										40	40	121	40		40			40	121	161		80	80	80				
2016									7	51	204	172	79	84	52	37	54	80	99	109	66	51	32	4	2			
2017															811	1217		608	608	811	406							
2018			171							24		24		24		171	24	193	419	289	217	96	24			24		
2019						4		4	4	56	238	206	115	95	48	36	40	44	52	71	60	44	12	12				
2020														136	409	1295	799	1814	526	205	117							
2021												296	197	148	49	543	296	296	247	99	99	296	99	197				49
2022										25	105	105	166	320	413	345	370	296	339	351	191	148	74	37	6		6	6

**Table 25. Recreational red drum catch estimates (1,000s of fish) for the northern stock from MRIP. \*\*2022 data are preliminary.**

Fishing Year	Harvest		Released Alive	
	Estimate	PSE	Estimate	PSE
1981	63.35	0.31	10.50	0.97
1982	84.71	0.41	0.00	0.00
1983	98.16	0.37	8.87	0.87
1984	416.97	0.23	3.33	0.84
1985	110.27	0.29	5.46	1.00
1986	370.20	0.43	30.29	0.50
1987	268.63	0.30	39.11	0.41
1988	521.69	0.53	119.99	0.54
1989	272.24	0.38	41.54	0.54
1990	92.22	0.24	87.14	0.33
1991	166.07	0.21	399.82	0.20
1992	73.27	0.21	475.70	0.64
1993	137.65	0.18	499.05	0.37
1994	73.48	0.27	247.62	0.16
1995	153.12	0.13	371.40	0.16
1996	69.07	0.31	149.32	0.20
1997	96.11	0.18	758.89	0.17
1998	186.99	0.15	880.09	0.27
1999	210.25	0.13	1,241.29	0.15
2000	122.81	0.21	433.36	0.18
2001	92.83	0.20	981.16	0.17
2002	252.16	0.20	3,409.15	0.17
2003	91.99	0.21	254.99	0.16
2004	62.61	0.25	439.95	0.13
2005	160.02	0.17	1,432.80	0.26
2006	220.27	0.21	1,300.79	0.17
2007	236.27	0.13	1,456.30	0.13
2008	245.91	0.18	2,523.55	0.15
2009	309.10	0.14	1,571.62	0.11
2010	187.48	0.15	1,307.85	0.11
2011	274.98	0.31	5,791.62	0.21
2012	491.19	0.19	10,570.66	0.14
2013	907.53	0.17	2,597.72	0.30
2014	228.67	0.17	1,541.42	0.29
2015	142.49	0.26	1,170.22	0.14
2016	590.71	0.34	4,771.46	0.28
2017	469.11	0.19	3,203.34	0.25
2018	213.99	0.32	1,559.18	0.27
2019	475.91	0.19	4,897.81	0.14
2020	767.84	0.18	3,587.11	0.16
2021	539.14	0.12	3,587.29	0.17
2022	321.61	0.14	2,209.79	0.14

**Table 26. Recreational red drum catch estimates (1,000s of fish) for the southern stock from MRIP. \*\*2022 data are preliminary.**

Fishing Year	South Carolina				Georgia				Florida			
	Harvest		Released Alive		Harvest		Released Alive		Harvest		Released Alive	
	Estimate	PSE	Estimate	PSE	Estimate	PSE	Estimate	PSE	Estimate	PSE	Estimate	PSE
1981	190.75	0.40	8.25	0.68	175.46	0.64	0.41	0.99	415.78	0.32	35.51	0.75
1982	278.77	0.34	114.84	0.08	65.17	0.29	8.75	0.61	804.34	0.42	105.74	0.54
1983	479.35	0.67	11.37	0.69	370.35	0.25	3.97	0.56	1,861.60	0.26	199.21	0.38
1984	326.28	0.39	60.67	0.68	466.78	0.22	15.59	0.43	1,642.06	0.28	147.84	0.48
1985	938.70	0.18	106.12	0.39	288.08	0.14	47.47	0.24	341.38	0.25	458.85	0.38
1986	310.74	0.23	71.75	0.29	123.33	0.19	194.53	0.19	121.35	0.33	248.59	0.26
1987	725.71	0.18	189.47	0.28	154.67	0.14	205.13	0.18	106.76	0.47	812.23	0.33
1988	388.19	0.27	131.64	0.28	155.87	0.22	173.38	0.25	20.02	0.51	337.67	0.25
1989	291.27	0.21	129.30	0.34	117.20	0.30	145.30	0.47	202.89	0.30	564.41	0.32
1990	404.94	0.31	139.61	0.43	175.24	0.25	202.83	0.26	87.71	0.33	967.57	0.41
1991	311.48	0.27	171.29	0.49	249.21	0.35	108.57	0.20	396.89	0.25	1,277.10	0.35
1992	285.42	0.22	131.02	0.29	151.19	0.18	227.04	0.30	195.05	0.16	1,532.44	0.16
1993	276.73	0.28	351.18	0.34	242.05	0.18	231.39	0.33	274.91	0.14	1,816.68	0.16
1994	97.46	0.30	639.92	0.21	165.63	0.23	446.40	0.28	354.81	0.18	2,256.37	0.17
1995	364.87	0.50	640.25	0.25	250.16	0.24	172.03	0.27	377.35	0.19	1,868.68	0.11
1996	349.94	0.27	844.34	0.43	115.46	0.27	108.41	0.32	352.47	0.19	1,026.13	0.17
1997	240.98	0.19	202.74	0.21	67.99	0.26	60.81	0.24	296.12	0.21	1,503.06	0.14
1998	194.23	0.17	305.07	0.18	84.33	0.32	75.74	0.37	428.95	0.17	2,060.40	0.11
1999	132.68	0.27	306.50	0.23	148.72	0.23	129.19	0.27	520.41	0.13	2,083.98	0.11
2000	88.54	0.24	205.13	0.23	189.89	0.24	320.23	0.22	652.69	0.13	2,579.70	0.14
2001	167.80	0.19	466.82	0.20	225.39	0.16	369.33	0.19	460.53	0.11	2,329.61	0.13
2002	194.04	0.20	607.53	0.20	259.79	0.19	455.45	0.17	561.08	0.16	2,755.51	0.17
2003	266.12	0.25	856.59	0.19	222.77	0.16	424.50	0.19	530.95	0.14	3,524.28	0.16
2004	176.80	0.19	721.04	0.20	215.28	0.17	300.69	0.23	548.77	0.14	4,145.14	0.12
2005	255.95	0.25	953.10	0.14	244.79	0.18	419.11	0.21	593.20	0.15	4,539.49	0.18
2006	138.47	0.27	1,181.79	0.17	126.13	0.26	334.19	0.18	509.67	0.13	2,193.53	0.12
2007	169.65	0.26	785.02	0.18	280.14	0.22	451.54	0.25	379.98	0.13	2,278.91	0.13

Fishing Year	South Carolina				Georgia				Florida			
	Harvest		Released Alive		Harvest		Released Alive		Harvest		Released Alive	
	Estimate	PSE	Estimate	PSE	Estimate	PSE	Estimate	PSE	Estimate	PSE	Estimate	PSE
2008	222.17	0.29	1,476.92	0.18	208.30	0.18	401.59	0.25	427.50	0.17	2,379.63	0.16
2009	303.12	0.18	1,541.42	0.15	181.42	0.22	574.45	0.17	640.95	0.14	3,530.62	0.12
2010	495.53	0.16	2,303.04	0.15	470.44	0.19	733.53	0.16	717.92	0.12	7,094.37	0.13
2011	216.04	0.21	1,314.78	0.13	139.93	0.22	352.74	0.23	841.64	0.17	2,878.45	0.11
2012	388.88	0.27	1,553.51	0.12	146.80	0.24	275.37	0.31	758.62	0.14	2,783.19	0.11
2013	214.36	0.15	1,394.64	0.09	232.47	0.18	578.76	0.20	1,075.91	0.12	6,084.90	0.14
2014	385.28	0.28	1,875.95	0.17	207.98	0.19	1,171.41	0.23	1,123.90	0.15	4,210.56	0.11
2015	266.71	0.31	1,537.67	0.23	220.23	0.21	538.01	0.22	839.80	0.14	4,452.51	0.12
2016	382.33	0.16	1,531.86	0.15	292.93	0.24	986.02	0.18	1,293.51	0.17	4,786.23	0.18
2017	359.50	0.19	2,047.33	0.17	517.97	0.22	974.70	0.18	926.94	0.21	5,711.24	0.16
2018	273.90	0.15	1,750.99	0.13	553.11	0.20	1,101.35	0.19	1,179.24	0.12	4,397.08	0.12
2019	309.62	0.25	2,816.14	0.21	283.06	0.24	864.34	0.36	515.84	0.18	3,287.01	0.16
2020	203.18	0.20	1,849.16	0.14	189.60	0.18	606.35	0.15	531.40	0.22	3,271.16	0.14
2021	231.87	0.15	1,496.35	0.16	393.52	0.21	1,061.19	0.21	688.97	0.34	5,191.63	0.32
2022	219.14	0.15	1,374.21	0.11	612.68	0.15	1,963.25	0.16	359.71	0.23	4,016.83	0.14

**Table 27. Fishery-dependent biological samples collected via the SCDNR freezer, tournament, and state finfish surveys.**

<b>Description</b>	<b>Tournament Program</b>	<b>Freezer Program</b>	<b>State Finfish Survey</b>	<b>Fishery-Dependent Samples</b>
<b>Years</b>	<b>1986-2022</b>	<b>1995-2022</b>	<b>1988-2022</b>	<b>1986-2022</b>
<b>Red Drum Investigated</b>	<b>1,023</b>	<b>2,283</b>	<b>11,487</b>	<b>14,793</b>
<b>Total Length (mm)</b>	<b>1,021</b>	<b>2,275</b>	<b>2,814</b>	<b>6,110</b>
<b>Midline Length (mm)</b>	<b>1,049</b>	<b>2,485</b>	<b>8,673</b>	<b>12,207</b>
<b>Standard Length (mm)</b>	<b>1,019</b>	<b>2,236</b>		<b>3,255</b>
<b>Weight (g)</b>	<b>986</b>	<b>5</b>		<b>991</b>
<b>Age (Yrs)</b>	<b>1,007</b>	<b>2,229</b>		<b>3,236</b>
Length	161	859		1,020
Scale	17	1		18
Otoliths	829	1,369		2,198
<b>Sex</b>	<b>1,017</b>	<b>2,282</b>		<b>3,299</b>
Macroscopic	971	2,278		3,249
Histology	46	4		50
<b>Maturity Status/Stage</b>	<b>969</b>	<b>2,200</b>		<b>3,169</b>
Macroscopic	923	2,196		3,119
Histology	46	4		50

Note: Data was not updated to reflect collections made in the first half of 2023, which was included in the fishing year definition but not available during data workshop.

**Table 28. MGFTP guidance to anglers for tagging red drum throughout coastal South Carolina.**

<b>Years</b>	<b>Guidance</b>
1978-1992	Any size red drum
1993-2010	≥18 inches (457.2 mm) TL
2011-2019	Fish <27 inches (658.8 mm) TL - T-bar tag Fish ≥27 inches (658.8 mm) TL - Nylon Dart Tag
2020-2022	Previous tag types + only fish ≥10 inches (254 mm) TL Tag one red drum per "school" per day

**Table 29. Number of recaptures as a function of years-at-large from the SCDNR conventional tagging program.**

<b>Years-at-Large</b>	<b>Recaptures</b>
0-1	31,457
1-2	8,315
2-3	2,216
3-4	510
5-6	179
6-7	84
7-8	31
8-9	44
9-10	32
10-11	27
11-12	23
12-13	15
13-14	9
14-15	8
15-16	5
16-17	7
17-18	5
18-19	7
19-20	3
20-21	1
21-22	4
22-23	0
23-24	1
24-25	0

**Table 30. Indices of abundance for the northern red drum stock. Indices are scaled to their means and SEs are in terms of log(Index).**

Fishing Year	NC_BagSeine		NC_GillNet		NC_Longline	
	Index	SE	Index	SE	Index	SE
1991	2.753	0.219				
1992	0.750	0.230				
1993	3.951	0.226				
1994	1.138	0.231				
1995	0.652	0.215				
1996						
1997	1.840	0.198				
1998	1.620	0.214				
1999	0.342	0.236				
2000	0.651	0.223				
2001	0.268	0.242				
2002	0.408	0.225				
2003	0.742	0.207	0.388	0.173		
2004	1.473	0.213	1.422	0.153		
2005	1.631	0.214	1.537	0.153		
2006	0.569	0.219	0.863	0.144		
2007	0.660	0.205	0.501	0.181	0.708	0.219
2008	0.211	0.228	1.123	0.178	0.297	0.235
2009	0.247	0.230	1.079	0.170	0.667	0.205
2010	0.718	0.216	1.207	0.150	0.747	0.212
2011	1.413	0.219	0.171	0.197	0.468	0.205
2012	0.410	0.228	2.808	0.155	1.138	0.208
2013	0.215	0.241	1.338	0.152	1.150	0.209
2014	0.265	0.233	0.844	0.148	2.254	0.267
2015	0.844	0.218	0.736	0.148	1.218	0.227
2016	1.141	0.211	0.971	0.150	1.022	0.252
2017	0.578	0.214	0.585	0.148	1.132	0.220
2018	2.765	0.223	0.346	0.154	2.495	0.279
2019	0.900	0.208	1.442	0.154	0.605	0.246
2020	0.669	0.212				
2021	0.968	0.214	1.014	0.165	0.928	0.233
2022	0.211	0.227	0.625	0.194	0.170	0.239

**Table 31. Indices of abundance for the southern red drum stock. Indices are scaled to their means and SEs are in terms of log(Index).**

Fishing Year	SC_Rotenone		SC_StopNet		SC_Trammel		SC_Electro		SC_Longline_historic		SC_Longline_contemporary		GA_GillNet		GA_Longline		FL_21.3_HaulSeine		FL_183_HaulSeine		
	Index	SE	Index	SE	Index	SE	Index	SE	Index	SE	Index	SE	Index	SE	Index	SE	Index	SE	Index	SE	
1986	2.208	0.407																			
1987	1.273	0.431	1.076	0.274																	
1988	0.368	0.585	0.991	0.281																	
1989	0.642	0.434	0.864	0.255																	
1990	1.781	0.456	0.944	0.24																	
1991	0.703	0.468	1.208	0.245	2.443	0.174															
1992	0.219	0.595	1.023	0.244	1.79	0.136															
1993	0.807	0.53	0.893	0.26	1.728	0.112															
1994					1.033	0.1			1.111	0.205											
1995					1.483	0.096			1.327	0.182											
1996					0.906	0.095			1.189	0.159											
1997					0.83	0.09			0.493	0.185											
1998					0.654	0.089			0.795	0.165											
1999					0.501	0.093			1.223	0.165											
2000					1.044	0.092			0.679	0.172											
2001					1.264	0.089	0.997	0.101	1.008	0.161							0.754	0.365	1.468	0.229	
2002					1.41	0.088	1.492	0.096	1.17	0.172			1.62	0.224			1.608	0.346	1.077	0.228	
2003					1.638	0.085	1.326	0.089	1.336	0.164			0.803	0.199			1.678	0.367	2.096	0.21	
2004					1.482	0.086	0.773	0.092	0.905	0.173			1.675	0.181			0.673	0.396	1.371	0.216	
2005					1.307	0.087	0.811	0.091	1.119	0.321			0.421	0.181			0.119	0.761	1.625	0.224	
2006					0.684	0.09	0.66	0.093	0.644	0.235			0.807	0.226	0.295	0.361	1.255	0.293	0.762	0.258	
2007					0.85	0.089	0.916	0.101			1.083	0.279	1.362	0.222	0.343	0.375	1.652	0.281	1.005	0.234	
2008					0.938	0.09	1.22	0.088			1.262	0.272	0.782	0.22	0.33	0.307	1.376	0.273	0.79	0.243	
2009					1.283	0.087	1.314	0.088			2.454	0.266	1.537	0.193	0.935	0.335	1.337	0.277	1.686	0.216	
2010					1.054	0.086	1.088	0.096			0.625	0.164	0.584	0.213	0.422	0.355	0.347	0.446	1.367	0.228	
2011					0.72	0.087	1.094	0.089			0.543	0.171	0.355	0.238	0.842	0.421	0.902	0.306	1.034	0.232	
2012					0.624	0.091	1.492	0.089			1.079	0.173	0.581	0.198	0.246	0.29	3.648	0.243	0.907	0.247	
2013					0.782	0.09	0.958	0.09			0.93	0.173	0.745	0.211	1.019	0.314	0.432	0.385	0.548	0.291	
2014					0.624	0.094	0.901	0.094			0.883	0.181	0.539	0.279	1.606	0.235	0.316	0.458	0.659	0.256	
2015					0.587	0.091	0.824	0.094			0.95	0.183	1.16	0.207	0.635	0.27	0.252	0.56	0.624	0.259	
2016					0.479	0.095	1.198	0.094			1.187	0.179	1.372	0.179	4.133	0.273	0.655	0.361	0.639	0.299	
2017					0.649	0.094	0.963	0.087			0.751	0.189	1.33	0.203	1.808	0.227	0.311	0.435	0.474	0.303	
2018					0.58	0.093	0.921	0.092			1.094	0.191	0.871	0.178	0.921	0.296	0.081	2.716	0.793	0.242	
2019					0.386	0.11	0.546	0.114			1.113	0.183	0.333	0.243	0.892	0.417	0.856	0.313	0.443	0.343	
2020					0.758	0.104	0.445	0.112			0.862	0.181	1.093	0.163			0.474	0.422	0.586	0.287	
2021					0.615	0.106	0.527	0.117			0.639	0.187	1.123	0.2	0.853	0.24	2.275	0.252	1.044	0.227	
2022					0.877	0.098	1.533	0.099			0.543	0.197	1.908	0.207	0.721	0.232					



**Table 32. Fixed stations sampled by year as part of the SCDNR rotenone survey. Collections sites are arranged via estuary, from the South to the North.**

Estuary	St. Helena Sound / ACE Basin		North Edisto & Stono		Charleston Harbor								Isle of Palms Sounds	
River	Coosaw River		South Edisto	North Edisto	Stono	Ashley	Wando						Inlet Creek	
Year	Brickyard Creek	Triple Creek	South Edisto	Tom Post Creek	Stono River	Orange Grove Creek	Beresford Creek	Deep Creek	Foster Creek	Horlbeck Creek	Lachicotte Creek	Pita Creek	Wards Bridge	Inlet Creek
1986														
1987	1	7	5	1	5	1	7				7	7		7
1988		7	7		7		8				8	12		8
1989							1	7	10		10	9	1	
1990								12	12		12	12		
1991								13	12		12	12		
1992								6	6	1	6	6		
1993								4	4		4	4		
1994								4	4		4	4		
<b>Total</b>	<b>1</b>	<b>14</b>	<b>12</b>	<b>1</b>	<b>12</b>	<b>1</b>	<b>16</b>	<b>46</b>	<b>48</b>	<b>1</b>	<b>63</b>	<b>73</b>	<b>1</b>	<b>15</b>

**Table 33. Summary of life history information collected via the SCDNR during fishery-independent and fishery-dependent sampling program efforts. Bold #s represent years or sample sizes. Only sample sizes, by sex and maturity status where indicated, are provided for sex and maturity status. All lengths in mm, all weights in g, and all ages in yrs. Age-Length = ages determined based on length at capture and capture month; Age-Otolith = ages determined by otolith thin section aging techniques.**

Variable	Fishery-Independent Data						Fishery-Dependent Data				Total
	Rotenone	Stop Net	Trammel Net	Electrofishing	Longline - Historic	Longline - Contemporary	Misc.	Tournament	Freezer	SFS	
<b>Years</b>	<b>1986-1994</b>	<b>1985-1998</b>	<b>1987-2023</b>	<b>2001-2023</b>	<b>1994-2009</b>	<b>2007-2022</b>	<b>1994-1997</b>	<b>1986-2022</b>	<b>1995-2022</b>	<b>1988-2022</b>	<b>1985-2023</b>
<b>Fishing Years</b>	<b>1985-1993</b>	<b>1984-1987</b>	<b>1986-2023</b>	<b>2000-2023</b>	<b>1994-2009</b>	<b>2007-2022</b>	<b>1994-1997</b>	<b>1986-2022</b>	<b>1995-2022</b>	<b>1987-2021</b>	<b>1984-2023</b>
<b>Red Drum</b>	<b>1,679</b>	<b>8,121</b>	<b>85,858</b>	<b>15,664</b>	<b>3,709</b>	<b>8,659</b>	<b>4,643</b>	<b>1,023</b>	<b>2,283</b>	<b>11,487</b>	<b>143,126</b>
<b>Total Length</b>	<b>1,588</b>	<b>8,107</b>	<b>85,536</b>	<b>15,659</b>	<b>3,689</b>	<b>8,593</b>	<b>4,632</b>	<b>1,021</b>	<b>2,275</b>	<b>2,814</b>	<b>133,914</b>
Range	5-489	33-910	152-1,130	19-952	507-1,246	571-1,223	158-977	277-1,150	343-810	294-680	5-1,223
$\bar{X} \pm SE$	49 ± 1.4	432 ± 1.8	535 ± 0.6	416 ± 1.0	971 ± 1.3	954 ± 0.9	526 ± 2.2	551 ± 4.5	484 ± 1.7	458 ± 1.1	-
<b>Midline Length</b>	-	<b>24</b>	<b>3,390</b>	<b>18</b>	<b>3,687</b>	<b>8,494</b>	-	<b>26</b>	<b>202</b>	<b>8,673</b>	<b>24,514</b>
Range	-	339-730	215-982	270-746	491-1,154	534-1,145	-	358-642	348-670	220-1,361	220-1,361
$\bar{X} \pm SE$	-	444 ± 23.0	543 ± 2.5	488 ± 31.3	908 ± 1.2	891 ± 0.8	-	458 ± 16.5	452 ± 5.6	457 ± 0.9	-
<b>Standard Length</b>	<b>1,679</b>	<b>1,023</b>	<b>33,519</b>	<b>11,119</b>	<b>106</b>	<b>8,659</b>	<b>230</b>	<b>1,109</b>	<b>2,236</b>	-	<b>59,680</b>
Range	4-398	26-673	123-955	15-790	655-989	577-1,005	127-713	225-920	283-669	-	4-1,005
$\bar{X} \pm SE$	38 ± 1.1	241 ± 3.1	385 ± 0.8	323 ± 1.1	749 ± 4.6	793 ± 0.8	361 ± 6.2	452 ± 5.7	396 ± 3.4	-	-
<b>Weight (g)</b>	<b>722</b>	<b>806</b>	<b>3,554</b>	<b>818</b>	<b>105</b>	<b>8,659</b>	<b>160</b>	<b>986</b>	<b>5</b>	-	<b>15,815</b>
Range	1-1,261	1-5,950	95-8,850	1-7,000	5,000-17,070	1,110-26,500	259-7,500	279-14,629	862-4,042	-	1-26,500
$\bar{X} \pm SE$	22 ± 2.27	507 ± 28.2	1,513 ± 23.1	1,086 ± 32.4	7,687 ± 168.6	8,212 ± 23.0	1,105 ± 79.31	2,094 ± 43.33	1,931 ± 28.5	-	-
<b>Age-Length</b>	<b>1,581</b>	<b>5,251</b>	<b>34,912</b>	<b>11,374</b>	-	-	<b>2,098</b>	<b>161</b>	<b>859</b>	-	<b>56,236</b>
Range	0.00-1.00	0.2-2.17	0.75-2.67	0.08-2.75	-	-	0.75-2.17	1.08-2.00	1.00-2.25	-	0.00-2.75
X-bar +/-SE	0.29 ± 0.01	1.21 ± 0.00	1.30 ± 0.00	1.36 ± 0.00	-	-	1.35 ± 0.01	1.45 ± 0.03	1.47 ± 0.01	-	-
<b>Age-Otolith</b>	<b>6</b>	<b>154</b>	<b>2,055</b>	<b>224</b>	<b>106</b>	<b>1,361</b>	<b>51</b>	<b>829</b>	<b>1,369</b>	-	<b>6,155</b>
Range	0.92-1.92	1.08-3.83	0.75-22.17	0.83-5.08	3.17-32.67	3.00-40.25	1.58-3.83	0.92-41.08	0.92-5.08	-	0.83-41.08
$\bar{X} \pm SE$	1.08 ± 0.17	2.16 ± 0.05	2.49 ± 1.07	2.25 ± 0.05	8.92 ± 5.50	15.84 ± 0.22	2.55 ± 0.09	2.77 ± 0.12	2.12 ± 0.01	-	-
<b>Sex</b>	-	-	<b>674</b>	<b>193</b>	<b>16</b>	<b>1,171</b>	-	<b>46</b>	<b>4</b>	-	<b>2,104</b>
Female	-	-	320	105	9	673	-	25	3	-	1,135
Male	-	-	337	84	7	495	-	20	1	-	944
Unknown	-	-	17	4	-	3	-	1	-	-	25
<b>Maturity Status</b>	-	-	<b>674</b>	<b>189</b>	<b>16</b>	<b>1,168</b>	-	<b>45</b>	<b>4</b>	-	<b>2,096</b>
Female	-	-	320	105	9	673	-	25	3	-	1,135
Immature	-	-	275	100	1	45	-	24	3	-	448
Mature	-	-	44	74	8	626	-	1	-	-	753
Unknown	-	-	1	-	-	2	-	-	-	-	3
Male	-	-	337	84	7	495	-	20	1	-	944
Immature	-	-	219	74	-	12	-	13	1	-	319
Mature	-	-	116	10	7	483	-	7	-	-	623
Unknown	-	-	2	-	-	-	-	-	-	-	2

\* - Histology only derived sex and maturity information

**Table 34. Size distribution by month of red drum encountered by the SCDNR rotenone survey. The year is aligned to start with August, the first month in which newly born red drum recruit to the gear in South Carolina. Green shaded cells represent age-0 red drum monthly throughout the year. Note, very few age-1+ red drum (denoted by pink shaded cells) are encountered by this survey, with those individuals only captured during the months of August and July.**

TL (mm)	Month												Total
	Aug.	Sept.	Oct.	Nov.	Dec.	Jan.	Feb.	Mar.	Apr.	May	Jun.	Jul.	
475	0	0	0	0	0	0	0	0	0	0	0	1	1
450	0	0	0	0	0	0	0	0	0	0	0	0	0
425	0	0	0	0	0	0	0	0	0	0	0	0	0
400	0	0	0	0	0	0	0	0	0	0	0	0	0
375	0	0	0	0	0	0	0	0	0	0	0	0	0
350	0	0	0	0	0	0	0	0	0	0	0	0	0
325	0	0	0	0	0	0	0	0	0	0	0	1	1
300	2	0	0	0	0	0	0	0	0	0	0	0	2
275	2	0	0	0	0	0	0	0	0	0	0	2	4
250	0	0	0	0	0	0	0	0	0	0	1	2	3
225	0	0	0	0	0	0	0	0	0	0	0	6	6
200	0	0	0	0	0	0	0	0	0	0	11	2	13
175	0	0	0	0	0	0	0	0	0	10	41	1	52
150	0	0	0	0	0	0	0	0	3	14	50	0	67
125	0	0	0	0	0	0	0	0	17	34	9	0	60
100	0	0	0	0	0	0	0	0	26	16	0	0	42
75	0	0	0	34	6	1	5	20	39	1	0	0	106
50	0	0	1	27	42	2	28	29	9	0	0	0	138
25	0	18	65	141	46	7	6	4	0	0	0	0	287
0	75	608	202	12	0	0	0	0	0	0	0	0	897
<b>Total</b>	<b>79</b>	<b>626</b>	<b>268</b>	<b>214</b>	<b>94</b>	<b>10</b>	<b>39</b>	<b>53</b>	<b>94</b>	<b>75</b>	<b>112</b>	<b>15</b>	<b>1679</b>

**Table 35. SCDNR rotenone survey standardized index of year class relative abundance. RSE = relative standard error; lower and upper refer to the lower and upper bounds of a 95% CI as estimated using estimated marginal means. CPUE refers to the index on the catch scale; Relative abundance is the index and confidence intervals normalized to the mean index value over all years of the survey.**

Year Class	Collections	% Positive	Red Drum	CPUE Index					Relative Abundance		
				CPUE	SE	RSE	Lower	Upper	Index	Lower	Upper
1985	8	50.00%	9	3.52	2.694	0.766	0.78	15.88	1.09	0.24	4.94
1986	49	67.35%	561	7.02	2.982	0.425	3.04	16.20	2.18	0.95	5.03
1987	46	54.35%	169	4.05	1.828	0.452	1.66	9.85	1.26	0.52	3.06
1988	15	33.33%	12	1.17	0.747	0.639	0.33	4.11	0.36	0.10	1.28
1989	50	44.00%	247	2.04	0.930	0.456	0.83	5.01	0.63	0.26	1.56
1990	47	72.34%	455	5.66	2.724	0.481	2.20	14.60	1.76	0.68	4.54
1991	44	54.55%	287	2.24	1.107	0.495	0.84	5.93	0.69	0.26	1.84
1992	16	37.50%	8	0.70	0.453	0.651	0.19	2.51	0.22	0.06	0.78
1993	16	43.75%	27	2.57	1.463	0.570	0.84	7.88	0.80	0.26	2.45

**Table 36. Fixed stations sampled by year as part of the SCDNR stop net survey. Collections sites are arranged via South Carolina estuary, from the South to the North. Note, year represents calendar year (Jan. 1 – Dec. 31) though the index was developed using fishing years (Sept. 1 – Aug. 31). Gray shaded cells are the years and sites considered for initial index development, prior to subsequent sub-sampling based on availability of other covariate information.**

Year	Port Royal Sound		Triple Creek*	Charleston Harbor			Bulls Bay		Town Creek^	Total
	Callawassie Creek	Turtle Creek		Crab Bank	Ft. Sumter	Grice Cove	Anderson Creek	Bulls Island		
1985	-	-	-	-	-	1	-	-	-	1
1986	-	-	-	-	-	6	-	-	-	6
1987	-	-	1	1	-	14	-	-	-	16
1988	-	-	-	-	1	13	-	-	-	14
1989	4	2	-	-	5	13	1	1	1	27
1990	-	1	-	-	-	12	-	7	-	20
1991	-	-	-	-	-	13	-	4	-	17
1992	-	-	-	-	-	13	-	4	-	17
1993	-	-	-	-	-	12	-	5	-	17
1994	-	-	-	-	-	9	-	2	-	11
1995	-	-	-	-	-	1	-	-	-	1
1996	-	-	-	-	-	1	-	1	-	2
1997	-	-	-	-	-	-	-	-	-	0
1998	-	-	-	-	-	1	-	-	-	1
<b>Total</b>	<b>4</b>	<b>3</b>	<b>1</b>	<b>1</b>	<b>6</b>	<b>109</b>	<b>1</b>	<b>24</b>	<b>1</b>	<b>150</b>

\* - St. Helena Sound / ACE Basin

^ - North Inlet

**Table 37. SCDNR stop net survey standardized index of relative abundance. RSE = relative standard error; lower and upper refer to the lower and upper bounds of a 95% CI as estimated using estimated marginal means. CPUE refers to the index on the catch scale; Relative abundance is the index and confidence intervals normalized to the mean index value over all years of the survey.**

Fishing Year	Collections	% Positive	Red Drum	CPUE Index			Relative Abundance				
				CPUE	SE	RSE	Lower	Upper	Index	Lower	Upper
1986	13	92.31%	633	28.38	7.925	0.279	16.32	49.35	0.81	0.46	1.40
1987	13	92.31%	905	38.86	10.830	0.279	22.37	67.50	1.11	0.64	1.92
1988	13	100.00%	842	35.77	10.262	0.287	20.26	63.15	1.02	0.58	1.80
1989	19	94.74%	1051	31.21	8.103	0.260	18.65	52.20	0.89	0.53	1.49
1990	18	100.00%	977	34.07	8.304	0.244	21.02	55.22	0.97	0.60	1.57
1991	17	100.00%	1263	43.63	10.870	0.249	26.63	71.48	1.24	0.76	2.03
1992	16	100.00%	956	36.95	9.165	0.248	22.60	60.41	1.05	0.64	1.72
1993	15	100.00%	777	32.25	8.542	0.265	19.08	54.51	0.92	0.54	1.55

**Table 38. Fishing years (and months within years) individual contemporary strata have been sampled as part of the SCDNR trammel net survey since 1990. Shaded cells include the years (and months) included in the development of relative abundance indices for individual species.**

Fishing Year	Port Royal Sound <sup>a</sup>		St. Helena Sound	Charleston Harbor			Cape Romain <sup>b</sup>			Winyah bay
	CT	BR	AB	AR	CH	LW	CR	MB	RH	WB
1990	-	-	June	Nov	Nov-Aug	Nov-Aug	Feb-Apr	-	Feb-Apr	-
1991	-	-	-	Jul-Aug	Sept-Aug	Sept-Aug	-	-	-	-
1992	-	-	-	Jan-Aug	Sept-Aug	Sept-Aug	-	-	-	Oct-Aug
1993	Aug	-	Jan-Aug	Sept-Aug	Sept-Aug	Sept-Aug	Jan-Aug	Oct-Nov	Oct-Jul	Sept-June
1994	Oct-Dec	-	Sept-Aug	Sept-Aug	Sept-Aug	Sept-Aug	Sept-Aug	Aug	Oct-Aug	-
1995	-	-	Sept-Aug	Sept-Aug	Sept-Aug	Sept-Aug	Sept-Aug	July-Aug	July-Aug	-
1996	June-Aug	-	Sept-Aug	Sept-Aug	Sept-Aug	Sept-Aug	Sept-Aug	Sept-Aug	Sept-Aug	-
1997	Sept-July	Oct-Aug	Sept-Aug	Sept-Aug	Sept-Aug	Sept-Aug	-	Sept-Aug	Sept-Aug	-
1998	Sept-Mar	Oct-Mar	Sept-Aug	Sept-Aug	Sept-Aug	Sept-Aug	-	Sept-Aug	Sept-Aug	-
1999	-	-	Sept-Aug	Sept-Aug	Sept-Aug	Sept-Aug	-	Sept-Aug	Sept-Aug	-
2000	-	-	Sept-Aug	Sept-Aug	Sept-Aug	Sept-Aug	-	Sept-Aug	Sept-Aug	June
2001	-	-	Sept-Aug	Sept-Aug	Sept-Aug	Sept-Aug	-	Sept-Aug	Sept-Aug	July-Aug
2002	June	-	Sept-Aug	Sept-Aug	Sept-Aug	Sept-Aug	-	Sept-Aug	Sept-Aug	Jan-Aug
2003	-	-	Sept-Aug	Sept-Aug	Sept-Aug	Sept-Aug	-	Sept-Aug	Sept-Aug	Sept-Aug
2004	-	-	Sept-Aug	Sept-Aug	Sept-Aug	Sept-Aug	-	Sept-Aug	Sept-Aug	Sept-Aug
2005	-	-	Sept-Aug	Sept-Aug	Sept-Aug	Sept-Aug	-	Sept-Aug	Sept-Aug	Sept-Aug
2006	-	-	Sept-Aug	Sept-Aug	Sept-Aug	Sept-Aug	-	Sept-Aug	Sept-Aug	Sept-Aug
2007	-	-	Sept-Aug	Sept-Aug	Sept-Aug	Sept-Aug	-	Sept-Aug	Sept-Aug	Sept-Aug
2008	Aug	Aug	Sept-Aug	Sept-Aug	Sept-Aug	Sept-Aug	-	Sept-Aug	Sept-Aug	Sept-Aug
2009	Sept-Aug	Sept-Aug	Sept-Aug	Sept-Aug	Sept-Aug	Sept-Aug	-	Sept-Aug	Sept-Aug	Sept-Aug
2010	Sept-Aug	Sept-Aug	Sept-Aug	Sept-Aug	Sept-Aug	Sept-Aug	-	Sept-Aug	Sept-Aug	Sept-Aug
2011	Sept-Aug	Sept-Aug	Sept-Aug	Sept-Aug	Sept-Aug	Sept-Aug	-	Sept-Aug	Sept-Aug	Sept-Aug
2012	Sept-Aug	Sept-Aug	Sept-Aug	Sept-Aug	Sept-Aug	Sept-Aug	-	Sept-Aug	Sept-Aug	Sept-Aug
2013	Sept-Aug	Sept-Aug	Sept-Aug	Sept-Aug	Sept-Aug	Sept-Aug	-	Sept-Aug	Sept-Aug	Sept-Aug
2014	Sept-Aug	Sept-Aug	Sept-Aug	Sept-Aug	Sept-Aug	Sept-Aug	-	Sept-Aug	Sept-Aug	Sept-Aug
2015	Sept-Aug	Sept-Aug	Sept-Aug	Sept-Aug	Sept-Aug	Sept-Aug	-	Sept-Aug	Sept-Aug	Sept-Aug
2016	Sept-Aug	Sept-Aug	Sept-Aug	Sept-Aug	Sept-Aug	Sept-Aug	-	Sept-Aug	Sept-Aug	Sept-Aug

Estuary	Port Royal Sound <sup>a</sup>		St. Helena Sound	Charleston Harbor			Cape Romain <sup>b</sup>			Winyah bay
	CT	BR	AB	AR	CH	LW	CR	MB	RH	WB
2017	Sept-Aug	Sept-Aug	Sept-Aug	Sept-Aug	Sept-Aug	Sept-Aug	-	Sept-Aug	Sept-Aug	Sept-Aug
2018	Sept-Aug	Sept-Aug	Sept-Aug	Sept-Aug	Sept-Aug	Sept-Aug	-	Sept-Aug	Sept-Aug	Sept-Aug
2019 <sup>c,d</sup>	Sept-Aug	Sept-Aug	Sept-Aug	Sept-Aug	Sept-Aug	Sept-Aug	-	Sept-Aug	Sept-Aug	Sept-Aug
2020 <sup>c,d</sup>	Sept-Aug	Sept-Aug	Sept-Aug	Sept-Aug	Sept-Aug	Sept-Aug	-	Sept-Aug	Sept-Aug	Sept-Aug
2021 <sup>d</sup>	Sept-Aug	Sept-Aug	Sept-Aug	Sept-Aug	Sept-Aug	Sept-Aug	-	Sept-Aug	Sept-Aug	Sept-Aug
2022 <sup>d</sup>	Sept-Aug	Sept-Aug	Sept-Aug	Sept-Aug	Sept-Aug	Sept-Aug	-	Sept-Aug	Sept-Aug	Sept-Aug

<sup>a</sup> - Only quarterly sampling occurred in Port Royal Sound through June 2020 with two strata being defined and sampled, Colleton River (CT) and Broad River (BR)

<sup>b</sup> - The Cape Romain strata has undergone revision through time. From calendar year 1994-1996 there was a single stratum sampled, referred to as the Cape Romain (CR) stratum; from 1997 thru June 2020, two strata were sampled monthly, called Muddy & Bulls Bay (MB) and Romain Harbor (RH), with both strata being expansions of the original geographic footprint of the original Cape Romain strata (original stations became seed members of the two new strata with additional stations created. This splitting of strata was necessary due to safety concerns and the geographic footprint of the original strata (to large of an area for field crews to safely support each other in the field).

<sup>c</sup> - Sampling in 2020 was affected due to social distancing protocols put into place due to COVID-19 as well as a survey design change that was implemented in July 2020 (see below for details). Sampling was halted midway through March 2020 monthly sampling, with no sampling in April-June. Sampling resumed in July, but was limited through August, with sampling under the new survey intensity fully implemented in September 2020

<sup>d</sup> - To ensure financial solvency of the survey while maintaining the continuity of the long-term survey, the sampling intensity of the survey was modified in July 2020. Changes included 1) a merging of the traditional Colleton River and Broad River strata in Port Royal Sound into the combined Port Royal Sound Stratum, 2) a merging of the traditional Muddy & Bulls Bay (MB) and Romain Harbor (RH) strata into the combined Cape Romain stratum with only stations in either the traditional MB or RH stratum selected for sampling in a given sampling month, and 3) moving to sampling the remaining seven strata twice per quarter instead of the traditional monthly sampling employed in most strata prior (increased frequency of within year sampling in Port Royal Sound; decreased frequency of within year sampling in other strata).



**Table 39. By fishing year, number of trammel net collections made in the contemporary strata. Shown is the total number of collections, including those not deemed suitable for index development but useful for collection of life history samples, and the number of collections retained for index development (in parentheses).**

Fishing Year	Port Royal Sound		St. Helena Sound	Charleston Harbor			Cape Romain			Winyah bay	Total
	CT	BR	AB	AR	CH	LW	CR	MB	RH	WB	
1990	-	-	1 (0)	4 (0)	76 (40)	131 (54)	19 (0)	-	4 (0)	-	<b>235 (94)</b>
1991	-	-	-	1'-	57 (55)	106 (93)	-	-	-	-	<b>173 (148)</b>
1992	-	-	-	108 (71)	62 (59)	119 (117)	-	-	-	3'-	<b>319 (247)</b>
1993	1 (0)	-	70 (64)	122 (115)	80 (76)	118 (111)	61 (57)	15 (0)	20 (5)	24 (0)	<b>511 (428)</b>
1994	2 (0)	-	143 (123)	167 (141)	131 (116)	151 (136)	137 (114)	2 (2)	6 (6)	-	<b>739 (638)</b>
1995	-	-	147 (139)	156 (144)	135 (131)	141 (132)	141 (137)	4 (4)	8 (8)	-	<b>732 (695)</b>
1996	5 (0)	-	154 (146)	179 (172)	164 (163)	154 (146)	119 (117)	34 (22)	37 (35)	-	<b>846 (801)</b>
1997	12 (0)	13 (0)	155 (154)	166 (163)	209 (176)	143 (140)	-	138 (110)	137 (129)	-	<b>973 (872)</b>
1998	6 (0)	7 (0)	153 (150)	168 (164)	227 (182)	171 (166)	-	166 (166)	143 (142)	-	<b>1041 (970)</b>
1999	-	-	151 (149)	160 (156)	227 (159)	145 (142)	-	143 (143)	149 (149)	-	<b>975 (898)</b>
2000	-	-	131 (128)	163 (163)	133 (131)	136 (136)	-	127 (126)	134 (134)	1 (0)	<b>825 (818)</b>
2001	-	-	153 (152)	162 (162)	141 (136)	153 (149)	-	129 (127)	137 (137)	11 (0)	<b>886 (863)</b>
2002	4 (0)	-	135 (134)	161 (161)	125 (123)	135 (135)	-	125 (124)	124 (123)	105 (72)	<b>914 (872)</b>
2003	-	-	128 (128)	164 (164)	133 (131)	138 (137)	-	136 (136)	144 (144)	119 (118)	<b>962 (958)</b>
2004	-	-	141 (141)	156 (156)	133 (128)	136 (135)	-	139 (139)	143 (143)	129 (127)	<b>977 (969)</b>
2005	-	-	126 (123)	165 (163)	129 (127)	136 (134)	-	141 (141)	128 (128)	136 (136)	<b>961 (952)</b>
2006	-	-	120 (118)	159 (157)	123 (121)	142 (140)	-	123 (123)	136 (136)	120 (120)	<b>923 (915)</b>
2007	-	-	132 (131)	173 (156)	126 (126)	143 (141)	-	141 (141)	120 (119)	125 (125)	<b>960 (939)</b>
2008	14 (0)	11 (0)	121 (119)	149 (148)	112 (110)	131 (130)	-	132 (131)	125 (125)	108 (107)	<b>903 (870)</b>
2009	52 (39)	52 (39)	137 (136)	159 (159)	126 (126)	130 (129)	-	113 (113)	140 (138)	94 (94)	<b>1003 (973)</b>
2010	50 (50)	45 (45)	148 (147)	153 (152)	135 (127)	138 (137)	-	121 (121)	151 (151)	122 (122)	<b>1063 (1052)</b>
2011	44 (43)	49 (49)	150 (150)	157 (156)	134 (127)	125 (125)	-	139 (139)	151 (151)	134 (132)	<b>1083 (1072)</b>
2012	47 (46)	31 (31)	135 (133)	145 (144)	124 (120)	131 (129)	-	120 (120)	123 (119)	111 (111)	<b>967 (953)</b>
2013	38 (38)	20 (20)	116 (116)	150 (148)	131 (122)	133 (131)	-	115 (115)	123 (123)	126 (126)	<b>952 (939)</b>
2014	13 (13)	12 (12)	123 (121)	144 (144)	121 (119)	131 (128)	-	111 (111)	126 (126)	115 (115)	<b>896 (889)</b>
2015	44 (42)	40 (39)	123 (122)	145 (142)	121 (120)	135 (130)	-	127 (125)	125 (124)	119 (118)	<b>979 (962)</b>
2016	31 (30)	26 (25)	122 (119)	138 (128)	113 (109)	119 (115)	-	101 (99)	120 (119)	134 (127)	<b>904 (871)</b>
2017	44 (42)	33 (32)	111 (104)	128 (123)	99 (95)	111 (108)	-	110 (106)	130 (128)	126 (123)	<b>892 (861)</b>
2018	42 (41)	40 (39)	113 (108)	141 (140)	110 (108)	121 (118)	-	126 (124)	128 (127)	129 (129)	<b>950 (934)</b>
2019	30 (30)	30 (30)	84 (81)	102 (101)	86 (84)	96 (94)	-	84 (84)	69 (69)	83 (82)	<b>664 (655)</b>
2020	50 (48)	43 (42)	93 (92)	94 (94)	87 (86)	91 (90)	-	45 (44)	56 (56)	90 (89)	<b>649 (641)</b>
2021	40 (36)	41 (41)	99 (98)	93 (91)	91 (89)	87 (86)	-	39 (39)	47 (45)	92 (91)	<b>629 (616)</b>
2022	79 (77)	84 (84)	71 (70)	100 (100)	68 (67)	95 (91)	-	67 (66)	79 (77)	97 (97)	<b>740 (729)</b>
<b>Total</b>	<b>648 (575)</b>	<b>577 (528)</b>	<b>3,786 (3,696)</b>	<b>4,541 (4,378)</b>	<b>4,069 (3,789)</b>	<b>4,272 (4,085)</b>	<b>477 (425)</b>	<b>3,113 (3,041)</b>	<b>3,263 (3,216)</b>	<b>2,480 (2,361)</b>	<b>27,226 (26,094)</b>

**Table 40. SCDNR trammel net survey standardized index of relative abundance. RSE = relative standard error; lower and upper refer to the lower and upper bounds of a 95% CI as estimated using estimated marginal means. CPUE refers to the index on the catch scale; Relative abundance is the index and confidence intervals normalized to the mean index value over all years of the survey.**

Year	Collections	% Positive	Red Drum	CPUE Index				Relative Abundance			
				CPUE	SE	RSE	Lower	Upper	Index	Lower	Upper
1991	147	63.27%	1,286	3.10	0.542	0.175	2.20	4.36	2.44	1.73	3.44
1992	244	53.69%	1,530	2.27	0.310	0.137	1.73	2.97	1.79	1.37	2.34
1993	416	55.29%	2,766	2.19	0.246	0.113	1.76	2.73	1.73	1.39	2.15
1994	630	49.21%	2,208	1.31	0.132	0.100	1.08	1.59	1.03	0.85	1.26
1995	688	47.53%	3,402	1.88	0.181	0.096	1.56	2.27	1.48	1.23	1.79
1996	794	44.96%	3,034	1.15	0.109	0.095	0.95	1.38	0.91	0.75	1.09
1997	868	45.62%	2,567	1.05	0.095	0.090	0.88	1.26	0.83	0.70	0.99
1998	967	40.23%	2,451	0.83	0.074	0.090	0.69	0.99	0.65	0.55	0.78
1999	892	37.00%	1,543	0.63	0.059	0.093	0.53	0.76	0.50	0.42	0.60
2000	816	42.52%	2,890	1.32	0.122	0.092	1.10	1.59	1.04	0.87	1.25
2001	859	53.32%	3,626	1.60	0.142	0.089	1.35	1.91	1.26	1.06	1.50
2002	871	51.32%	4,268	1.79	0.158	0.088	1.50	2.12	1.41	1.19	1.68
2003	956	56.17%	5,385	2.08	0.177	0.085	1.76	2.45	1.64	1.39	1.94
2004	969	52.53%	4,220	1.88	0.162	0.086	1.59	2.22	1.48	1.25	1.75
2005	950	50.84%	4,052	1.66	0.144	0.087	1.40	1.96	1.31	1.10	1.55
2006	915	41.64%	2,233	0.87	0.078	0.091	0.73	1.03	0.68	0.57	0.82
2007	938	44.46%	2,862	1.08	0.096	0.089	0.90	1.28	0.85	0.71	1.01
2008	869	45.91%	2,897	1.19	0.107	0.090	1.00	1.42	0.94	0.79	1.12
2009	959	46.09%	3,731	1.63	0.141	0.087	1.37	1.93	1.28	1.08	1.52
2010	1,048	46.09%	3,743	1.34	0.115	0.086	1.13	1.58	1.05	0.89	1.25
2011	1,067	37.86%	2,520	0.91	0.079	0.087	0.77	1.08	0.72	0.61	0.85
2012	953	34.73%	1,894	0.79	0.072	0.091	0.66	0.94	0.62	0.52	0.75
2013	938	38.49%	2,097	0.99	0.090	0.090	0.83	1.18	0.78	0.65	0.93
2014	889	31.95%	1,258	0.79	0.074	0.094	0.66	0.95	0.62	0.52	0.75
2015	959	31.80%	1,513	0.74	0.068	0.091	0.62	0.89	0.59	0.49	0.70
2016	870	31.72%	1,149	0.61	0.058	0.096	0.50	0.73	0.48	0.40	0.58
2017	857	28.24%	1,496	0.82	0.078	0.094	0.68	0.99	0.65	0.54	0.78
2018	933	31.08%	1,443	0.73	0.068	0.093	0.61	0.88	0.58	0.48	0.70
2019	654	23.70%	535	0.49	0.054	0.110	0.39	0.61	0.39	0.31	0.48
2020	636	37.89%	1,090	0.96	0.100	0.104	0.78	1.18	0.76	0.62	0.93
2021	614	31.92%	896	0.78	0.083	0.107	0.63	0.96	0.62	0.50	0.76
2022	722	38.78%	1,687	1.11	0.110	0.099	0.92	1.35	0.88	0.72	1.06

**Table 41. Fixed stations sampled by year as part of the SCDNR historic longline survey that were considered during index development. Collection sites are arranged from inshore to offshore North. Given the seasonal nature of the survey, collections made from August-December in a given calendar year (Year) was used to represent adult red drum abundance during that fishing year (e.g., fishing year = calendar year for survey).**

<b>Year</b>	<b>South Jetties</b>	<b>North Jetties</b>	<b>Old C-6</b>	<b>Humps</b>	<b>2 Charlie</b>	<b>Total</b>
1994	-	-	58	-	-	<b>58</b>
1995	-	-	86	-	-	<b>86</b>
1996	-	-	99	-	13	<b>112</b>
1997	-	-	93	-	12	<b>105</b>
1998	-	-	74	30	9	<b>113</b>
1999	-	-	65	14	23	<b>102</b>
2000	-	22	42	13	9	<b>86</b>
2001	-	27	36	15	15	<b>93</b>
2002	14	37	16	8	6	<b>81</b>
2003	24	21	36	8	2	<b>91</b>
2004	24	12	34	3	5	<b>78</b>
2005	15	8	4	-	1	<b>28</b>
2006	26	21	3	-	-	<b>50</b>
<b>Total</b>	<b>103</b>	<b>148</b>	<b>646</b>	<b>91</b>	<b>95</b>	<b>1,083</b>

**Table 42. SCDNR historic longline survey standardized index of relative abundance. RSE = relative standard error; lower and upper refer to the lower and upper bounds of a 95% CI as estimated using estimated marginal means. CPUE refers to the index on the catch scale, in this case catch per 120 hooks; Relative abundance is the index and confidence intervals normalized to the mean index value over all years of the survey.**

Year	Collections	% Positive	CPUE Index			Relative Abundance				
			CPUE	SE	RSE	Lower	Upper	Index	Lower	Upper
1994	58	44.83%	4.53	0.940	0.208	3.01	6.81	1.11	0.74	1.67
1995	86	54.65%	5.41	0.991	0.183	3.78	7.75	1.33	0.93	1.90
1996	112	58.93%	4.84	0.773	0.160	3.54	6.63	1.19	0.87	1.63
1997	105	44.76%	2.01	0.375	0.186	1.40	2.90	0.49	0.34	0.71
1998	113	53.10%	3.24	0.539	0.166	2.34	4.49	0.80	0.57	1.10
1999	102	73.53%	4.98	0.826	0.166	3.60	6.90	1.22	0.88	1.69
2000	86	56.98%	2.77	0.481	0.174	1.97	3.89	0.68	0.48	0.95
2001	93	69.89%	4.11	0.667	0.162	2.99	5.65	1.01	0.73	1.39
2002	81	77.78%	4.77	0.829	0.174	3.39	6.71	1.17	0.83	1.65
2003	91	83.52%	5.45	0.897	0.165	3.94	7.52	1.34	0.97	1.85
2004	78	65.38%	3.69	0.645	0.175	2.62	5.20	0.90	0.64	1.28
2005	28	67.86%	4.56	1.502	0.329	2.39	8.70	1.12	0.59	2.13
2006	50	64.00%	2.62	0.626	0.238	1.64	4.19	0.64	0.40	1.03

**Table 43. Fishing years (and months within years) individual contemporary strata have been sampled as part of the SCDNR electrofishing survey since 2000.**

Estuary	St. Helena Sound		Charleston Harbor		Winyah bay
	Combahee River	Edisto River	Ashley River	Cooper River	Waccamaw/Sampit Rivers
2000	Apr-Aug	Mar-Aug	Feb-Aug	Mar-Aug	-
2001	Sept-Aug	Sept-Aug	Sept-Aug	Sept-Aug	-
2002	Sept-Aug	Sept-Aug	Sept-Aug	Sept-Aug	-
2003	Sept-Aug	Sept-Aug	Sept-Aug	Sept-Aug	Sept-Aug
2004	Sept-Aug	Sept-Aug	Sept-Aug	Sept-Aug	Sept-Aug
2005	Sept-Aug	Sept-Aug	Sept-Aug	Sept-Aug	Sept-Aug
2006	Sept-Aug	Sept-Aug	Sept-Aug	Sept-Aug	Sept-Aug
2007	Sept-Aug	Sept-Aug	Sept-Aug	Sept-Aug	Sept-Aug
2008	Sept-Aug	Sept-Aug	Sept-Aug	Sept-Aug	Sept-Aug
2009	Sept-Aug	Sept-Aug	Sept-Aug	Sept-Aug	Sept-Aug
2010	Sept-Aug	Sept-Aug	Sept-Aug	Sept-Aug	Sept-Aug
2011	Sept-Aug	Sept-Aug	Sept-Aug	Sept-Aug	Sept-Aug
2012	Sept-Aug	Sept-Aug	Sept-Aug	Sept-Aug	Sept-Aug
2013	Sept-Aug	Sept-Aug	Sept-Aug	Sept-Aug	Sept-Aug
2014	Sept-Aug	Sept-Aug	Sept-Aug	Sept-Aug	Sept-Aug
2015	Sept-Aug	Sept-Aug	Sept-Aug	Sept-Aug	Sept-Aug
2016	Sept-Aug	Sept-Aug	Sept-Aug	Sept-Aug	Sept-Aug
2017	Sept-Aug	Sept-Aug	Sept-Aug	Sept-Aug	Sept-Aug
2018	Sept-Aug	Sept-Aug	Sept-Aug	Sept-Aug	Sept-Aug
2019 <sup>a,b</sup>	Sept-Aug	Sept-Aug	Sept-Aug	Sept-Aug	Sept-Aug
2020 <sup>a,b</sup>	Sept-Aug	Sept-Aug	Sept-Aug	Sept-Aug	Sept-Aug
2021 <sup>b</sup>	Sept-Aug	Sept-Aug	Sept-Aug	Sept-Aug	Sept-Aug
2022 <sup>b</sup>	Sept-Aug	Sept-Aug	Sept-Aug	Sept-Aug	Sept-Aug

<sup>a</sup> - Sampling in 2020 was affected due to social distancing protocols put into place due to COVID-19 as well as a survey design change that was implemented in July 2020 (see below for details). Sampling was halted midway through March 2020 monthly sampling, with no sampling in April-May. Sampling resumed in June under a new survey intensity

<sup>b</sup> - To ensure financial solvency of the survey while maintaining the continuity of the long-term survey, the sampling intensity of the survey was modified in June 2020. Changes included moving from monthly sampling of each stratum, to sampling each stratum five of every six months (10 times annually).

**Table 44. By fishing year, number of electrofishing collections made in the contemporary strata.**

Estuary	St. Helena Sound		Charleston Harbor		Winyah bay	Total
	Combahee River	Edisto River	Ashley River	Cooper River	Waccamaw/Sampit Rivers	
2000	17	20	21	26		84
2001	63	67	73	68		271
2002	58	68	72	67		265
2003	62	53	65	73	47	300
2004	53	61	67	66	61	308
2005	58	59	65	71	59	312
2006	62	65	73	61	71	332
2007	61	50	62	67	42	282
2008	65	57	67	69	65	323
2009	66	64	67	70	59	326
2010	56	50	67	63	53	289
2011	71	62	69	65	64	331
2012	61	68	56	57	58	300
2013	56	61	67	67	64	315
2014	67	59	69	59	54	308
2015	66	52	67	62	66	313
2016	65	58	61	60	52	296
2017	62	63	82	78	56	341
2018	64	60	67	69	64	324
2019	49	36	47	52	51	235
2020	57	53	54	47	59	270
2021	48	60	37	49	52	246
2022	64	54	50	50	43	261
<b>Total</b>	<b>1,351</b>	<b>1,300</b>	<b>1,425</b>	<b>1,416</b>	<b>1,140</b>	<b>6,632</b>

**Table 45. SCDNR electrofishing survey standardized index of relative abundance. RSE = relative standard error; lower and upper refer to the lower and upper bounds of a 95% CI as estimated using estimated marginal means. CPUE refers to the index on the catch scale, in this case catch per 15 minutes electrofishing; Relative abundance is the index and confidence intervals normalized to the mean index value over all years of the survey.**

Year	Collections	% Positive	Red Drum	CPUE Index					Relative Abundance		
				CPUE	SE	RSE	Lower	Upper	Index	Lower	Upper
2001	250	59.60%	631	1.95	0.198	0.102	1.59	2.37	1.00	0.82	1.22
2002	253	62.45%	774	2.91	0.280	0.096	2.41	3.52	1.49	1.24	1.80
2003	292	58.56%	1,035	2.59	0.230	0.089	2.17	3.08	1.33	1.11	1.58
2004	299	55.52%	668	1.51	0.140	0.093	1.26	1.81	0.77	0.64	0.93
2005	303	52.81%	696	1.58	0.145	0.092	1.32	1.89	0.81	0.68	0.97
2006	322	51.55%	535	1.29	0.121	0.094	1.07	1.55	0.66	0.55	0.79
2007	264	58.33%	562	1.79	0.180	0.101	1.47	2.18	0.92	0.75	1.12
2008	310	60.32%	917	2.38	0.209	0.088	2.01	2.83	1.22	1.03	1.45
2009	317	58.99%	939	2.57	0.226	0.088	2.16	3.05	1.31	1.11	1.56
2010	280	59.64%	706	2.12	0.204	0.096	1.76	2.56	1.09	0.90	1.31
2011	323	58.20%	844	2.14	0.191	0.089	1.79	2.54	1.09	0.92	1.30
2012	294	57.48%	993	2.91	0.260	0.089	2.44	3.47	1.49	1.25	1.78
2013	310	53.23%	647	1.87	0.169	0.090	1.57	2.23	0.96	0.80	1.14
2014	297	47.81%	525	1.76	0.166	0.094	1.46	2.12	0.90	0.75	1.08
2015	300	49.00%	489	1.61	0.151	0.094	1.34	1.93	0.82	0.69	0.99
2016	284	57.39%	644	2.34	0.220	0.094	1.94	2.81	1.20	1.00	1.44
2017	339	61.06%	730	1.88	0.164	0.087	1.58	2.23	0.96	0.81	1.14
2018	311	50.80%	638	1.80	0.165	0.092	1.50	2.15	0.92	0.77	1.10
2019	220	39.55%	289	1.07	0.122	0.114	0.85	1.33	0.55	0.44	0.68
2020	260	38.46%	244	0.87	0.098	0.113	0.70	1.08	0.44	0.36	0.56
2021	228	42.98%	251	1.03	0.120	0.117	0.82	1.29	0.53	0.42	0.66
2022	244	64.34%	704	2.99	0.296	0.099	2.46	3.63	1.53	1.26	1.86

**Table 46. By year, number of SCDNR contemporary longline collections made. Shown is the total number of collections, including those not deemed suitable for index development but useful for collection of life history samples, and the number of collections retained for index development (in parentheses) by strata.**

Year	Port Royal Sound		St. Helena Sound		Charleston Harbor		Winyah Bay		Total		Combined
	Inshore	Offshore	Inshore	Offshore	Inshore	Offshore	Inshore	Offshore	Inshore	Offshore	
2007	49 (18)	38 (23)	52 (8)	47 (22)	34 (16)	50 (30)	35 (30)	46 (37)	<b>170 (72)</b>	<b>181 (112)</b>	<b>351 (184)</b>
2008	85 (16)	57 (22)	70 (8)	76 (18)	63 (28)	88 (52)	43 (18)	97 (45)	<b>261 (70)</b>	<b>318 (137)</b>	<b>579 (207)</b>
2009	56 (23)	30 (16)	52 (15)	38 (22)	29 (17)	66 (62)	33 (29)	54 (49)	<b>170 (84)</b>	<b>188 (149)</b>	<b>358 (233)</b>
2010	52 (31)	62 (56)	31 (31)	61 (56)	36 (30)	59 (56)	32 (32)	58 (58)	<b>151 (124)</b>	<b>240 (226)</b>	<b>391 (350)</b>
2011	36 (34)	54 (54)	34 (34)	57 (56)	37 (32)	66 (59)	33 (33)	57 (57)	<b>140 (133)</b>	<b>234 (226)</b>	<b>374 (359)</b>
2012	34 (31)	56 (56)	38 (35)	71 (54)	32 (31)	61 (60)	28 (28)	65 (62)	<b>132 (125)</b>	<b>253 (232)</b>	<b>385 (357)</b>
2013	30 (29)	79 (60)	41 (41)	49 (49)	31 (29)	61 (60)	34 (33)	54 (54)	<b>136 (132)</b>	<b>243 (223)</b>	<b>379 (355)</b>
2014	29 (27)	75 (63)	38 (38)	52 (52)	28 (28)	62 (62)	30 (30)	60 (58)	<b>125 (123)</b>	<b>249 (235)</b>	<b>374 (358)</b>
2015	28 (28)	62 (62)	31 (31)	59 (57)	31 (31)	54 (54)	22 (22)	38 (38)	<b>112 (112)</b>	<b>213 (211)</b>	<b>325 (323)</b>
2016	36 (36)	54 (54)	29 (29)	61 (61)	33 (28)	66 (62)	30 (30)	56 (56)	<b>128 (123)</b>	<b>237 (233)</b>	<b>365 (356)</b>
2017	28 (28)	62 (62)	36 (36)	54 (54)	27 (26)	60 (60)	29 (29)	61 (61)	<b>120 (119)</b>	<b>237 (237)</b>	<b>357 (356)</b>
2018	30 (30)	60 (60)	39 (39)	51 (51)	29 (29)	61 (61)	28 (28)	59 (59)	<b>126 (126)</b>	<b>231 (231)</b>	<b>357 (357)</b>
2019	25 (25)	62 (62)	28 (27)	56 (56)	29 (29)	61 (61)	33 (33)	57 (57)	<b>115 (114)</b>	<b>236 (236)</b>	<b>351 (350)</b>
2020	31 (31)	59 (59)	33 (30)	58 (50)	29 (26)	61 (59)	29 (29)	61 (61)	<b>122 (116)</b>	<b>239 (229)</b>	<b>361 (345)</b>
2021	30 (30)	60 (60)	30 (30)	60 (60)	30 (30)	60 (60)	27 (21)	63 (59)	<b>117 (111)</b>	<b>243 (239)</b>	<b>360 (350)</b>
2022	20 (20)	36 (36)	35 (35)	50 (50)	31 (30)	45 (45)	26 (26)	55 (55)	<b>112 (111)</b>	<b>186 (186)</b>	<b>298 (297)</b>
<b>Total</b>	<b>599 (437)</b>	<b>906 (805)</b>	<b>617 (467)</b>	<b>900 (768)</b>	<b>529 (440)</b>	<b>981 (903)</b>	<b>492 (451)</b>	<b>941 (866)</b>	<b>2,237 (1,795)</b>	<b>3,728 (3,342)</b>	<b>5,965 (5,137)</b>



**Table 47. SCDNR contemporary longline survey standardized index of relative abundance. RSE = relative standard error; lower and upper refer to the lower and upper bounds of a 95% CI as estimated using estimated marginal means. CPUE refers to the index on the catch scale, in this case catch per 120 hooks; Relative abundance is the index and confidence intervals normalized to the mean index value over all years of the survey.**

Year	Collections	% Positive	Red Drum	CPUE Index					Relative Abundance		
				CPUE	SE	RSE	Lower	Upper	Index	Lower	Upper
2007	182	22.53%	112	2.21	0.627	0.284	1.26	3.85	1.08	0.62	1.89
2008	203	26.11%	132	2.57	0.713	0.278	1.49	4.43	1.26	0.73	2.17
2009	230	33.48%	311	5.00	1.352	0.271	2.94	8.49	2.45	1.44	4.17
2010	326	33.74%	392	1.27	0.210	0.165	0.92	1.76	0.62	0.45	0.86
2011	345	37.97%	388	1.11	0.190	0.172	0.79	1.55	0.54	0.39	0.76
2012	338	42.31%	616	2.20	0.383	0.174	1.56	3.09	1.08	0.77	1.52
2013	346	44.51%	604	1.89	0.330	0.174	1.35	2.66	0.93	0.66	1.31
2014	356	43.82%	570	1.80	0.329	0.183	1.26	2.57	0.88	0.62	1.26
2015	320	49.38%	825	1.93	0.356	0.184	1.35	2.77	0.95	0.66	1.36
2016	351	53.85%	989	2.42	0.436	0.180	1.70	3.44	1.19	0.83	1.69
2017	354	40.40%	515	1.53	0.291	0.191	1.05	2.22	0.75	0.52	1.09
2018	354	37.01%	639	2.23	0.430	0.193	1.52	3.25	1.09	0.75	1.60
2019	346	46.82%	639	2.27	0.419	0.185	1.58	3.26	1.11	0.77	1.60
2020	343	46.06%	694	1.75	0.321	0.183	1.23	2.51	0.86	0.60	1.23
2021	348	33.91%	433	1.30	0.245	0.189	0.90	1.88	0.64	0.44	0.93
2022	296	39.53%	422	1.11	0.220	0.199	0.75	1.63	0.54	0.37	0.80

**Table 48. Georgia Coastal Longline Survey sampling methodologies. November 2006 – December 2020.**

<b>Sampling Design</b>	
Nov 2006 – Dec 2006:	Pilot Season
Nov 2006 – Present:	Random stratified based on Region (SGA and NFL) and Zone (Estuary, 0-3nm, 3-12nm). Grids ½ x ½ nm. Sep - Dec station allocation shifts from inshore to offshore.
2007 –2011:	Adaptive approach employed for Red Drum Sampling
2018 –2022:	Region NFL dropped
<b>Sampling Period</b>	
2006 – 2017:	Monthly Sampling by Zone. 25 stations
2018 – 2022:	Quarterly Sampling by Zone. 6-week time frame. 35 stations.
<b>Bait Type</b>	
2006:	100% mackerel
2007:	50% of hooks mackerel, 50% squid
2008 – 2015:	100% squid
2016 – 2020:	50% of hooks mullet, 50% squid
2021 – 2022:	100% of hooks mullet
<b>Hook Size</b>	
2006 – 2007:	15/0
2008 – 2015:	50% of hooks 15/0, 50% 12/0
2016 – 2022:	15/0

**Table 49. Model structure of the 25 candidate models used to estimate apparent survival (Phi), and encounter probability (p) for red drum tagged and released during fisheries-independent sampling by the South Carolina Department of Natural Resources from 1990-2022. The column 'MODEL' indicates the candidate model structure, including variables of age, time, sampling period, and constant probabilities (~1) as potential explanatory factors. NPAR indicates the number of parameters estimated in the corresponding model structure, and DELTA\_AIC is the difference between that model's Akaike's information criterion value (AIC) and the lowest AIC value of all the candidate models.**

MODEL	NPAR	DELTA_AIC
Phi(~age * time)p(~age * period)	105	0
Phi(~age + time)p(~age)	37	1
Phi(~age * time)p(~age)	99	2
Phi(~age + time)p(~period + age)	39	2
Phi(~time)p(~age)	35	2
Phi(~age * time)p(~period + age)	101	2
Phi(~time)p(~period + age)	37	3
Phi(~time)p(~age * period)	41	8
Phi(~age * time)p(~1)	97	9
Phi(~age * time)p(~period)	99	9
Phi(~age + time)p(~1)	35	12
Phi(~age + time)p(~period)	37	13
Phi(~age + time)p(~age * period)	43	15
Phi(~1)p(~period + age)	6	37
Phi(~age)p(~period + age)	8	38
Phi(~1)p(~age * period)	10	41
Phi(~time)p(~1)	33	42
Phi(~age)p(~age * period)	12	42
Phi(~time)p(~period)	35	43
Phi(~age)p(~period)	6	49
Phi(~1)p(~age)	4	66
Phi(~age)p(~age)	6	66
Phi(~age)p(~1)	4	76
Phi(~1)p(~period)	4	76
Phi(~1)p(~1)	2	99

**Table 50. Length-length relationships estimated for red drum.**

Stock	Dep. Variable	Unit	Ind. Variable	Unit	n	a	SE	b	SE	r2	Dependent Range	Independent Range
Northern	Total Length	mm	Standard Length	mm	1,190	6.057	1.008	1.183	2.445E-03	0.995	227 - 1,258	190 - 1,067
Northern	Total Length	mm	Fork Length	mm	19,466	-23.907	0.185	1.089	3.281E-04	0.998	150 - 1,441	149 - 1,346
Northern	Fork Length	mm	Standard Length	mm	199	39.730	2.660	1.076	4.978E-03	0.996	285 - 1,168	240 - 1,041
Northern	Fork Length	mm	Total Length	mm	19,466	22.861	0.164	0.917	2.764E-04	0.998	190 - 1,067	227 - 1,258
Northern	Standard Length	mm	Fork Length	mm	199	-34.625	2.624	0.925	4.279E-03	0.996	149 - 1,346	150 - 1,441
Northern	Standard Length	mm	Total Length	mm	1,189	-3.140	0.858	0.841	1.738E-03	0.995	190 - 1,067	227 - 1,258
Southern	Total Length	mm	Standard Length	mm	52,909	8.095	0.091	1.200	2.240E-04	0.998	5 - 1,183	4 - 1,005
Southern	Total Length	mm	Fork Length	mm	20,366	-20.339	0.276	1.091	3.589E-04	0.998	19 - 1,246	19 - 1,154
Southern	Fork Length	mm	Standard Length	mm	8,184	30.551	0.363	1.087	7.232E-04	0.996	19 - 1,135	15 - 1,005
Southern	Fork Length	mm	Total Length	mm	20,366	20.206	0.247	0.914	3.007E-04	0.998	19 - 1,154	19 - 1,246
Southern	Standard Length	mm	Fork Length	mm	8,184	-26.355	0.350	0.917	6.098E-04	0.996	15 - 1,005	19 - 1,135
Southern	Standard Length	mm	Total Length	mm	52,909	-6.046	0.077	0.832	1.552E-04	0.998	4 - 1,005	5 - 1,183

**Table 51. Life history parameters used in SS models for red drum.**

Parameter	Stock		Source
	Northern	Southern	
Age-2 Natural Mortality	0.158	0.233	Section 2.5
Amin (age for first size-at-age, Lmin)	one month old	five months old	Section 2.3
Lmin (TL cm)	6	Estimated	NA
Linf (TL cm)	Estimated	Estimated	NA
Maximum age	62	41	Section 2.3
von Bertalanffy Base <i>K</i> (youngest ages)	Estimated	Estimated	NA
<i>K</i> age break points	2, 6	1, 6	Section 2.3
Age break point <i>K</i> multipliers	Estimated	Estimated	NA
Length-at-age CV for smallest sizes	Estimated	Estimated	NA
Length-at-age CV for largest sizes	Estimated	Estimated	NA
Length-weight relationship alpha (TL cm-kg)	1.12E-05	1.13E-05	Current Assessment
Length-weight relationship beta (TL cm-kg)	2.9861	2.9827	Current Assessment
Female 50% maturity (age)	3.5	4.2	Section 2.4
Female maturity slope	-4.28	-1.55	Section 2.4
R0 (thousands of fish)	Estimated	Estimated	NA
sigma R	0.70	0.37	r4ss
steepness	0.99	0.99	ASMFC 2022

**Table 52. Fishing mortality reference points and status measures for red drum analyses including the Stock Synthesis integrated model (SS), traffic light analysis (TLA), and Skate index-based method.**

Measure	Description	Type	Analysis
$SPR_{30\%}$	Static spawning potential ratio resulting in 30% of unfished equilibrium spawning stock biomass	Threshold	SS
$F_{30\%}$	Age-2 fishing mortality associated with $SPR_{30\%}$	Threshold	SS
$SPR_{40\%}$	Static spawning potential ratio resulting in 40% of unfished equilibrium spawning stock biomass	Target	SS
$F_{40\%}$	Age-2 fishing mortality associated with $SPR_{40\%}$	Target	SS
$\overline{SPR}_{y-2,y-1,y}$	Three-year running average static spawning potential ratio in year <i>y</i>	Population Measure	SS
$SPR\ Status_y$	Three-year running average SPR in year <i>y</i> relative to SPR threshold: $\overline{SPR}_{y-2,y-1,y} > SPR_{30\%} = \text{Not Overfishing}$ $\overline{SPR}_{y-2,y-1,y} \leq SPR_{30\%} = \text{Overfishing}$	Fishing Mortality Status	SS
Catch/Index	Ratio of the three year moving average of total catch divided by the three year moving average of an independent index.	Fishery Performance	Skate
Relative <i>F</i>	Median recommended fishing mortality based on the Catch/Index ratio.	Fishery Performance	Skate
%Reduction	Recommended reduction in fishing mortality when a stock is deemed to experience overfishing based on the Relative <i>F</i>		Skate

**Table 53. Biomass and abundance reference points and status measures for red drum analyses including the Stock Synthesis integrated model (SS) and traffic light analysis (TLA). Spawning stock biomass measures are in metric tons.**

Measure	Description	Type	Analysis
$SSB_{30\%}$	30% of unfished equilibrium spawning stock biomass	Threshold	SS
$SSB_{40\%}$	40% of unfished equilibrium spawning stock biomass	Target	SS
$\overline{SSB}_{y-2,y-1,y}$	Three-year running average spawning stock biomass in year $y$	Population Measure	SS
$SSB\ Status_y$	Three-year running average SSB in year $y$ relative to SSB threshold: $\overline{SSB}_{y-2,y-1,y} > SSB_{30\%}$ = Not Overfished $\overline{SSB}_{y-2,y-1,y} \leq SSB_{30\%}$ = Overfished	Biomass Status	SS

**Table 54. Configuration details for fishing fleets in the SS northern stock model.**

<u>Fishing Fleet Name</u>	<u>Years</u>	<u>Discard Mortality</u>	<u>Catch Error Type</u>	<u>Selectivity</u>	<u>Retention Periods</u>	<u>Composition Error Type</u>
North_Commercial_GNBS	1981-2022	1	Lognormal	Double Normal Length and Derived Age	1981-1991, 1992-1997, 1998-2022	Multinomial
North_Commercial_Other	1981-2022	n/a	Lognormal	Double Normal Length and Derived Age	1981-2022*	Multinomial
North_Recreational	1981-2022	0.08	Lognormal	Double Normal Length and Derived Age	1981-1991, 1992-1997, 1998-2022	Multinomial

\*The commercial other fleet is a selectivity block, not a retention block, due to a lack of discard information.

**Table 55. Configuration details for monitoring surveys in the SS northern stock model.**

<u>Survey Name</u>	<u>Years</u>	<u>Timing</u>	<u>Catch Error Type</u>	<u>Selectivity</u>	<u>Composition Error Type</u>
NC_BagSeine	1991-1995, 1997-2022	October 1	Lognormal	Age-0 Recruitment (SS special survey type 33)	NA
NC_GillNet	2003-2019, 2021-2022	October 1	Lognormal	Double Normal Length and Derived Age	Multinomial
NC_Longline	2007-2019, 2021-2022	September 1	Lognormal	Logistic Age	Multinomial

**Table 56. Retention block details for fishing fleets in the SS northern stock model.**

<u>Fleet</u>	<u>Years</u>	<u>Parameters</u>	<u>Regulation Change</u>
North_Commercial_GNBS	1992-1997	Inflection, Width, Asymptote, Dome Inflection, Dome Width	Minimum size increase, Maximum size decrease
North_Commercial_GNBS	1998-2022	Asymptote, Dome Inflection, Dome Width	Maximum size decrease, Commercial trip limit implemented
North_Recreational	1992-1997	Inflection, Width, Asymptote, Dome Inflection, Dome Width	Minimum size increase, Maximum size decrease
North_Recreational	1998-2022	Inflection, Width, Asymptote, Dome Inflection, Dome Width	Maximum size decrease, Bag limit decrease

**Table 57. Configuration details for fishing fleets in the SS southern stock model.**

<u>Fishing Fleet Name</u>	<u>Years</u>	<u>Discard Mortality</u>	<u>Catch Error Type</u>	<u>Selectivity</u>	<u>Retention Periods</u>	<u>Composition Error Type</u>
SC_Recreational	1981-2022	0.08	Lognormal	Double Normal Length and Derived Age	1981-1989, 1990-1992, 1993-2000, 2001-2006, 2007-2017, 2018--2022	Multinomial
GA_Recreational	1981-2022	0.08	Lognormal	Double Normal Length and Derived Age	1981-1985, 1986-1992, 1993-2001, 2002-2022	Multinomial
FL_Recreational	1981-2022	0.08	Lognormal	Double Normal Length and Derived Age	1981-1984, 1985-1988, 1989-2022	Multinomial

**Table 58. Configuration details for monitoring surveys in the SS southern stock model.**

<u>Survey Name</u>	<u>Years</u>	<u>Timing</u>	<u>Catch Error Type</u>	<u>Selectivity</u>	<u>Composition Error Type</u>
FL_21.3_HaulSeine	2001-2021	October 15	Lognormal	Age-0 Recruitment (SS special survey type 33)	NA
SC_Rotenone	1986-1993	October 15	Lognormal	Age-0 Recruitment (SS special survey type 33)	NA
GA_GillNet	2002-2022	July 15	Lognormal	Age-0 Only	NA
SC_StopNet	1987-1993	July 1	Lognormal	Double Normal Age	Multinomial
SC_Trammel	1991-2022	July 1	Lognormal	Double Normal Age	Multinomial
FL_183_HaulSeine	2001-2021	July 1	Lognormal	Double Normal Age	Multinomial
SC_Longline_contemporary	2007-2022	October 15	Lognormal	Double Normal Length and Derived Age	Multinomial



**Table 59. Retention block details for fishing fleets in the SS southern stock model.**

<u>Fleet</u>	<u>Years</u>	<u>Parameters</u>	<u>Regulation Change</u>
SC_Recreational	1990-1992	Inflection, Width, Asymptote	Minimum size season to full year
SC_Recreational	1993-2000	Dome Inflection, Dome Width	Maximum size
SC_Recreational	2001-2006	Inflection, Width, Asymptote, Dome Inflection, Dome Width	Minimum size increase, Maximum size decrease, Bag limit decrease
SC_Recreational	2007-2017	Asymptote	Bag limit increase
SC_Recreational	2018-2022	Asymptote	Bag limit decrease, Vessel limit
GA_Recreational	1986-1992	Inflection, Width, Dome Inflection, Dome Width	Minimum size, Bag limit for fish >32"
GA_Recreational	1993-2001	Dome Inflection, Dome Width	Maximum size
GA_Recreational	2002-2022	Dome Inflection, Dome Width	Maximum size decrease
FL_Recreational	1985-1988	Inflection, Width	Minimum size increase
FL_Recreational	1989-2022	Asymptote, Dome Inflection, Dome Width	Maximum size, Bag limit

**Table 60. Life history and recruitment parameters for the northern stock SS estimated selectivity model.**

Parameter	Type	Final Value	SE	Lower Bound	Upper Bound	Prior Type	Prior Mean	Prior sd
NatM_Lorenzoz_Fem_GP_1	Fixed	0.1580	NA	NA	NA	NA	NA	NA
L_at_Amin_Fem_GP_1	Fixed	6.0000	NA	NA	NA	NA	NA	NA
L_at_Amax_Fem_GP_1	Estimated	131.9730	1.0654	100	150	Sym Beta	NA	0.158
VonBert_K_young_Fem_GP_1	Estimated	0.2860	0.0031	0.1	0.9	NA	NA	NA
Age_K_mult_Fem_GP_1_a_2	Estimated	0.9584	0.0184	0.1	1.5	NA	NA	NA
Age_K_mult_Fem_GP_1_a_6	Estimated	0.1550	0.0115	0.01	1	NA	NA	NA
CV_young_Fem_GP_1	Estimated	0.2989	0.0025	0.01	0.4	NA	NA	NA
CV_old_Fem_GP_1	Estimated	0.0321	0.0024	0.01	0.2	NA	NA	NA
Wtlen_1_Fem_GP_1	Fixed	0.0000	NA	NA	NA	NA	NA	NA
Wtlen_2_Fem_GP_1	Fixed	2.9861	NA	NA	NA	NA	NA	NA
Mat50%_Fem_GP_1	Fixed	3.5000	NA	NA	NA	NA	NA	NA
Mat_slope_Fem_GP_1	Fixed	-4.2800	NA	NA	NA	NA	NA	NA
SR_LN(R0)	Estimated	7.9141	0.0792	3	11	Sym Beta	NA	0.5
SR_BH_steep	Fixed	0.9900	NA	NA	NA	NA	NA	NA
SR_sigmaR	Fixed	0.6953	NA	NA	NA	NA	NA	NA
Early_InitAge_11	Deviation	1.4753	0.2558	-5	5	NA	NA	NA
Early_InitAge_10	Deviation	2.2592	0.1725	-5	5	NA	NA	NA
Early_InitAge_9	Deviation	2.4621	0.1490	-5	5	NA	NA	NA
Early_InitAge_8	Deviation	3.5557	0.0983	-5	5	NA	NA	NA
Early_InitAge_7	Deviation	2.4917	0.1305	-5	5	NA	NA	NA
Early_InitAge_6	Deviation	1.0123	0.2183	-5	5	NA	NA	NA
Early_InitAge_5	Deviation	-0.2788	0.3407	-5	5	NA	NA	NA
Early_InitAge_4	Deviation	-0.3560	0.3295	-5	5	NA	NA	NA
Early_InitAge_3	Deviation	2.2446	0.1141	-5	5	NA	NA	NA
Early_InitAge_2	Deviation	0.8456	0.1773	-5	5	NA	NA	NA
Early_InitAge_1	Deviation	1.0973	0.1470	-5	5	NA	NA	NA
Main_RecrDev_1981	Deviation	0.3510	0.1817	-5	5	NA	NA	NA
Main_RecrDev_1982	Deviation	0.6231	0.1502	-5	5	NA	NA	NA
Main_RecrDev_1983	Deviation	0.2586	0.1515	-5	5	NA	NA	NA
Main_RecrDev_1984	Deviation	-0.4190	0.1843	-5	5	NA	NA	NA
Main_RecrDev_1985	Deviation	0.6424	0.1016	-5	5	NA	NA	NA
Main_RecrDev_1986	Deviation	0.2376	0.1074	-5	5	NA	NA	NA
Main_RecrDev_1987	Deviation	0.4486	0.0874	-5	5	NA	NA	NA
Main_RecrDev_1988	Deviation	-0.7714	0.1266	-5	5	NA	NA	NA
Main_RecrDev_1989	Deviation	-0.2009	0.1107	-5	5	NA	NA	NA
Main_RecrDev_1990	Deviation	0.6357	0.0904	-5	5	NA	NA	NA
Main_RecrDev_1991	Deviation	0.4382	0.0869	-5	5	NA	NA	NA
Main_RecrDev_1992	Deviation	-0.0965	0.0942	-5	5	NA	NA	NA
Main_RecrDev_1993	Deviation	0.4952	0.0833	-5	5	NA	NA	NA
Main_RecrDev_1994	Deviation	-0.1661	0.0910	-5	5	NA	NA	NA
Main_RecrDev_1995	Deviation	-0.3266	0.0989	-5	5	NA	NA	NA
Main_RecrDev_1996	Deviation	0.8758	0.0815	-5	5	NA	NA	NA
Main_RecrDev_1997	Deviation	0.6002	0.0727	-5	5	NA	NA	NA
Main_RecrDev_1998	Deviation	0.1446	0.0711	-5	5	NA	NA	NA
Main_RecrDev_1999	Deviation	-1.0254	0.0829	-5	5	NA	NA	NA
Main_RecrDev_2000	Deviation	-0.7491	0.0693	-5	5	NA	NA	NA
Main_RecrDev_2001	Deviation	-0.1437	0.0524	-5	5	NA	NA	NA
Main_RecrDev_2002	Deviation	-0.6962	0.0605	-5	5	NA	NA	NA
Main_RecrDev_2003	Deviation	0.1527	0.0530	-5	5	NA	NA	NA
Main_RecrDev_2004	Deviation	0.0930	0.0517	-5	5	NA	NA	NA
Main_RecrDev_2005	Deviation	0.7606	0.0445	-5	5	NA	NA	NA
Main_RecrDev_2006	Deviation	-0.2239	0.0549	-5	5	NA	NA	NA
Main_RecrDev_2007	Deviation	0.6598	0.0449	-5	5	NA	NA	NA
Main_RecrDev_2008	Deviation	-0.3695	0.0583	-5	5	NA	NA	NA
Main_RecrDev_2009	Deviation	-0.6321	0.0582	-5	5	NA	NA	NA
Main_RecrDev_2010	Deviation	-1.0812	0.0681	-5	5	NA	NA	NA
Main_RecrDev_2011	Deviation	1.6562	0.0448	-5	5	NA	NA	NA
Main_RecrDev_2012	Deviation	-0.1859	0.0639	-5	5	NA	NA	NA
Main_RecrDev_2013	Deviation	-0.5870	0.0599	-5	5	NA	NA	NA
Main_RecrDev_2014	Deviation	-0.6316	0.0644	-5	5	NA	NA	NA
Main_RecrDev_2015	Deviation	0.8131	0.0517	-5	5	NA	NA	NA
Main_RecrDev_2016	Deviation	-0.4527	0.0629	-5	5	NA	NA	NA
Main_RecrDev_2017	Deviation	-0.9489	0.0761	-5	5	NA	NA	NA
Main_RecrDev_2018	Deviation	1.2281	0.0572	-5	5	NA	NA	NA
Main_RecrDev_2019	Deviation	0.9256	0.0601	-5	5	NA	NA	NA
Main_RecrDev_2020	Deviation	-0.5437	0.0736	-5	5	NA	NA	NA
Main_RecrDev_2021	Deviation	-0.9532	0.0865	-5	5	NA	NA	NA
Main_RecrDev_2022	Deviation	-0.8356	0.2117	-5	5	NA	NA	NA
ForeRecr_2023	Deviation	0.0000	0.6953	-5	5	NA	NA	NA

**Table 61. Fishing fleet initial fishing mortality, selectivity, retention, and discard mortality parameters for the northern stock SS estimated selectivity model.**

Parameter	Type	Final Value	SE	Lower Bound	Upper Bound	Prior Type	Prior Mean	Prior sd
InitF_seas_1_flt_1North_Commercial_GNBS	Estimated	0.0039	0.0046	0	0.8	Sym Beta	NA	0.75
InitF_seas_1_flt_2North_Commercial_Other	Estimated	0.0000	0.0000	0	1	NA	NA	NA
InitF_seas_1_flt_3North_Recreational	Estimated	0.0081	0.0095	0	1	Sym Beta	NA	0.75
Size_DblN_peak_North_Commercial_GNBS(1)	Estimated	36.2269	0.3015	15	60	NA	NA	NA
Size_DblN_top_logit_North_Commercial_GNBS(1)	Estimated	-1.2640	0.0188	-6	2	NA	NA	NA
Size_DblN_ascend_se_North_Commercial_GNBS(1)	Estimated	3.4909	0.0680	0.01	8	NA	NA	NA
Size_DblN_descend_se_North_Commercial_GNBS(1)	Estimated	3.4728	0.0847	2	8	NA	NA	NA
Size_DblN_start_logit_North_Commercial_GNBS(1)	Fixed	-999.0000	NA	NA	NA	NA	NA	NA
Size_DblN_end_logit_North_Commercial_GNBS(1)	Estimated	-9.2334	0.4609	-15	-1	NA	NA	NA
Retain_L_infl_North_Commercial_GNBS(1)	Estimated	32.2250	1.5850	20	60	NA	NA	NA
Retain_L_width_North_Commercial_GNBS(1)	Estimated	0.3181	0.7495	0.01	5	NA	NA	NA
Retain_L_asymptote_logit_North_Commercial_GNBS(1)	Estimated	1.3318	0.1522	-5	8	NA	NA	NA
Retain_L_dome_infl_North_Commercial_GNBS(1)	Estimated	89.9933	0.2166	60	90	NA	NA	NA
Retain_L_dome_width_North_Commercial_GNBS(1)	Estimated	4.9989	0.0380	0.01	5	NA	NA	NA
DiscMort_L_level_old_North_Commercial_GNBS(1)	Fixed	1.0000	NA	NA	NA	NA	NA	NA
Size_DblN_peak_North_Commercial_Other(2)	Estimated	62.3001	0.7034	30	65	NA	NA	NA
Size_DblN_top_logit_North_Commercial_Other(2)	Estimated	-12.5151	45.1034	-15	0	NA	NA	NA
Size_DblN_ascend_se_North_Commercial_Other(2)	Estimated	5.4824	0.0918	0.01	8	NA	NA	NA
Size_DblN_descend_se_North_Commercial_Other(2)	Estimated	3.8250	0.2015	2	6	NA	NA	NA
Size_DblN_start_logit_North_Commercial_Other(2)	Fixed	-11.9000	NA	NA	NA	NA	NA	NA
Size_DblN_end_logit_North_Commercial_Other(2)	Estimated	-7.3870	0.4473	-15	-2	NA	NA	NA
Size_DblN_peak_North_Recreational(3)	Estimated	32.8010	0.2163	20	100	NA	NA	NA
Size_DblN_top_logit_North_Recreational(3)	Estimated	-5.0000	0.0000	-5	4	NA	NA	NA
Size_DblN_ascend_se_North_Recreational(3)	Estimated	3.3809	0.0697	0.01	10	NA	NA	NA
Size_DblN_descend_se_North_Recreational(3)	Estimated	6.2505	0.0227	0.01	8	NA	NA	NA
Size_DblN_start_logit_North_Recreational(3)	Estimated	-5.1164	0.2109	-15	8	NA	NA	NA
Size_DblN_end_logit_North_Recreational(3)	Estimated	-4.5648	0.0643	-15	5	NA	NA	NA
Retain_L_infl_North_Recreational(3)	Estimated	30.2293	1.0168	15	60	NA	NA	NA
Retain_L_width_North_Recreational(3)	Estimated	3.1397	0.6104	0.01	8	NA	NA	NA
Retain_L_asymptote_logit_North_Recreational(3)	Estimated	12.4510	110.6340	-1	20	NA	NA	NA
Retain_L_dome_infl_North_Recreational(3)	Estimated	72.9680	4.0785	60	100	NA	NA	NA
Retain_L_dome_width_North_Recreational(3)	Estimated	14.9843	0.4831	0.01	15	NA	NA	NA
DiscMort_L_level_old_North_Recreational(3)	Fixed	0.0800	NA	NA	NA	NA	NA	NA
Retain_L_infl_North_Commercial_GNBS(1)_BLK2repl_1992	Estimated	44.4620	0.1376	30	60	NA	NA	NA
Retain_L_width_North_Commercial_GNBS(1)_BLK2repl_1992	Estimated	0.8326	0.0588	0.01	3	NA	NA	NA
Retain_L_asymptote_logit_North_Commercial_GNBS(1)_BLK1repl_1992	Estimated	4.9853	0.4631	0	5	NA	NA	NA
Retain_L_asymptote_logit_North_Commercial_GNBS(1)_BLK1repl_1998	Estimated	2.0181	0.0566	0	5	NA	NA	NA
Retain_L_dome_infl_North_Commercial_GNBS(1)_BLK1repl_1992	Estimated	89.9808	0.6113	60	90	NA	NA	NA
Retain_L_dome_infl_North_Commercial_GNBS(1)_BLK1repl_1998	Estimated	75.4998	1.1353	60	90	NA	NA	NA
Retain_L_dome_width_North_Commercial_GNBS(1)_BLK1repl_1992	Estimated	4.9887	0.3592	0.01	5	NA	NA	NA
Retain_L_dome_width_North_Commercial_GNBS(1)_BLK1repl_1998	Estimated	2.4837	0.5109	0.01	5	NA	NA	NA
Retain_L_infl_North_Recreational(3)_BLK1repl_1992	Estimated	53.0134	0.7903	30	60	NA	NA	NA
Retain_L_infl_North_Recreational(3)_BLK1repl_1998	Estimated	49.2112	0.4074	30	60	NA	NA	NA
Retain_L_width_North_Recreational(3)_BLK1repl_1992	Estimated	6.0000	0.0047	0.01	6	NA	NA	NA
Retain_L_width_North_Recreational(3)_BLK1repl_1998	Estimated	3.2593	0.1567	0.01	6	NA	NA	NA
Retain_L_asymptote_logit_North_Recreational(3)_BLK1repl_1992	Estimated	1.9916	0.2659	-1	2	NA	NA	NA
Retain_L_asymptote_logit_North_Recreational(3)_BLK1repl_1998	Estimated	0.1640	0.1011	-1	2	NA	NA	NA
Retain_L_dome_infl_North_Recreational(3)_BLK1repl_1992	Estimated	85.7027	3.7643	60	90	NA	NA	NA
Retain_L_dome_infl_North_Recreational(3)_BLK1repl_1998	Estimated	71.7439	0.7245	60	90	NA	NA	NA
Retain_L_dome_width_North_Recreational(3)_BLK1repl_1992	Estimated	9.1637	1.5071	0.01	10	NA	NA	NA
Retain_L_dome_width_North_Recreational(3)_BLK1repl_1998	Estimated	4.2413	0.5477	0.01	10	NA	NA	NA

**Table 62. Survey catchability coefficient and selectivity parameters for the northern stock SS estimated selectivity model.**

Parameter	Type	Final Value	SE	Lower Bound	Upper Bound
LnQ_base_NC_BagSeine(4)	Derived	-7.8853	NA	NA	NA
LnQ_base_NC_GillNet(5)	Derived	-7.3057	NA	NA	NA
LnQ_base_NC_Longline(6)	Derived	-8.6809	NA	NA	NA
Size_DblN_peak_NC_GillNet(5)	Estimated	39.4060	0.2827	20	50
Size_DblN_top_logit_NC_GillNet(5)	Estimated	-9.9446	1.7092	-10	-1
Size_DblN_ascend_se_NC_GillNet(5)	Estimated	4.4289	0.0595	1	8
Size_DblN_descend_se_NC_GillNet(5)	Estimated	5.8338	0.0263	4	8
Size_DblN_start_logit_NC_GillNet(5)	Estimated	-8.2439	0.5586	-25	-5
Size_DblN_end_logit_NC_GillNet(5)	Estimated	-5.9727	0.0793	-8	-2
Age_inflection_NC_Longline(6)	Estimated	19.5342	1.1525	3	62
Age_95%width_NC_Longline(6)	Estimated	12.3119	0.8933	5	40

**Table 63. Jitter analysis results for the northern stock SS estimated selectivity model. The -LL column shows the change in total negative log-likelihood relative to the base model.**

<b>-LL</b>	<b>Δ -LL</b>	<b>Frequency</b>	<b>Converged?</b>
18,607.0	-0.3	6	Yes
18,607.3	0.0	19	Yes
18,698.8	91.5	1	No
18,762.3	155.0	1	No
18,786.7	179.4	1	No
18,788.0	180.7	1	No
18,870.8	263.5	1	No
19,026.0	418.7	1	No
19,058.7	451.4	1	No
19,275.7	668.4	1	No
19,400.4	793.1	1	No
19,697.3	1,090.0	1	No
19,753.1	1,145.8	1	No
20,680.8	2,073.5	1	No
20,701.9	2,094.6	1	No
20,747.1	2,139.8	1	No
20,966.5	2,359.2	1	No
21,319.9	2,712.6	1	No
21,494.9	2,887.6	1	No
21,654.2	3,046.9	1	No
21,900.7	3,293.4	1	No
21,949.7	3,342.4	1	No
21,970.5	3,363.2	1	No
22,342.7	3,735.4	1	No
27,696.3	9,089.0	1	No
33,542.7	14,935.4	1	No
57,944.2	39,336.9	1	No



**Table 65. Female spawning stock biomass estimates for the northern stock SS estimated selectivity model. 95% confidence intervals are based on asymptotic standard errors.**

Year	Annual SSB (metric tons)			Annual Relative SSB			Three-Year Average Relative SSB
	LCI	Estimate	UCI	LCI	Estimate	UCI	
Unfished	33,944	40,162	46,380	NA	NA	NA	NA
Target	13,544	16,004	18,463	NA	NA	NA	NA
Threshold	10,137	11,977	13,818	NA	1.000	NA	1.000
1981	122,167	163,424	204,681	11.699	13.564	15.429	NA
1982	122,986	164,490	205,994	11.795	13.652	15.510	NA
1983	120,730	161,474	202,218	11.587	13.402	15.217	13.539
1984	118,234	158,134	198,034	11.355	13.125	14.894	13.393
1985	112,734	150,791	188,848	10.834	12.515	14.197	13.014
1986	107,364	143,603	179,842	10.325	11.919	13.512	12.520
1987	101,395	135,629	169,863	9.757	11.257	12.756	11.897
1988	95,330	127,510	159,690	9.178	10.583	11.988	11.253
1989	90,160	120,598	151,036	8.687	10.009	11.332	10.616
1990	85,151	113,903	142,655	8.210	9.454	10.697	10.015
1991	80,596	107,793	134,990	7.777	8.947	10.117	9.470
1992	75,603	101,098	126,593	7.298	8.391	9.484	8.930
1993	71,139	95,093	119,047	6.871	7.892	8.914	8.410
1994	67,893	90,680	113,466	6.565	7.526	8.487	7.937
1995	65,148	86,892	108,637	6.307	7.212	8.117	7.543
1996	62,192	82,840	103,488	6.026	6.876	7.725	7.205
1997	59,749	79,433	99,116	5.796	6.593	7.390	6.893
1998	56,905	75,525	94,146	5.524	6.268	7.013	6.579
1999	54,180	71,787	89,393	5.263	5.958	6.653	6.273
2000	52,818	69,814	86,810	5.138	5.794	6.451	6.007
2001	51,492	67,915	84,338	5.015	5.637	6.258	5.796
2002	49,690	65,433	81,176	4.845	5.431	6.017	5.621
2003	46,915	61,744	76,573	4.577	5.125	5.672	5.397
2004	44,047	57,936	71,825	4.299	4.809	5.318	5.121
2005	41,504	54,551	67,597	4.054	4.528	5.001	4.820
2006	39,168	51,429	63,691	3.828	4.269	4.709	4.535
2007	37,626	49,290	60,954	3.680	4.091	4.502	4.296
2008	36,382	47,528	58,674	3.561	3.945	4.328	4.101
2009	36,087	46,939	57,791	3.535	3.896	4.256	3.977
2010	35,071	45,491	55,911	3.438	3.776	4.113	3.872
2011	34,574	44,700	54,826	3.392	3.710	4.028	3.794
2012	33,083	42,706	52,329	3.247	3.545	3.842	3.677
2013	31,433	40,518	49,603	3.086	3.363	3.640	3.539
2014	29,730	38,279	46,829	2.920	3.177	3.435	3.361
2015	31,276	40,058	48,840	3.074	3.325	3.575	3.288
2016	31,062	39,706	48,350	3.053	3.295	3.538	3.266
2017	30,241	38,611	46,982	2.971	3.205	3.438	3.275
2018	28,619	36,529	44,439	2.812	3.032	3.251	3.177
2019	27,869	35,534	43,200	2.739	2.949	3.160	3.062
2020	26,700	34,023	41,347	2.623	2.824	3.024	2.935
2021	25,566	32,545	39,524	2.511	2.701	2.891	2.825
2022	26,383	33,397	40,411	2.587	2.772	2.957	2.766

**Table 66. Age-2 fishing mortality (F) and spawning potential ratio (SPR) estimates for the northern stock SS estimated selectivity model. 95% confidence intervals are based on asymptotic standard errors.**

Year	Age-2 F			Annual SPR			Three-Year Average SPR
	LCI	Estimate	UCI	LCI	Estimate	UCI	
Target	0.267	0.274	0.281	NA	0.400	NA	0.400
Threshold	0.350	0.360	0.369	NA	0.300	NA	0.300
1981	0.010	0.015	0.019	0.969	0.976	0.984	NA
1982	0.021	0.031	0.041	0.935	0.950	0.966	NA
1983	0.040	0.057	0.074	0.868	0.898	0.928	0.941
1984	0.074	0.104	0.134	0.634	0.710	0.786	0.853
1985	0.096	0.134	0.173	0.791	0.837	0.883	0.815
1986	0.115	0.160	0.205	0.710	0.767	0.825	0.771
1987	0.105	0.144	0.183	0.734	0.786	0.837	0.797
1988	0.139	0.187	0.236	0.576	0.650	0.723	0.734
1989	0.175	0.238	0.302	0.507	0.595	0.683	0.677
1990	0.171	0.235	0.298	0.778	0.825	0.872	0.690
1991	0.130	0.179	0.228	0.845	0.877	0.909	0.766
1992	0.075	0.102	0.130	0.887	0.910	0.933	0.871
1993	0.084	0.113	0.142	0.779	0.820	0.861	0.869
1994	0.083	0.110	0.138	0.896	0.916	0.936	0.882
1995	0.115	0.151	0.186	0.745	0.791	0.836	0.842
1996	0.098	0.128	0.159	0.859	0.885	0.912	0.864
1997	0.105	0.137	0.168	0.866	0.891	0.917	0.856
1998	0.092	0.119	0.146	0.800	0.835	0.870	0.871
1999	0.135	0.173	0.212	0.680	0.731	0.782	0.819
2000	0.186	0.238	0.291	0.647	0.703	0.759	0.756
2001	0.224	0.284	0.345	0.654	0.708	0.761	0.714
2002	0.291	0.367	0.443	0.466	0.538	0.610	0.650
2003	0.276	0.349	0.423	0.698	0.748	0.797	0.665
2004	0.227	0.288	0.349	0.861	0.884	0.906	0.723
2005	0.151	0.189	0.228	0.731	0.771	0.810	0.801
2006	0.137	0.169	0.201	0.771	0.803	0.836	0.819
2007	0.196	0.239	0.283	0.640	0.688	0.735	0.754
2008	0.196	0.239	0.281	0.735	0.771	0.806	0.754
2009	0.269	0.326	0.383	0.531	0.588	0.644	0.682
2010	0.308	0.374	0.440	0.517	0.576	0.635	0.645
2011	0.561	0.629	0.697	0.285	0.306	0.328	0.490
2012	0.491	0.544	0.596	0.766	0.797	0.828	0.560
2013	0.529	0.588	0.648	0.426	0.488	0.550	0.530
2014	0.333	0.405	0.477	0.536	0.595	0.654	0.627
2015	0.383	0.467	0.550	0.583	0.637	0.692	0.573
2016	0.362	0.435	0.509	0.492	0.546	0.599	0.593
2017	0.436	0.525	0.614	0.364	0.430	0.497	0.538
2018	0.517	0.631	0.745	0.359	0.434	0.509	0.470
2019	0.451	0.551	0.652	0.690	0.729	0.769	0.531
2020	0.371	0.449	0.526	0.576	0.623	0.669	0.595
2021	0.364	0.434	0.504	0.396	0.456	0.517	0.603
2022	0.615	0.687	0.759	0.273	0.295	0.317	0.458

**Table 67. Life history and recruitment parameters for the southern stock SS base model.**

Parameter	Type	Final Value	SE	Lower Bound	Upper Bound
NatM_Lorenzen_Fem_GP_1	Fixed	0.233	NA	NA	NA
L_at_Amin_Fem_GP_1	Estimated	21.3248	0.170502	6	25
L_at_Amax_Fem_GP_1	Estimated	107.465	0.886232	90	130
VonBert_K_young_Fem_GP_1	Estimated	0.42621	0.009498	0.1	0.7
Age_K_mult_Fem_GP_1_a_1	Estimated	0.522782	0.007614	0.01	1
Age_K_mult_Fem_GP_1_a_6	Estimated	0.258823	0.017846	0.01	1
CV_young_Fem_GP_1	Estimated	0.186205	0.00228	0.05	0.4
CV_old_Fem_GP_1	Estimated	0.0213179	0.002133	0.01	0.3
Wtlen_1_Fem_GP_1	Fixed	0.0000136	NA	NA	NA
Wtlen_2_Fem_GP_1	Fixed	2.91963	NA	NA	NA
Mat50%_Fem_GP_1	Fixed	4.2	NA	NA	NA
Mat_slope_Fem_GP_1	Fixed	-1.546	NA	NA	NA
SR_LN(R0)	Estimated	8.66822	0.07429	6	13
SR_BH_steep	Fixed	0.99	NA	NA	NA
SR_sigmaR	Fixed	0.366875	NA	NA	NA
Early_InitAge_11	Deviation	-0.045084	0.339015	-5	5
Early_InitAge_10	Deviation	0.051318	0.334174	-5	5
Early_InitAge_9	Deviation	0.0322925	0.331883	-5	5
Early_InitAge_8	Deviation	0.197758	0.323304	-5	5
Early_InitAge_7	Deviation	0.477961	0.309126	-5	5
Early_InitAge_6	Deviation	-0.255133	0.329724	-5	5
Early_InitAge_5	Deviation	0.0953901	0.310701	-5	5
Early_InitAge_4	Deviation	-0.042687	0.299169	-5	5
Early_InitAge_3	Deviation	-0.049124	0.268567	-5	5
Early_InitAge_2	Deviation	-0.544779	0.241777	-5	5
Early_InitAge_1	Deviation	-1.05428	0.219041	-5	5
Main_RecrDev_1981	Deviation	-0.417774	0.192702	-5	5
Main_RecrDev_1982	Deviation	-0.141382	0.165132	-5	5
Main_RecrDev_1983	Deviation	-0.114787	0.138962	-5	5
Main_RecrDev_1984	Deviation	0.157352	0.093696	-5	5
Main_RecrDev_1985	Deviation	-0.179478	0.105397	-5	5
Main_RecrDev_1986	Deviation	0.289561	0.095677	-5	5
Main_RecrDev_1987	Deviation	0.160027	0.097664	-5	5
Main_RecrDev_1988	Deviation	-0.470431	0.111385	-5	5
Main_RecrDev_1989	Deviation	0.0413507	0.083432	-5	5
Main_RecrDev_1990	Deviation	0.1814	0.070482	-5	5
Main_RecrDev_1991	Deviation	0.300989	0.060107	-5	5
Main_RecrDev_1992	Deviation	0.0491724	0.058537	-5	5
Main_RecrDev_1993	Deviation	-0.084244	0.055002	-5	5
Main_RecrDev_1994	Deviation	0.304726	0.047753	-5	5
Main_RecrDev_1995	Deviation	-0.476094	0.059042	-5	5
Main_RecrDev_1996	Deviation	-0.01229	0.045678	-5	5
Main_RecrDev_1997	Deviation	-0.267328	0.047237	-5	5
Main_RecrDev_1998	Deviation	-0.211435	0.045937	-5	5
Main_RecrDev_1999	Deviation	-0.632201	0.054325	-5	5
Main_RecrDev_2000	Deviation	0.471304	0.038974	-5	5
Main_RecrDev_2001	Deviation	0.428896	0.039785	-5	5
Main_RecrDev_2002	Deviation	0.515025	0.038351	-5	5
Main_RecrDev_2003	Deviation	0.165893	0.042291	-5	5
Main_RecrDev_2004	Deviation	-0.150181	0.04437	-5	5
Main_RecrDev_2005	Deviation	-0.534024	0.050133	-5	5
Main_RecrDev_2006	Deviation	-0.043205	0.04275	-5	5
Main_RecrDev_2007	Deviation	0.152117	0.041116	-5	5
Main_RecrDev_2008	Deviation	0.241746	0.042537	-5	5
Main_RecrDev_2009	Deviation	0.407454	0.040973	-5	5
Main_RecrDev_2010	Deviation	0.0888281	0.043836	-5	5
Main_RecrDev_2011	Deviation	-0.131647	0.050604	-5	5
Main_RecrDev_2012	Deviation	-0.157429	0.053366	-5	5
Main_RecrDev_2013	Deviation	-0.222322	0.056716	-5	5
Main_RecrDev_2014	Deviation	-0.483486	0.061265	-5	5
Main_RecrDev_2015	Deviation	0.0804919	0.053775	-5	5
Main_RecrDev_2016	Deviation	0.115634	0.054775	-5	5
Main_RecrDev_2017	Deviation	-0.002638	0.055375	-5	5
Main_RecrDev_2018	Deviation	-0.063348	0.055534	-5	5
Main_RecrDev_2019	Deviation	-0.303317	0.061064	-5	5
Main_RecrDev_2020	Deviation	0.198059	0.056487	-5	5
Main_RecrDev_2021	Deviation	0.0651627	0.074081	-5	5
Main_RecrDev_2022	Deviation	0.683855	0.10993	-5	5
ForeRecr_2023	Deviation	0	0.366875	-5	5



**Table 68. Fishing mortality parameter estimates for the southern stock SS base model. SC\_Recreational, GA\_Recreational, and FL\_Recreational are fleets 1, 2, and 3, respectively.**

Parameter	Estimate	SE	Parameter	Estimate	SE
F fleet 1 YR 1981 s 1	0.058	0.025	F fleet 2 YR 2002 s 1	0.087	0.015
F fleet 1 YR 1982 s 1	0.183	0.037	F fleet 2 YR 2003 s 1	0.072	0.012
F fleet 1 YR 1983 s 1	0.058	0.035	F fleet 2 YR 2004 s 1	0.071	0.013
F fleet 1 YR 1984 s 1	0.134	0.049	F fleet 2 YR 2005 s 1	0.112	0.021
F fleet 1 YR 1985 s 1	0.300	0.069	F fleet 2 YR 2006 s 1	0.082	0.016
F fleet 1 YR 1986 s 1	0.080	0.020	F fleet 2 YR 2007 s 1	0.144	0.030
F fleet 1 YR 1987 s 1	0.147	0.033	F fleet 2 YR 2008 s 1	0.100	0.018
F fleet 1 YR 1988 s 1	0.080	0.021	F fleet 2 YR 2009 s 1	0.103	0.017
F fleet 1 YR 1989 s 1	0.066	0.016	F fleet 2 YR 2010 s 1	0.168	0.028
F fleet 1 YR 1990 s 1	0.078	0.025	F fleet 2 YR 2011 s 1	0.071	0.013
F fleet 1 YR 1991 s 1	0.068	0.020	F fleet 2 YR 2012 s 1	0.074	0.016
F fleet 1 YR 1992 s 1	0.048	0.012	F fleet 2 YR 2013 s 1	0.155	0.025
F fleet 1 YR 1993 s 1	0.079	0.021	F fleet 2 YR 2014 s 1	0.230	0.038
F fleet 1 YR 1994 s 1	0.080	0.018	F fleet 2 YR 2015 s 1	0.193	0.034
F fleet 1 YR 1995 s 1	0.138	0.038	F fleet 2 YR 2016 s 1	0.288	0.047
F fleet 1 YR 1996 s 1	0.185	0.053	F fleet 2 YR 2017 s 1	0.327	0.052
F fleet 1 YR 1997 s 1	0.065	0.013	F fleet 2 YR 2018 s 1	0.413	0.068
F fleet 1 YR 1998 s 1	0.076	0.014	F fleet 2 YR 2019 s 1	0.266	0.060
F fleet 1 YR 1999 s 1	0.068	0.015	F fleet 2 YR 2020 s 1	0.187	0.030
F fleet 1 YR 2000 s 1	0.044	0.009	F fleet 2 YR 2021 s 1	0.270	0.048
F fleet 1 YR 2001 s 1	0.079	0.015	F fleet 2 YR 2022 s 1	0.444	0.073
F fleet 1 YR 2002 s 1	0.082	0.016	F fleet 3 YR 1981 s 1	0.186	0.069
F fleet 1 YR 2003 s 1	0.106	0.021	F fleet 3 YR 1982 s 1	0.780	0.304
F fleet 1 YR 2004 s 1	0.089	0.016	F fleet 3 YR 1983 s 1	1.280	0.272
F fleet 1 YR 2005 s 1	0.153	0.027	F fleet 3 YR 1984 s 1	0.734	0.175
F fleet 1 YR 2006 s 1	0.185	0.035	F fleet 3 YR 1985 s 1	0.370	0.099
F fleet 1 YR 2007 s 1	0.142	0.027	F fleet 3 YR 1986 s 1	0.091	0.024
F fleet 1 YR 2008 s 1	0.211	0.040	F fleet 3 YR 1987 s 1	0.144	0.044
F fleet 1 YR 2009 s 1	0.216	0.034	F fleet 3 YR 1988 s 1	0.053	0.014
F fleet 1 YR 2010 s 1	0.336	0.053	F fleet 3 YR 1989 s 1	0.145	0.042
F fleet 1 YR 2011 s 1	0.187	0.029	F fleet 3 YR 1990 s 1	0.125	0.039
F fleet 1 YR 2012 s 1	0.254	0.037	F fleet 3 YR 1991 s 1	0.325	0.089
F fleet 1 YR 2013 s 1	0.251	0.032	F fleet 3 YR 1992 s 1	0.198	0.037
F fleet 1 YR 2014 s 1	0.398	0.067	F fleet 3 YR 1993 s 1	0.244	0.044
F fleet 1 YR 2015 s 1	0.337	0.068	F fleet 3 YR 1994 s 1	0.355	0.069
F fleet 1 YR 2016 s 1	0.372	0.055	F fleet 3 YR 1995 s 1	0.326	0.054
F fleet 1 YR 2017 s 1	0.409	0.063	F fleet 3 YR 1996 s 1	0.248	0.048
F fleet 1 YR 2018 s 1	0.397	0.058	F fleet 3 YR 1997 s 1	0.311	0.056
F fleet 1 YR 2019 s 1	0.619	0.119	F fleet 3 YR 1998 s 1	0.445	0.070
F fleet 1 YR 2020 s 1	0.384	0.062	F fleet 3 YR 1999 s 1	0.516	0.078
F fleet 1 YR 2021 s 1	0.289	0.047	F fleet 3 YR 2000 s 1	0.623	0.094
F fleet 1 YR 2022 s 1	0.236	0.037	F fleet 3 YR 2001 s 1	0.448	0.066
F fleet 2 YR 1981 s 1	0.001	0.001	F fleet 3 YR 2002 s 1	0.422	0.075
F fleet 2 YR 1982 s 1	0.031	0.010	F fleet 3 YR 2003 s 1	0.389	0.062
F fleet 2 YR 1983 s 1	0.114	0.035	F fleet 3 YR 2004 s 1	0.481	0.073
F fleet 2 YR 1984 s 1	0.161	0.041	F fleet 3 YR 2005 s 1	0.600	0.100
F fleet 2 YR 1985 s 1	0.117	0.023	F fleet 3 YR 2006 s 1	0.522	0.082
F fleet 2 YR 1986 s 1	0.082	0.017	F fleet 3 YR 2007 s 1	0.464	0.068
F fleet 2 YR 1987 s 1	0.069	0.014	F fleet 3 YR 2008 s 1	0.464	0.076
F fleet 2 YR 1988 s 1	0.058	0.014	F fleet 3 YR 2009 s 1	0.571	0.077
F fleet 2 YR 1989 s 1	0.061	0.019	F fleet 3 YR 2010 s 1	0.875	0.119
F fleet 2 YR 1990 s 1	0.065	0.016	F fleet 3 YR 2011 s 1	0.569	0.080
F fleet 2 YR 1991 s 1	0.030	0.007	F fleet 3 YR 2012 s 1	0.529	0.065
F fleet 2 YR 1992 s 1	0.058	0.012	F fleet 3 YR 2013 s 1	1.059	0.117
F fleet 2 YR 1993 s 1	0.076	0.016	F fleet 3 YR 2014 s 1	1.117	0.126
F fleet 2 YR 1994 s 1	0.082	0.019	F fleet 3 YR 2015 s 1	1.126	0.127
F fleet 2 YR 1995 s 1	0.061	0.014	F fleet 3 YR 2016 s 1	1.276	0.161
F fleet 2 YR 1996 s 1	0.040	0.010	F fleet 3 YR 2017 s 1	1.110	0.136
F fleet 2 YR 1997 s 1	0.021	0.005	F fleet 3 YR 2018 s 1	1.360	0.156
F fleet 2 YR 1998 s 1	0.029	0.008	F fleet 3 YR 2019 s 1	0.882	0.132
F fleet 2 YR 1999 s 1	0.055	0.012	F fleet 3 YR 2020 s 1	0.765	0.109
F fleet 2 YR 2000 s 1	0.097	0.020	F fleet 3 YR 2021 s 1	1.118	0.238
F fleet 2 YR 2001 s 1	0.085	0.015	F fleet 3 YR 2022 s 1	0.628	0.101

**Table 69. Fishing fleet initial fishing mortality, selectivity, retention, and discard mortality parameters for the southern stock SS base model.**

Parameter	Type	Final Value	SE	Lower Bound	Upper Bound	Prior Type	Prior Mean	Prior sd
InitF_seas_1_flt_1SC_Recreational	Estimated	0.387132	0.282795	0	2	Sym_Beta	NA	1
InitF_seas_1_flt_2GA_Recreational	Estimated	0.384828	0.317247	0	2	Sym_Beta	NA	1
InitF_seas_1_flt_3FL_Recreational	Estimated	0.232793	0.20728	0	2	Sym_Beta	NA	1
Size_DblN_peak_SC_Recreational(1)	Estimated	40.7149	0.907617	25	50	NA	NA	NA
Size_DblN_top_logit_SC_Recreational(1)	Fixed	-0.58	NA	NA	NA	NA	NA	NA
Size_DblN_ascend_se_SC_Recreational(1)	Estimated	4.72891	0.175817	0	6	NA	NA	NA
Size_DblN_descend_se_SC_Recreational(1)	Estimated	2.45946	0.744553	0	6	Sym_Beta	NA	0.5
Size_DblN_start_logit_SC_Recreational(1)	Fixed	-999	NA	NA	NA	NA	NA	NA
Size_DblN_end_logit_SC_Recreational(1)	Estimated	-1.21239	0.21056	-5	5	Normal	-1	0.24
Retain_L_infl_SC_Recreational(1)	Estimated	21.1226	1.40558	20	50	Sym_Beta	NA	0.5
Retain_L_width_SC_Recreational(1)	Estimated	2.80789	1.08471	0.1	10	Sym_Beta	NA	1
Retain_L_asymptote_logit_SC_Recreational(1)	Estimated	6.28367	2.64381	-10	10	Sym_Beta	NA	0.5
Retain_L_dome_infl_SC_Recreational(1)	Estimated	66.7396	1.77653	40	136	NA	NA	NA
Retain_L_dome_width_SC_Recreational(1)	Estimated	7.96906	1.09787	0.1	10	NA	NA	NA
DiscMort_L_level_old_SC_Recreational(1)	Fixed	0.08	NA	NA	NA	NA	NA	NA
Size_DblN_peak_GA_Recreational(2)	Estimated	42.9071	0.915095	25	50	NA	NA	NA
Size_DblN_top_logit_GA_Recreational(2)	Fixed	-0.58	NA	NA	NA	NA	NA	NA
Size_DblN_ascend_se_GA_Recreational(2)	Estimated	4.60169	0.144636	0	6	NA	NA	NA
Size_DblN_descend_se_GA_Recreational(2)	Estimated	1.03493	0.976845	0	6	NA	NA	NA
Size_DblN_start_logit_GA_Recreational(2)	Fixed	-999	NA	NA	NA	NA	NA	NA
Size_DblN_end_logit_GA_Recreational(2)	Estimated	-1.88959	0.271698	-5	5	NA	NA	NA
Retain_L_infl_GA_Recreational(2)	Estimated	18.8152	3.72958	15	50	Sym_Beta	NA	0.5
Retain_L_width_GA_Recreational(2)	Estimated	1.88757	1.27033	0.1	10	Sym_Beta	NA	0.5
Retain_L_asymptote_logit_GA_Recreational(2)	Estimated	7.06166	2.22996	-10	10	Sym_Beta	NA	0.5
Retain_L_dome_infl_GA_Recreational(2)	Estimated	65.2067	2.68031	40	136	NA	NA	NA
Retain_L_dome_width_GA_Recreational(2)	Estimated	4.55004	1.20427	0.001	10	NA	NA	NA
DiscMort_L_level_old_GA_Recreational(2)	Fixed	0.08	NA	NA	NA	NA	NA	NA
Size_DblN_peak_FL_Recreational(3)	Estimated	40.9572	0.669004	25	50	NA	NA	NA
Size_DblN_top_logit_FL_Recreational(3)	Fixed	-0.58	NA	NA	NA	NA	NA	NA
Size_DblN_ascend_se_FL_Recreational(3)	Estimated	4.56213	0.1512	0	6	NA	NA	NA
Size_DblN_descend_se_FL_Recreational(3)	Estimated	1.22613	0.560544	0	6	Sym_Beta	NA	0.5
Size_DblN_start_logit_FL_Recreational(3)	Fixed	-999	NA	NA	NA	NA	NA	NA
Size_DblN_end_logit_FL_Recreational(3)	Estimated	-2.26866	0.286901	-5	5	NA	NA	NA
Retain_L_infl_FL_Recreational(3)	Estimated	16.8056	2.31528	15	60	Sym_Beta	NA	0.5
Retain_L_width_FL_Recreational(3)	Estimated	3.92246	1.80195	0.1	10	NA	NA	NA
Retain_L_asymptote_logit_FL_Recreational(3)	Estimated	6.42745	2.5716	-10	10	Sym_Beta	NA	0.5
Retain_L_dome_infl_FL_Recreational(3)	Estimated	76.1535	4.84684	40	136	NA	NA	NA
Retain_L_dome_width_FL_Recreational(3)	Estimated	9.45392	1.94115	0.001	14	NA	NA	NA
DiscMort_L_level_old_FL_Recreational(3)	Fixed	0.08	NA	NA	NA	NA	NA	NA
Retain_L_infl_SC_Recreational(1)_BLK1repl_1990	Estimated	34.593	0.65595	20	50	NA	NA	NA
Retain_L_infl_SC_Recreational(1)_BLK1repl_2001	Estimated	38.9051	0.26932	20	50	NA	NA	NA
Retain_L_width_SC_Recreational(1)_BLK1repl_1990	Estimated	2.68908	0.366486	0.1	10	NA	NA	NA
Retain_L_width_SC_Recreational(1)_BLK1repl_2001	Estimated	1.09461	0.144402	0.1	10	NA	NA	NA
Retain_L_asymptote_logit_SC_Recreational(1)_BLK8repl_1990	Estimated	5.93546	2.83576	-10	10	Sym_Beta	NA	0.5
Retain_L_asymptote_logit_SC_Recreational(1)_BLK8repl_2001	Estimated	0.542263	0.291827	-10	10	NA	NA	NA
Retain_L_asymptote_logit_SC_Recreational(1)_BLK8repl_2007	Estimated	-0.133363	0.15997	-10	10	NA	NA	NA
Retain_L_asymptote_logit_SC_Recreational(1)_BLK8repl_2018	Estimated	-0.558014	0.166308	-10	10	NA	NA	NA
Retain_L_dome_infl_SC_Recreational(1)_BLK2repl_1993	Estimated	55.4332	1.63726	40	136	NA	NA	NA
Retain_L_dome_infl_SC_Recreational(1)_BLK2repl_2001	Estimated	59.5762	0.434335	40	136	NA	NA	NA
Retain_L_dome_width_SC_Recreational(1)_BLK2repl_1993	Estimated	6.29844	0.718631	0.001	10	NA	NA	NA
Retain_L_dome_width_SC_Recreational(1)_BLK2repl_2001	Estimated	1.91983	0.230264	0.001	10	NA	NA	NA
Retain_L_infl_GA_Recreational(2)_BLK7repl_1986	Estimated	39.4127	0.227114	20	50	NA	NA	NA
Retain_L_width_GA_Recreational(2)_BLK7repl_1986	Estimated	1.65524	0.113136	0.1	10	NA	NA	NA
Retain_L_dome_infl_GA_Recreational(2)_BLK4repl_1986	Estimated	53.4486	1.35859	40	136	NA	NA	NA
Retain_L_dome_infl_GA_Recreational(2)_BLK4repl_1993	Estimated	58.9747	1.45055	40	136	NA	NA	NA
Retain_L_dome_infl_GA_Recreational(2)_BLK4repl_2002	Estimated	53.3712	0.5714	40	136	NA	NA	NA
Retain_L_dome_width_GA_Recreational(2)_BLK4repl_1986	Estimated	7.08237	0.6724	0.001	10	NA	NA	NA
Retain_L_dome_width_GA_Recreational(2)_BLK4repl_1993	Estimated	6.5589	0.740943	0.001	10	NA	NA	NA
Retain_L_dome_width_GA_Recreational(2)_BLK4repl_2002	Estimated	4.2685	0.277171	0.001	10	NA	NA	NA
Retain_L_infl_FL_Recreational(3)_BLK9repl_1985	Estimated	52.5329	0.629955	20	60	NA	NA	NA
Retain_L_width_FL_Recreational(3)_BLK9repl_1985	Estimated	3.80333	0.192994	0.1	10	NA	NA	NA
Retain_L_asymptote_logit_FL_Recreational(3)_BLK6repl_1989	Estimated	0.0451433	0.180606	-10	10	Sym_Beta	NA	2
Retain_L_dome_infl_FL_Recreational(3)_BLK6repl_1989	Estimated	72.1848	1.2567	40	136	NA	NA	NA
Retain_L_dome_width_FL_Recreational(3)_BLK6repl_1989	Estimated	5.03376	0.738374	0.001	10	NA	NA	NA

**Table 70. Survey catchability coefficient and selectivity parameters for the southern stock SS base model.**

Parameter	Type	Final Value	SE	Lower Bound	Upper Bound	Prior Type	Prior Mean	Prior sd
LnQ_base_FL_21.3_HaulSeine(4)	Derived	-8.57384	NA	NA	NA	NA	NA	NA
LnQ_base_SC_Rotenone(5)	Derived	-8.76956	NA	NA	NA	NA	NA	NA
LnQ_base_GA_GillNet(6)	Derived	-8.25778	NA	NA	NA	NA	NA	NA
LnQ_base_SC_StopNet(7)	Derived	-8.77237	NA	NA	NA	NA	NA	NA
LnQ_base_SC_Trammel(9)	Derived	-8.46373	NA	NA	NA	NA	NA	NA
LnQ_base_FL_183_HaulSeine(10)	Derived	-8.39557	NA	NA	NA	NA	NA	NA
LnQ_base_SC_Longline_contemporary(11)	Derived	-7.46883	NA	NA	NA	NA	NA	NA
Size_inflection_SC_Longline_contemporary(11)	Fixed	91.5	NA	NA	NA	NA	NA	NA
Size_95%width_SC_Longline_contemporary(11)	Fixed	9	NA	NA	NA	NA	NA	NA
minage@sel=1_GA_GillNet(6)	Fixed	0	NA	NA	NA	NA	NA	NA
maxage@sel=1_GA_GillNet(6)	Fixed	0	NA	NA	NA	NA	NA	NA
Age_DblN_peak_SC_StopNet(7)	Estimated	1.08048	0.161872	0.1	2.75	NA	NA	NA
Age_DblN_top_logit_SC_StopNet(7)	Estimated	-7.05522	5.29895	-15	3	Sym Beta	NA	0.5
Age_DblN_ascend_se_SC_StopNet(7)	Estimated	0.43009	0.350238	0.001	4	Sym Beta	NA	0.5
Age_DblN_descend_se_SC_StopNet(7)	Estimated	0.415558	0.350364	0.001	4	Sym Beta	NA	0.7
Age_DblN_start_logit_SC_StopNet(7)	Fixed	-999	NA	NA	NA	NA	NA	NA
Age_DblN_end_logit_SC_StopNet(7)	Fixed	-999	NA	NA	NA	NA	NA	NA
Age_DblN_peak_SC_Trammel(9)	Estimated	1.87335	0.054628	0.1	2.75	NA	NA	NA
Age_DblN_top_logit_SC_Trammel(9)	Estimated	-11.2942	2.68111	-15	3	Sym Beta	NA	0.5
Age_DblN_ascend_se_SC_Trammel(9)	Estimated	0.635266	0.038162	0.1	1	NA	NA	NA
Age_DblN_descend_se_SC_Trammel(9)	Estimated	0.477555	0.046565	0.1	4	NA	NA	NA
Age_DblN_start_logit_SC_Trammel(9)	Fixed	-999	NA	NA	NA	NA	NA	NA
Age_DblN_end_logit_SC_Trammel(9)	Fixed	-999	NA	NA	NA	NA	NA	NA
Age_DblN_peak_FL_183_HaulSeine(10)	Estimated	1.3099	0.039454	0.1	1.8	NA	NA	NA
Age_DblN_top_logit_FL_183_HaulSeine(10)	Estimated	-10.9402	5.47114	-13	3	Sym Beta	NA	0.05
Age_DblN_ascend_se_FL_183_HaulSeine(10)	Estimated	0.0531751	0.031727	0.001	4	Sym Beta	NA	2.5
Age_DblN_descend_se_FL_183_HaulSeine(10)	Estimated	0.176639	0.104857	0.001	4	Sym Beta	NA	0.5
Age_DblN_start_logit_FL_183_HaulSeine(10)	Fixed	-999	NA	NA	NA	NA	NA	NA
Age_DblN_end_logit_FL_183_HaulSeine(10)	Fixed	-999	NA	NA	NA	NA	NA	NA

**Table 71. Jitter analysis results for the southern stock SS model. The -LL column shows the change in total negative log-likelihood relative to the base model.**

-LL	Δ -LL	Frequency	Converged?
7,345	0	192	Yes
7,352	7	1	Yes
7,352	7	1	Yes
7,366	22	1	Yes
9,093	1,748	1	No
9,698	2,353	1	No
9,925	2,580	1	No
13,533	6,188	1	No
22,632	15,287	1	No



**Table 73. Female spawning stock biomass estimates for the southern stock SS base model. 95% confidence intervals are based on asymptotic standard errors.**

Year	Annual SSB (metric tons)			Annual Relative SSB			Three-Year Average Relative SSB
	LCI	Estimate	UCI	LCI	Estimate	UCI	
Unfished	28,235	33,252	38,269	NA	NA	NA	NA
Target	11,303	13,250	15,198	NA	NA	NA	NA
Threshold	8,459	9,917	11,374	NA	1.000	NA	1.000
1981	1,306	2,629	3,951	0.146	0.264	0.381	NA
1982	1,419	2,729	4,039	0.158	0.274	0.389	NA
1983	1,421	2,646	3,871	0.158	0.265	0.372	0.267
1984	1,320	2,421	3,521	0.147	0.243	0.338	0.260
1985	1,239	2,240	3,240	0.139	0.225	0.310	0.244
1986	1,201	2,143	3,085	0.136	0.215	0.294	0.227
1987	1,358	2,327	3,296	0.155	0.233	0.312	0.224
1988	1,736	2,898	4,060	0.202	0.291	0.379	0.246
1989	2,470	4,055	5,640	0.292	0.406	0.521	0.310
1990	3,484	5,681	7,879	0.416	0.570	0.723	0.422
1991	4,622	7,504	10,387	0.557	0.752	0.948	0.576
1992	5,517	8,977	12,437	0.669	0.900	1.131	0.741
1993	6,289	10,147	14,004	0.766	1.017	1.269	0.890
1994	7,111	11,345	15,579	0.868	1.137	1.407	1.018
1995	7,968	12,640	17,313	0.975	1.267	1.559	1.141
1996	8,683	13,730	18,777	1.065	1.376	1.688	1.260
1997	9,165	14,443	19,722	1.125	1.448	1.771	1.364
1998	9,546	14,956	20,366	1.172	1.499	1.827	1.441
1999	9,728	15,200	20,672	1.195	1.524	1.853	1.490
2000	9,700	15,144	20,587	1.192	1.518	1.844	1.514
2001	9,452	14,787	20,121	1.162	1.482	1.802	1.508
2002	9,266	14,481	19,695	1.139	1.452	1.764	1.484
2003	9,148	14,243	19,337	1.124	1.428	1.731	1.454
2004	9,395	14,502	19,609	1.153	1.454	1.754	1.444
2005	10,002	15,330	20,658	1.226	1.537	1.847	1.473
2006	10,571	16,219	21,867	1.296	1.626	1.956	1.539
2007	10,855	16,704	22,553	1.331	1.674	2.018	1.612
2008	10,791	16,632	22,474	1.324	1.667	2.011	1.656
2009	10,441	16,089	21,736	1.281	1.613	1.945	1.652
2010	10,053	15,456	20,859	1.233	1.549	1.866	1.610
2011	9,591	14,805	20,018	1.177	1.484	1.792	1.549
2012	9,484	14,606	19,728	1.163	1.464	1.766	1.499
2013	9,504	14,567	19,630	1.164	1.460	1.757	1.470
2014	9,233	14,184	19,135	1.131	1.422	1.713	1.449
2015	8,700	13,445	18,189	1.067	1.348	1.629	1.410
2016	8,028	12,474	16,920	0.985	1.250	1.516	1.340
2017	7,275	11,366	15,457	0.894	1.139	1.385	1.246
2018	6,605	10,350	14,094	0.812	1.037	1.263	1.142
2019	5,952	9,398	12,845	0.732	0.942	1.152	1.040
2020	5,481	8,705	11,929	0.675	0.873	1.070	0.951
2021	5,199	8,276	11,353	0.641	0.830	1.019	0.881
2022	4,919	7,878	10,837	0.607	0.790	0.973	0.831

**Table 74. Age-2 fishing mortality (F) and spawning potential ratio (SPR) estimates for the southern stock SS base model. 95% confidence intervals are based on asymptotic standard errors.**

Year	Age-2 F			Annual SPR			Three-Year Average SPR
	LCI	Estimate	UCI	LCI	Estimate	UCI	
Target	0.290	0.301	0.311	NA	0.400	NA	0.400
Threshold	0.382	0.396	0.410	NA	0.300	NA	0.300
1981	0.074	0.193	0.312	0.272	0.487	0.701	NA
1982	0.293	0.785	1.276	-0.042	0.056	0.154	NA
1983	0.709	1.168	1.626	-0.009	0.015	0.039	0.186
1984	0.496	0.802	1.109	-0.006	0.055	0.115	0.042
1985	0.332	0.530	0.728	0.058	0.169	0.280	0.080
1986	0.086	0.143	0.200	0.491	0.612	0.733	0.279
1987	0.127	0.219	0.311	0.323	0.470	0.617	0.417
1988	0.063	0.109	0.156	0.565	0.679	0.794	0.587
1989	0.070	0.122	0.174	0.553	0.667	0.781	0.605
1990	0.068	0.124	0.180	0.549	0.671	0.793	0.672
1991	0.101	0.184	0.267	0.435	0.577	0.719	0.638
1992	0.086	0.130	0.175	0.578	0.671	0.764	0.640
1993	0.109	0.162	0.215	0.507	0.607	0.708	0.618
1994	0.138	0.210	0.281	0.416	0.532	0.648	0.603
1995	0.141	0.210	0.279	0.401	0.518	0.634	0.552
1996	0.118	0.186	0.255	0.414	0.541	0.669	0.530
1997	0.105	0.157	0.209	0.528	0.626	0.724	0.562
1998	0.153	0.218	0.283	0.423	0.526	0.629	0.564
1999	0.182	0.255	0.329	0.370	0.475	0.579	0.542
2000	0.222	0.309	0.395	0.307	0.413	0.518	0.471
2001	0.177	0.243	0.309	0.401	0.498	0.595	0.462
2002	0.150	0.217	0.285	0.422	0.527	0.633	0.479
2003	0.149	0.208	0.267	0.445	0.541	0.638	0.522
2004	0.172	0.238	0.305	0.400	0.500	0.599	0.523
2005	0.224	0.317	0.411	0.284	0.393	0.502	0.478
2006	0.207	0.289	0.371	0.321	0.426	0.531	0.439
2007	0.192	0.260	0.328	0.360	0.456	0.551	0.425
2008	0.193	0.266	0.338	0.350	0.448	0.547	0.443
2009	0.237	0.310	0.382	0.309	0.397	0.484	0.434
2010	0.366	0.480	0.593	0.157	0.240	0.322	0.362
2011	0.219	0.293	0.366	0.329	0.422	0.515	0.353
2012	0.232	0.295	0.359	0.332	0.413	0.494	0.358
2013	0.424	0.526	0.629	0.149	0.216	0.282	0.350
2014	0.489	0.608	0.728	0.105	0.164	0.224	0.264
2015	0.470	0.586	0.702	0.116	0.179	0.241	0.186
2016	0.542	0.680	0.818	0.080	0.134	0.188	0.159
2017	0.514	0.636	0.757	0.094	0.148	0.202	0.153
2018	0.592	0.739	0.887	0.060	0.109	0.159	0.130
2019	0.423	0.558	0.693	0.103	0.178	0.252	0.145
2020	0.333	0.439	0.544	0.179	0.264	0.348	0.184
2021	0.383	0.580	0.777	0.079	0.179	0.279	0.207
2022	0.311	0.424	0.537	0.168	0.262	0.356	0.235

**Table 75. Input data types for traffic light analysis characteristics selected for the red drum TLA framework and the stock status each characteristic is used to indicate.**

Characteristic	Input Data Type	Stock Status
Recruitment	Recruitment (age-1) index of abundance	Recruitment Condition
Adult Abundance	Longline Survey of adult abundance	Spawning Stock Biomass
Fishery Performance	Harvest of slot-sized fish divided by slot-sized index of abundance	Fishing Mortality

**Table 76. Data sources for each traffic light analysis characteristic selected for the red drum TLA framework.**

Characteristic	Northern	Southern
Recruitment	NC_BagSeine	FL_21.3_HaulSeine
Adult Abundance	NC_Longline	GA_Longline SC_Longline_contemporary
Fishery Performance	NC_Gillnet	FL_183_HaulSeine SC_Trammel

**Table 77. Threshold values for the northern stock optimized from the grid square method. The estimated threshold for adult abundance, 0.78, was halved to serve as a more conservative metric for the assessment.**

Characteristics	Years to Trigger Management Action	Threshold
Recruitment	1	0.05
Adult Abundance	10	0.78 (0.39)
Fishery Performance	7	0.76

**Table 78. Threshold values for the southern stock optimized from the grid square method. The estimated threshold for adult abundance, 0.78, was halved to serve as a more conservative metric for the assessment.**

Characteristics	Years to Trigger Management Action	Threshold
Recruitment	1	0.05
Adult Abundance	9	0.78 (0.39)
Fishery Performance	6	0.52

**Table 79. Action results derived from the TLA model for the northern stock. The terminal fishing year used for stock status in the assessment is 2021.**

Year	Recruitment	Adult_Abundance	Fishery_Performance
2018	No Action	No Action	Moderate Action
2019	Moderate Action	No Action	Moderate Action
2020	Moderate Action	No Action	Moderate Action
<b>2021</b>	<b>Moderate Action</b>	<b>No Action</b>	<b>Moderate Action</b>

**Table 80. Action results derived from the TLA model for the southern stock. The terminal fishing year used for stock status in the assessment is 2021.**

Year	Recruitment	Adult_Abundance	Fishery_Performance
<b>2018</b>	Elevated Action	Moderate Action	Elevated Action
<b>2019</b>	Elevated Action	Moderate Action	Elevated Action
<b>2020</b>	Elevated Action	Moderate Action	Elevated Action
<b>2021</b>	<b>Elevated Action</b>	<b>Moderate Action</b>	<b>Elevated Action</b>

**Table 81. Action results for the northern stock based on sensitivity runs evaluating changes in duration of reference period. A total of 8 different scenarios were evaluated. Results including the base reference period are in bold.**

Recruitment	Adult_Abundance	Fishery_Performance	Frequency
<b>Moderate Action</b>	<b>No Action</b>	<b>Moderate Action</b>	<b>6</b>
Moderate Action	No Action	Elevated Action	2

**Table 82. Action results for the southern stock based on sensitivity runs evaluating changes in duration of reference period. A total of 11 different scenarios were evaluated. Results including the base reference period are in bold.**

Recruitment	Adult_Abundance	Fishery_Performance	Frequency
<b>Elevated Action</b>	<b>Moderate Action</b>	<b>Elevated Action</b>	<b>4</b>
Elevated Action	No Action	Elevated Action	7



**Table 83. NCDMF gill net survey red drum index (annual; 3-yr avg), MRIP North Carolina and areas north recreational harvest plus North Carolina commercial harvest (annual; 3-yr avg.), normalized catch:index ratio ( $Catch/Index_{norm,y}$ ), recommended catch ( $Catch/Index_{norm,y}$ ), and proportion change in catch relative to previous year as estimated using Skate methodology by fishing year. Bolded values indicate years with recommended catch reductions.**

Fishing Year	Index		MRIP Landings (mt)		$Catch/$ $Index_{norm,y}$	$C_{rec,y}$	$Catch \Delta$
	Annual	3-yr Avg	Annual	3-yr Avg			
2002	-	-	450	-	-	-	-
2003	1.6536	-	256	-	-	-	-
2004	6.0570	-	125	277	-	-	-
2005	6.5471	4.7526	399	260	0.3112	835	2.0185
2006	3.6748	5.4263	501	342	0.3585	953	2.6686
2007	2.1338	4.1186	703	534	0.7386	724	1.1169
2008	4.7824	3.5303	534	579	0.9342	620	0.1606
2009	4.5960	3.8374	786	674	1.0000	674	0.1636
2010	5.1413	4.8399	465	595	0.6998	850	0.2612
2011	0.7280	3.4884	523	591	0.9646	613	0.0299
	11.958						
2012	2	5.9425	779	589	0.5641	1044	0.7661
2013	5.6985	6.1282	1964	1089	1.0110	1077	0.8281
2014	3.5947	7.0838	607	1117	0.8972	1245	0.1433
2015	3.1350	4.1427	293	955	1.3114	728	<b>-0.3482</b>
2016	4.1374	3.6224	1096	665	1.0450	636	<b>-0.3332</b>
2017	2.4912	3.2545	1165	851	1.4885	572	<b>-0.1402</b>
2018	1.4726	2.7004	383	881	1.8573	474	<b>-0.4426</b>
2019	6.1438	3.3692	772	773	1.3062	592	<b>-0.3282</b>
2020	5.2320	4.2828	1531	895	1.1894	752	<b>-0.0268</b>
2021	4.3201	5.2320	1301	1201	1.3067	919	0.0271
2022*	2.6617	4.0713	725	1186	1.6576	715	<b>-0.4045</b>

\* - Note, data not used in estimation of relative F to be consistent with other analyses presented herein

**Table 84. SCDNR trammel net age-2 and -3 red drum index (annual; 3-yr avg), MRIP South Carolina recreational harvest (annual; 3-yr avg.), normalized catch:index ratio ( $Catch/Index_{norm,y}$ ), recommended catch ( $Catch/Index_{norm,y}$ ), and proportion change in catch relative to previous year as estimated using Skate methodology by fishing year. Bolded values indicate years with recommended catch reductions.**

Fishing Year	MRIP Landings (mt)				$Catch/Index_{norm,y}$	$C_{rec,y}$	Catch $\Delta$
	Index		Annual	3-yr Avg			
	Annual	3-yr Avg					
1990	-	-	469	-	-	-	-
	10.704						
1991	4	-	415	-	-	-	-
1992	6.9499	-	451	445	-	-	-
1993	8.5922	8.7488	379	415	0.4841	858	0.9259
1994	4.8725	6.8049	152	327	0.4909	667	0.6068
1995	5.9990	6.4879	515	348	0.5479	636	0.9424
1996	3.3751	4.7489	449	372	0.7990	465	0.3360
1997	2.3806	3.9182	271	412	1.0720	384	0.0326
1998	2.8241	2.8599	221	314	1.1201	280	<b>-0.3191</b>
1999	1.3920	2.1989	154	216	1.0000	216	<b>-0.3136</b>
2000	2.8232	2.3464	100	158	0.6885	230	0.0671
2001	5.8165	3.3439	192	149	0.4533	328	1.0698
2002	4.0192	4.2196	217	170	0.4101	414	1.7837
2003	5.3573	5.0643	364	258	0.5192	496	1.9268
2004	4.8220	4.7328	227	270	0.5811	464	0.7999
2005	4.8801	5.0198	279	290	0.5895	492	0.8252
2006	2.3181	4.0067	165	224	0.5698	393	0.3540
2007	2.8977	3.3653	174	206	0.6245	330	0.4740
2008	2.3609	2.5256	240	193	0.7800	248	0.2018
2009	4.4808	3.2465	335	250	0.7847	318	0.6480
2010	2.3925	3.0781	610	395	1.3096	302	0.2083
2011	1.8807	2.9180	280	409	1.4286	286	<b>-0.2761</b>
2012	1.3845	1.8859	532	474	2.5653	185	<b>-0.5476</b>
2013	1.6180	1.6277	238	350	2.1941	160	<b>-0.6635</b>
2014	1.2617	1.4214	426	398	2.8599	139	<b>-0.6020</b>
2015	1.0553	1.3117	300	321	2.4988	129	<b>-0.6773</b>
2016	0.7976	1.0382	397	374	3.6765	102	<b>-0.6832</b>
2017	1.4418	1.0982	368	355	3.2966	108	<b>-0.7123</b>
2018	1.1869	1.1421	315	360	3.2136	112	<b>-0.6845</b>
2019	0.5204	1.0497	347	343	3.3376	103	<b>-0.7140</b>
2020	1.4517	1.0530	264	309	2.9932	103	<b>-0.6994</b>
2021	0.6881	0.8867	242	285	3.1618	90	<b>-0.7085</b>
2022*	1.5751	1.2383	260	256	2.0324	126	<b>-0.5583</b>

\* - Note, data not used in estimation of relative F to be consistent with other analyses presented herein

**Table 85. FL FWRI 183 m haul seine red drum index (annual; 3-yr avg), MRIP Florida recreational harvest (annual; 3-yr avg.), normalized catch:index ratio ( $Catch/Index_{norm,y}$ ), recommended catch ( $Catch/Index_{norm,y}$ ), and proportion change in catch relative to previous year as estimated using Skate methodology by fishing year. Bolded values indicate years with recommended catch reductions.**

Fishing Year	Index		MRIP Landings (mt)		$Catch/Index_{norm,y}$	$C_{rec,y}$	Catch $\Delta$
	Annual	3-yr Avg	Annual	3-yr Avg			
2000	-	-	1449	-	-	-	-
2001	0.00849	-	941	-	-	-	-
2002	0.00623	-	1245	1211	-	-	-
2003	0.01212	0.00895	1085	1090	0.5582	1953	0.6121
2004	0.00793	0.00876	1044	1124	0.5880	1912	0.7542
2005	0.00940	0.00982	1093	1074	0.5011	2143	0.9056
2006	0.00441	0.00725	1064	1067	0.6744	1582	0.4730
2007	0.00581	0.00654	706	954	0.6686	1427	0.3381
2008	0.00457	0.00493	802	857	0.7967	1076	0.1277
2009	0.00975	0.00671	1362	957	0.6530	1465	0.7087
2010	0.00791	0.00741	1247	1137	0.7029	1617	0.6906
2011	0.00598	0.00788	1455	1354	0.7876	1720	0.5127
2012	0.00525	0.00638	1474	1392	1.0000	1392	0.0276
2013	0.00317	0.00480	2343	1757	1.6779	1047	<b>-0.2475</b>
2014	0.00381	0.00408	2050	1956	2.1983	890	<b>-0.4937</b>
2015	0.00361	0.00353	1479	1957	2.5399	771	<b>-0.6059</b>
2016	0.00369	0.00371	2734	2088	2.5811	809	<b>-0.5868</b>
2017	0.00274	0.00335	1810	2008	2.7462	731	<b>-0.6498</b>
2018	0.00459	0.00368	2348	2297	2.8637	802	<b>-0.6004</b>
2019	0.00256	0.00330	895	1684	2.3400	720	<b>-0.6867</b>
2020	0.00339	0.00351	944	1395	1.8201	767	<b>-0.5448</b>
2021	0.00604	0.00400	1107	982	1.1257	872	<b>-0.3749</b>
2022*	0.00736	0.00560	585	879	0.7193	1222	0.2441

\* - Note, data not used in estimation of relative F to be consistent with other analyses presented herein

11 FIGURES

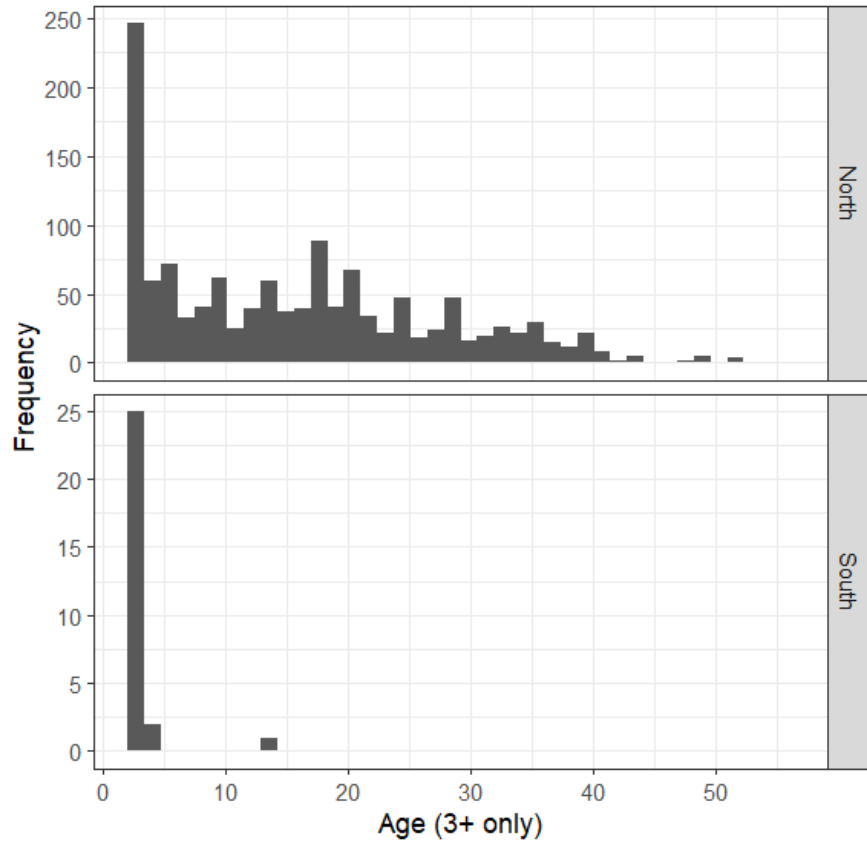


Figure 1. Age frequency of red drum captured north of the White Oak River in North Carolina versus within and south of the White Oak River for ages 3+.

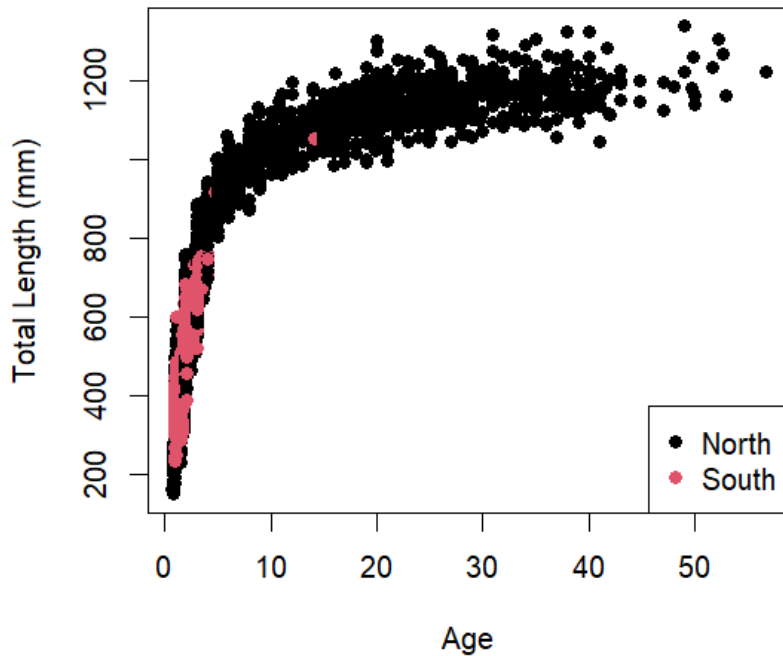
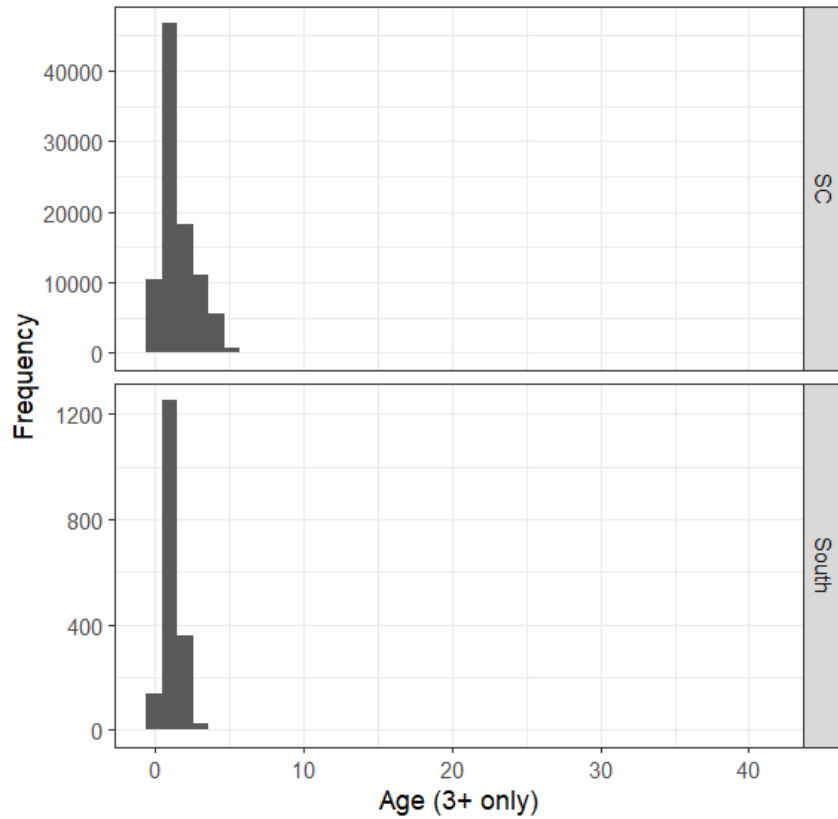
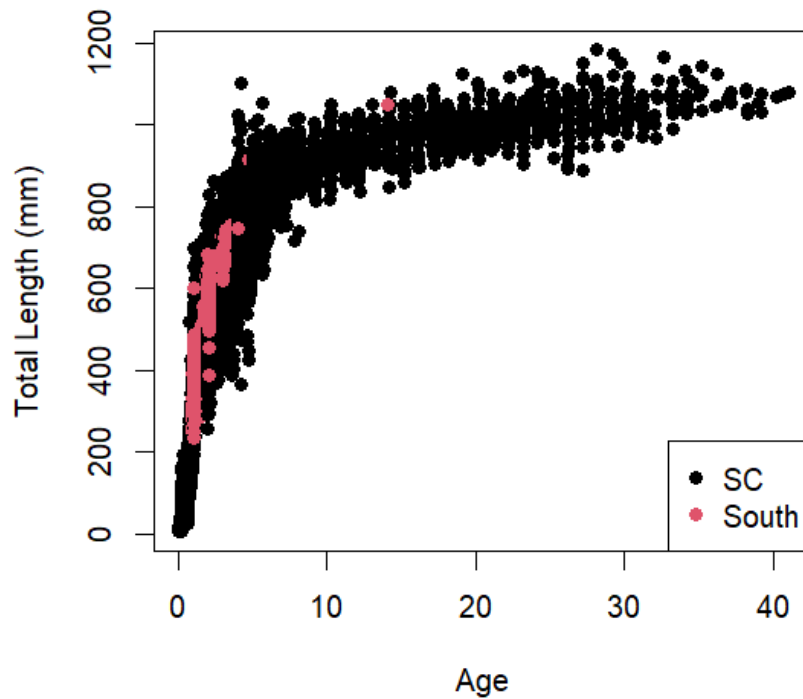


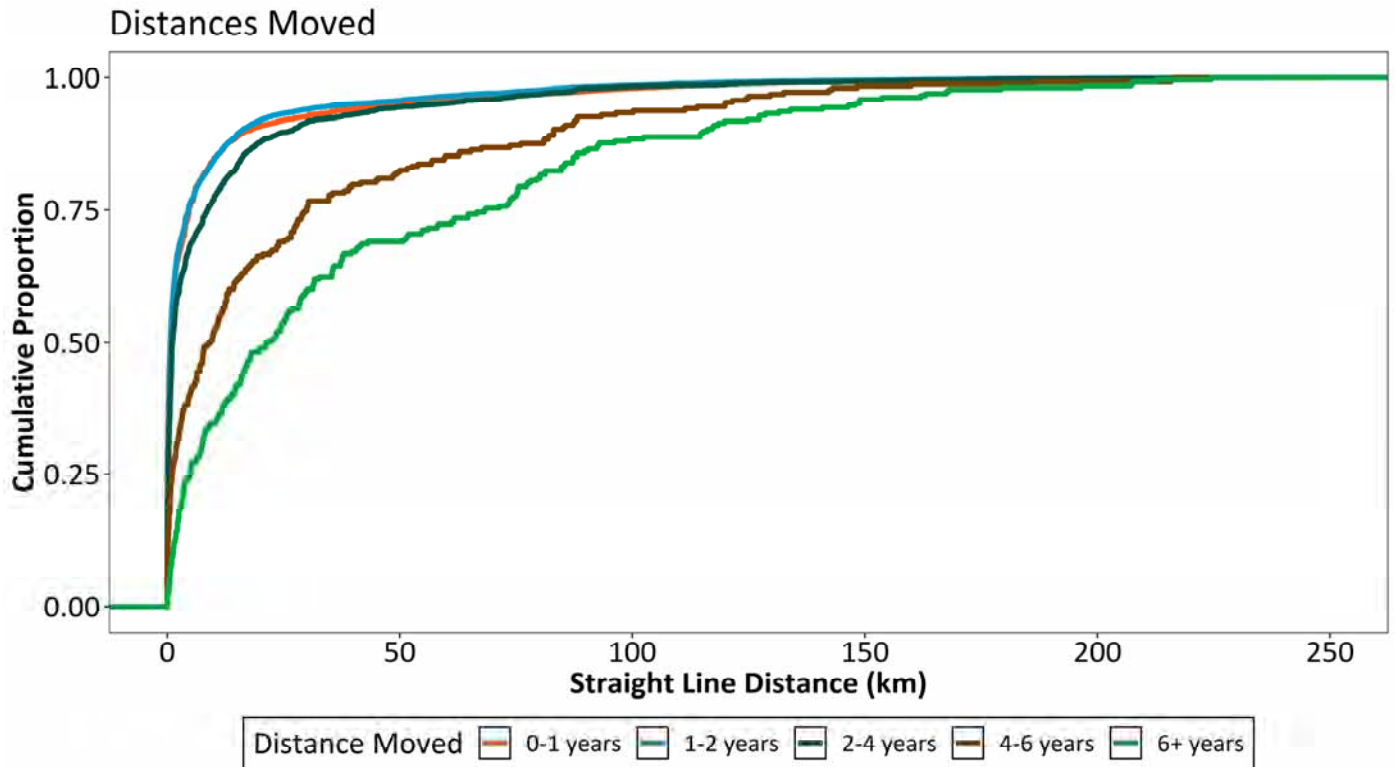
Figure 2. Fit of the von Bertalanffy age-length model to available biological data for red drum captured north of the White Oak River (black dots) and within or south of the White Oak River (red dots).



**Figure 3. Age frequency of red drum captured in South Carolina and red drum captured south of the White Oak River in North Carolina for ages 3+.**



**Figure 4. Fit of Von Bertalanffy age-length model to available biological data for red drum captured in South Carolina (black dots) and red drum captured south of the White Oak River in North Carolina (red dots).**



**Figure 5.** Cumulative proportion of tag recaptures as a function of straight line distance (km) and time-at-large. Time-at-large is split into 5 groups, 0-1 years (orange), 1-2 years (blue), 2-4 years (dark green), 4-6 years (brown), and 6+ years (light green). Fish were tagged as part of SCDNR’s Marine Gamefish Tagging and fishery-independent tagging programs.

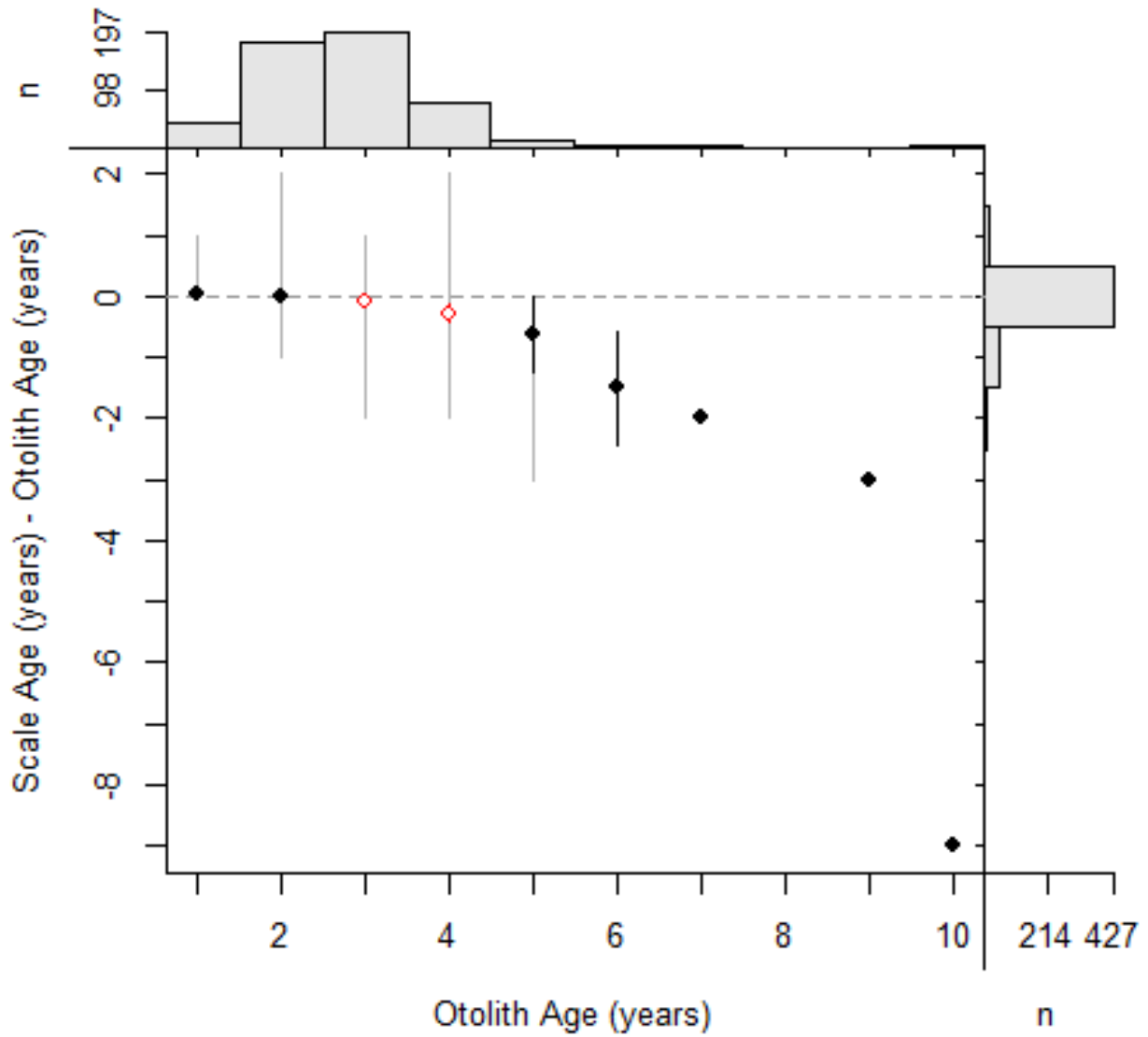
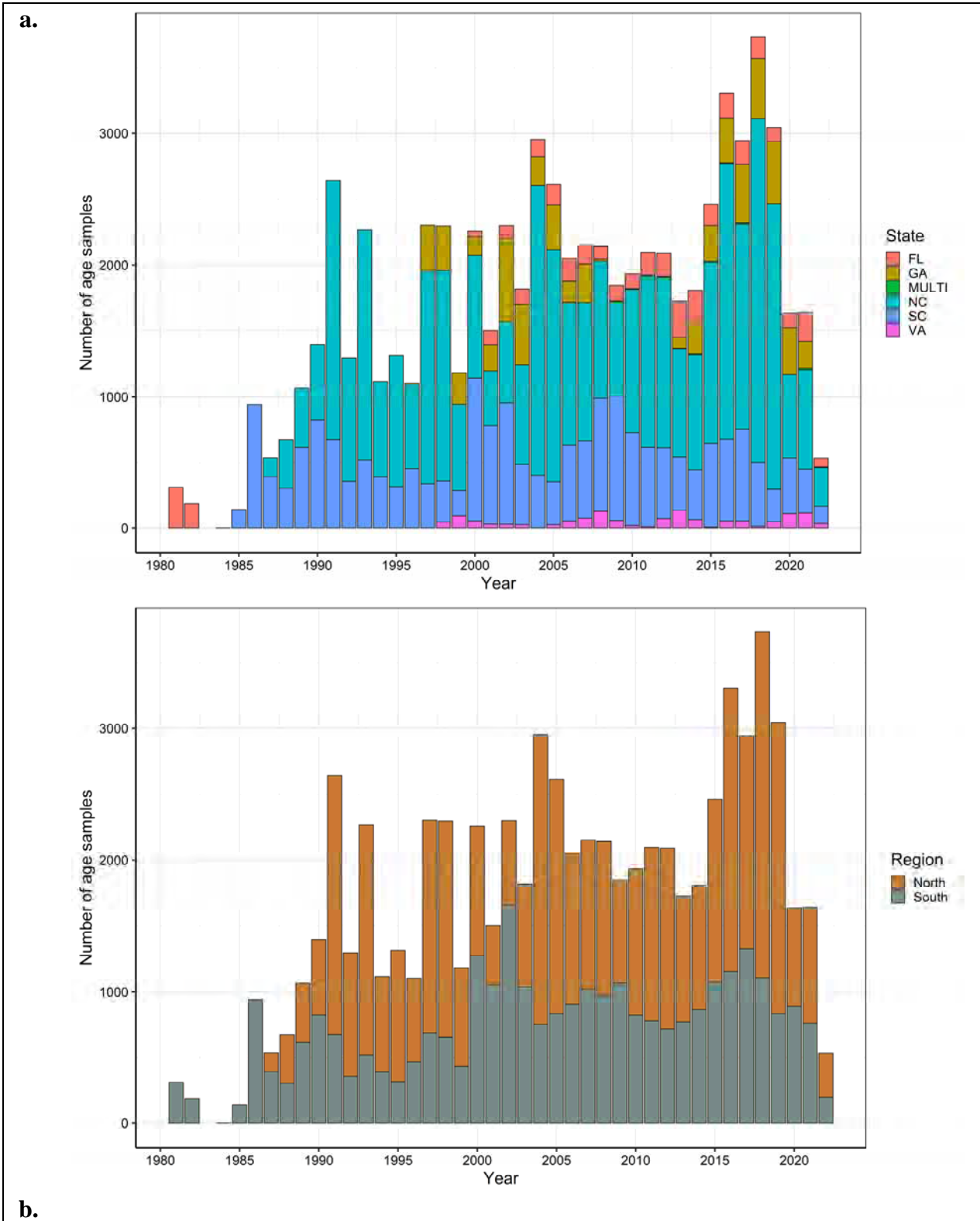
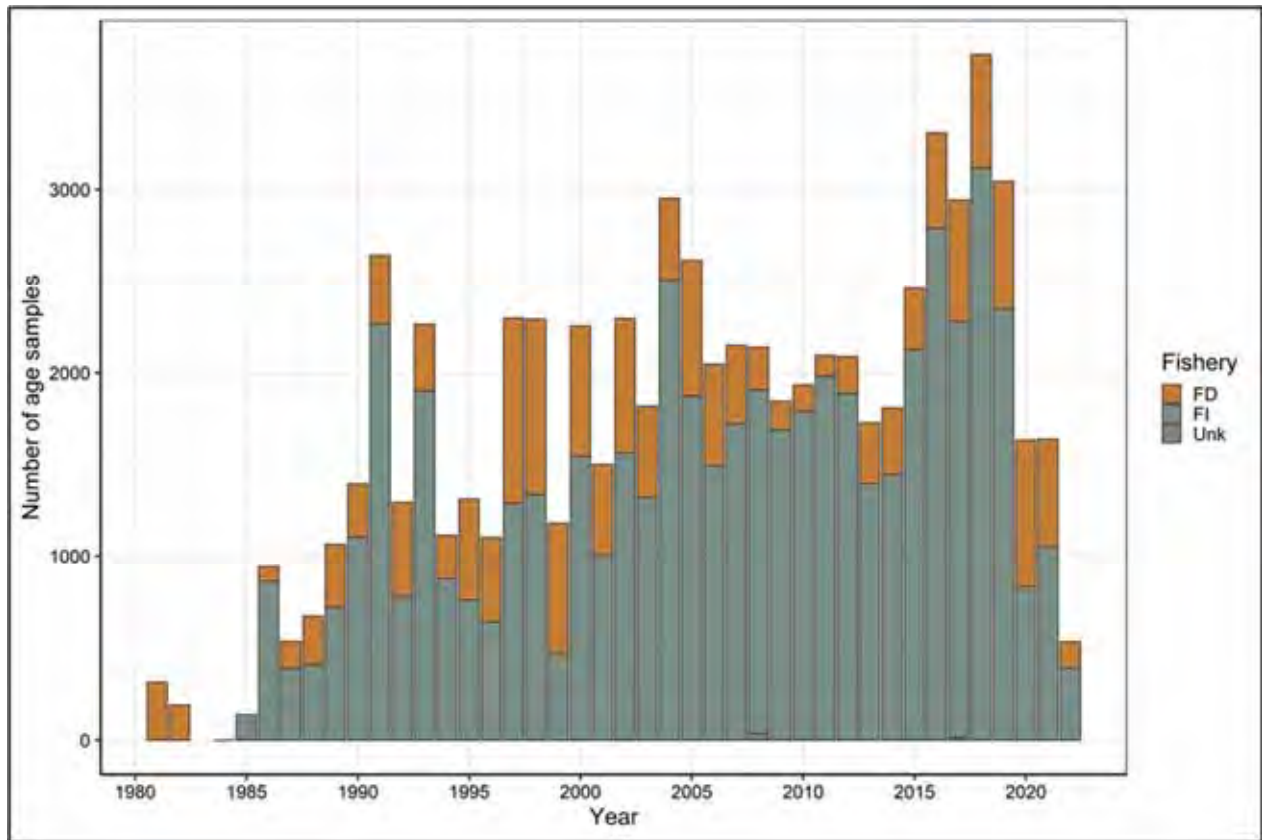


Figure 6. Age bias plot depicting the mean difference in scale - otolith derived ages for a given otolith derived age. Provided are the mean difference (symbol), 95% CI (black bars) and range of difference in age determinations (gray bars). Marginal histograms are provided showing the numbers of individuals given a particular age based on otolith (top histogram) and scale (right histogram) reads.

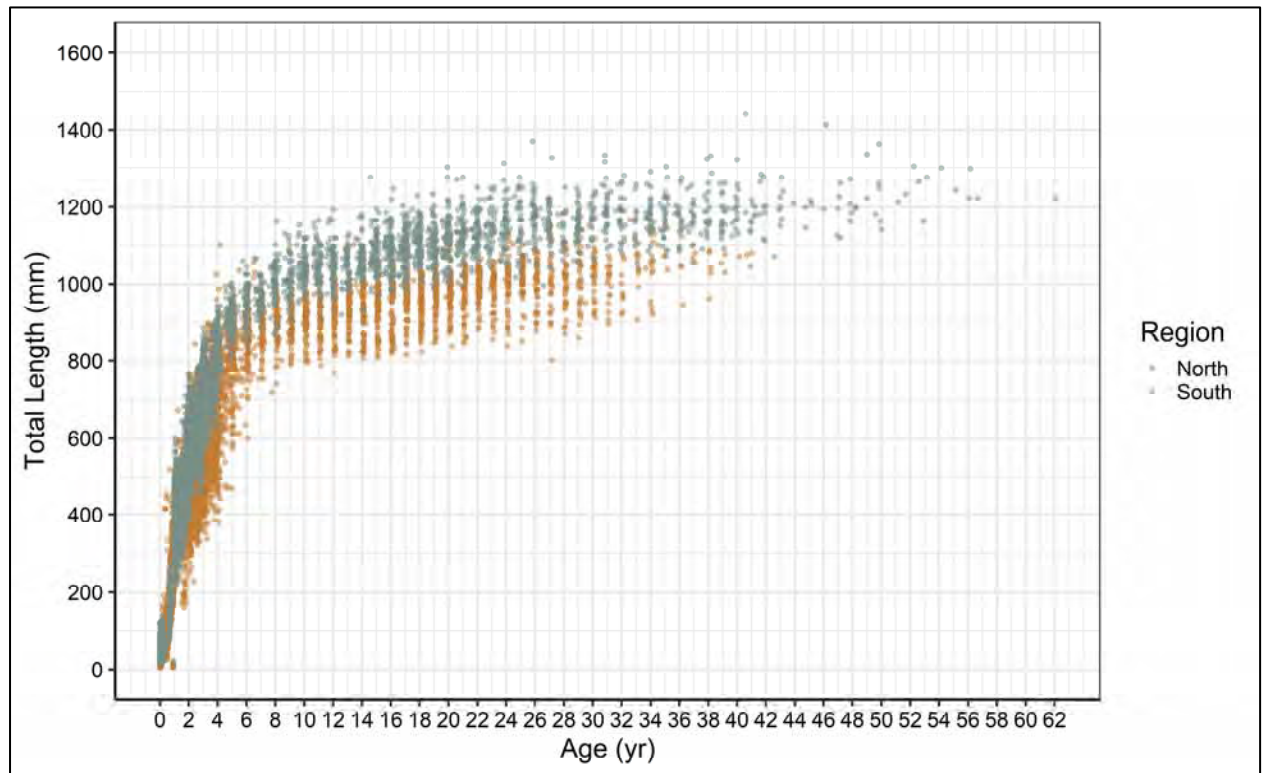


**Figure 7. Number of red drum age samples collected by stock/region (a.) and by state (b.) on the Atlantic coast of the U.S. from 1981 – 2022.**





**Figure 8. Number of red drum age samples collected by fishery dependent and fishery independent sources on the Atlantic coast of the U.S. from 1981 – 2022.**



**Figure 9. Scatterplot of the length-at-age by stock/region for red drum collected on the Atlantic coast of the U.S. from 1981 – 2022.**

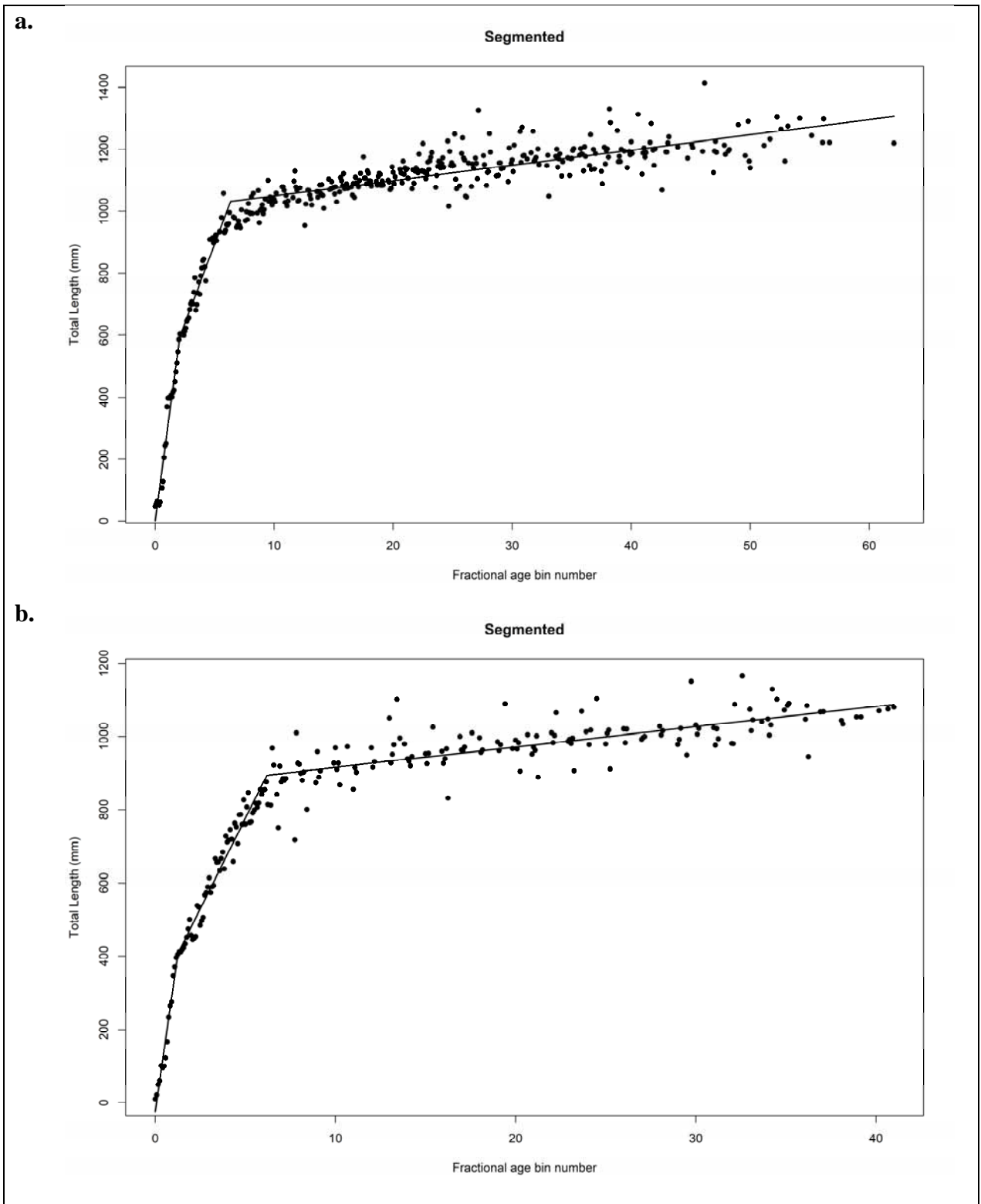
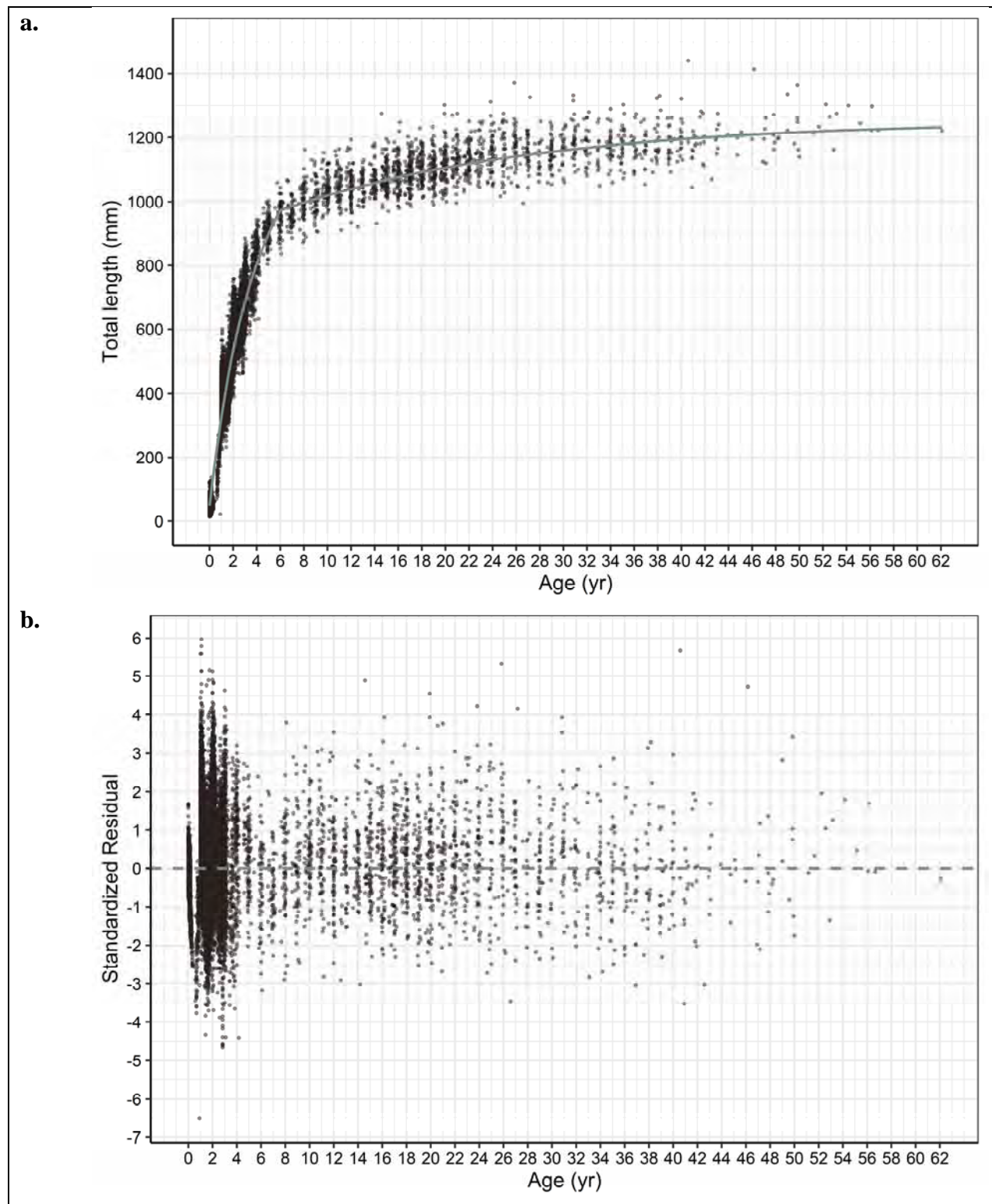


Figure 10. Segmented regression on red drum biological mean length-at-age by stock. (a) northern and (b) southern.



**Figure 11. Red drum length-at-age data collected from the northern stock of the Atlantic coast of the U.S. (a) the age-varying  $K$  growth model (blue line) as applied to the red drum length-at-age data and (b) the residuals from the model fit to the length-at-age data.**

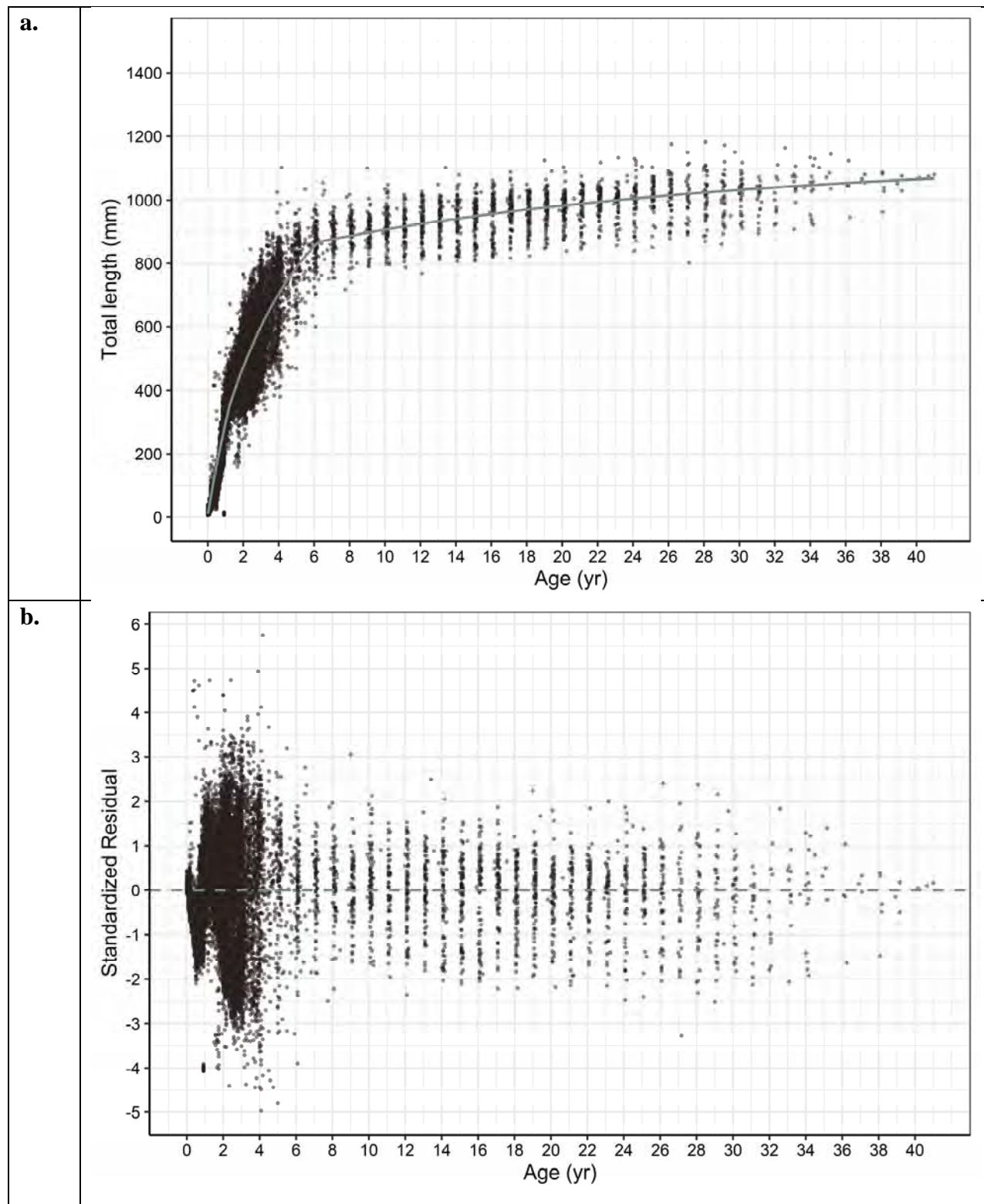


Figure 12. Red drum length-at-age data collected from the southern stock of the Atlantic coast of the U.S. (a) the age-varying  $K$  growth model (blue line) as applied to the red drum length-at-age data and (b) the residuals from the model fit to the length-at-age data.

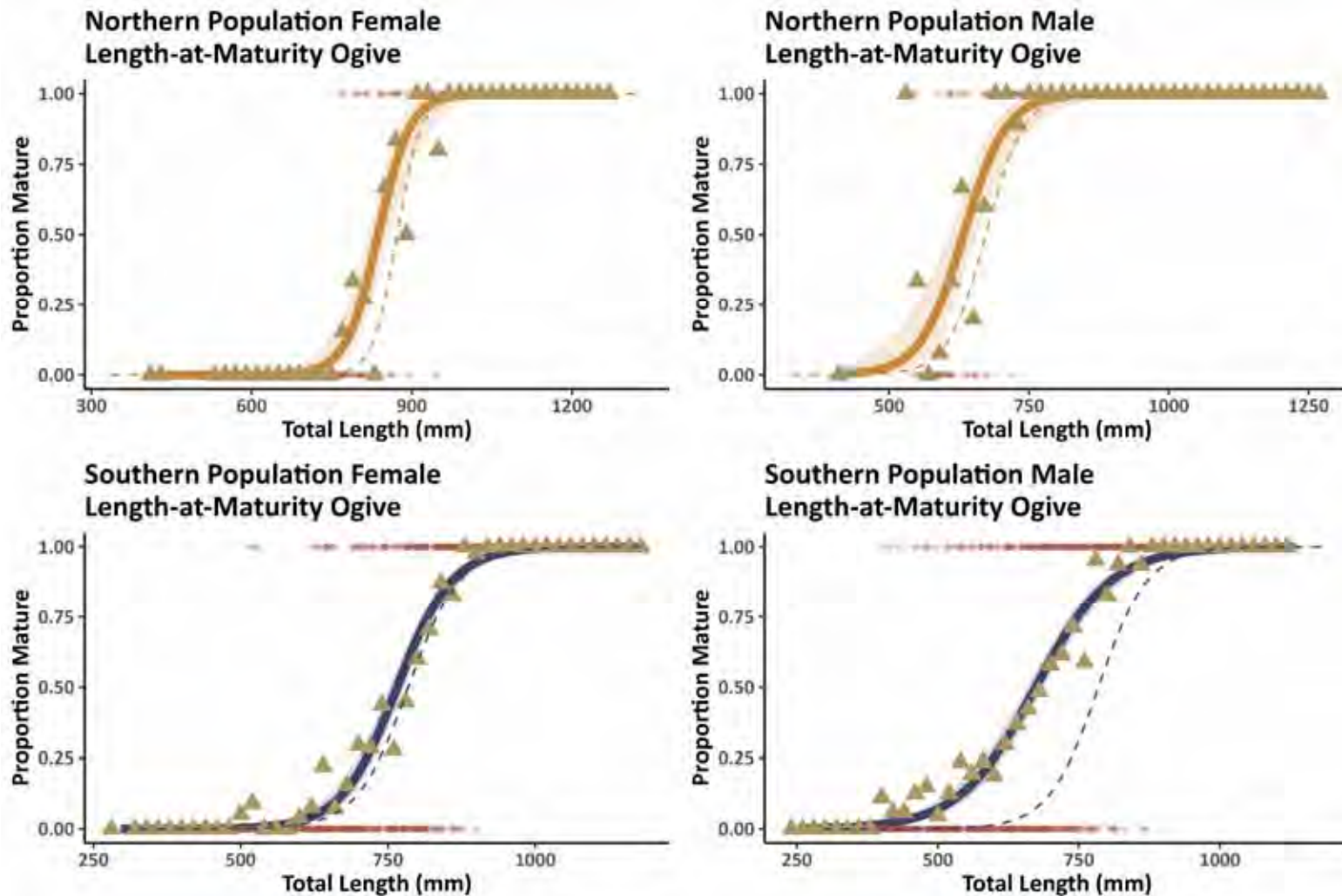


Figure 13. Best fit length-at-maturity ogives for female (left panels) and male (right panels) red drum from the southern (bottom panels; solid blue line) and northern (upper panels; solid orange line) stocks. Shaded regions represent 95% confidence interval about the ogive. Dashed lines are the maturity ogives presented in SEDAR 44. Red dots are maturity (0 = immature; 1 = mature) of individual fish and gold triangles represent observed proportion mature by 20 mm TL bin.

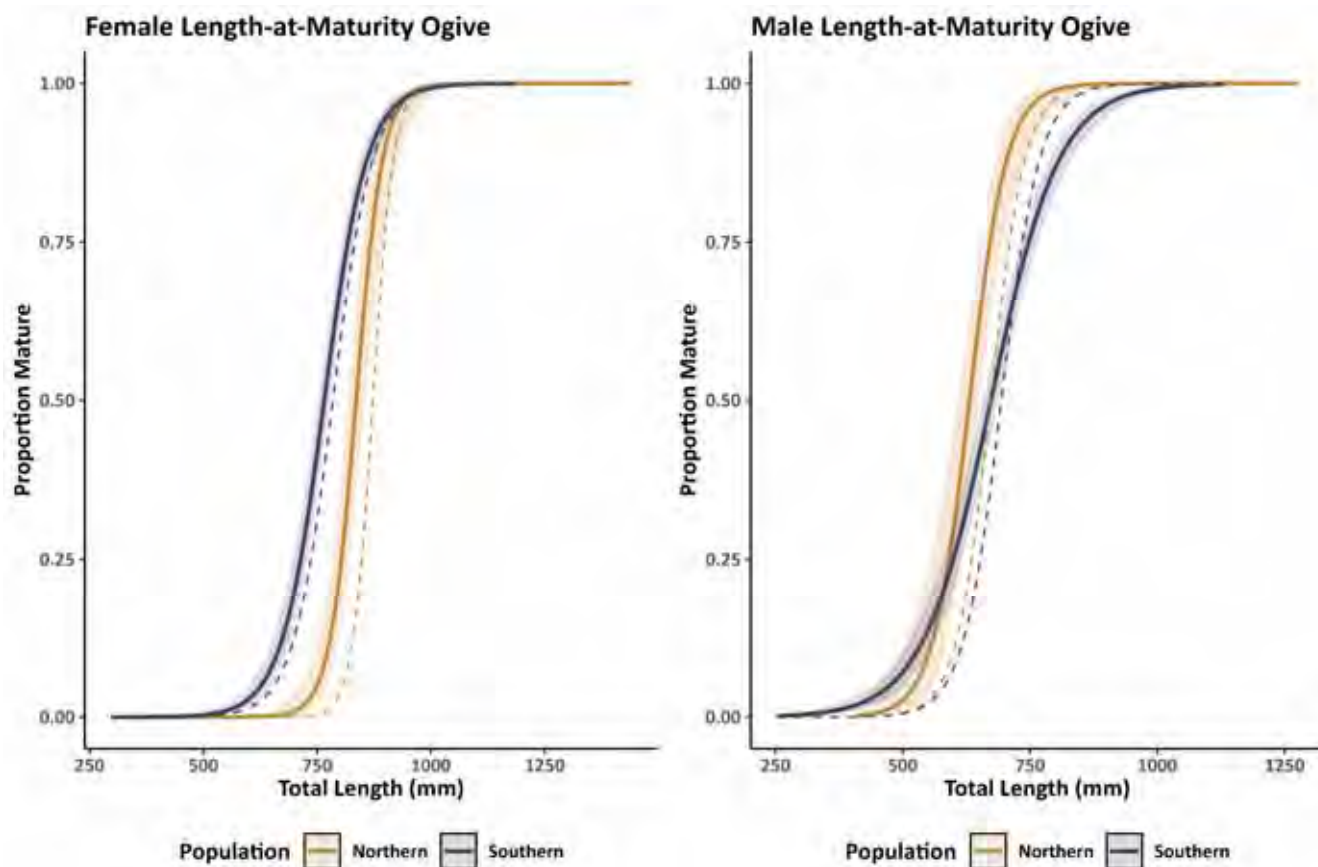


Figure 14. Best fit length-at-maturity ogives for female (left panel) and male (right panel) red drum from the southern (solid blue line) and northern (solid orange line) stocks. Shaded regions represent 95% confidence interval about the ogive. Dashed lines are the maturity ogives presented in SEDAR 44.

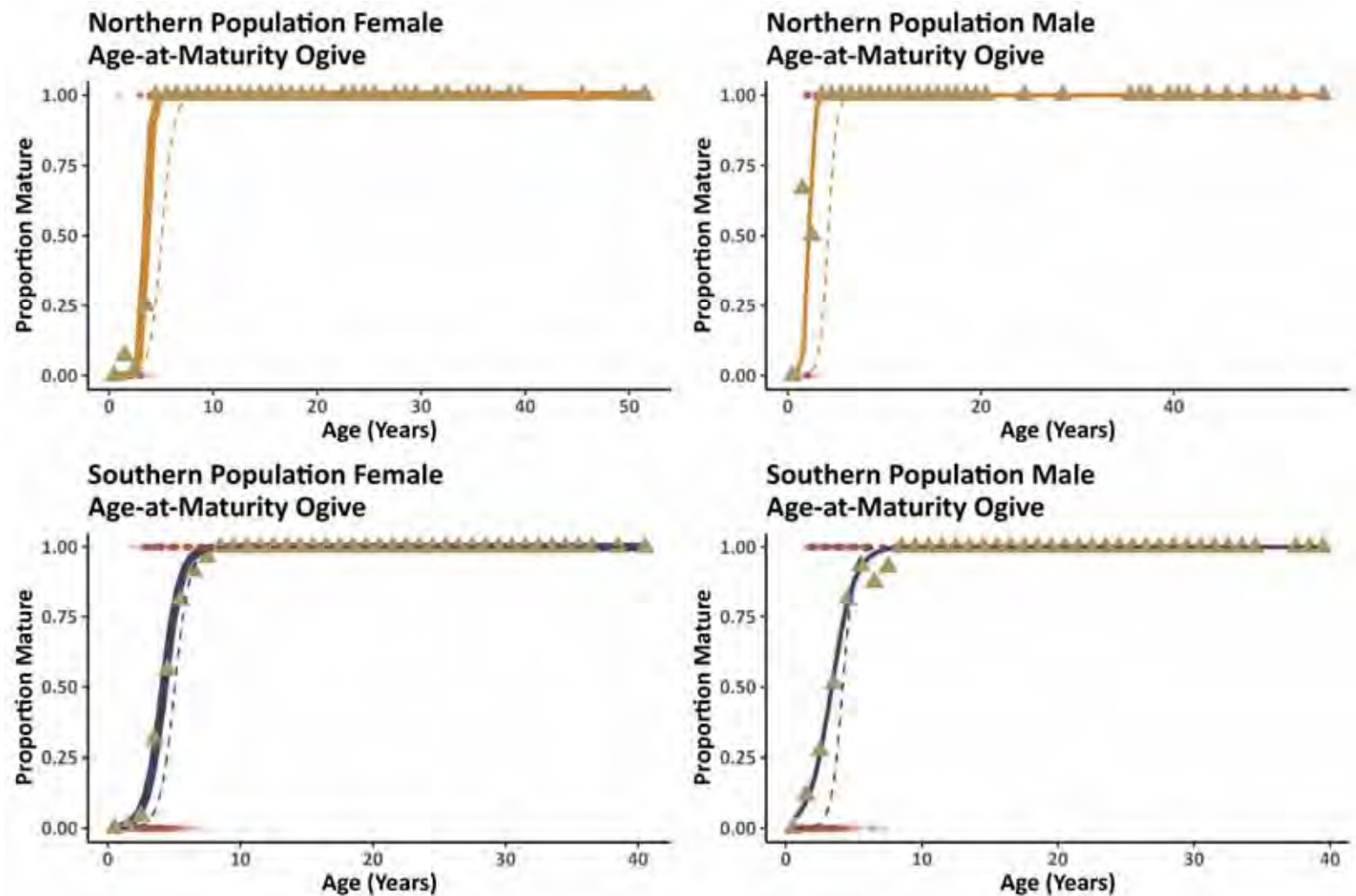


Figure 15. Best fit age-at-maturity ogives for female (left panels) and male (right panels) red drum from the southern (bottom panels; solid blue line) and northern (upper panels; solid orange line) stocks. Shaded regions represent 95% confidence interval about the ogive. Dashed lines are the maturity ogives presented in SEDAR 44. Red dots are maturity (0 = immature; 1 = mature) of individual fish and gold triangles represent observed proportion mature by age bin.

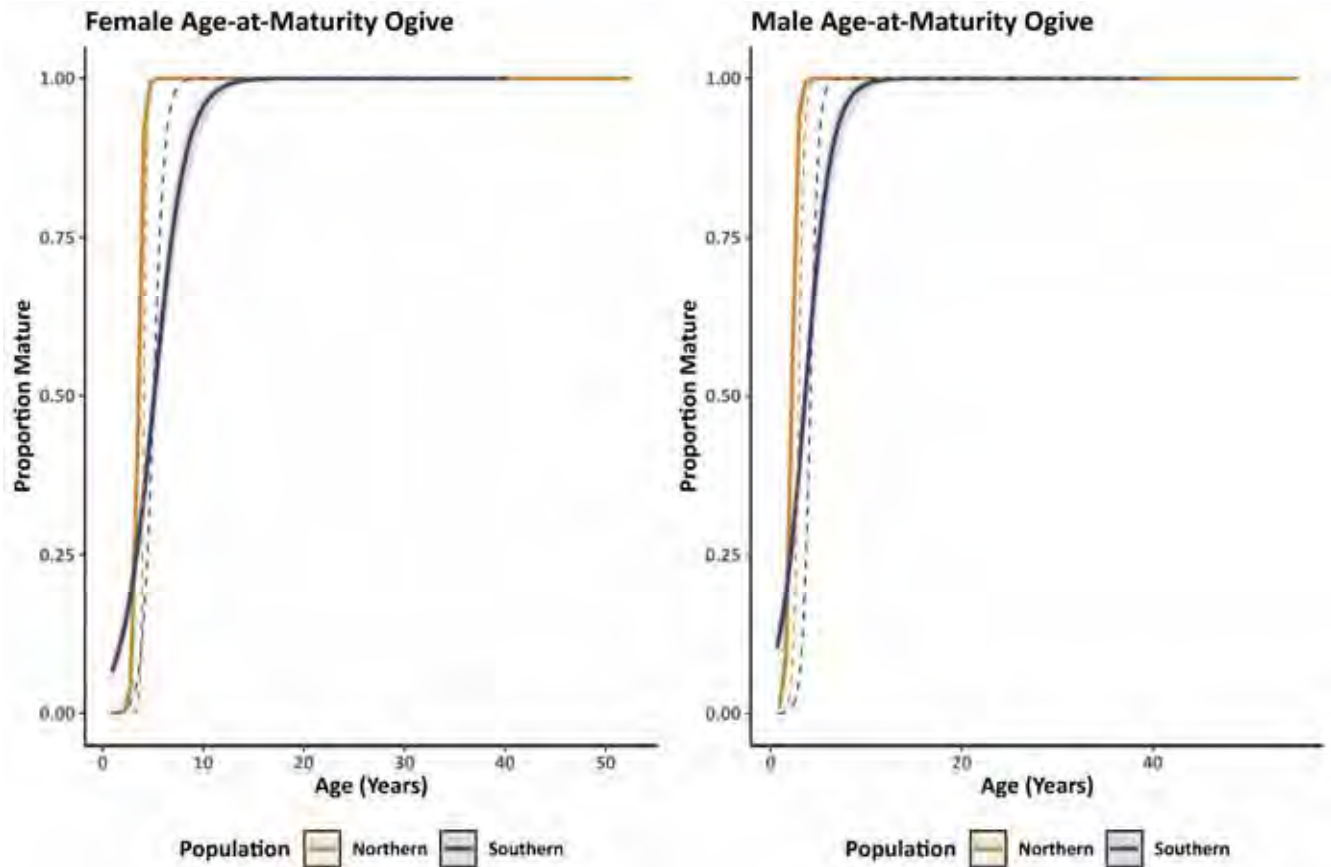


Figure 16. Best fit age-at-maturity ogives for female (left panel) and male (right panel) red drum from the southern (solid blue line) and northern (solid orange line) stocks. Shaded regions represent 95% confidence interval about the ogive. Dashed lines are the maturity ogives presented in SEDAR 44.



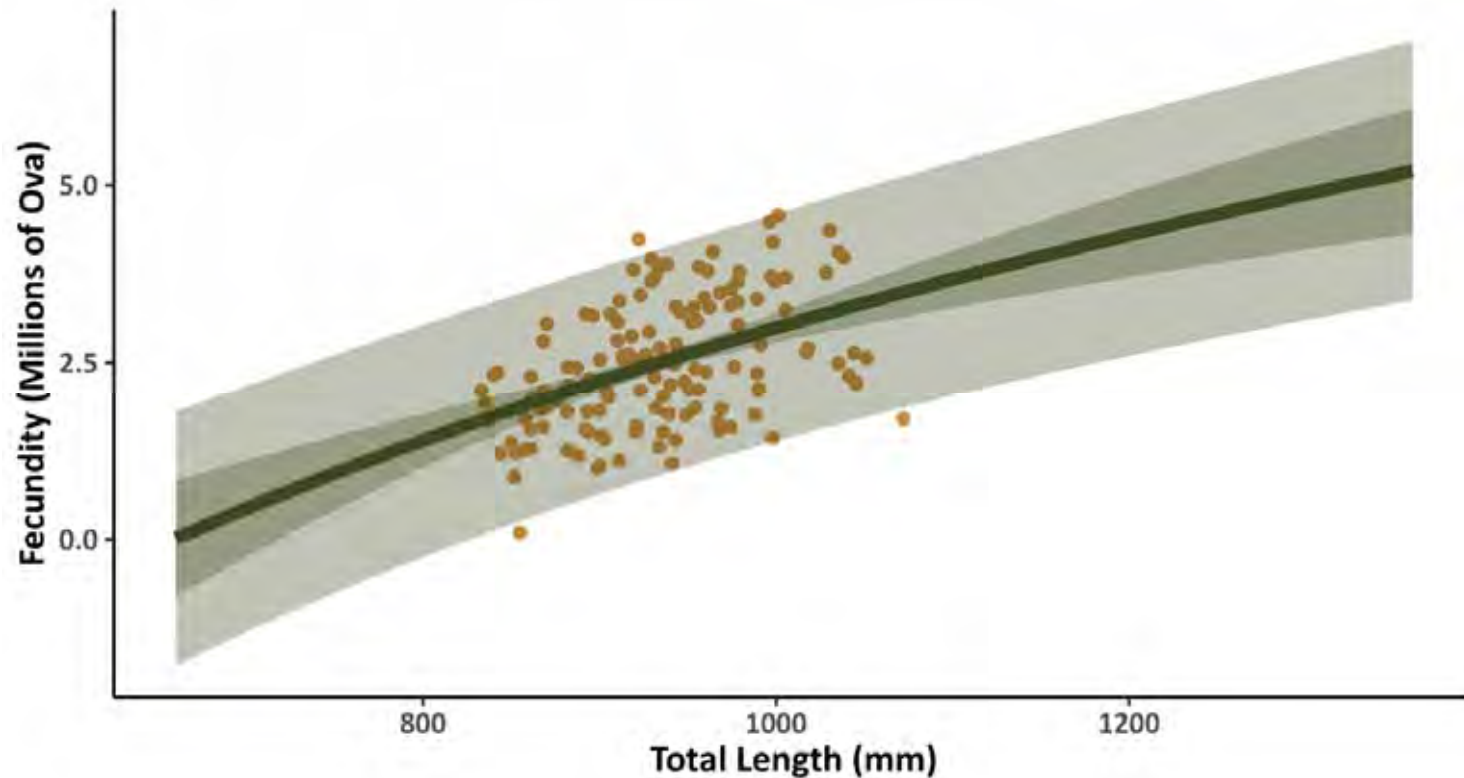
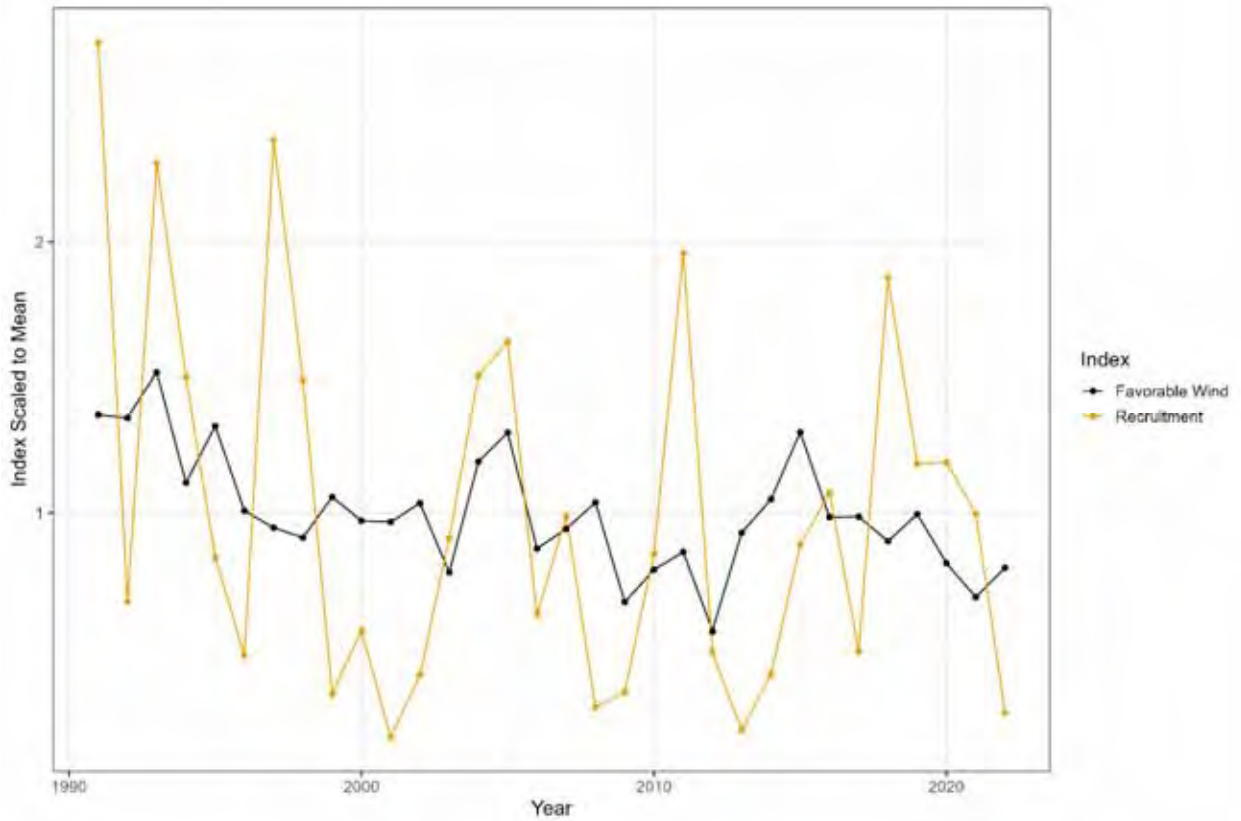
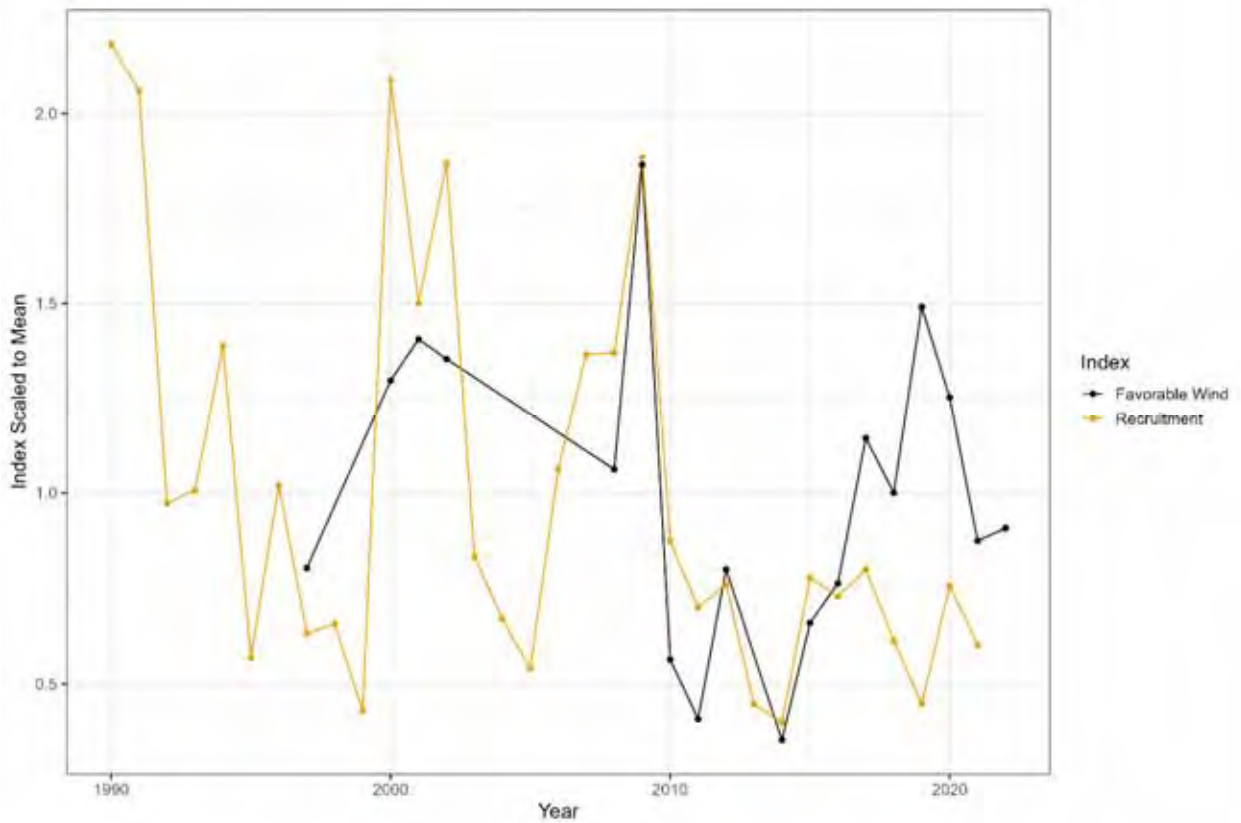


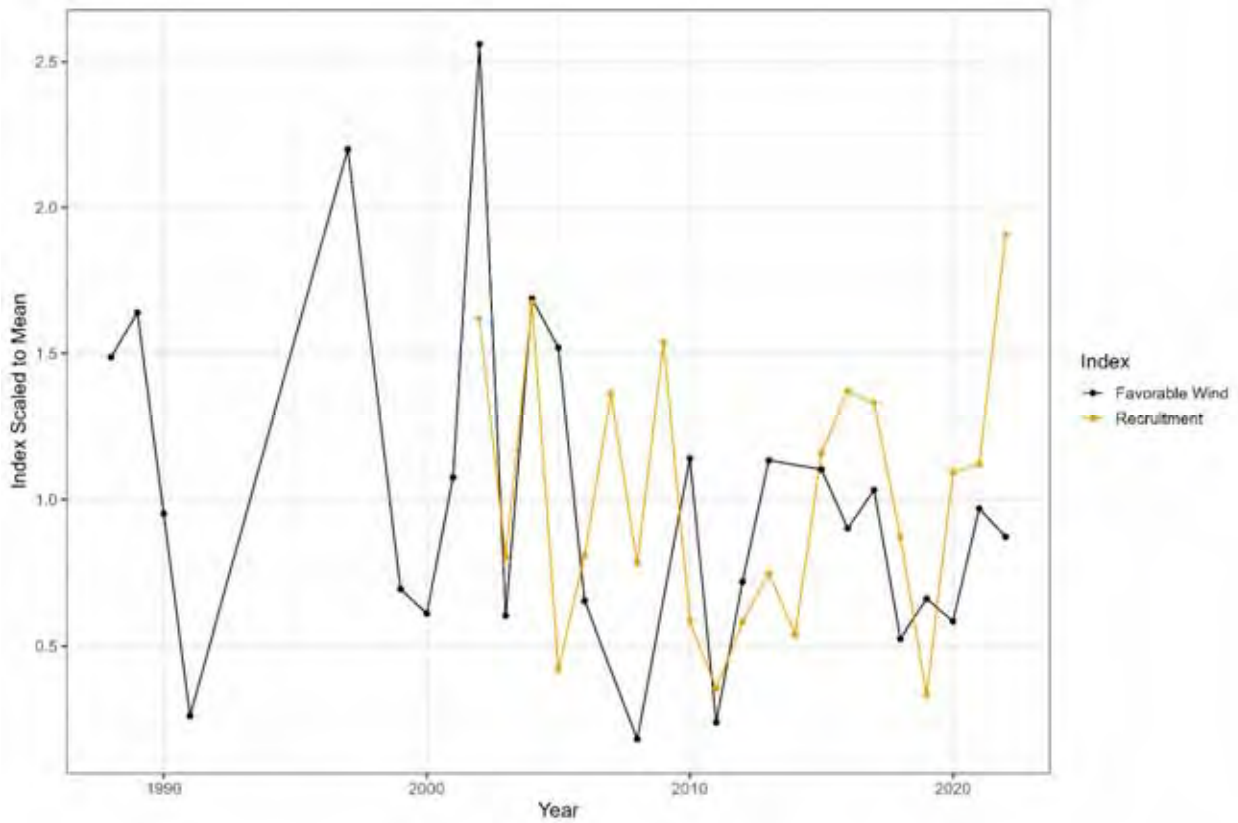
Figure 17. Batch fecundity estimates of female red drum based on the FWRI data set available from Tampa Bay, FL (orange dots) along with a fitted linear regression model (green line) and 95% confidence intervals (dark shaded region) and 95% prediction intervals (light shaded region) for the range of sizes with positive fecundity estimates (based on the model) and non-zero probability of a female being mature based on the Atlantic southern stock length-at-maturity ogive developed for this assessment.



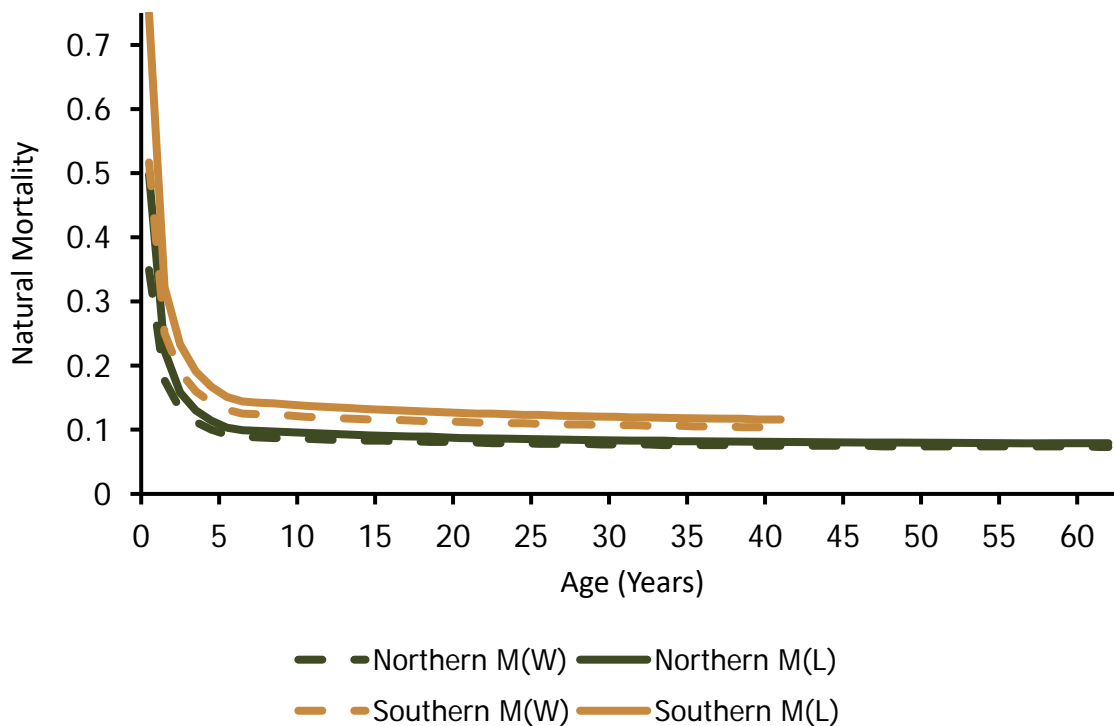
**Figure 18. North Carolina Bag Seine Survey recruitment index and seasonal favorable wind index from North Carolina State Climate Office station KHSE.**



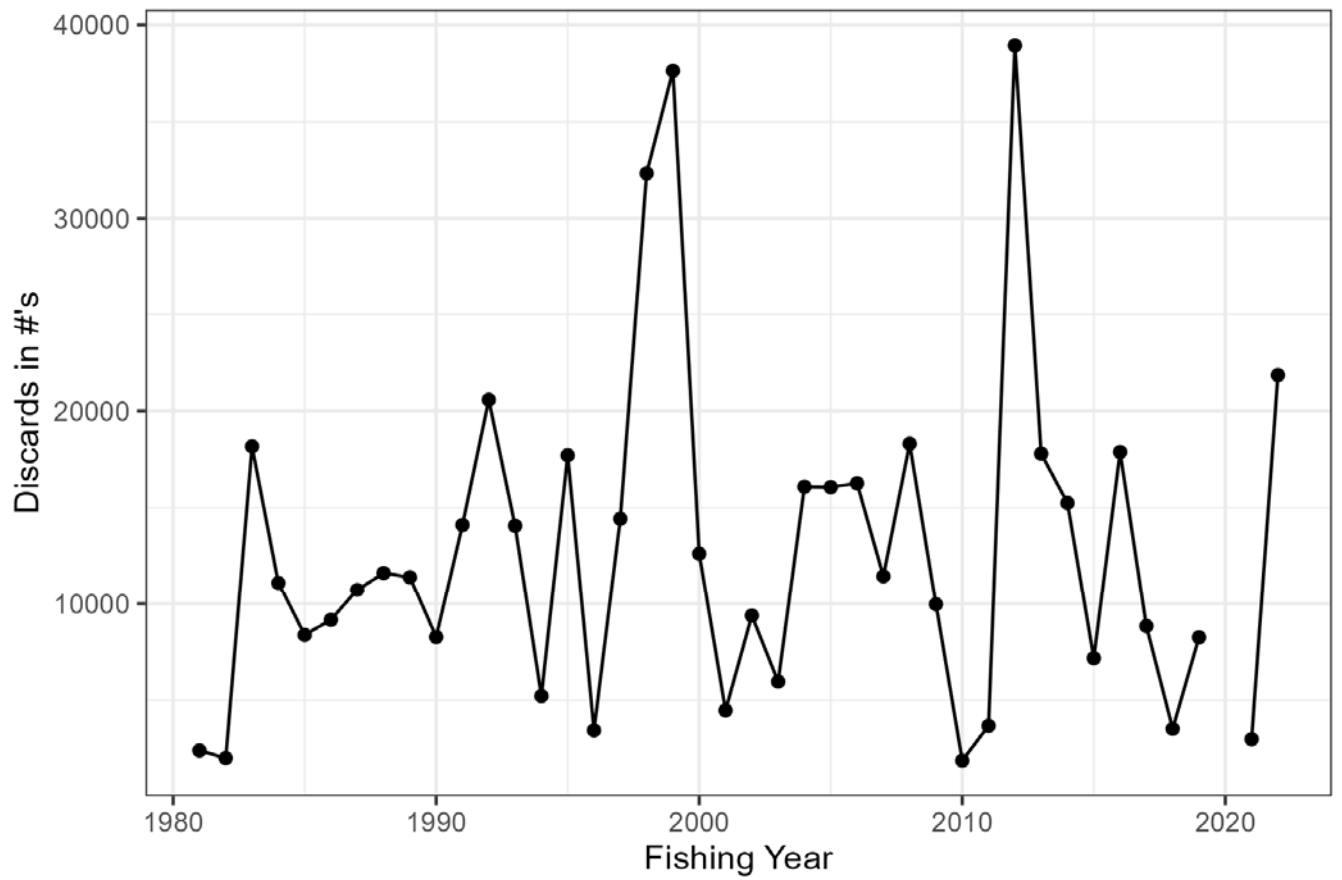
**Figure 19. South Carolina Trammel Net Survey age-1 index lagged back one year and early September favorable wind index from NOAA National Data Buoy Center Station 41004 southeast of Charleston.**



**Figure 20. Georgia Gill Net Survey age-0 fishing year index and early August favorable wind index from NOAA National Data Buoy Center Station 41008 southeast of Savannah.**



**Figure 21. Northern (green lines) and southern (gold lines) externally derived natural mortality estimates based on stock-specific maximum age and either weight-based M-at-age (dashed lines; Lorenzen 1996) or length-based M-at-age (solid lines; Lorenzen 2022).**



**Figure 22. Estimated red drum discards in numbers based on North Carolina estuarine gill net observer program.**

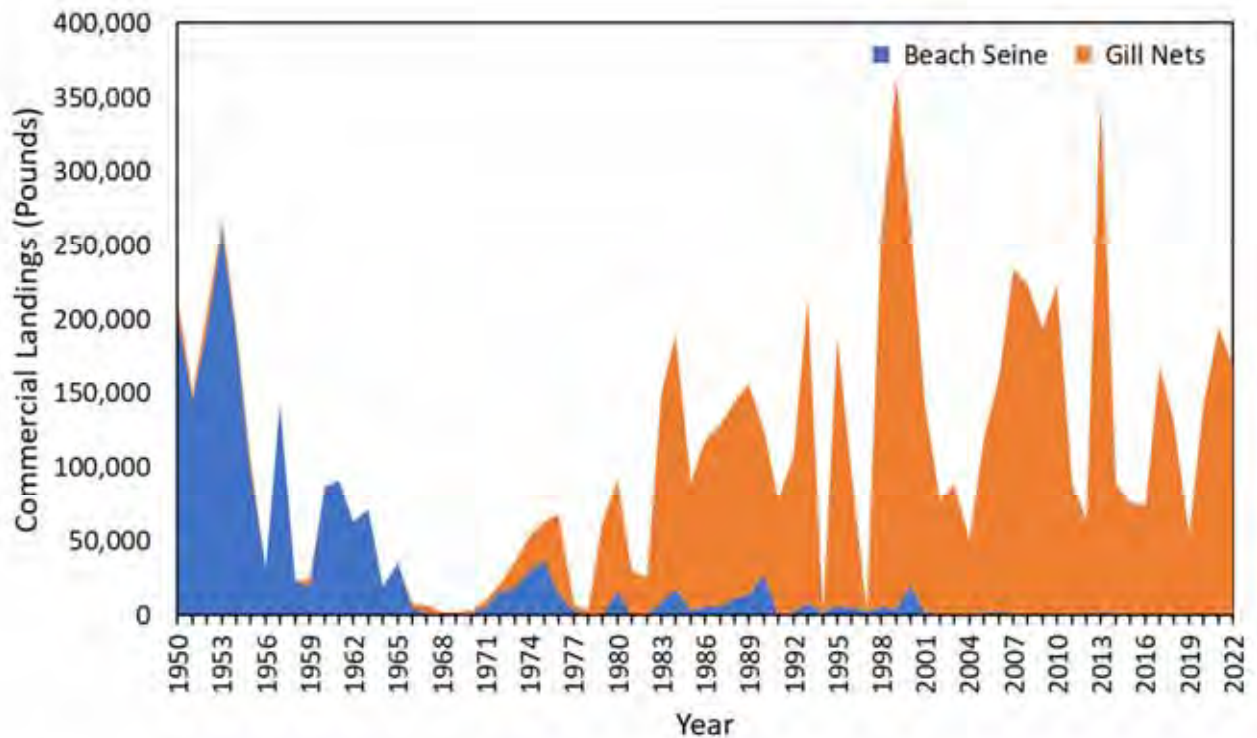


Figure 23. Total commercial landings of northern stock red drum by the commercial gill net and beach seine (GNBS) fleet. Confidential data have been removed from the data set.

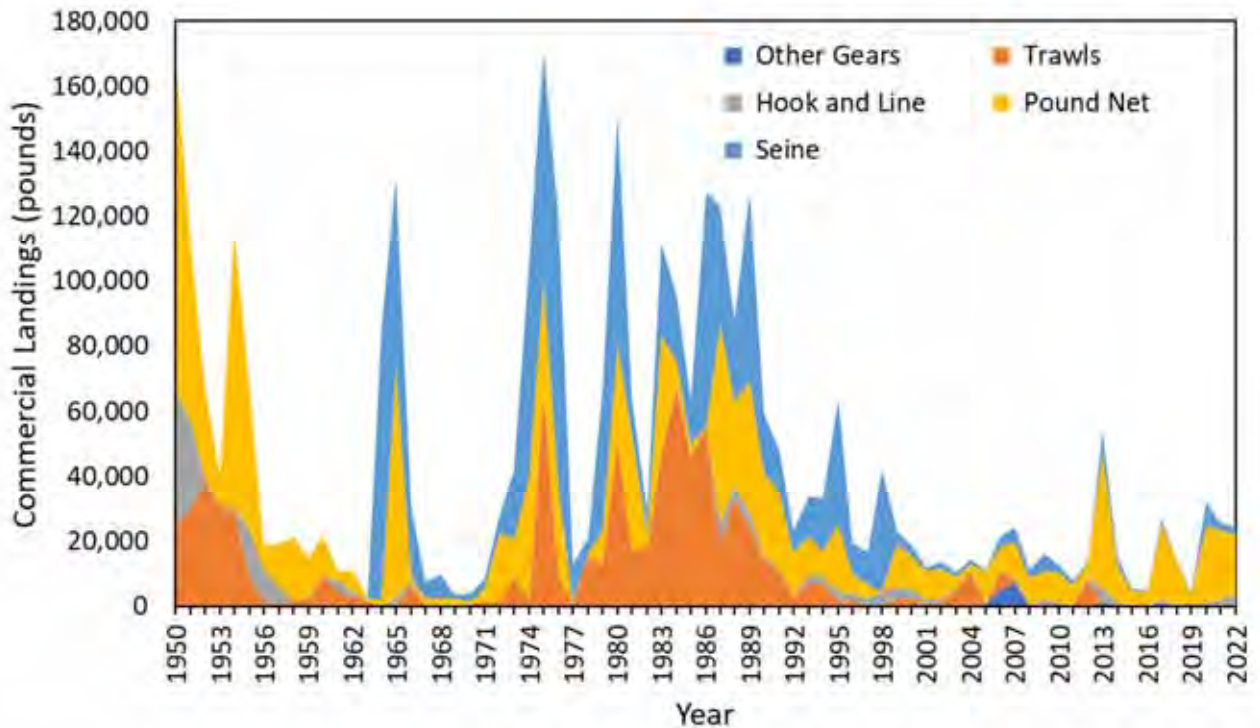


Figure 24. Total commercial landings of northern stock red drum by the commercial other gear fleet. Confidential data have been removed from the data set.

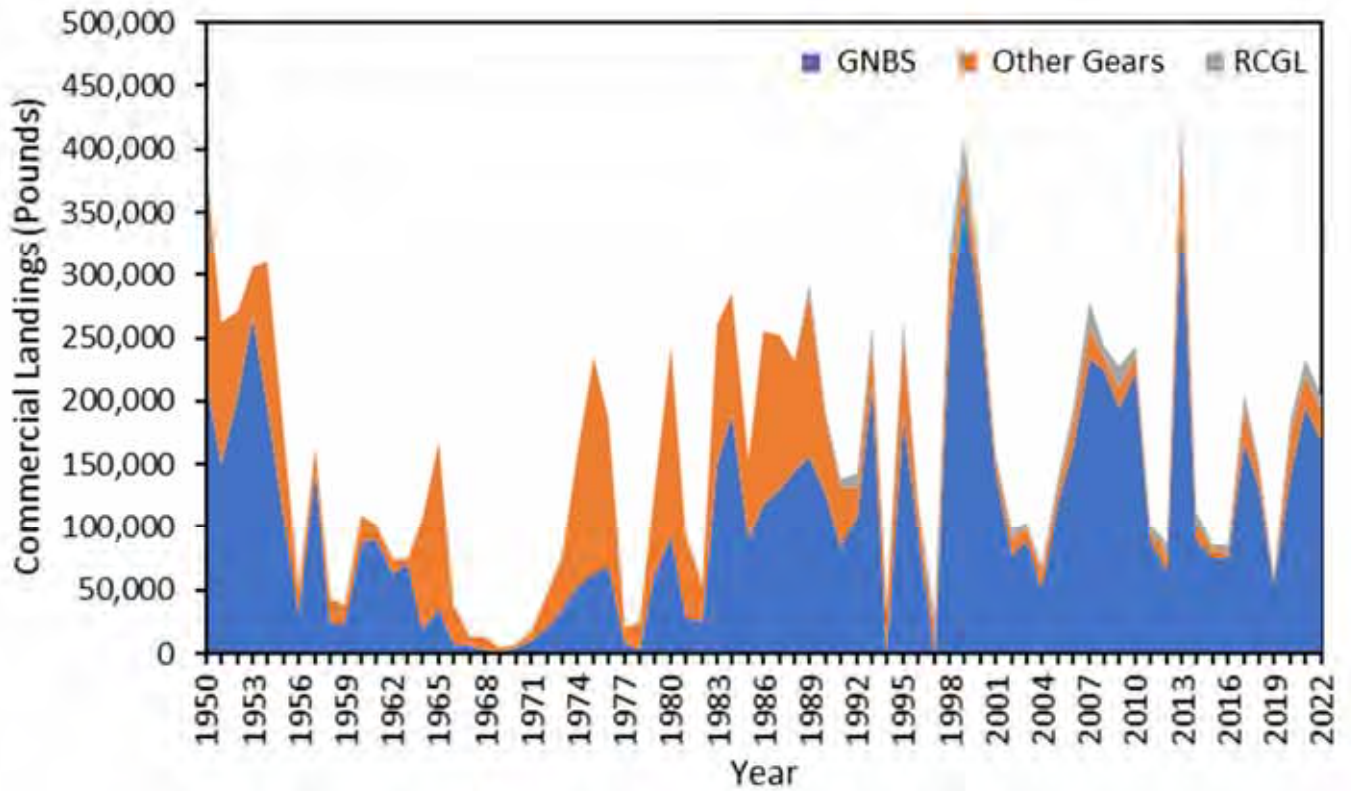


Figure 25. Total commercial landings of northern stock red drum. Confidential data have been removed from the data set.

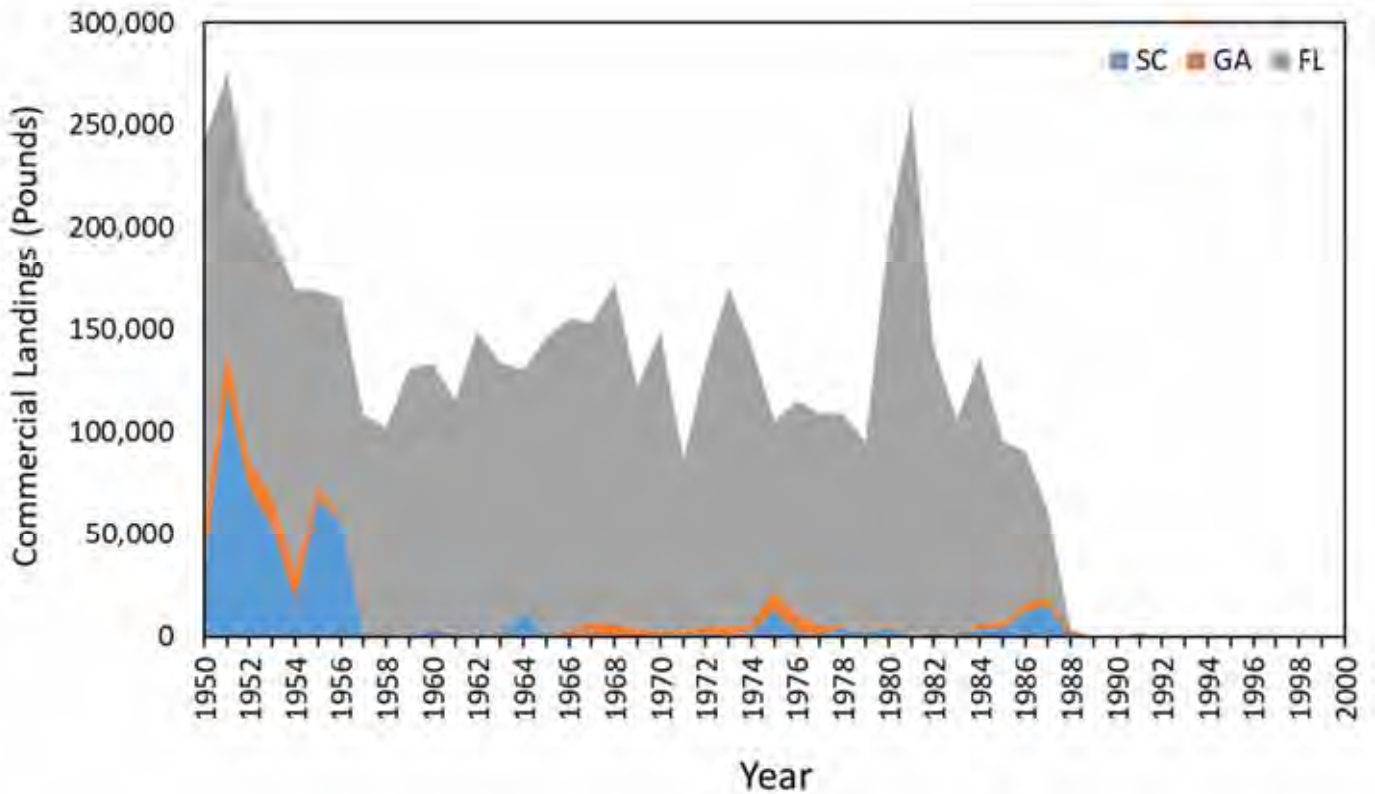
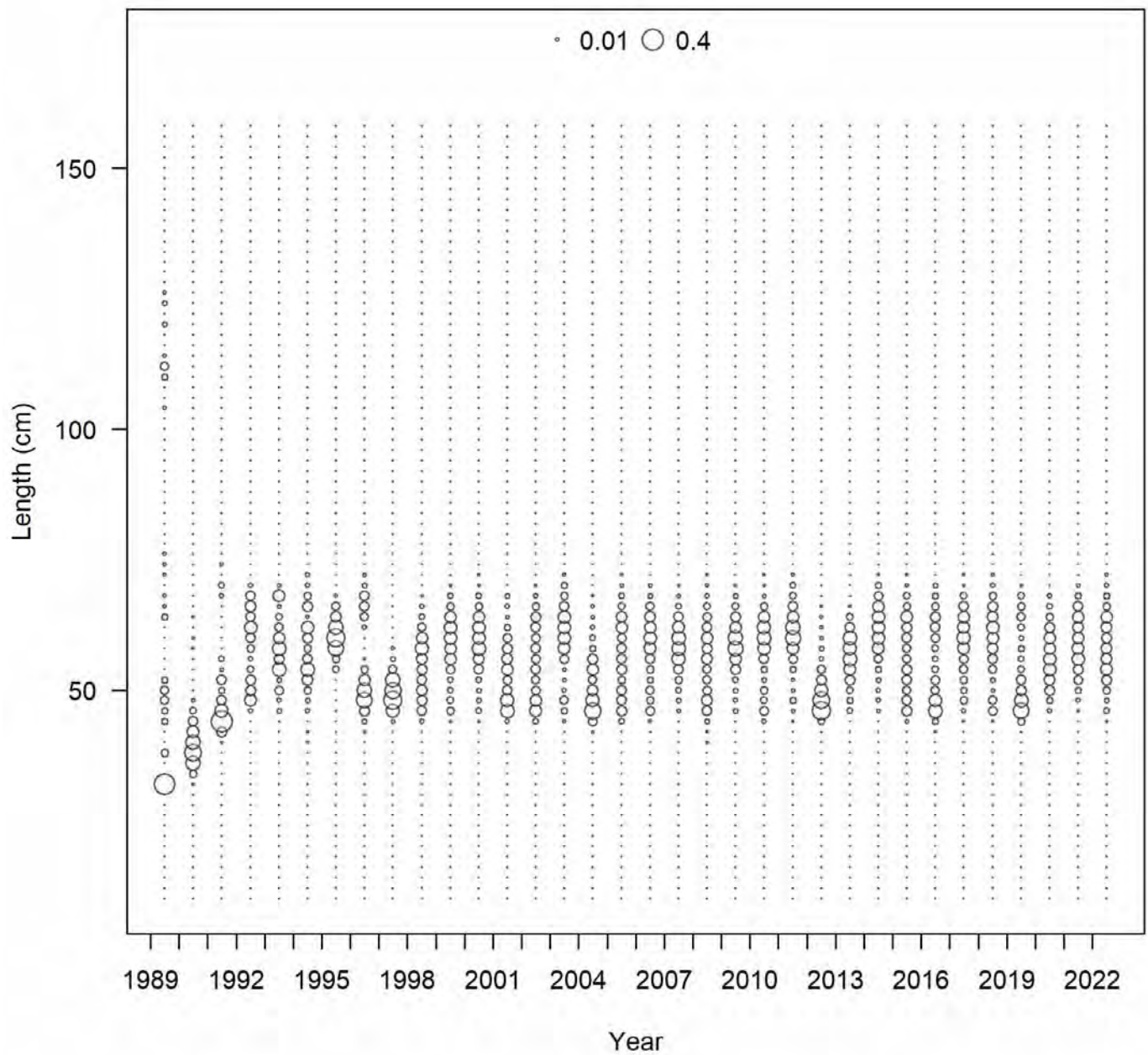
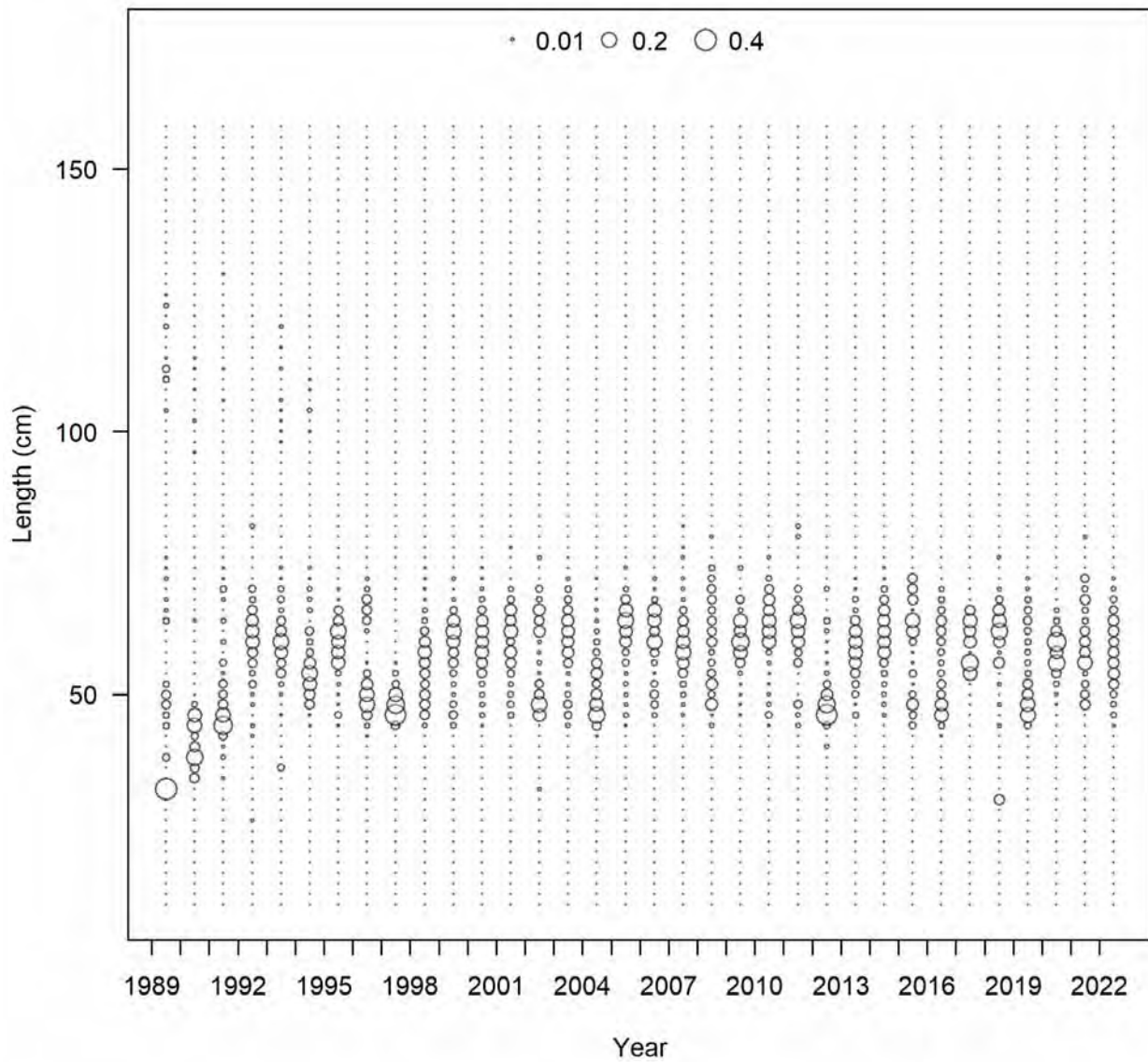


Figure 26. Total commercial landings of southern stock red drum. Confidential data have been removed from the data set.



**Figure 27. Annual length distributions of red drum landed by the North\_Commercial\_GNBS fleet.**



**Figure 28. Annual length distributions of red drum landed by the North\_Commercial\_Other fleet.**



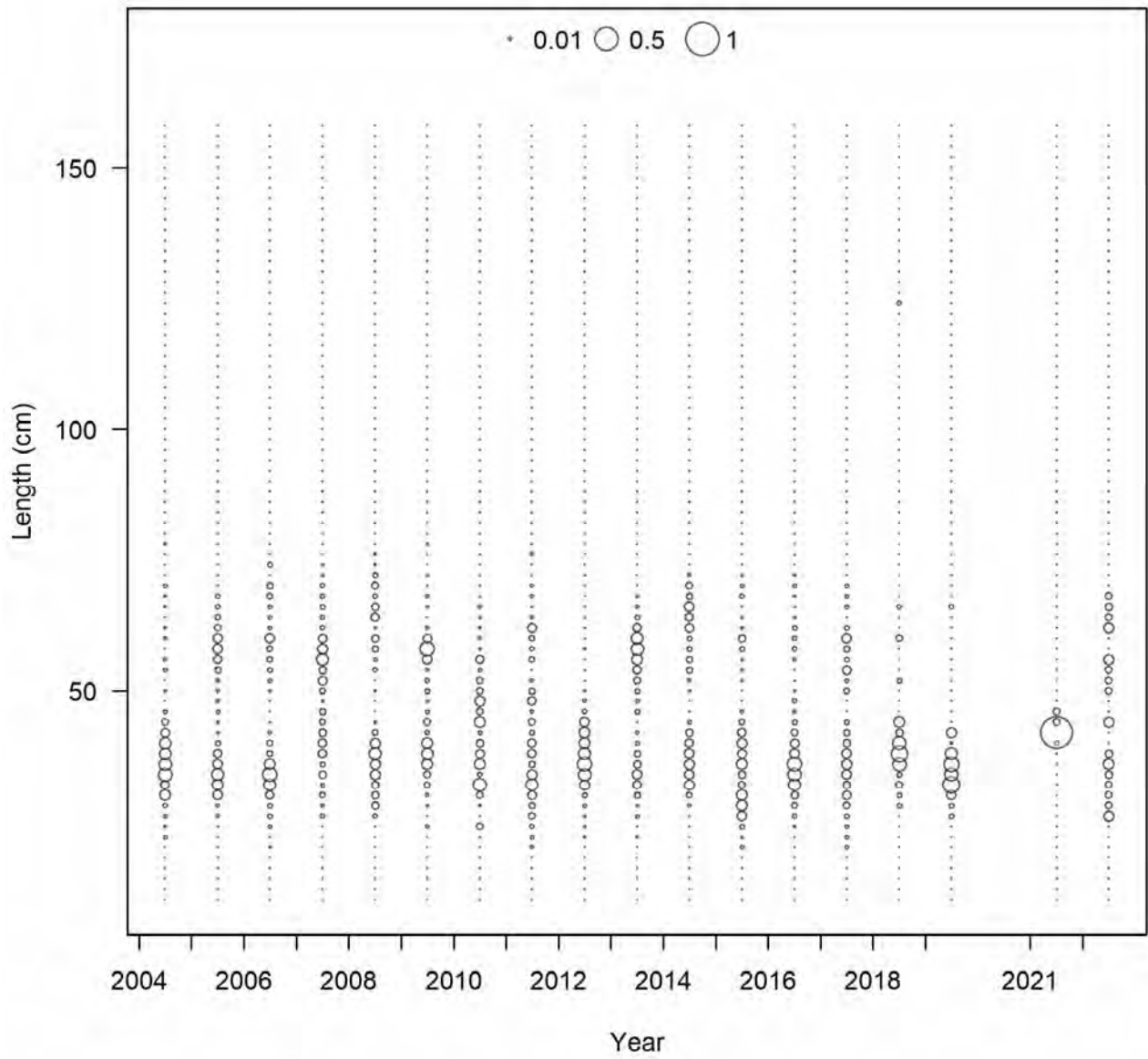
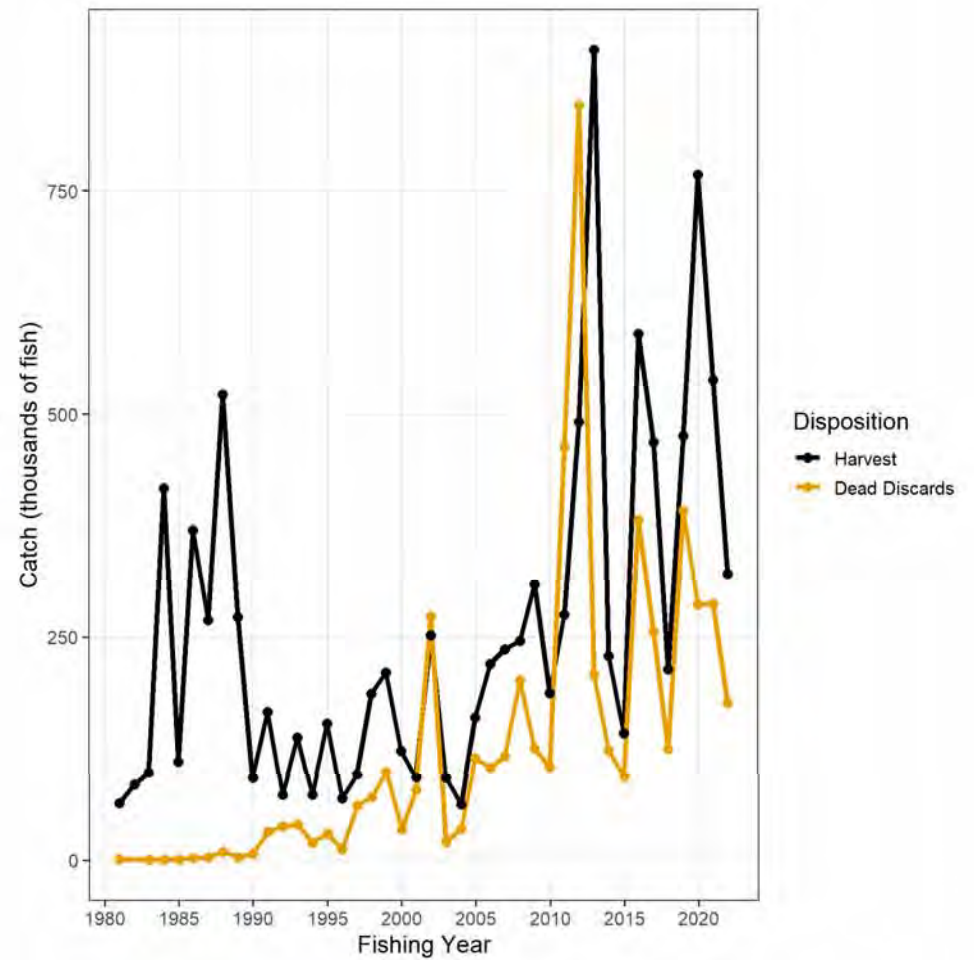
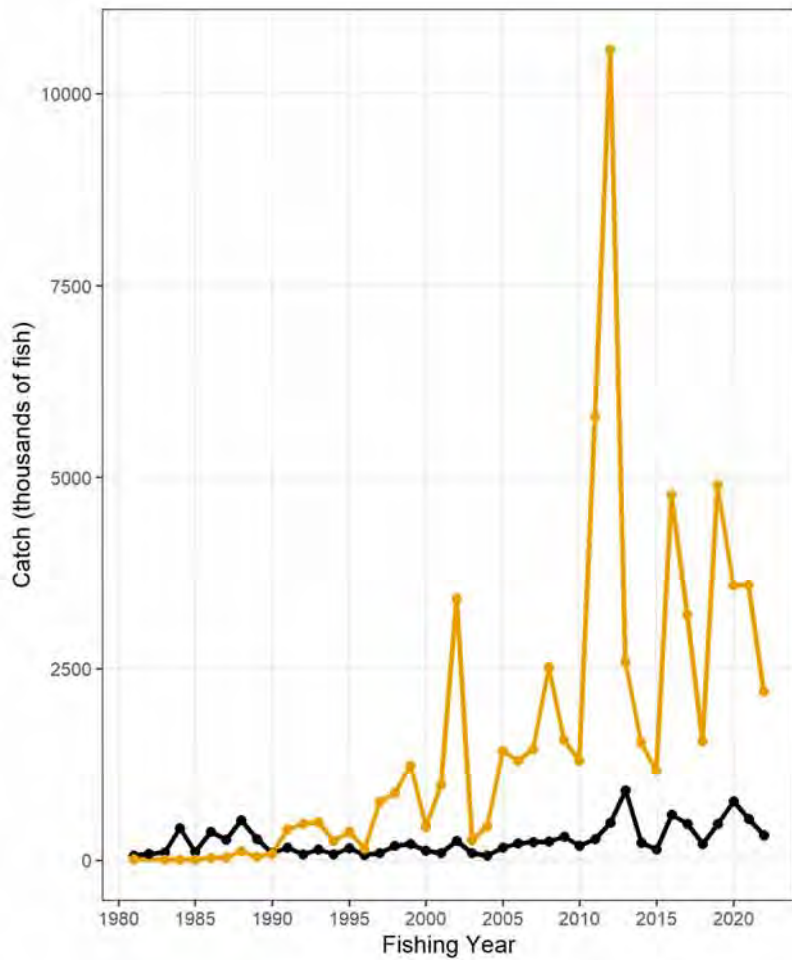


Figure 29. Annual length distributions of red drum discarded by the North Commercial GNBS fleet.



**Figure 30. MRIP recreational catch estimates of red drum from the northern stock. Dead discards are calculated with an assumed 8% discard mortality of releases. \*\*2022 data are preliminary.**

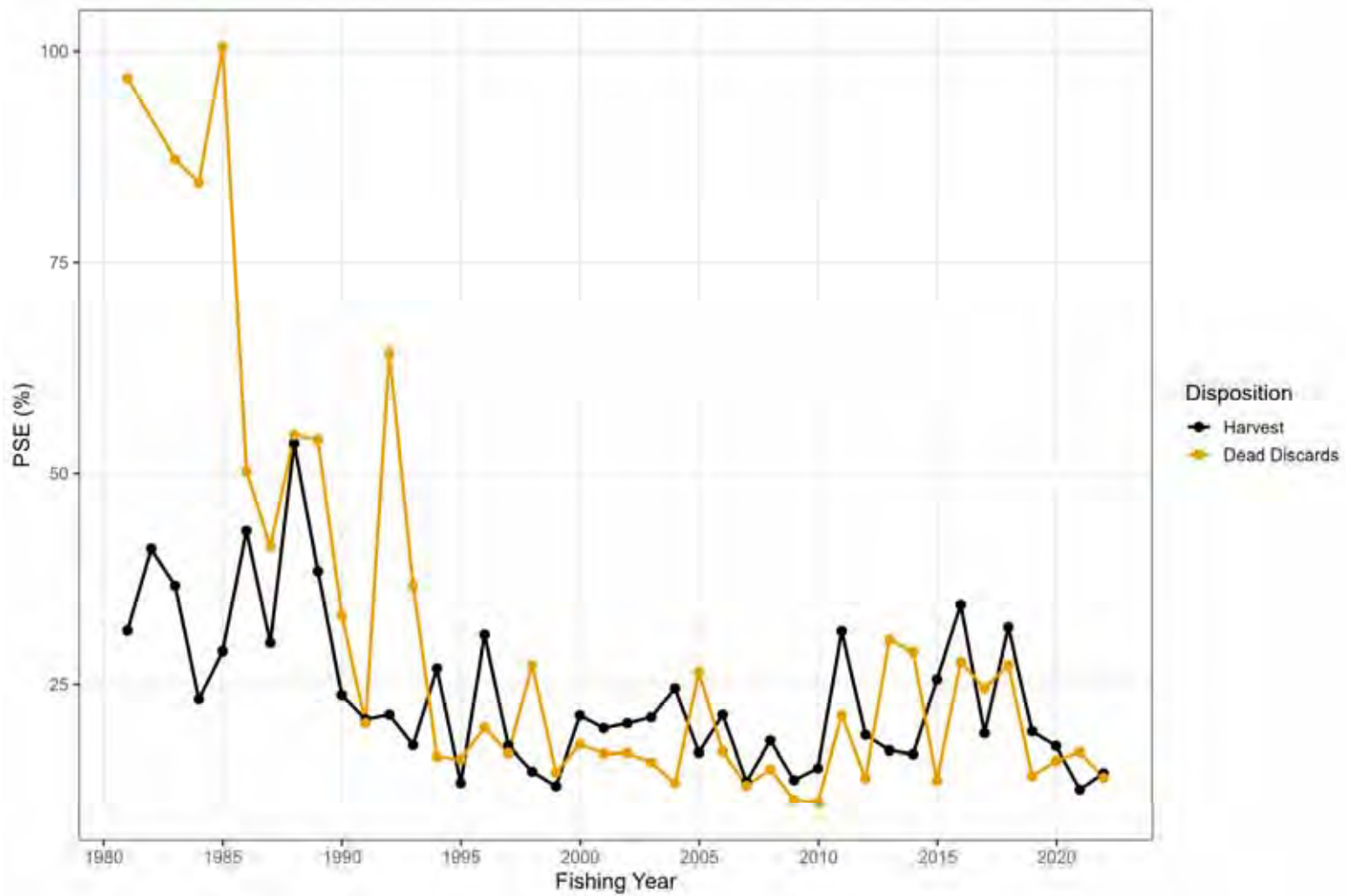
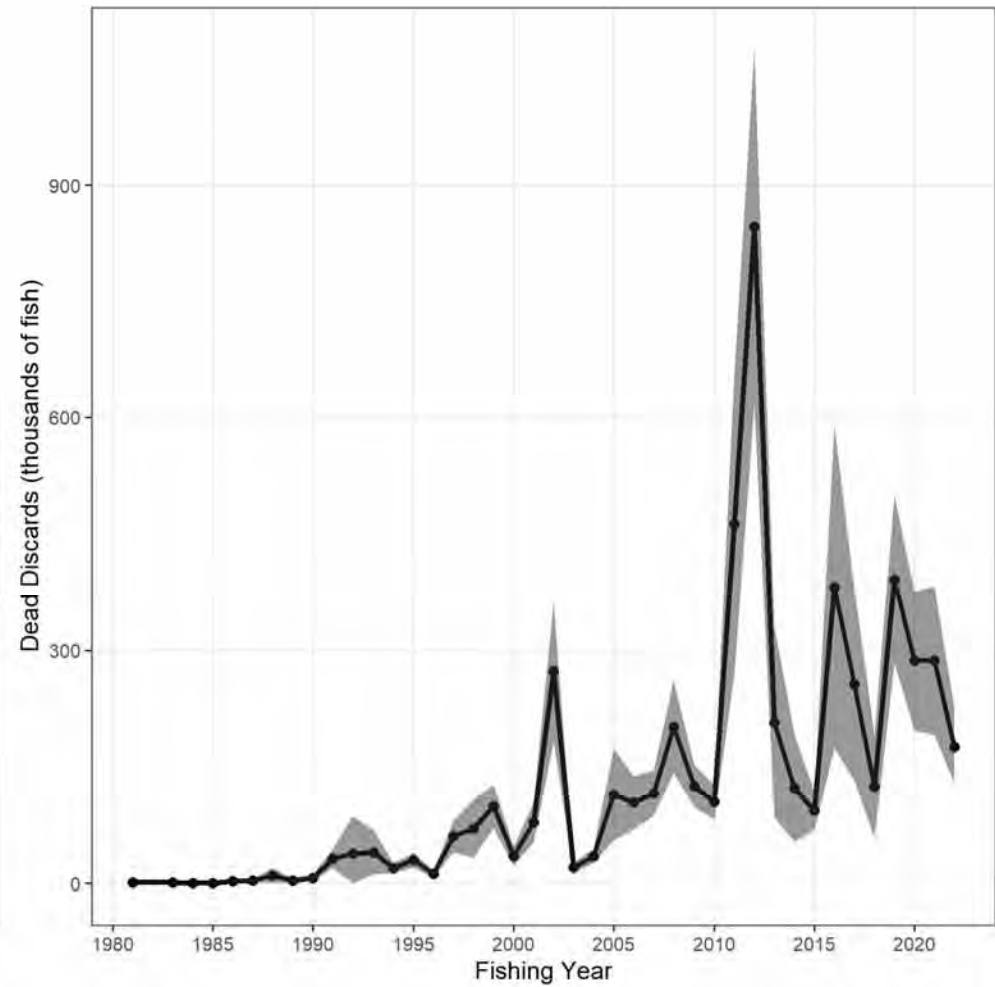
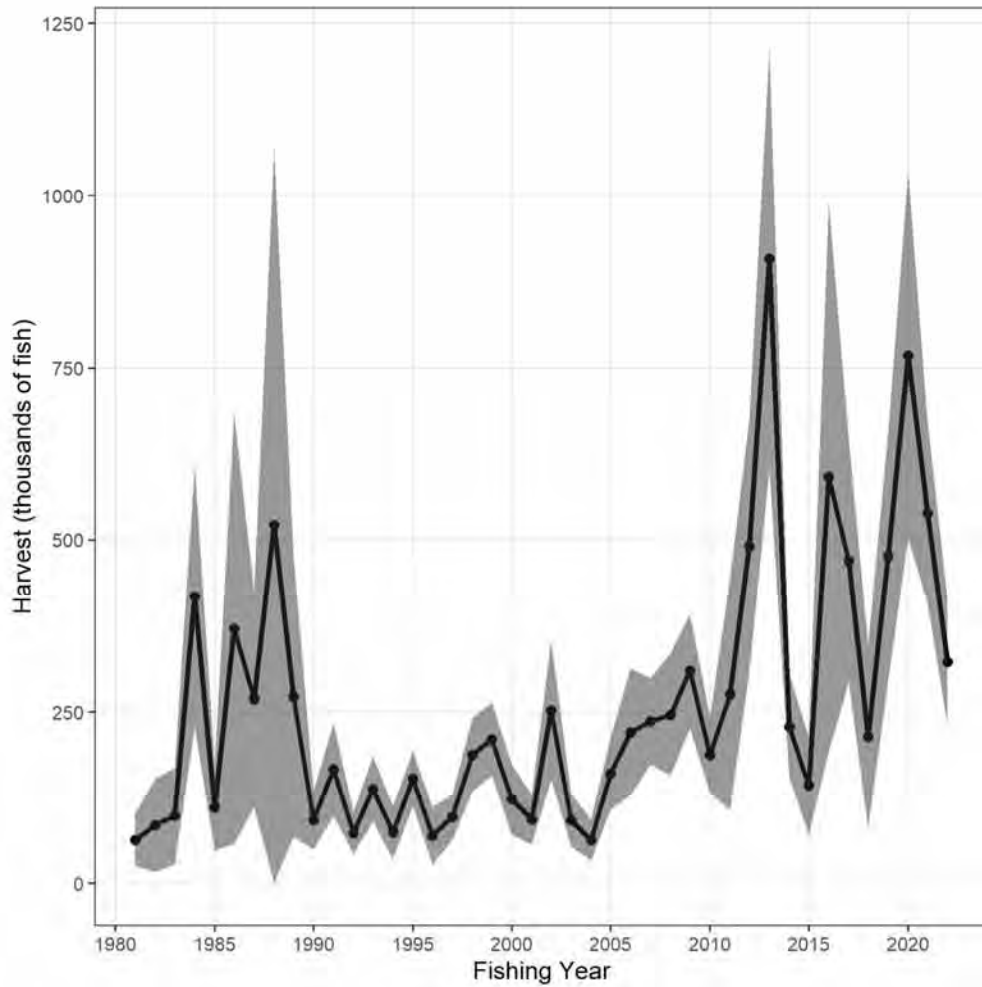


Figure 31. Proportional standard error of MRIP recreational catch estimates of red drum from the northern stock. \*\*2022 data are preliminary.



**Figure 32. MRIP recreational catch estimates of red drum from the northern stock with 95% confidence intervals (shaded regions). Dead discards are calculated with an assumed 8% discard mortality of releases and confidence intervals are calculated assuming the same PSEs as for released alive estimates. \*\*2022 data are preliminary.**

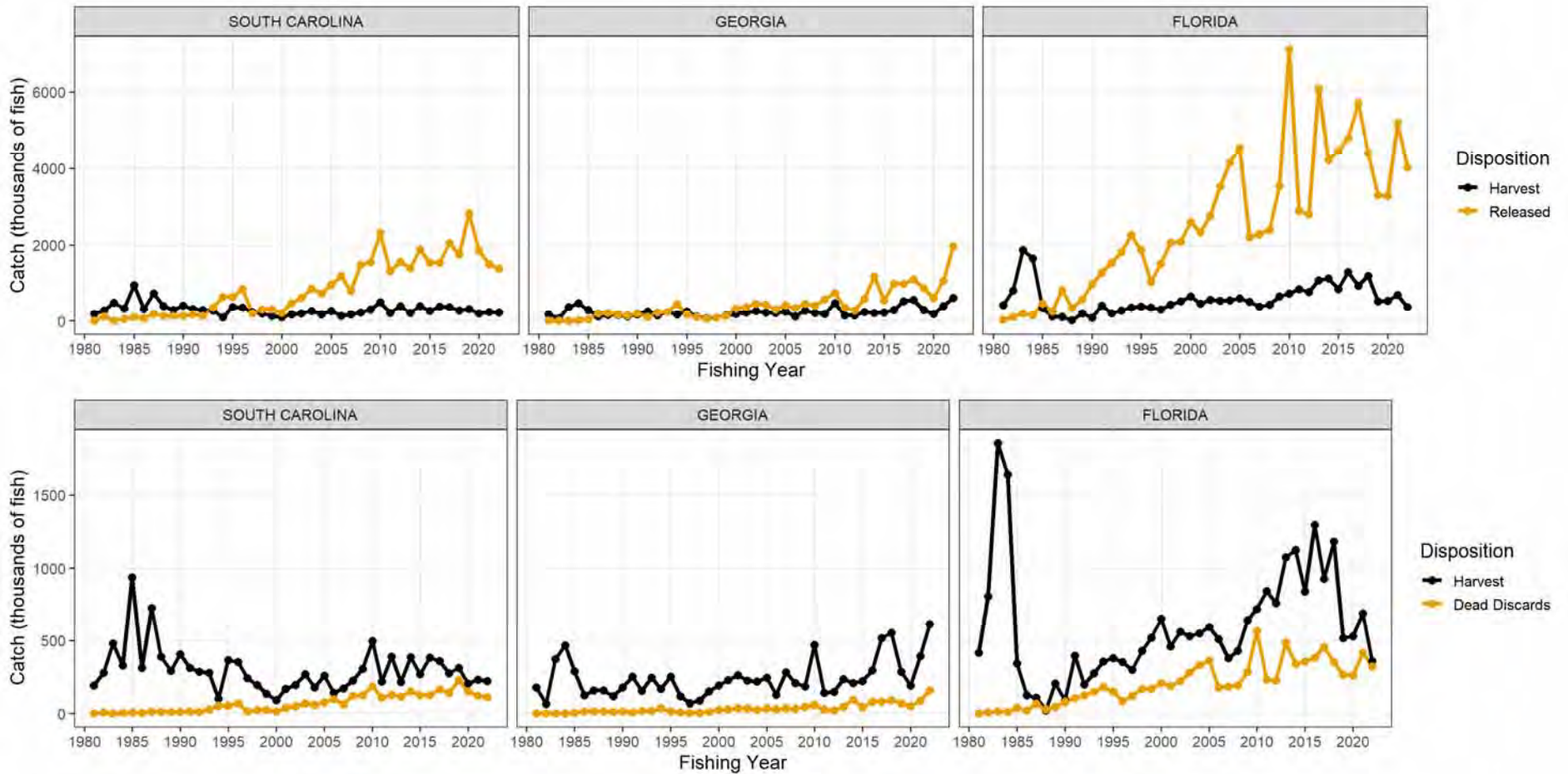
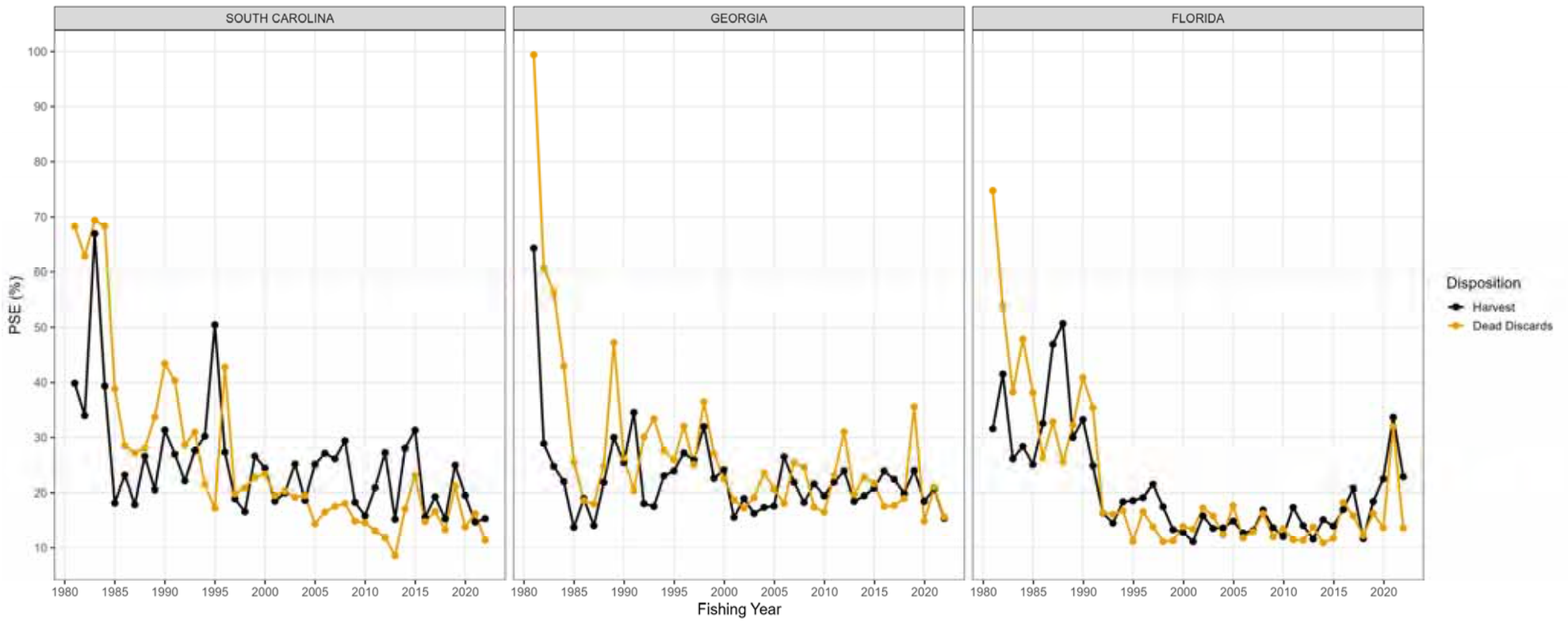
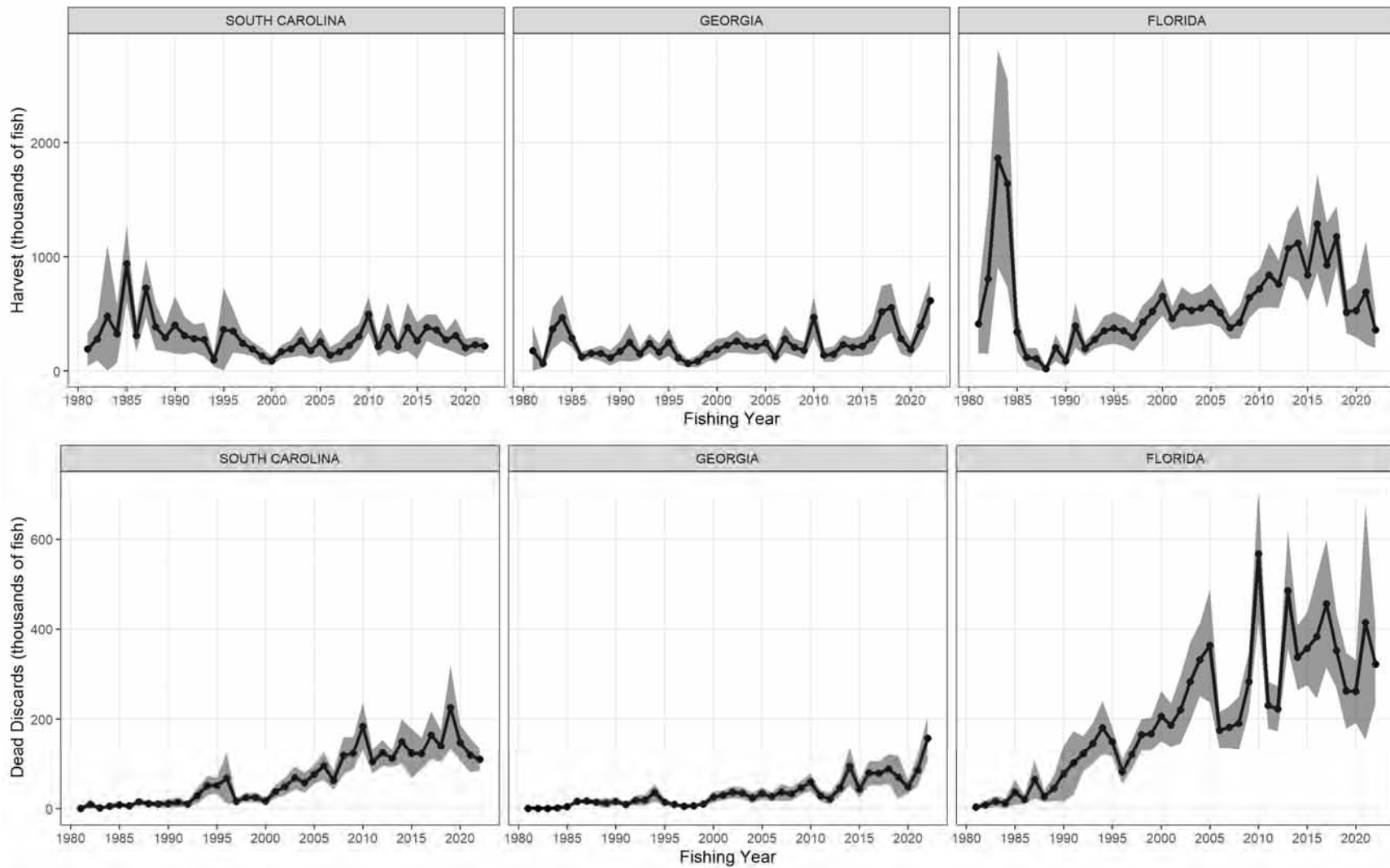


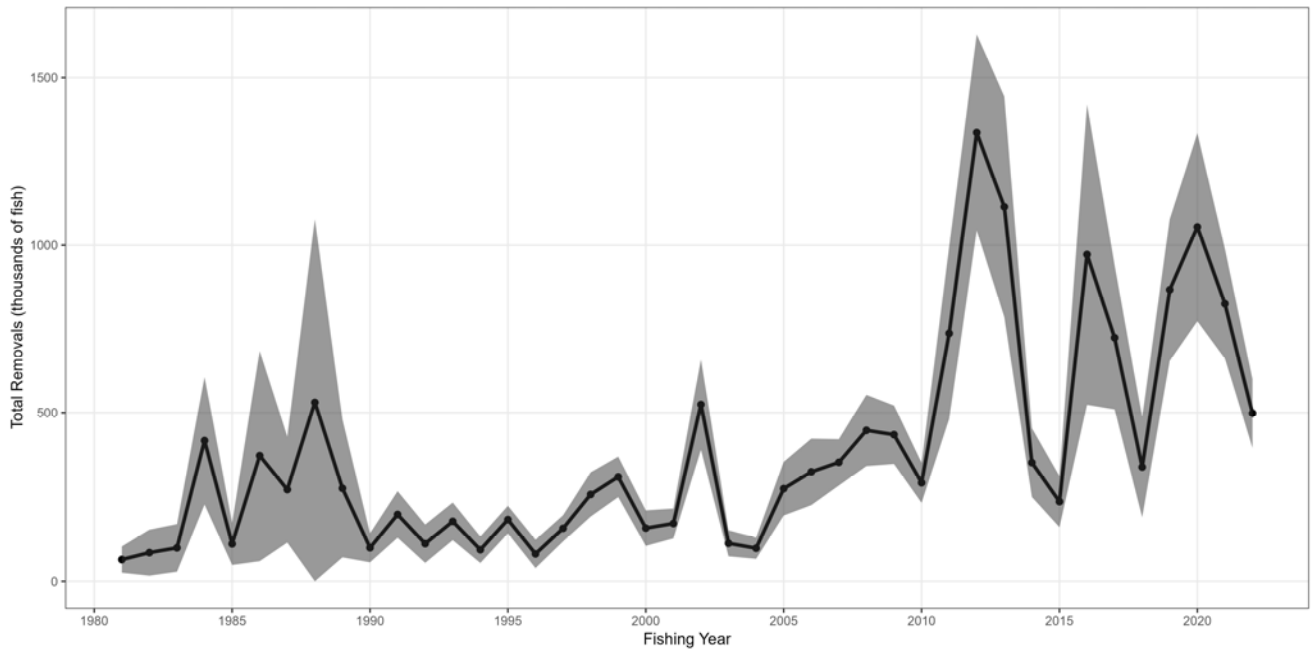
Figure 33. MRIP recreational catch estimates of red drum from the southern stock. Dead discards are calculated with an assumed 8% discard mortality of releases. \*\*2022 data are preliminary.



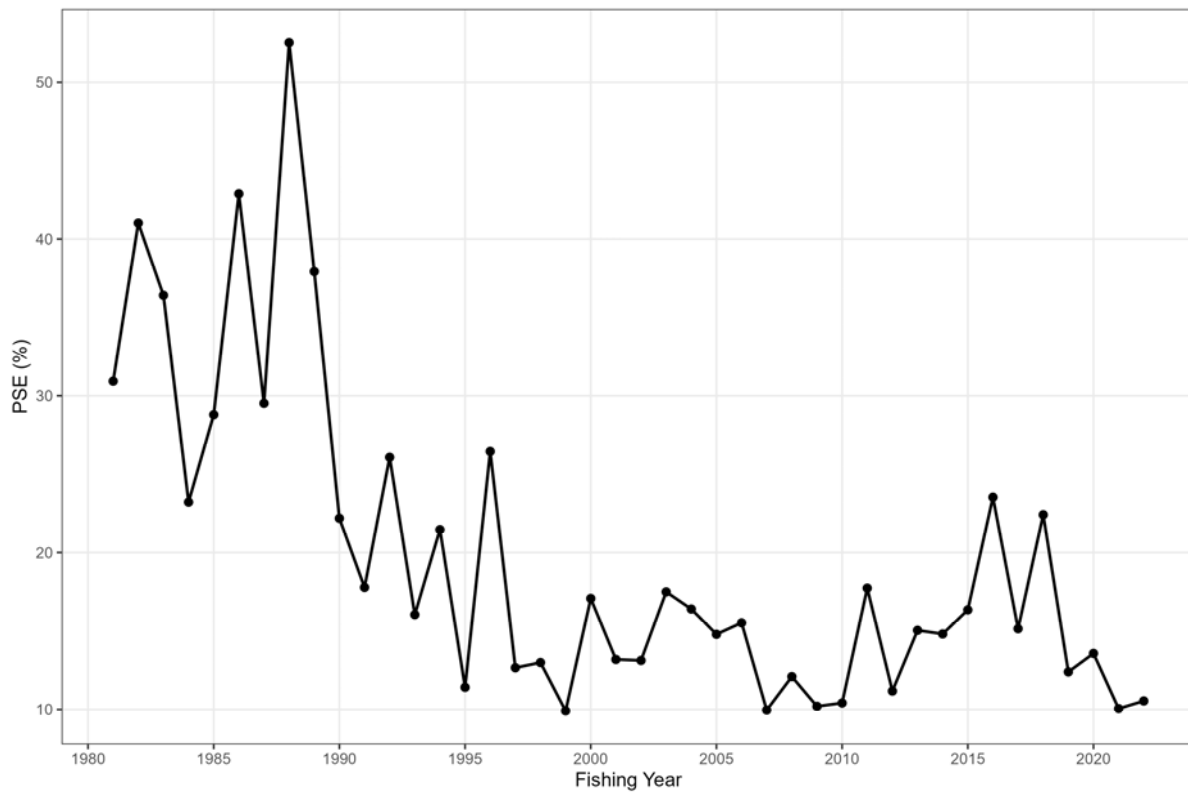
**Figure 34. Proportional standard error of MRIP recreational catch estimates of red drum from the southern stock. \*\*2022 data are preliminary.**



**Figure 35. MRIP recreational catch estimates of red drum from southern stock states with 95% confidence intervals (shaded regions). Dead discards are calculated with an assumed 8% discard mortality of releases and confidence intervals are calculated assuming the same PSEs as for released alive estimates. \*\*2022 data are preliminary.**

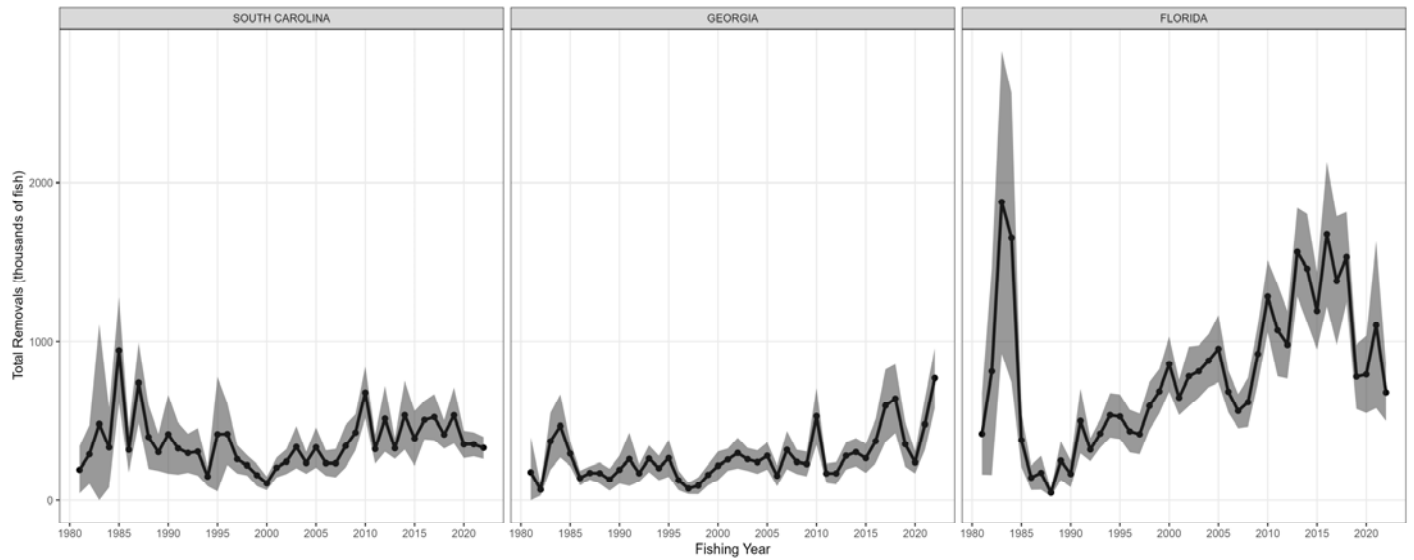


**Figure 36. MRIP recreational total removal estimates of red drum from the northern stock with 95% confidence intervals (shaded regions). Dead discards are calculated with an assumed 8% discard mortality of releases and confidence intervals are calculated assuming the same PSEs as for released alive estimates. \*\*2022 data are preliminary.**

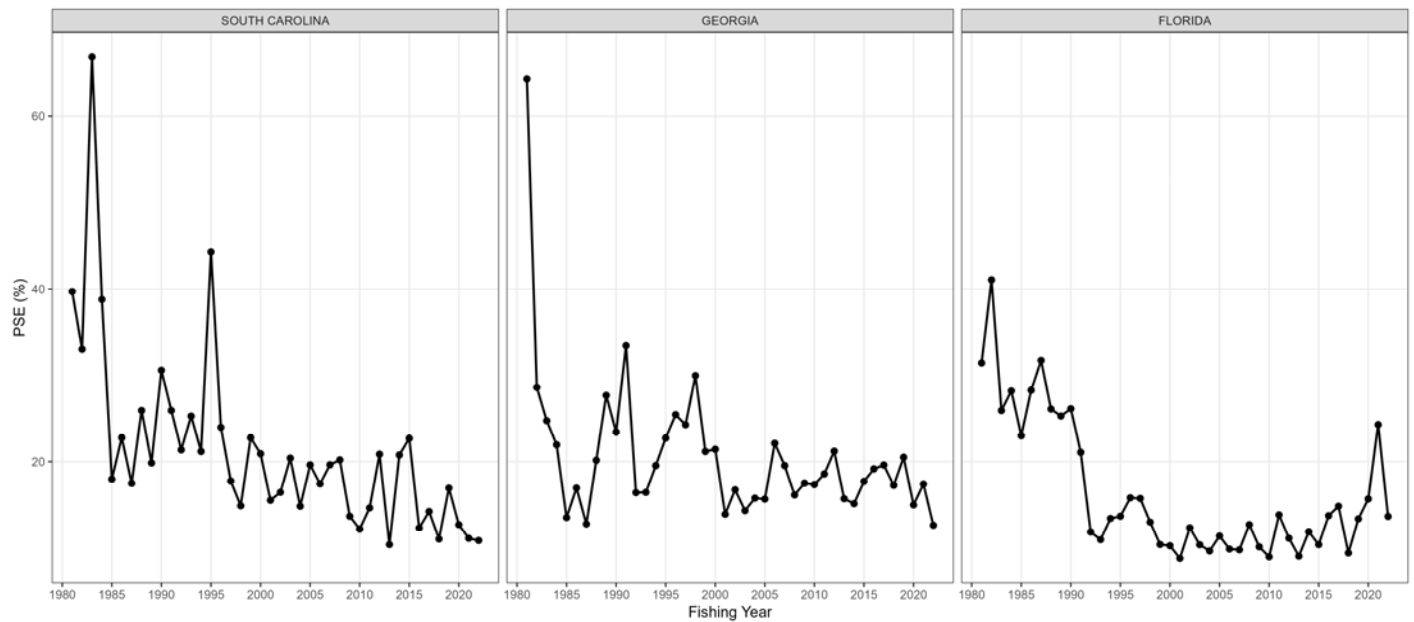


**Figure 37. Proportional standard error of MRIP recreational total removal estimates of red drum from the northern stock (assuming released alive and dead discard PSEs are equal). \*\*2022 data are preliminary.**





**Figure 38. MRIP recreational total removal estimates of red drum from the southern stock with 95% confidence intervals (shaded regions). Dead discards are calculated with an assumed 8% discard mortality of releases and confidence intervals are calculated assuming the same PSEs as for released alive estimates. \*\*2022 data are preliminary.**



**Figure 39. Proportional standard error of MRIP recreational total removal estimates of red drum from the southern stock (assuming released alive and dead discard PSEs are equal). \*\*2022 data are preliminary.**

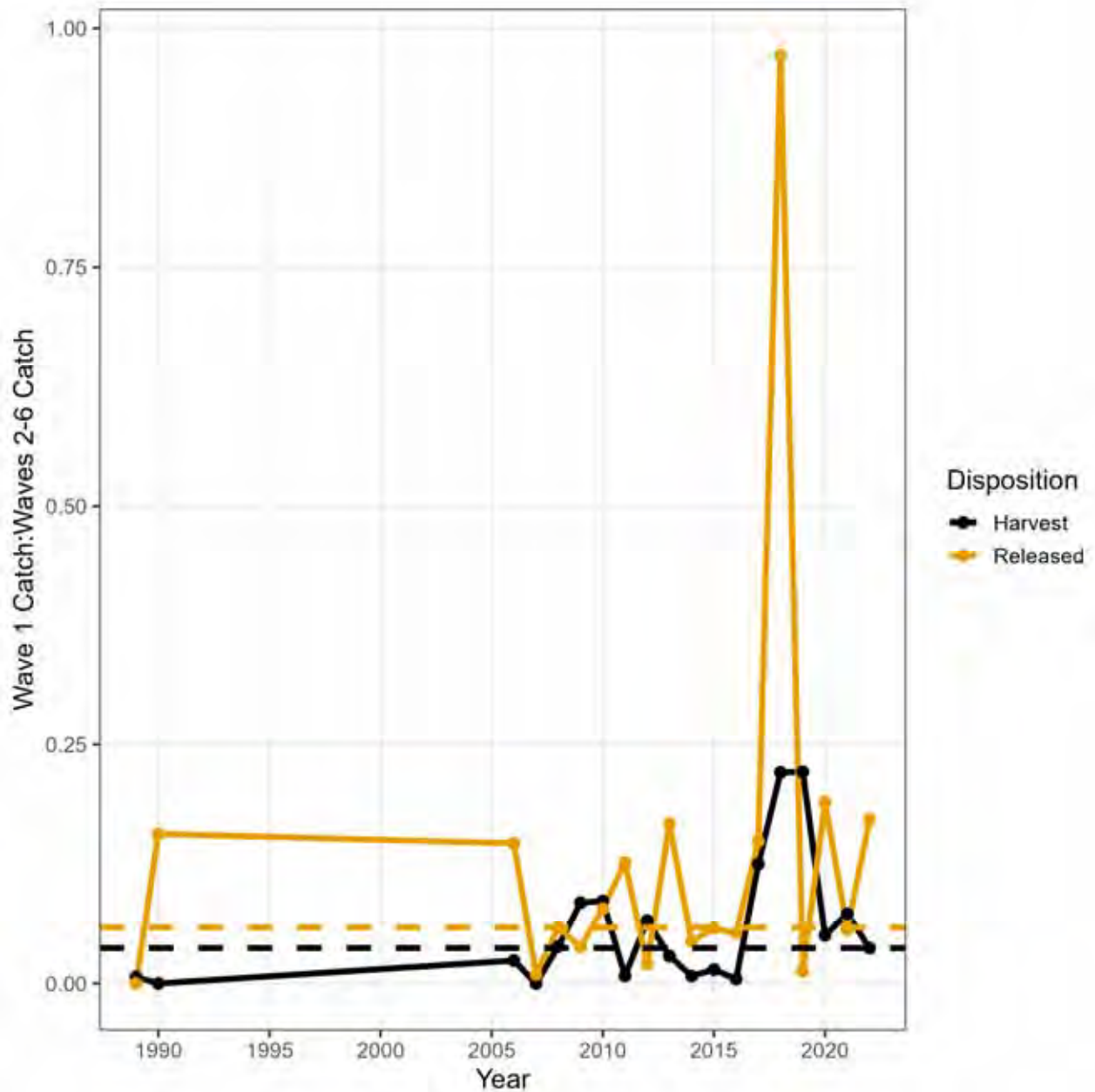


Figure 40. Ratios of wave 1 to waves 2-6 MRIP catch estimates from North Carolina for years when wave 1 catch estimates are available. Dashed horizontal lines show medians of annual ratios.

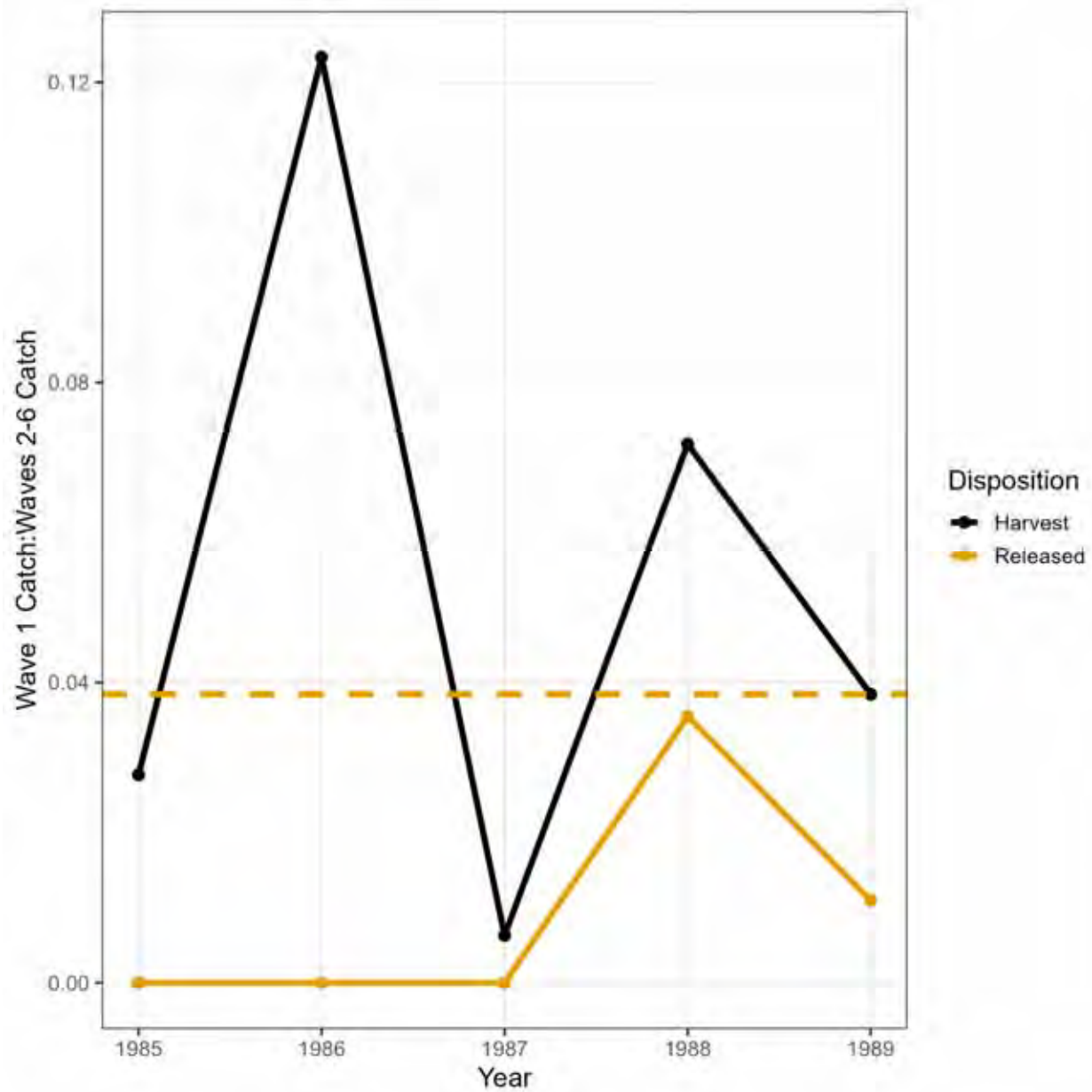


Figure 41. Ratios of wave 1 to waves 2-6 MRIP catch estimates from Georgia for years when wave 1 catch estimates are available. Dashed horizontal lines show medians of annual ratios. Due to a median of zero for released alive estimates, the harvest ratio ( $\approx 0.04$ ) was used for the released alive estimates and overlaps in this figure.

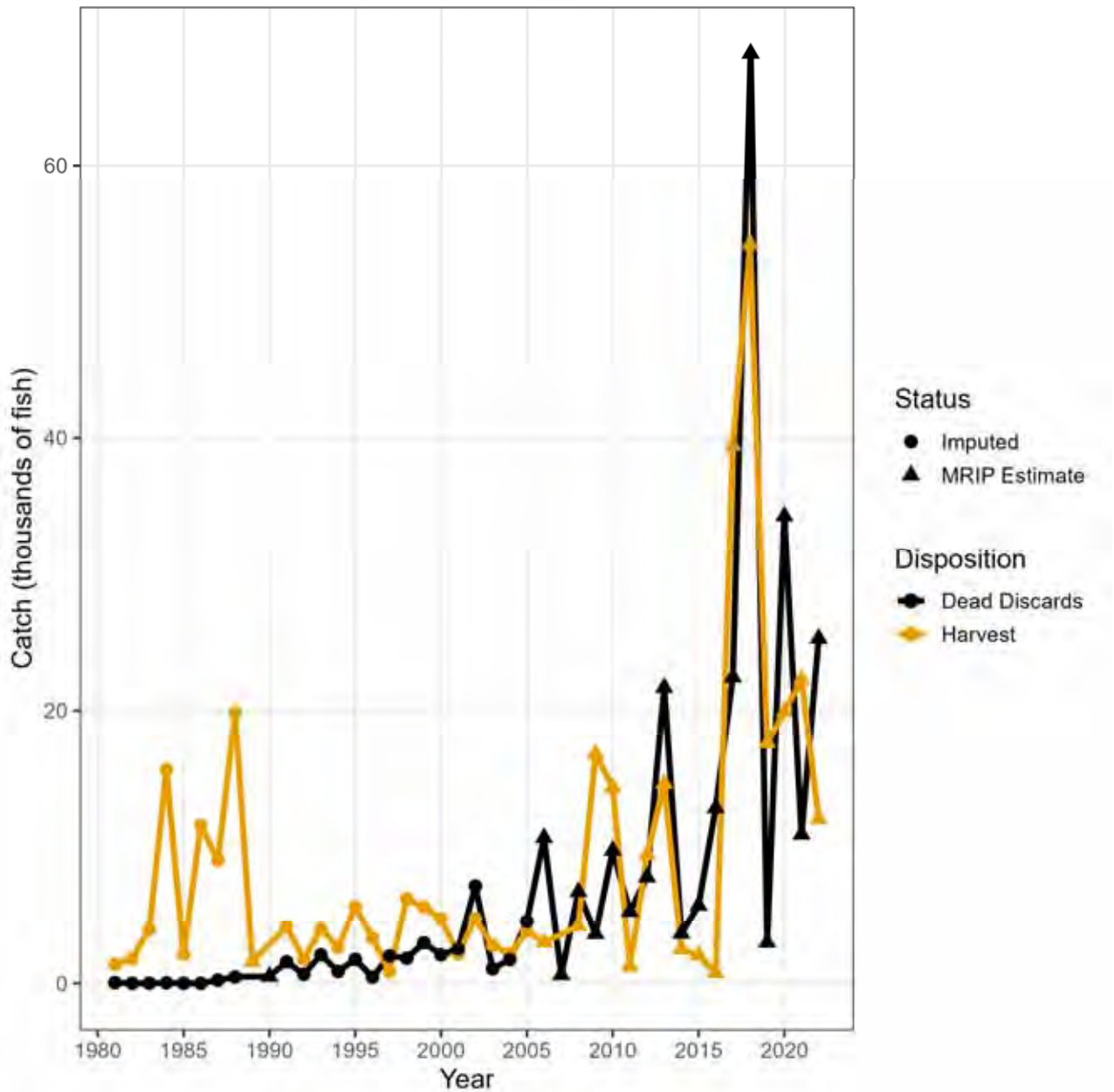


Figure 42. Wave 1 recreational catch estimates of red drum from North Carolina provided by MRIP and imputed with ratios of wave 1 to waves 2-6 MRIP catch estimates.

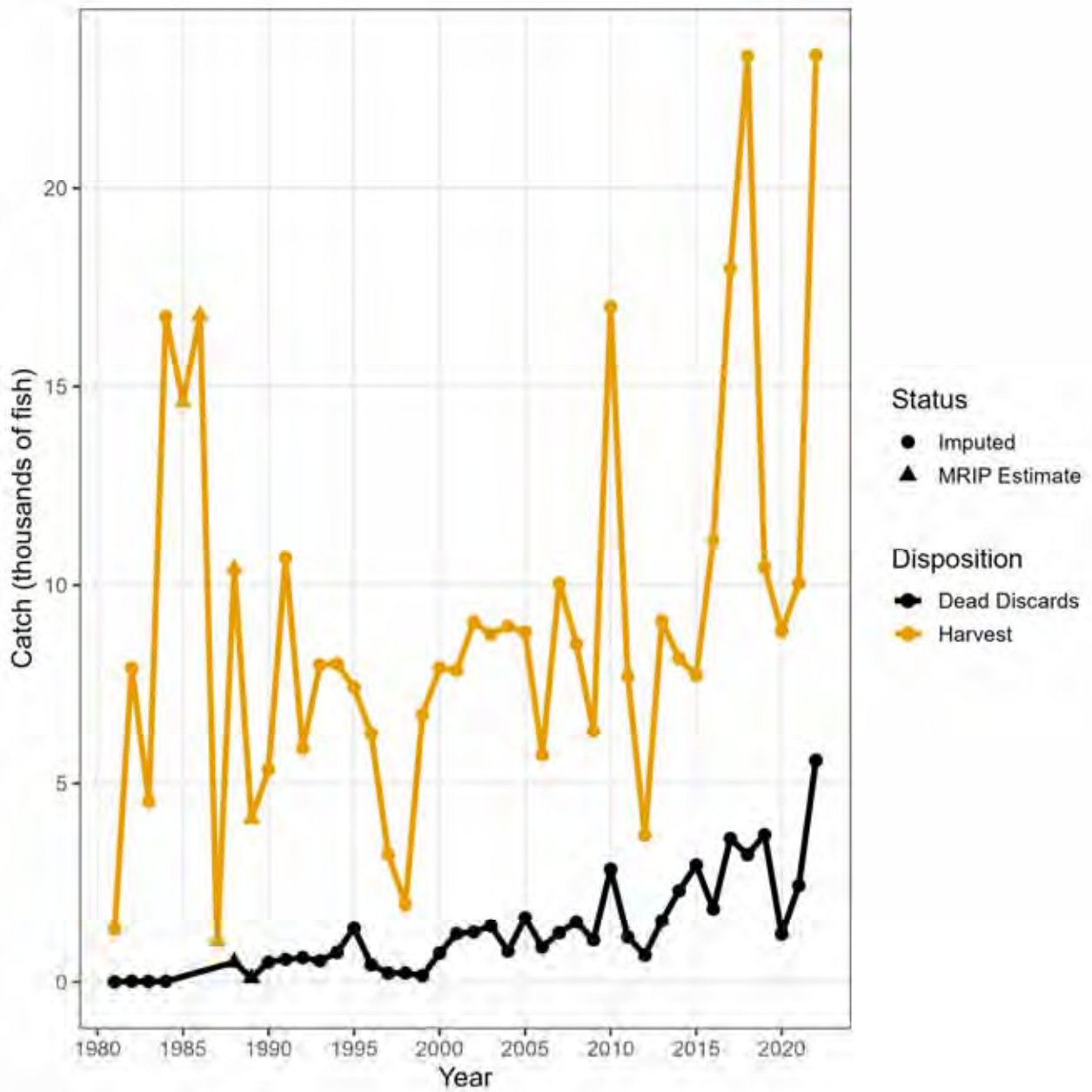


Figure 43. Wave 1 recreational catch estimates of red drum from Georgia provided by MRIP and imputed with ratios of wave 1 to waves 2-6 MRIP catch estimates.

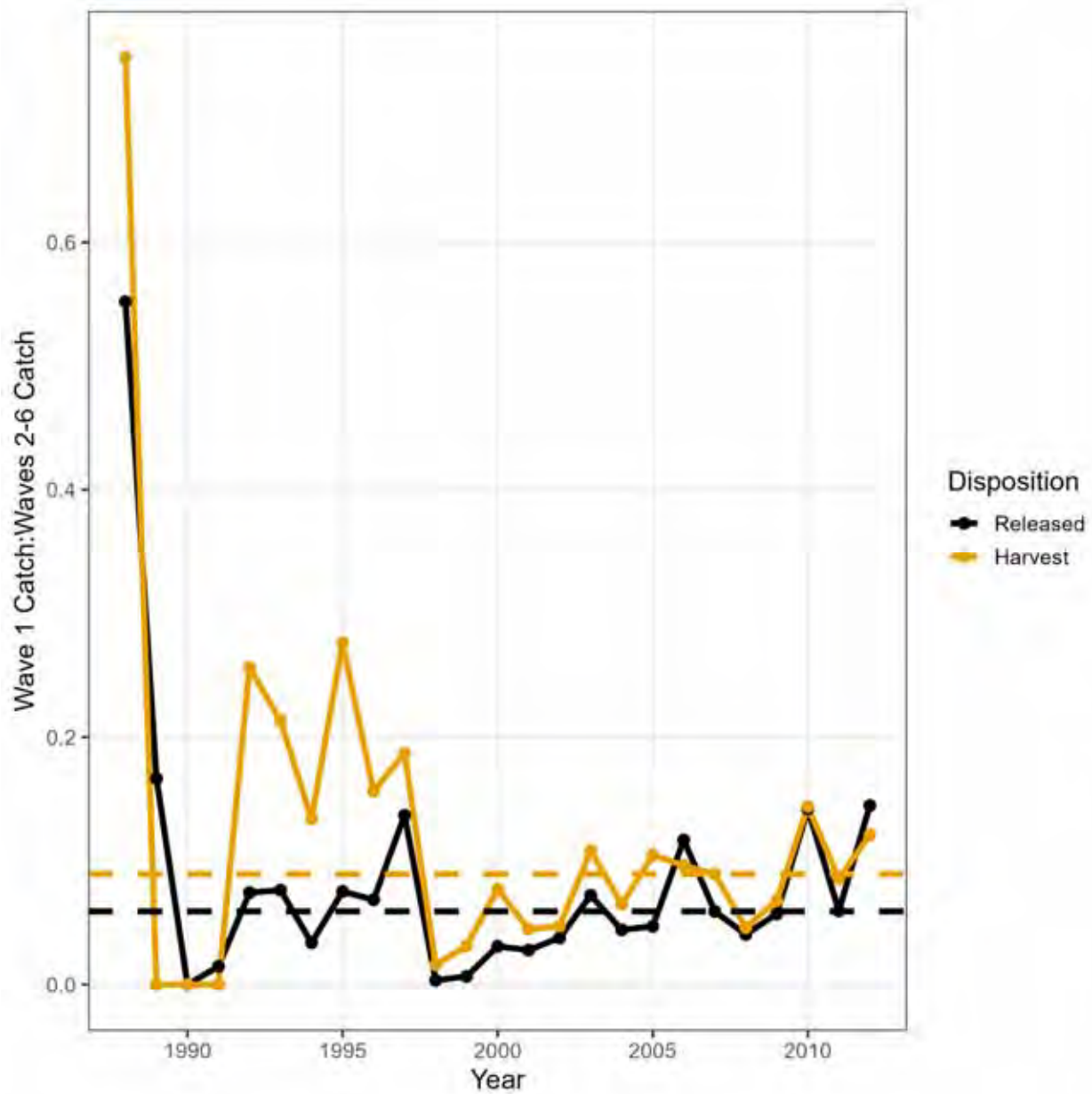


Figure 44. Ratios of wave 1 to waves 2-6 State Finfish Survey catch frequencies from South Carolina. Dashed horizontal lines show medians of annual ratios.

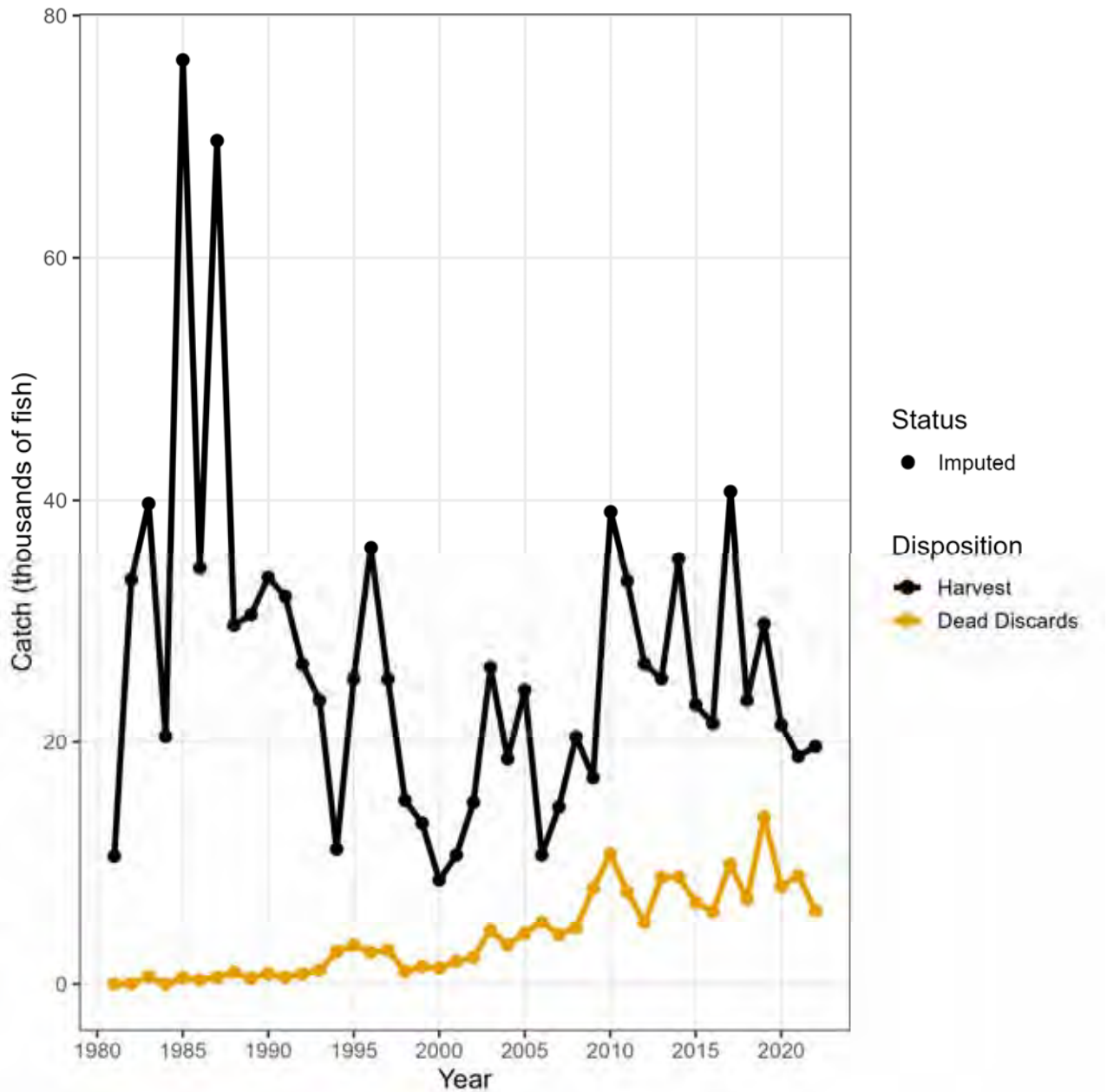


Figure 45. Wave 1 recreational catch estimates of red drum from South Carolina provided by MRIP and imputed with ratios of wave 1 to waves 2-6 State Finfish Survey catch frequencies.

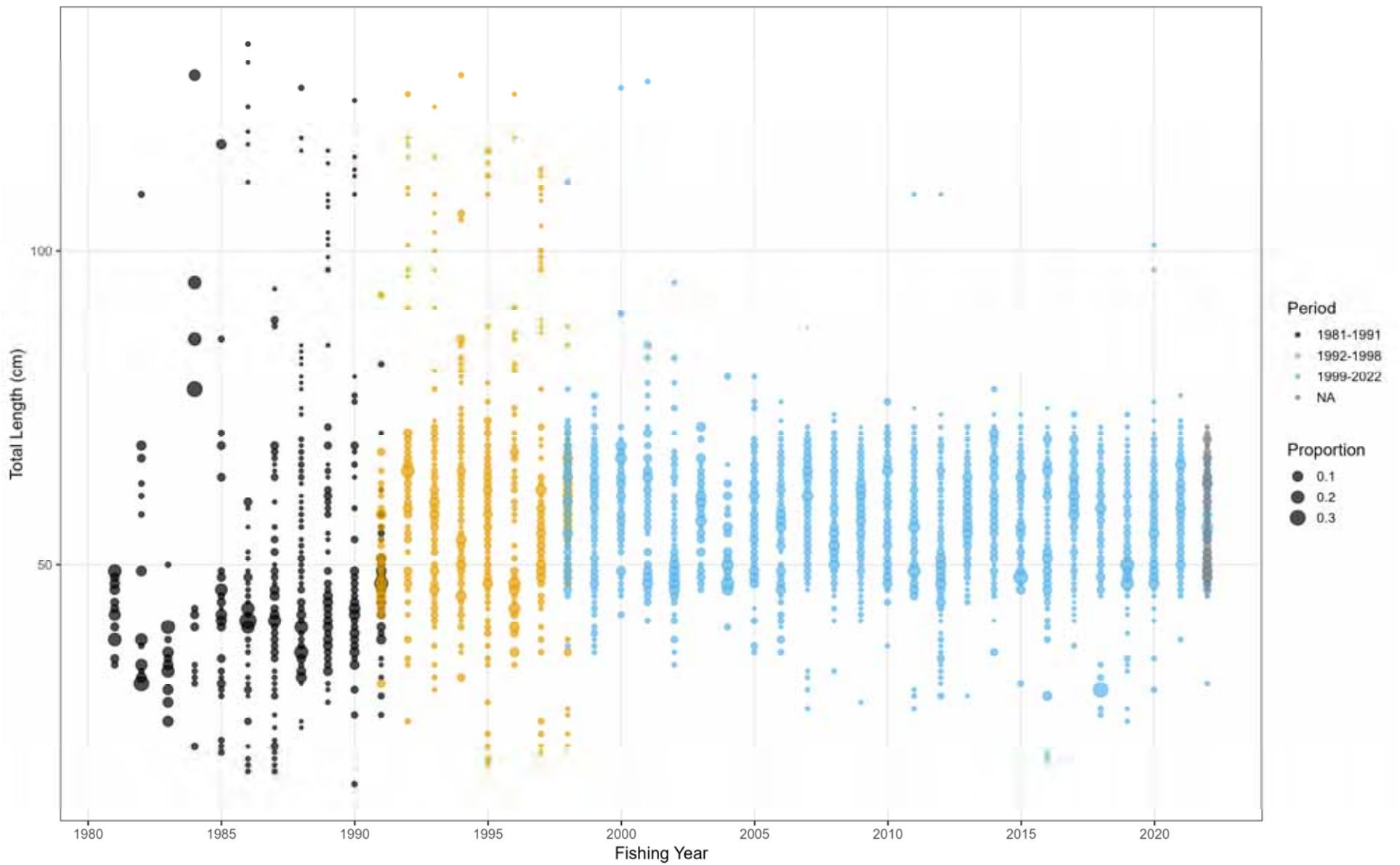
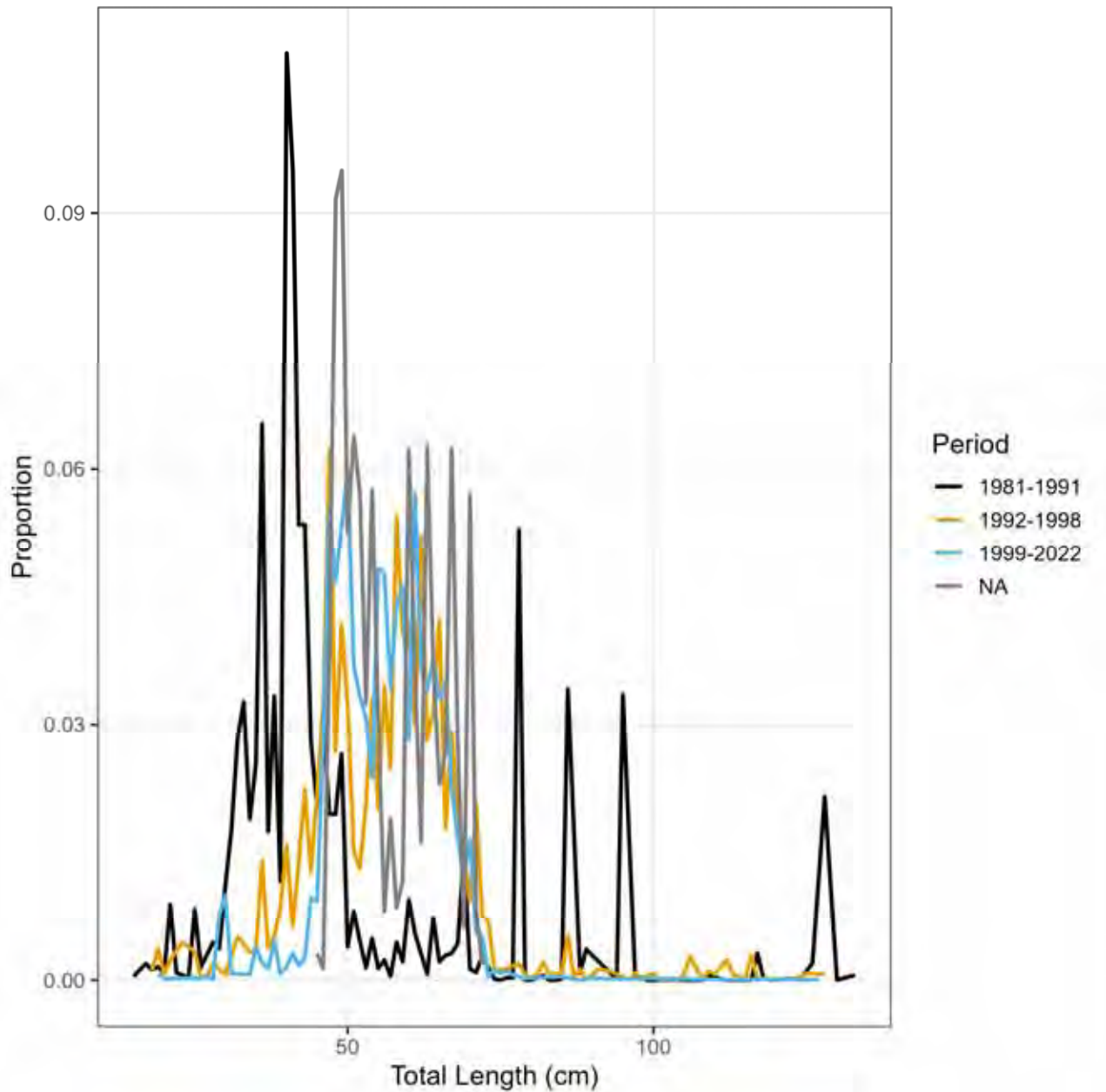
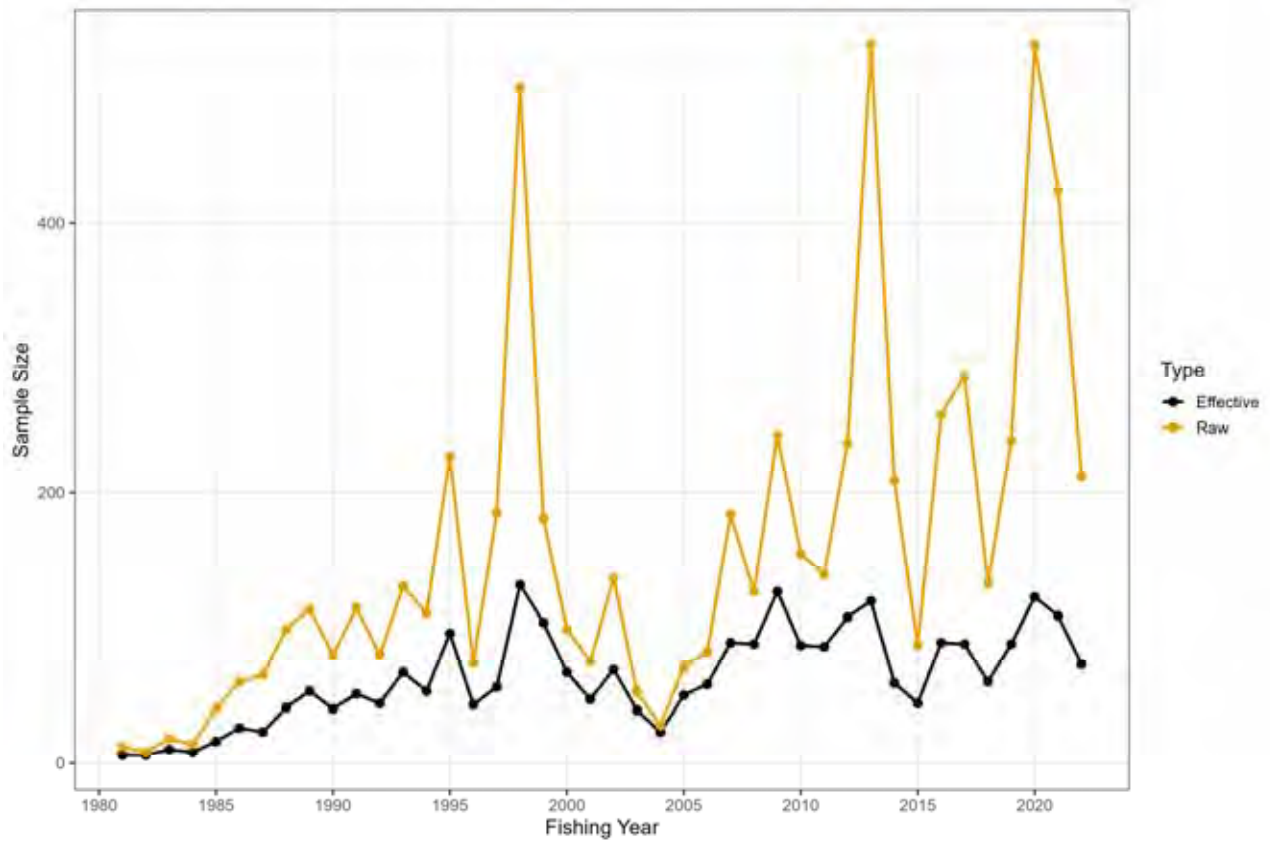


Figure 46. MRIP size composition estimates of recreational red drum harvest from the northern stock. \*\*2022 data are preliminary.





**Figure 47. MRIP size composition estimates of recreational red drum harvest from the northern stock aggregated by regulation periods. \*\*2022 data are preliminary.**



**Figure 48. Number of MRIP primary sampling units that encountered red drum in the northern stock for length measurements (effective) and number of individual red drum measured for length (raw). \*\*2022 data are preliminary.**

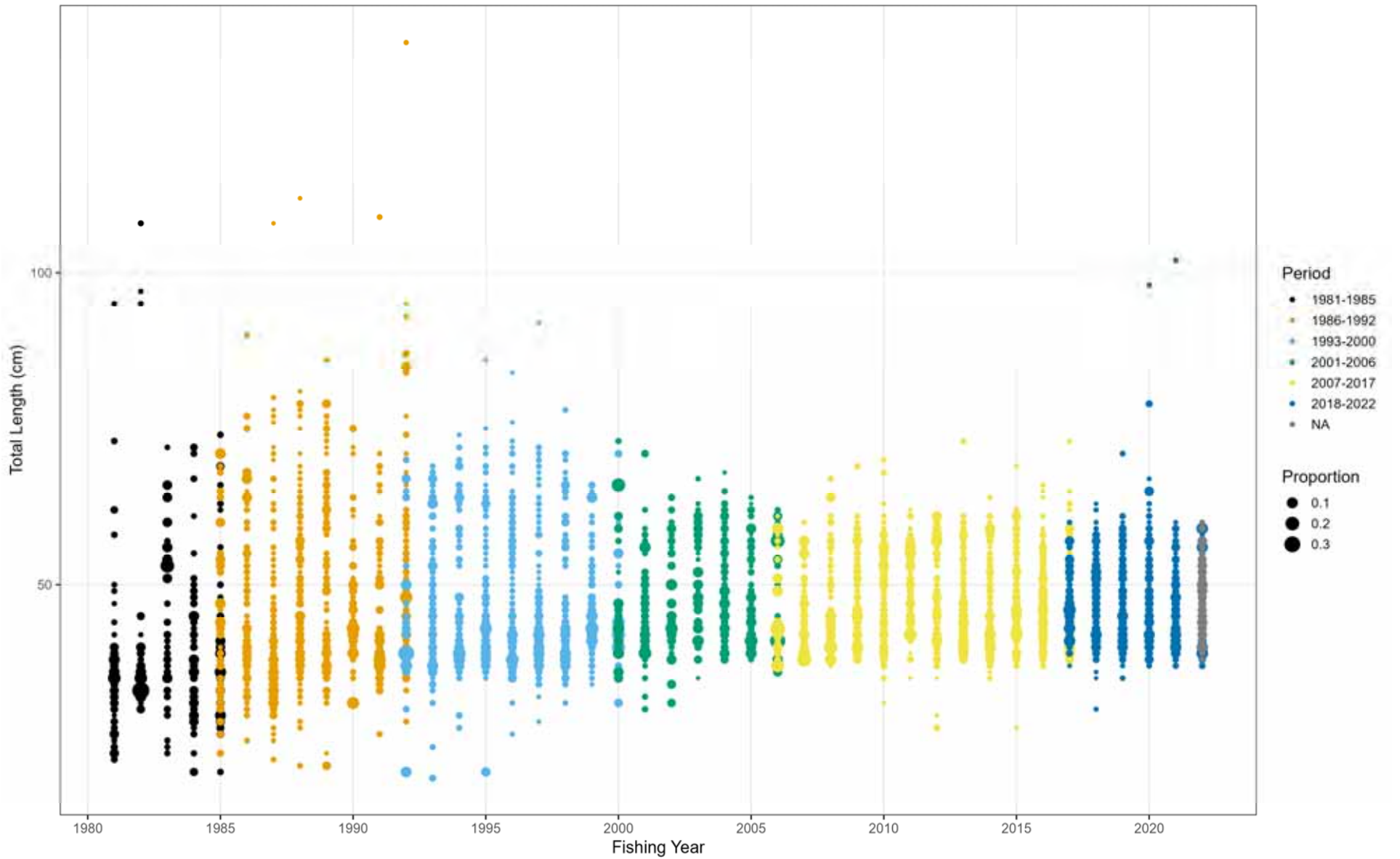


Figure 49. MRIP size composition estimates of recreational red drum harvest from South Carolina in the southern stock. \*\*2022 data are preliminary.

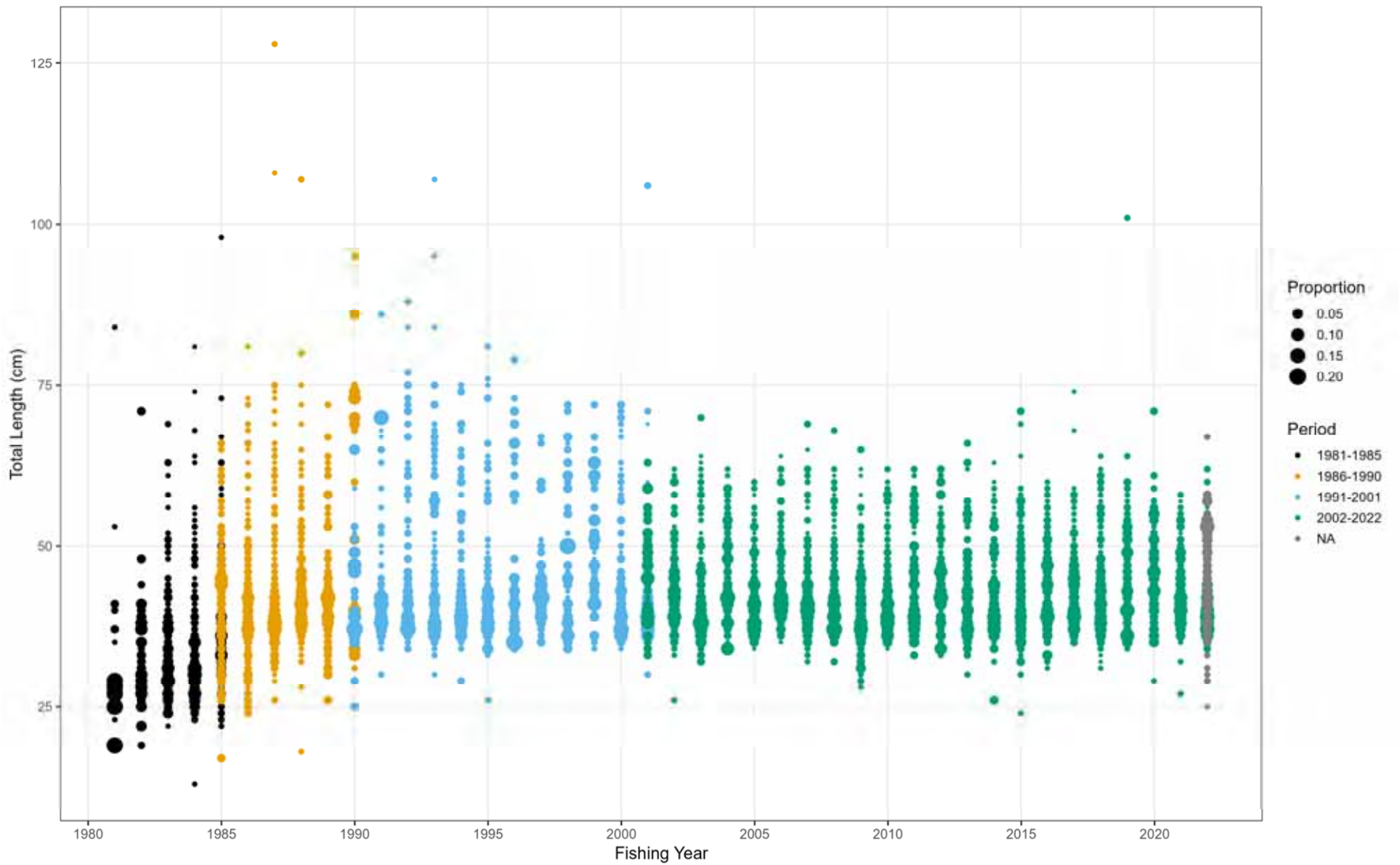


Figure 50. MRIP size composition estimates of recreational red drum harvest from Georgia in the southern stock. \*\*2022 data are preliminary.

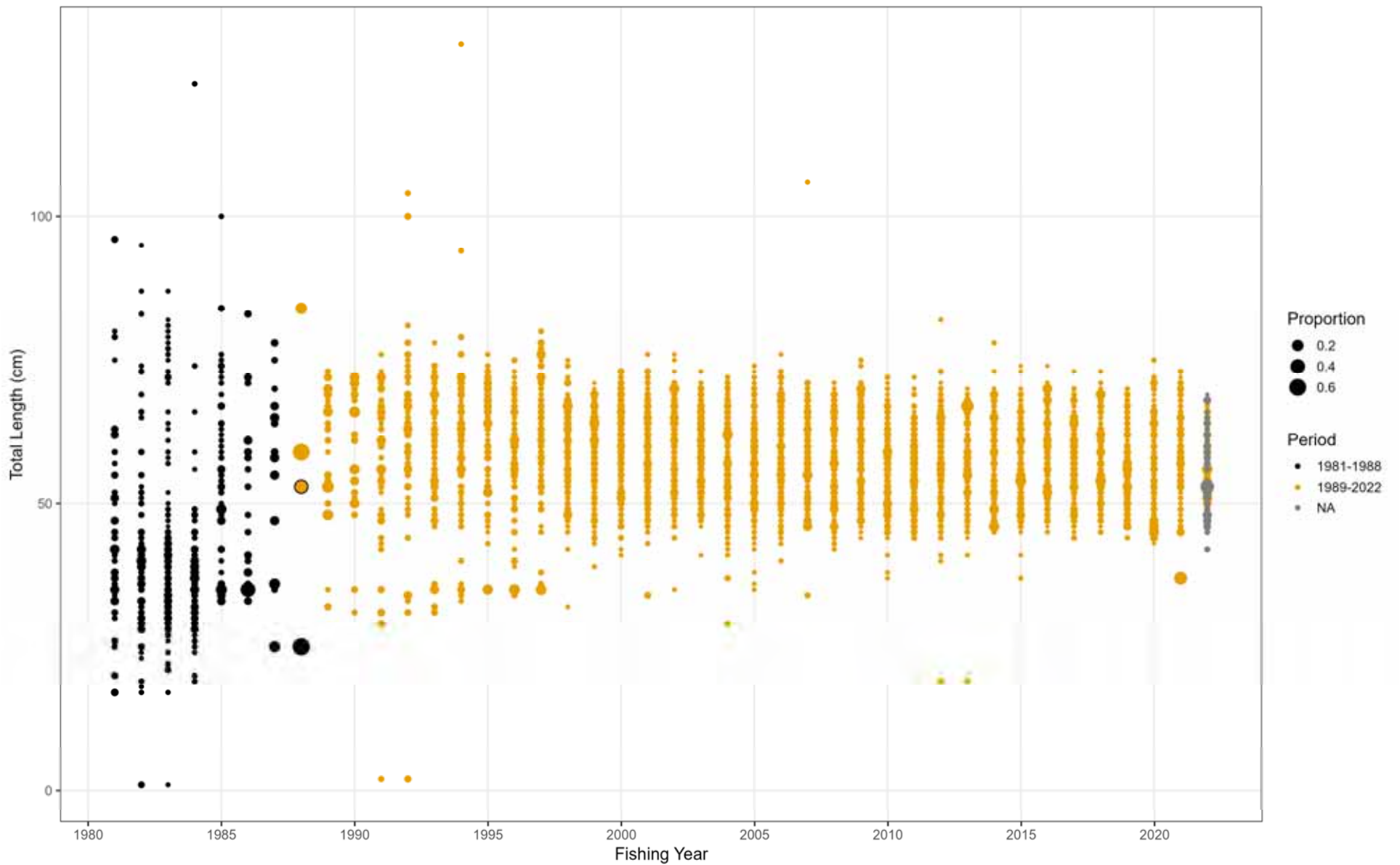
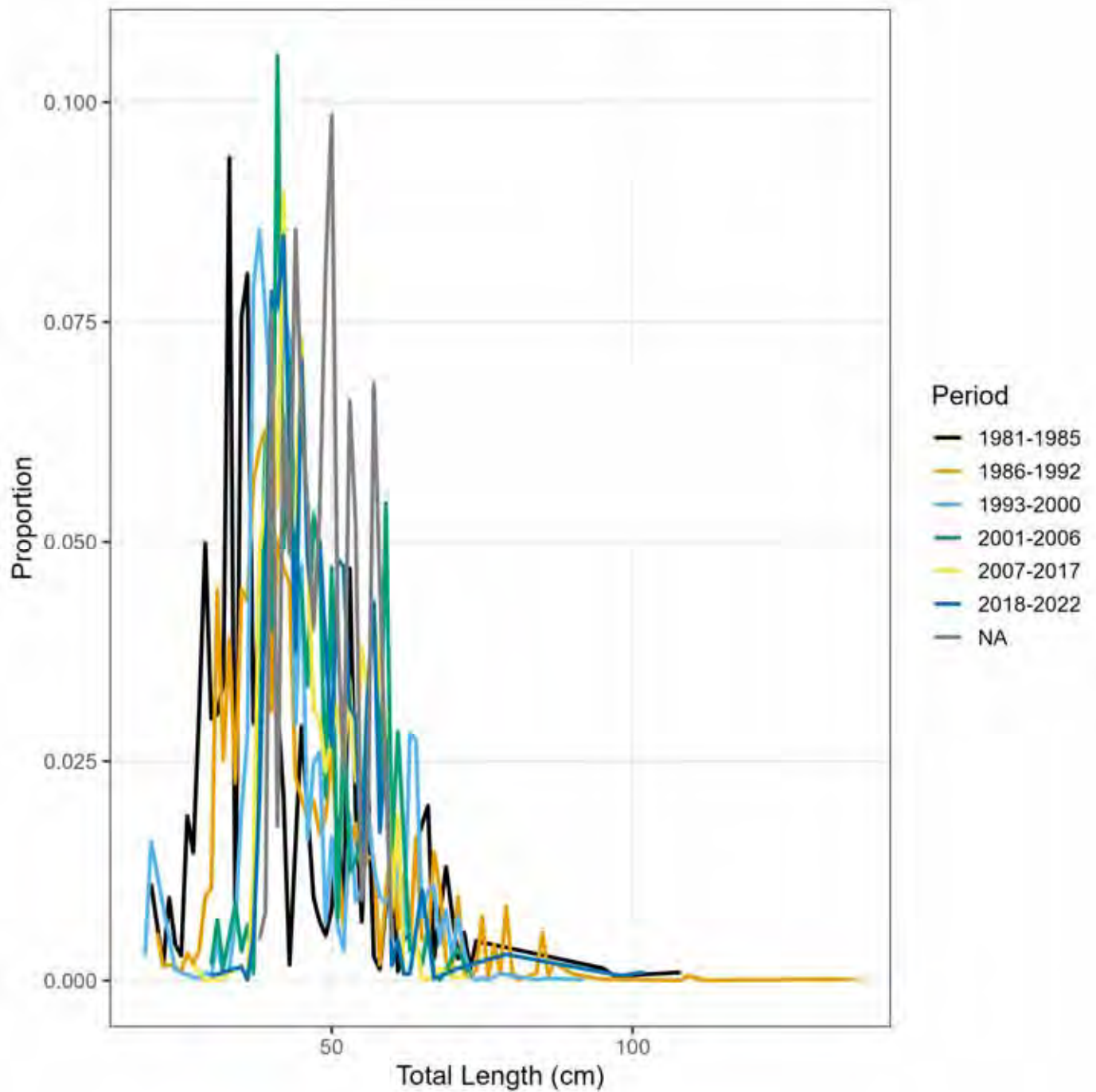
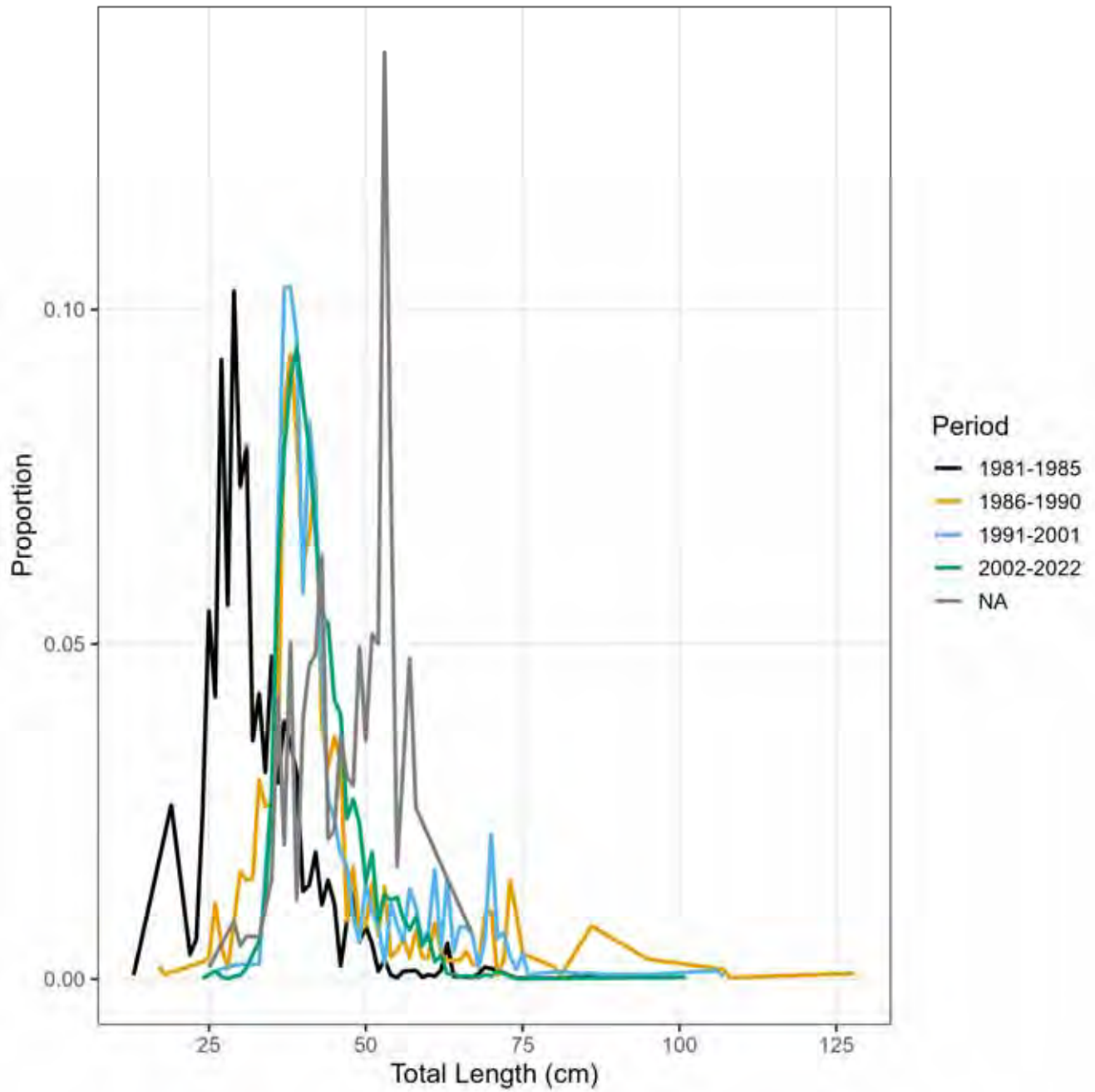


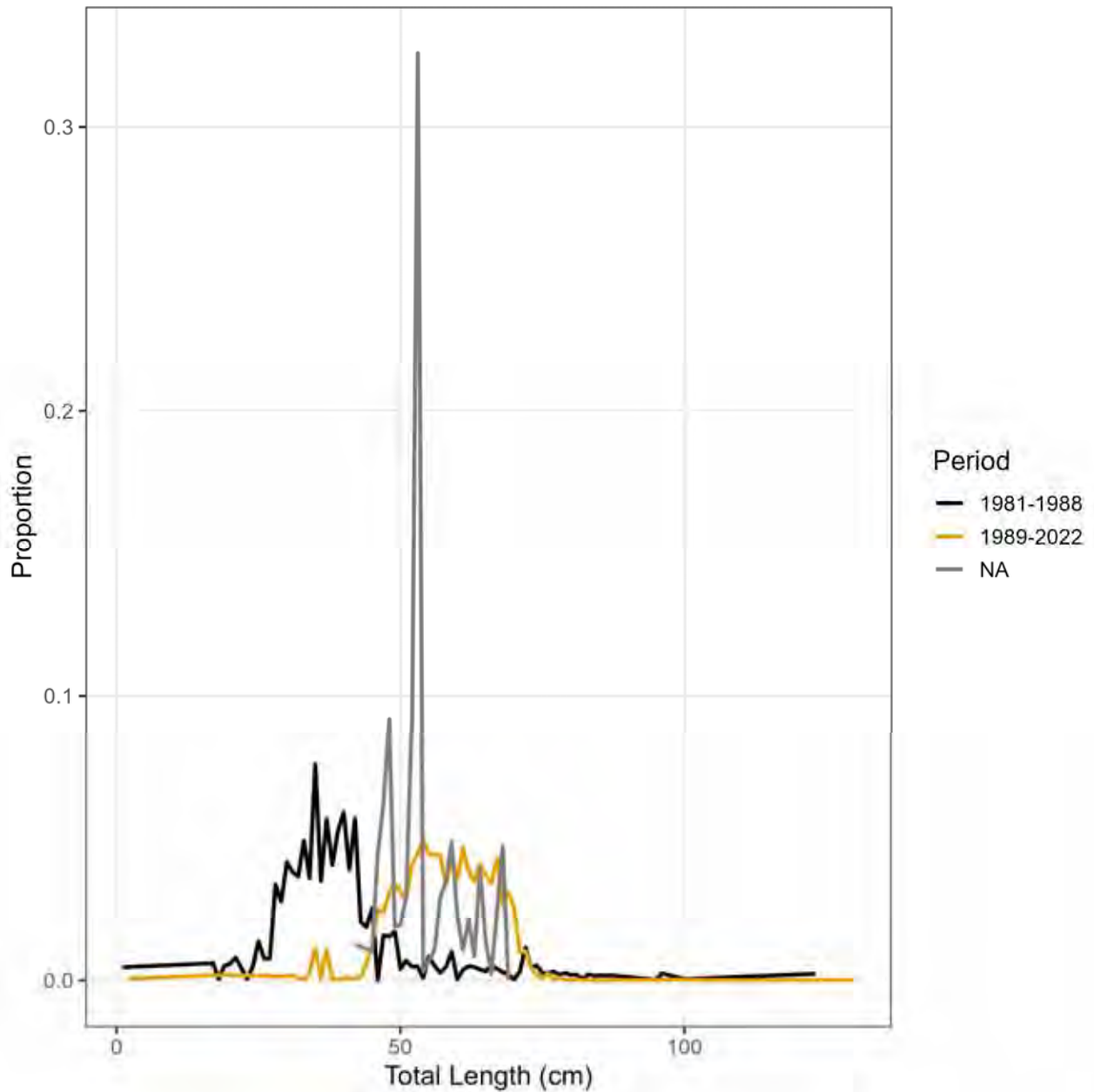
Figure 51. MRIP size composition estimates of recreational red drum harvest from Florida in the southern stock. \*\*2022 data are preliminary.



**Figure 52. MRIP size composition estimates of recreational red drum harvest from South Carolina aggregated by regulation periods. \*\*2022 data are preliminary.**

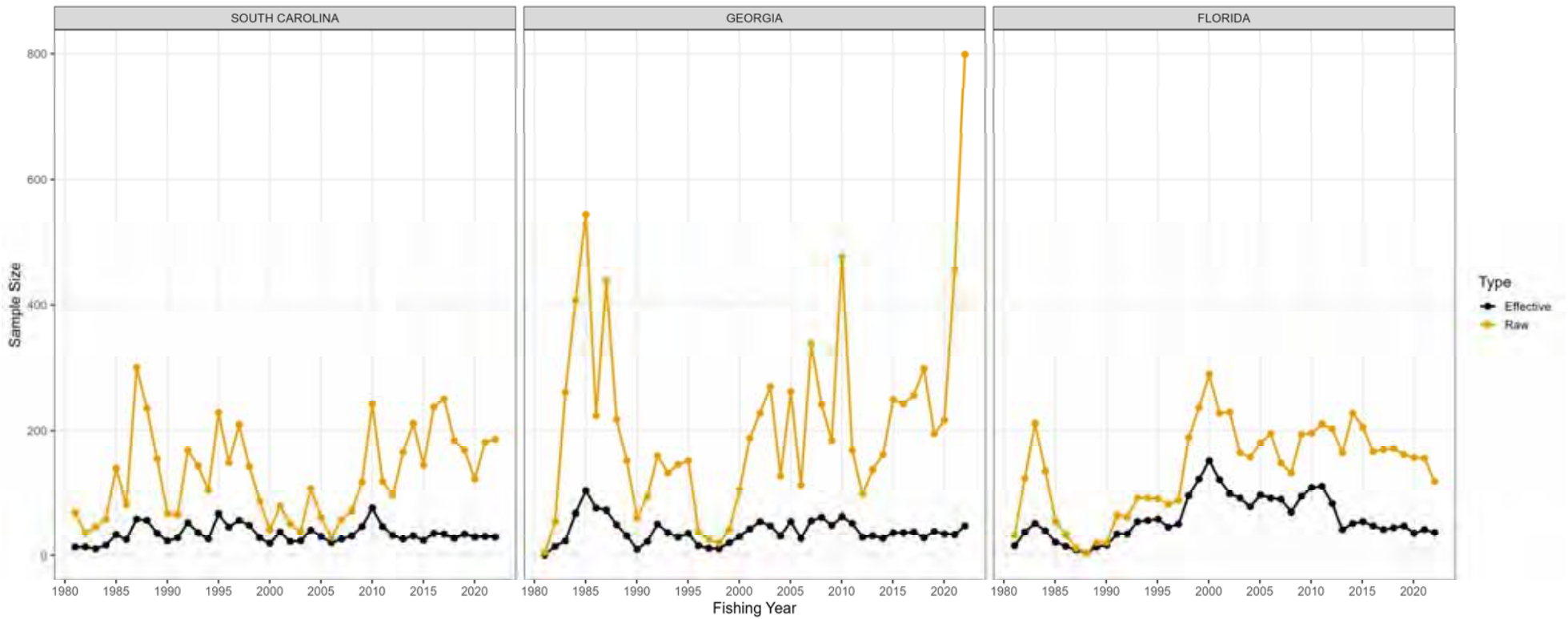


**Figure 53. MRIP size composition estimates of recreational red drum harvest from Georgia aggregated by regulation periods. \*\*2022 data are preliminary.**

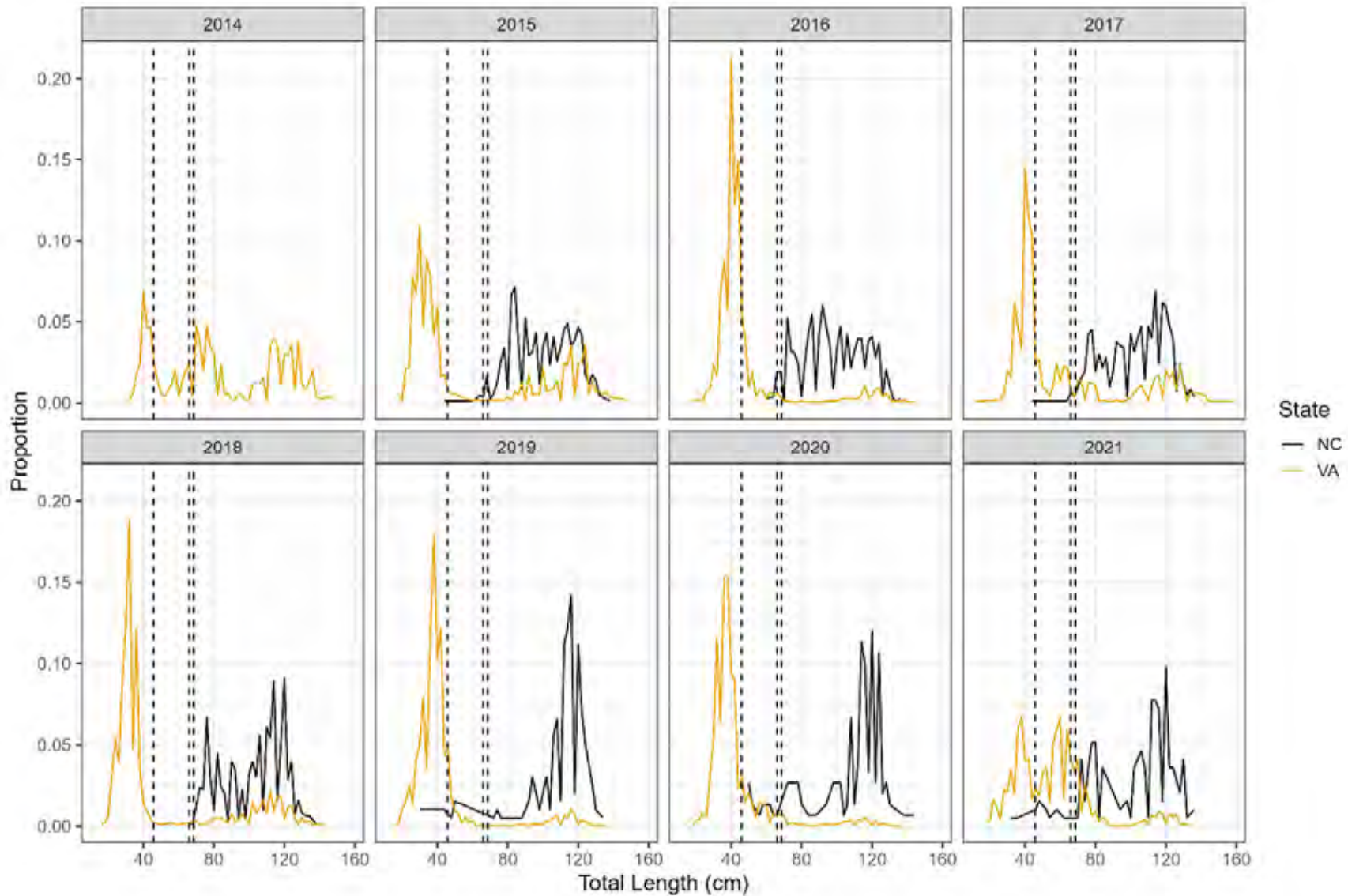


**Figure 54. MRIP size composition estimates of recreational red drum harvest from Florida aggregated by regulation periods. \*\*2022 data are preliminary.**

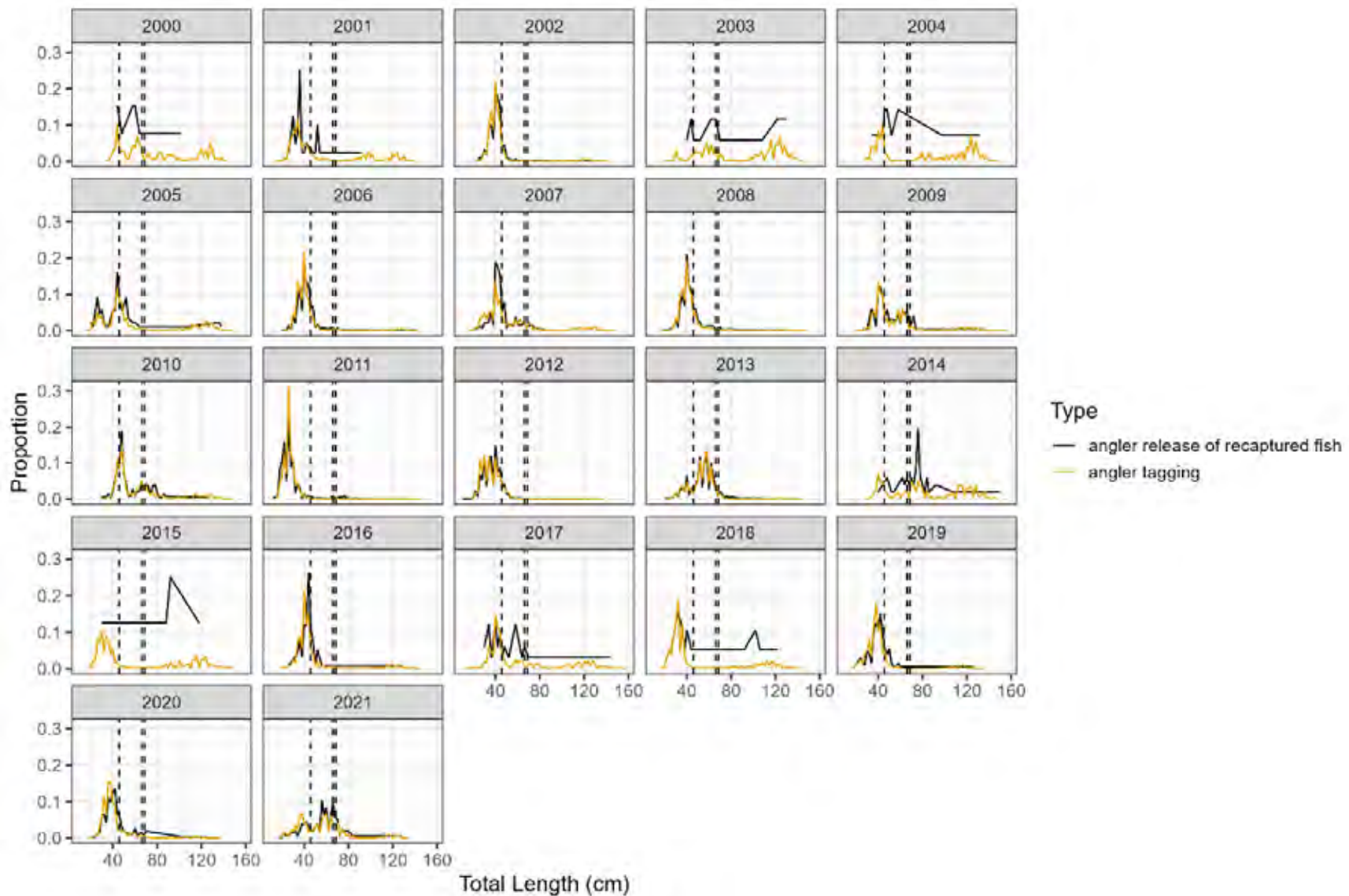




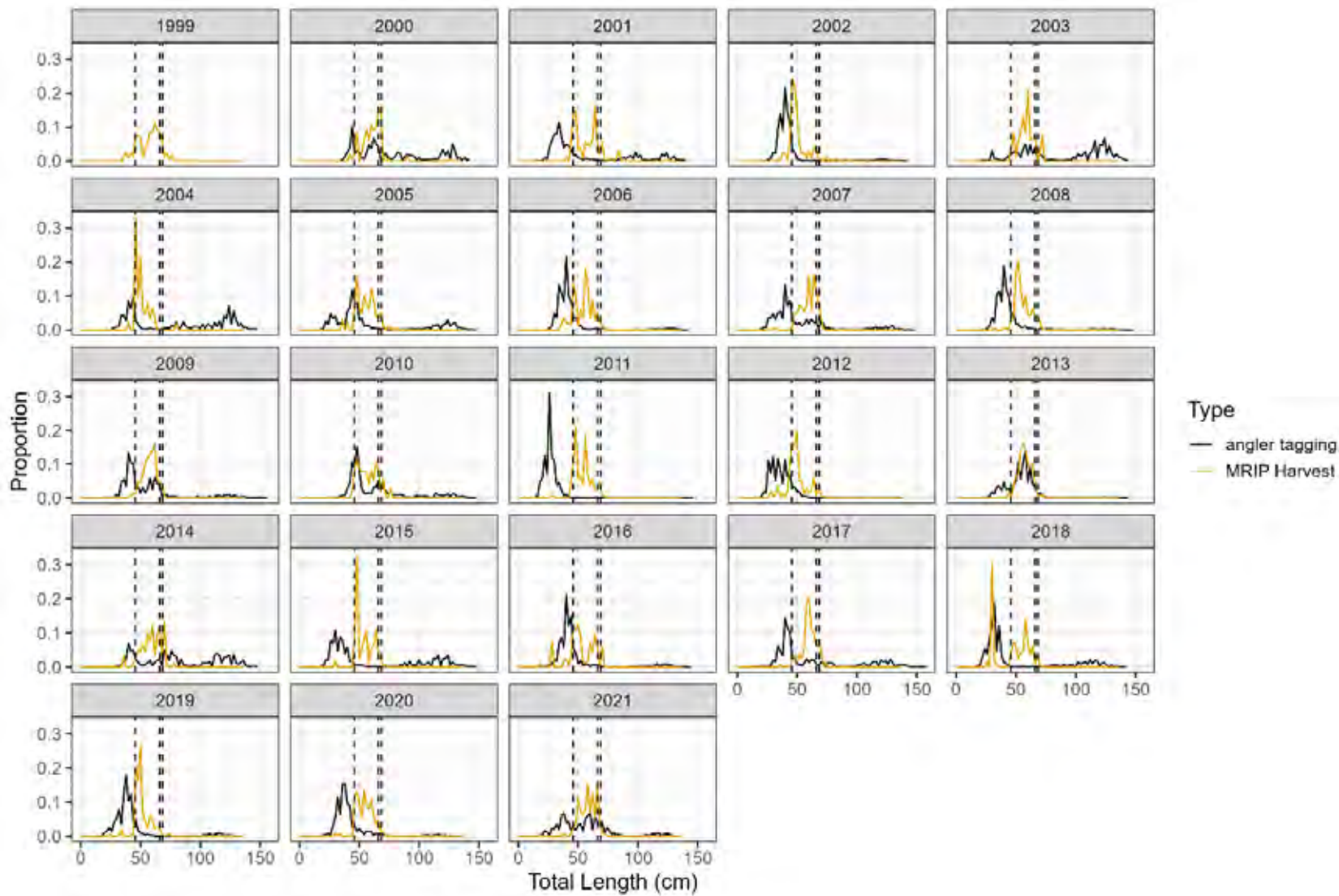
**Figure 55. Number of MRIP primary sampling units that encountered red drum in the southern stock for length measurements (effective) and number of individual red drum measured for length (raw). \*\*2022 data are preliminary.**



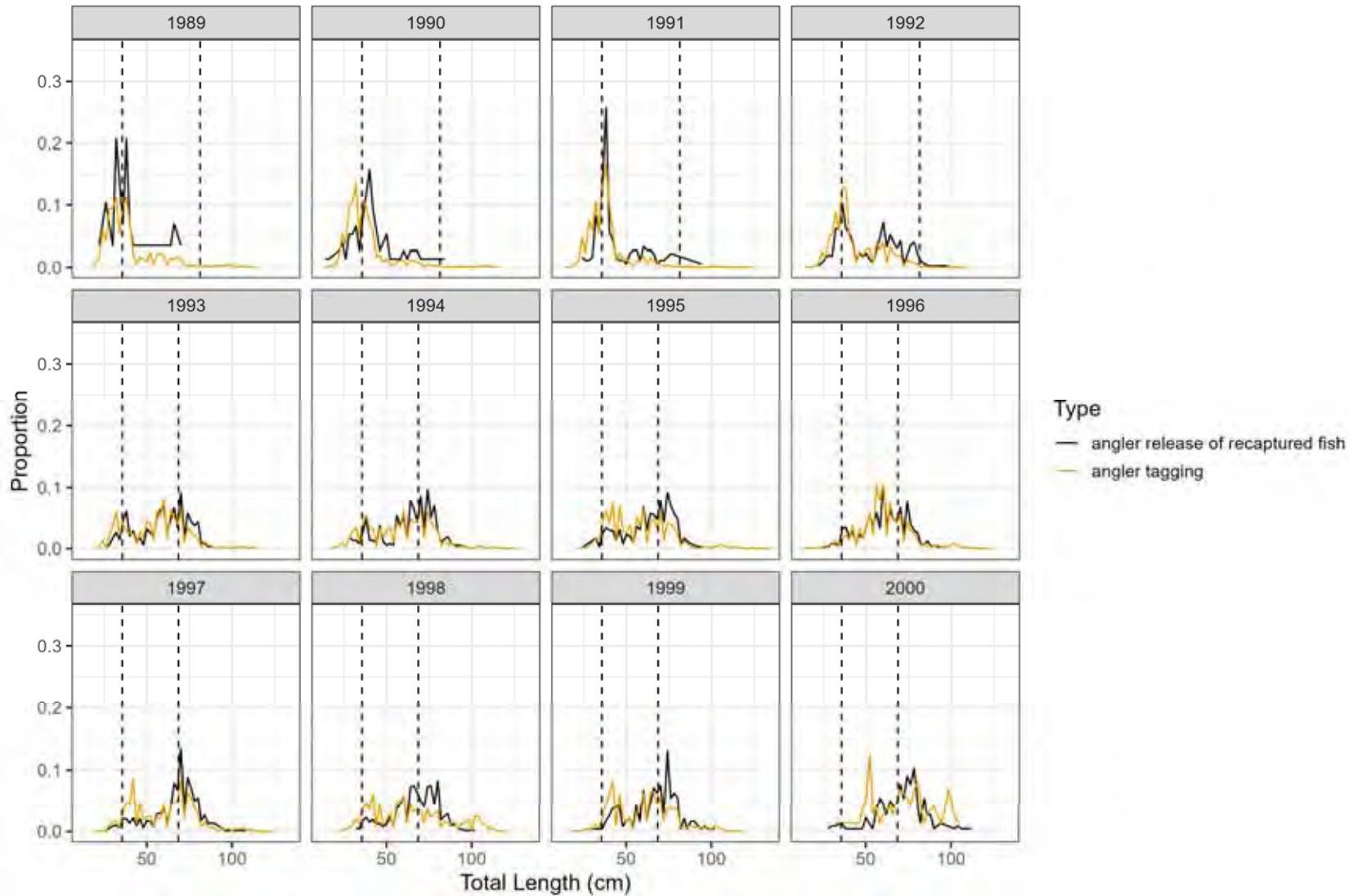
**Figure 56. Size distributions of red drum tagged by volunteer anglers participating in the North Carolina Fish Tagging Program and Virginia Game Fish Tagging Program. Horizontal dashed lines indicate slot sizes in place in North Carolina and Virginia in recent years.**



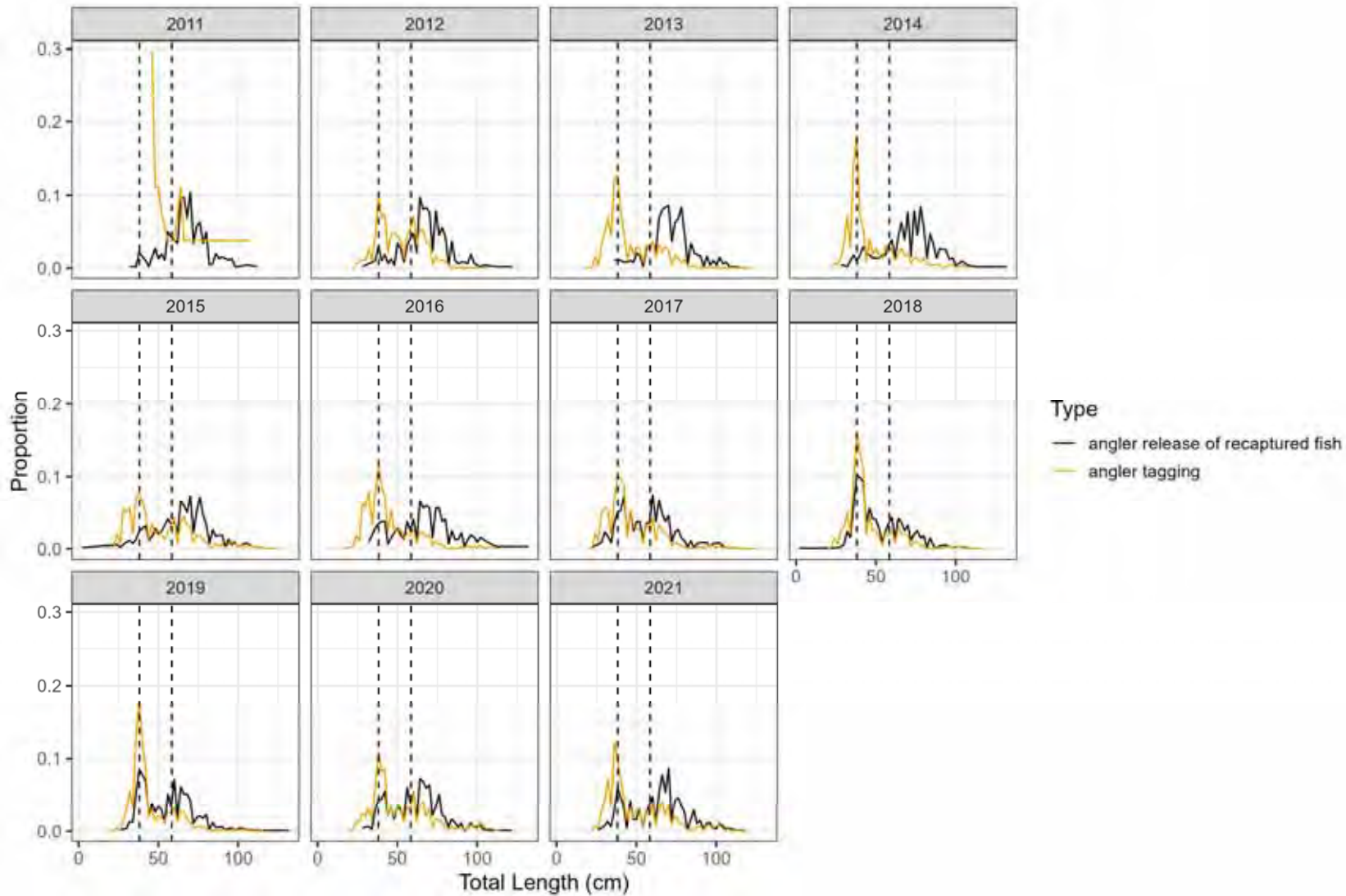
**Figure 57. Size distributions of red drum tagged by volunteer anglers and recaptured and subsequently released by anglers participating in the Virginia Game Fish Tagging Program. Horizontal dashed lines indicate slot sizes in place in North Carolina and Virginia in recent years.**



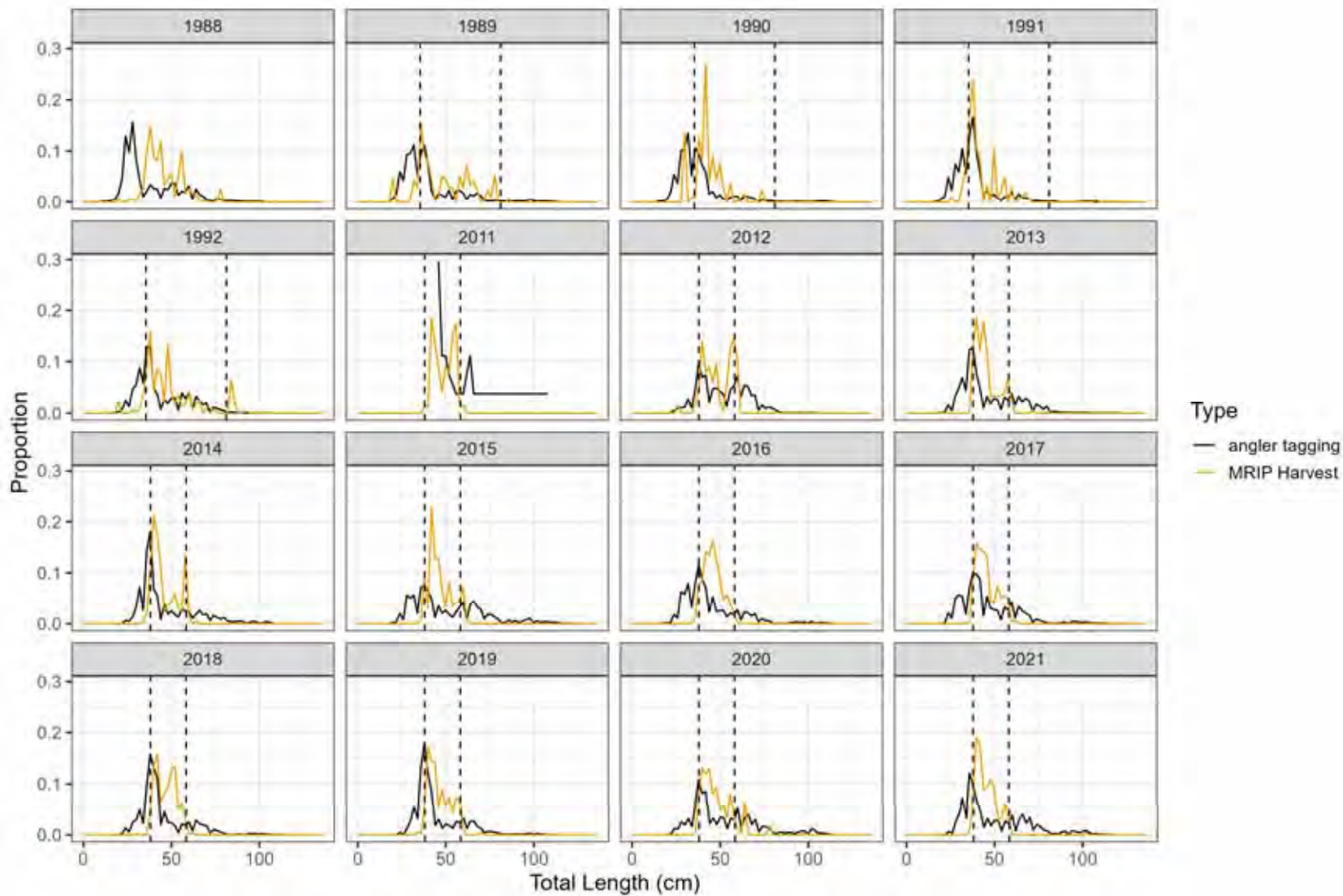
**Figure 58. Size distributions of red drum tagged by volunteer anglers participating in the Virginia Game Fish Tagging Program and of harvested red drum from MRIP estimates for the northern stock. Horizontal dashed lines indicate slot sizes in place in North Carolina and Virginia in recent years.**



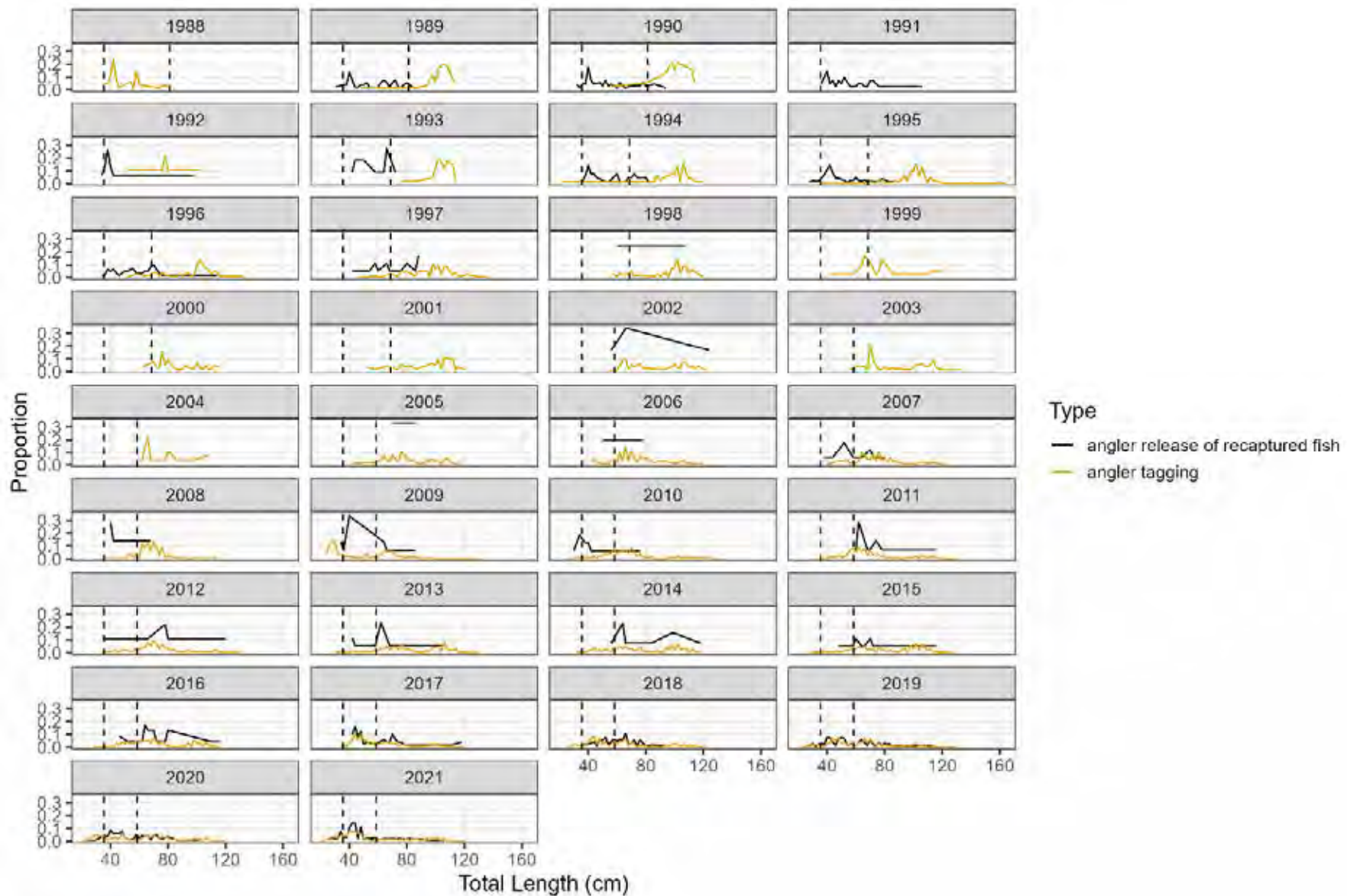
**Figure 59. Size distributions of red drum tagged by volunteer anglers and recaptured and subsequently released by anglers participating in the South Carolina Marine Game Fish Tagging Program from 1989-2000. Horizontal dashed lines indicate slot size in place in South Carolina in recent years.**



**Figure 60. Size distributions of red drum tagged by volunteer anglers and recaptured and subsequently released by anglers participating in the South Carolina Marine Game Fish Tagging Program from 2011-2021. Horizontal dashed lines indicate slot size in place in South Carolina in recent years.**

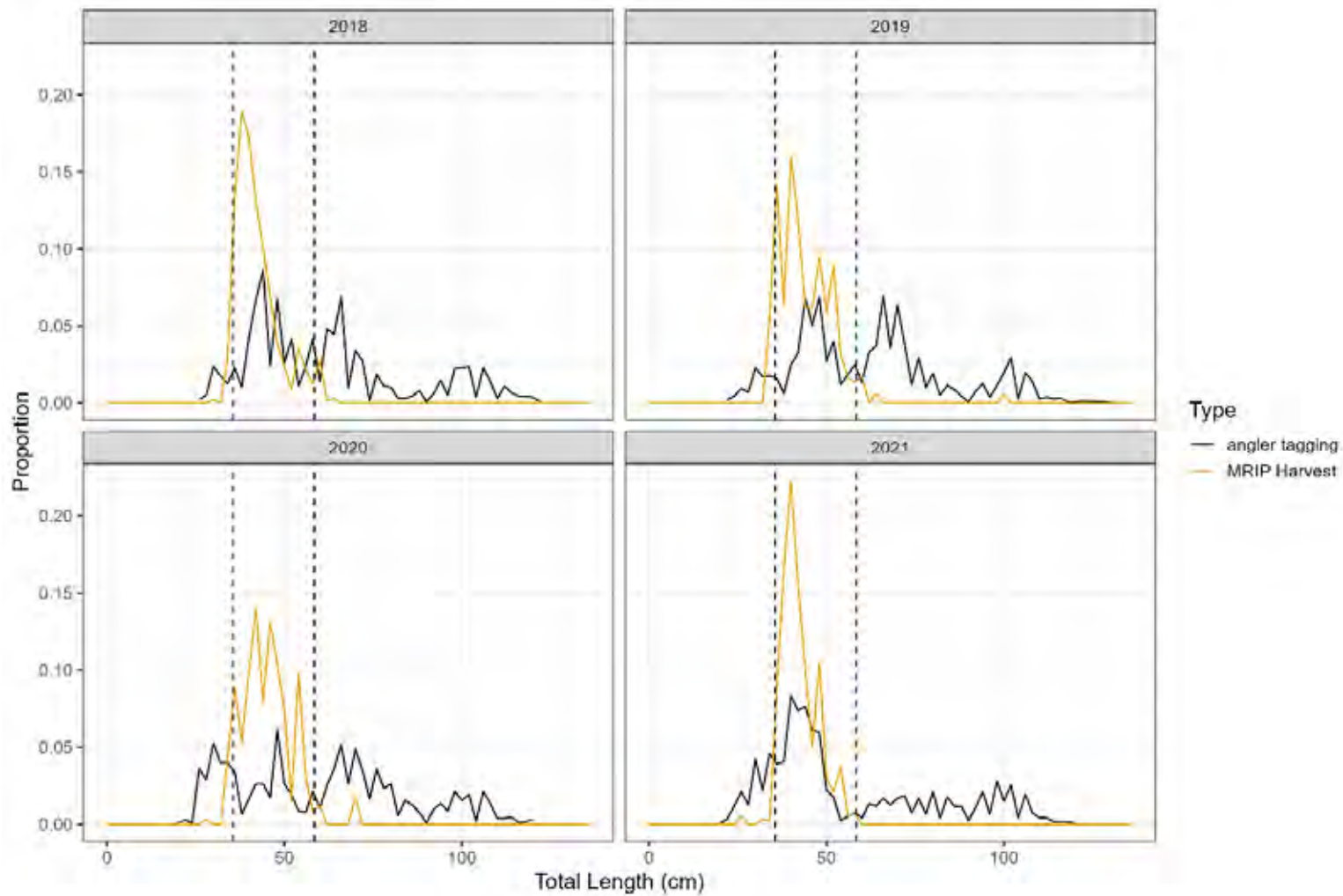


**Figure 61. Size distributions of red drum tagged by volunteer anglers participating in the South Carolina Marine Game Fish Tagging Program and of harvested red drum from MRIP estimates for South Carolina from 1989-1992 and 2011-2021. Horizontal dashed lines indicate slot sizes in place in South Carolina in recent years.**

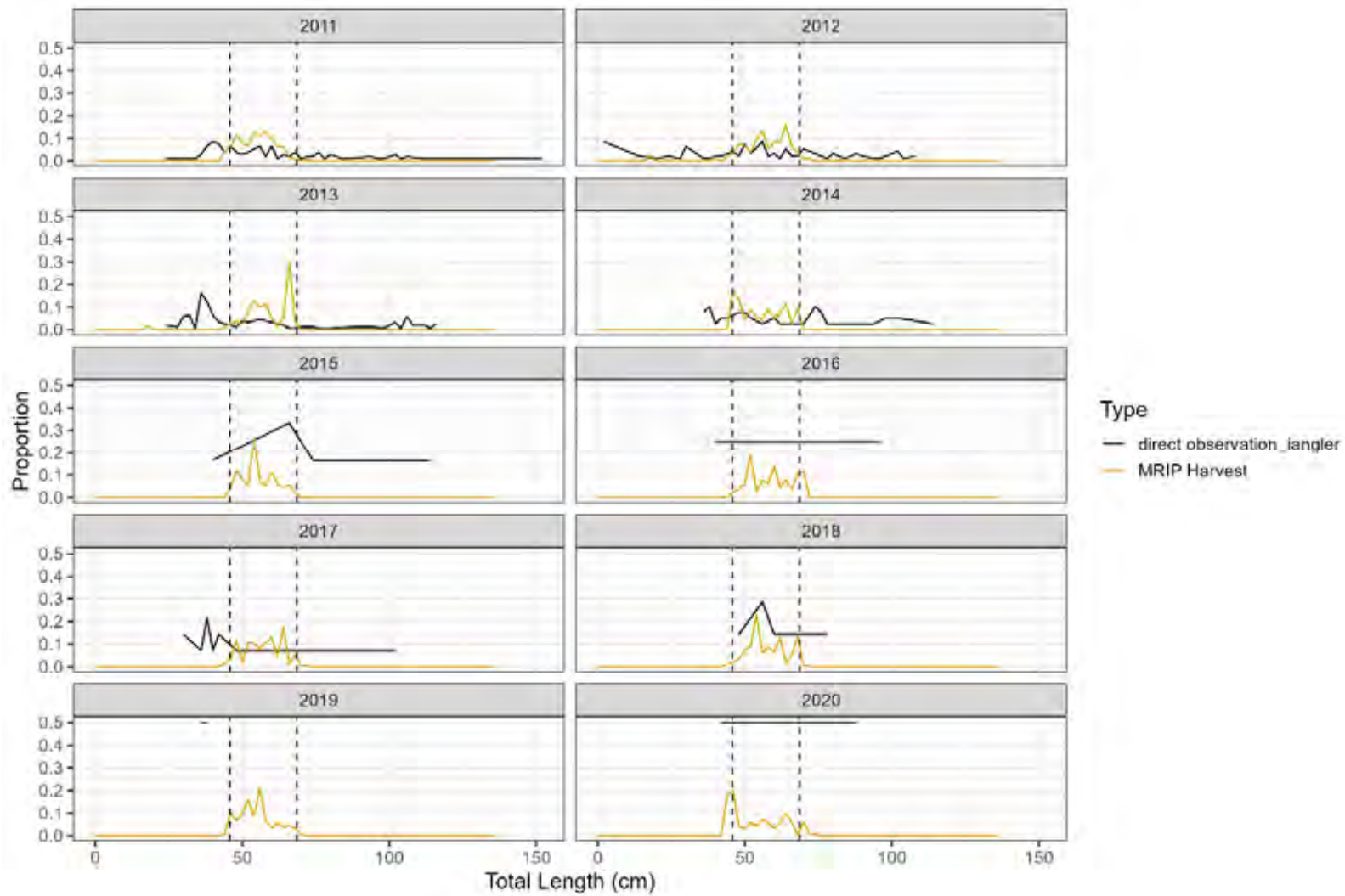


**Figure 62. Size distributions of red drum tagged by volunteer anglers and recaptured and subsequently released by anglers participating in the Georgia Cooperative Angler Tagging Project. Horizontal dashed lines indicate slot size in place in Georgia in recent years.**





**Figure 63. Size distributions of red drum tagged by volunteer anglers participating in the Georgia Cooperative Angler Tagging Project and of harvested red drum from MRIP estimates for Georgia from 2018-2021. Horizontal dashed lines indicate slot sizes in place in Georgia.**



**Figure 64. Size distributions of released red drum reported through the iAngler phone application and of harvested red drum from MRIP estimates for Florida. Horizontal dashed lines indicate slot sizes in place in Florida.**

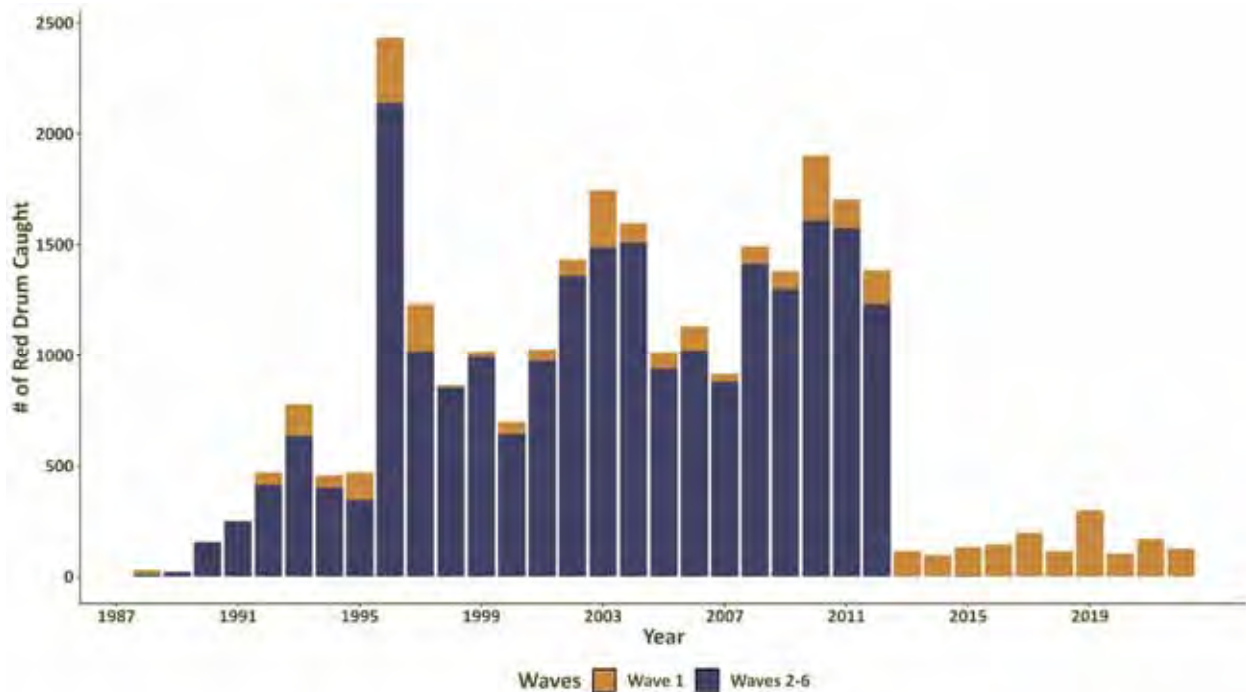


Figure 65. Reported red drum captured during waves 2-6 (March – December; blue bars) and wave 1 (January – February; orange bars) by anglers participating in the SCDNR SFS.

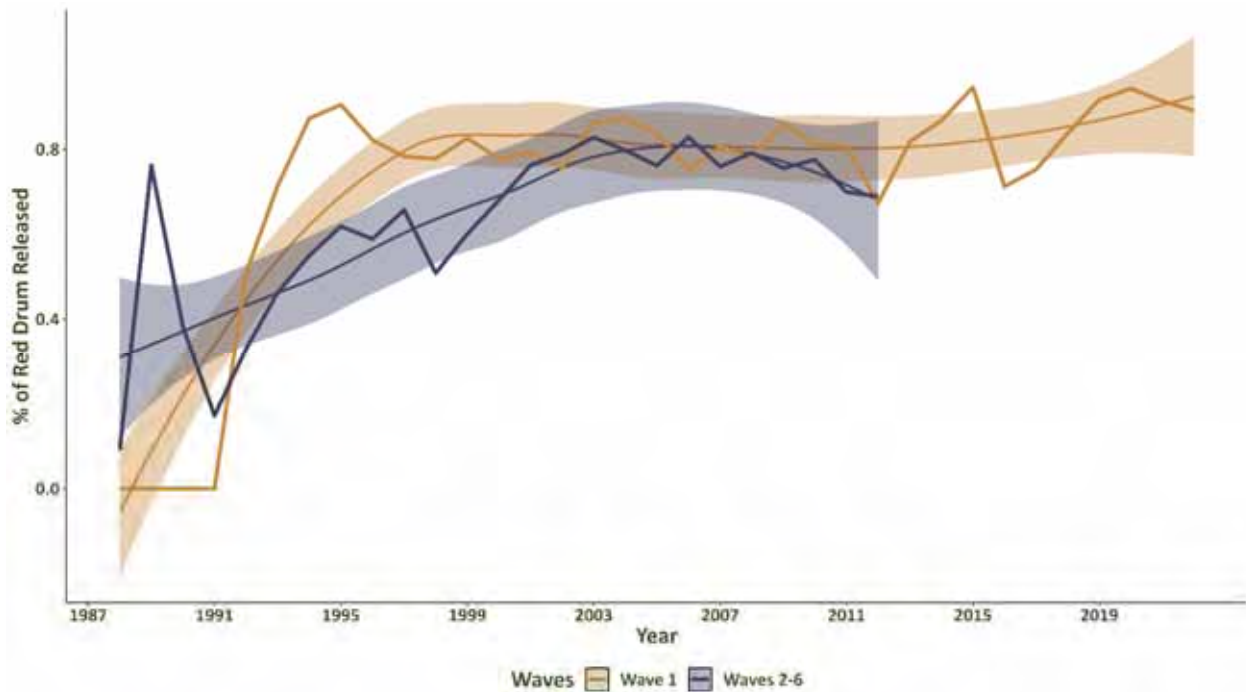


Figure 66. Proportion of red drum released during wave 1 (January – February) and waves 2-6 (March – December) as observed in the SCDNR SFS. Shown are the annual estimates (solid, heavy lines) along with a LOESS smoother of annual estimates with 95% confidence intervals (solid, thin lines with surrounding shaded region).



Figure 67. From top to bottom, the tags above are: Stainless steel anchor “shoulder” dart tags and internal anchor “belly” tags with disk wired to streamer.

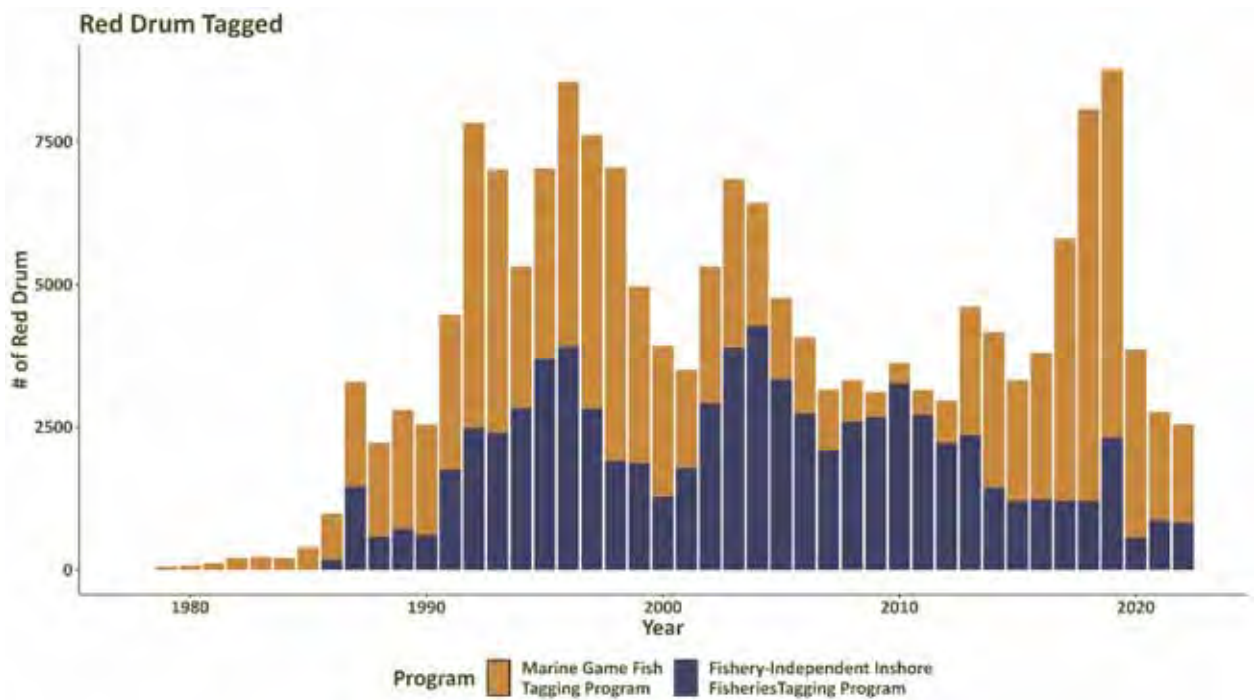


Figure 68. Number of red drum tagged annually in South Carolina by tagging program.

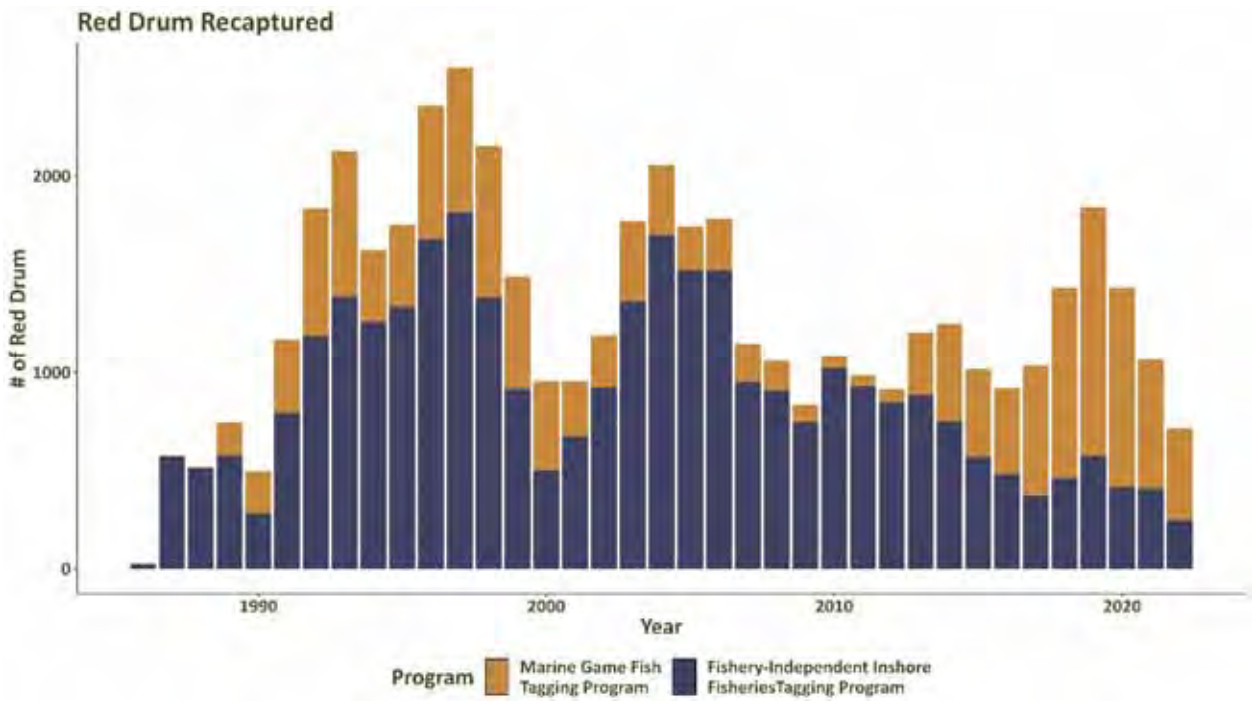


Figure 69. Number of red drum recaptured annually originally tagged as part of SCDNR's conventional tagging program.



Figure 70. Proportion of recaptures released annually for fish tagged as part of the SCDNR conventional tagging programs.

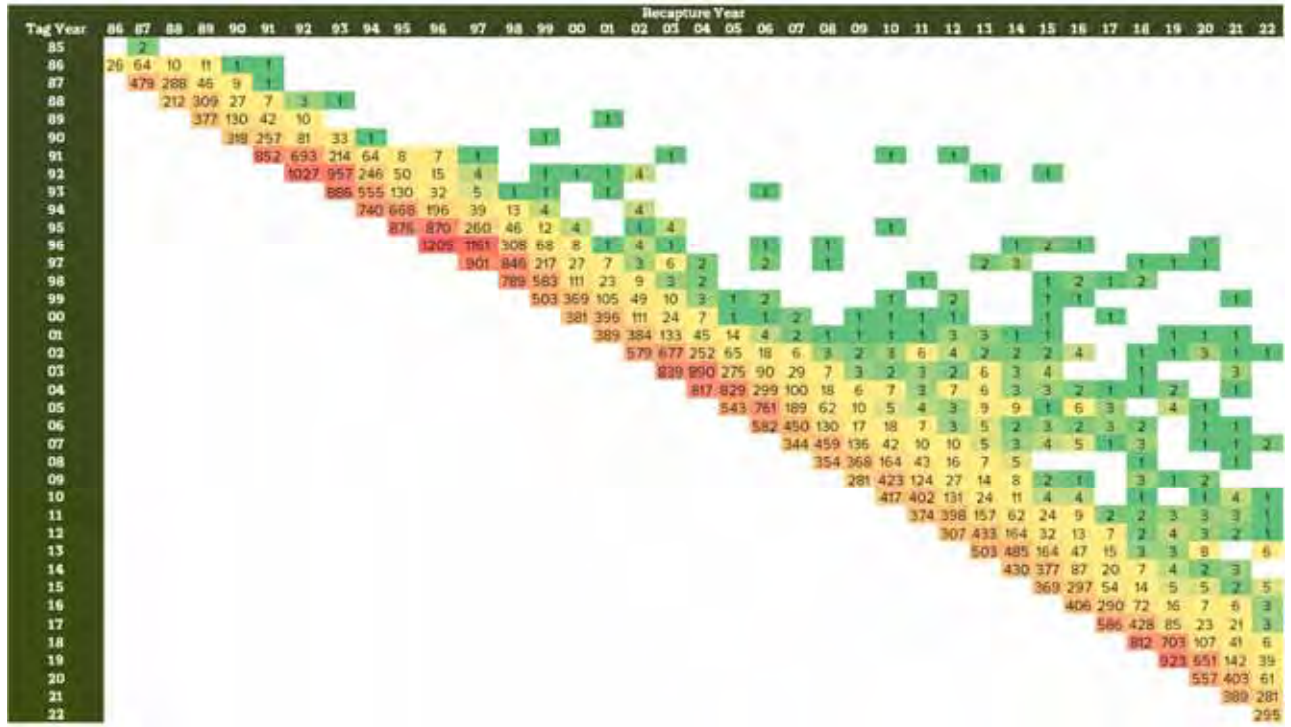


Figure 71. Tag year and recapture year of the >47,800 recaptures of fish tagged as part of the SCDNR conventional tagging program.

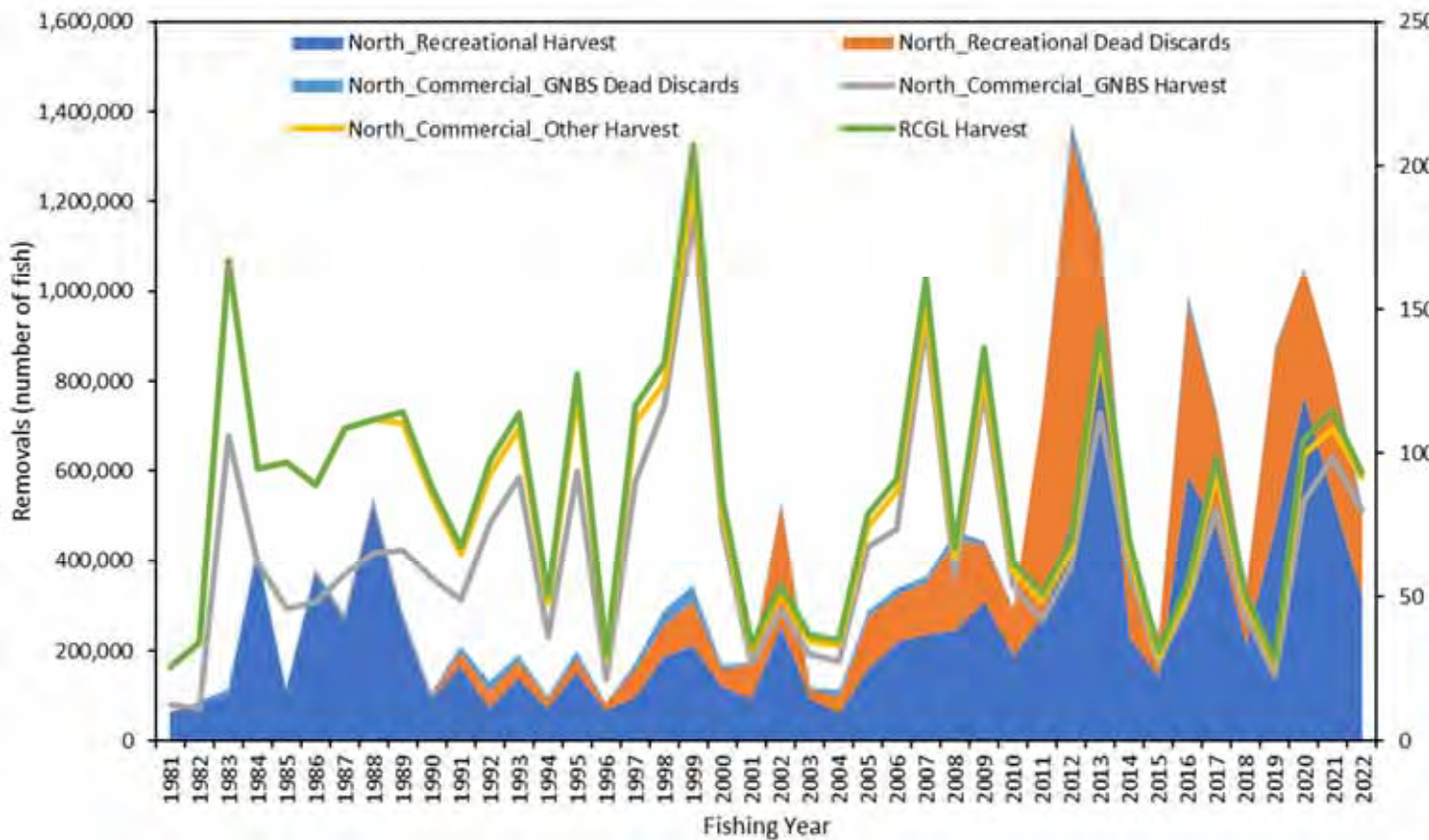


Figure 72. Total fishery removals of northern stock red drum. Stacked area removals are numbers of fish and stacked line removals are metric tons.

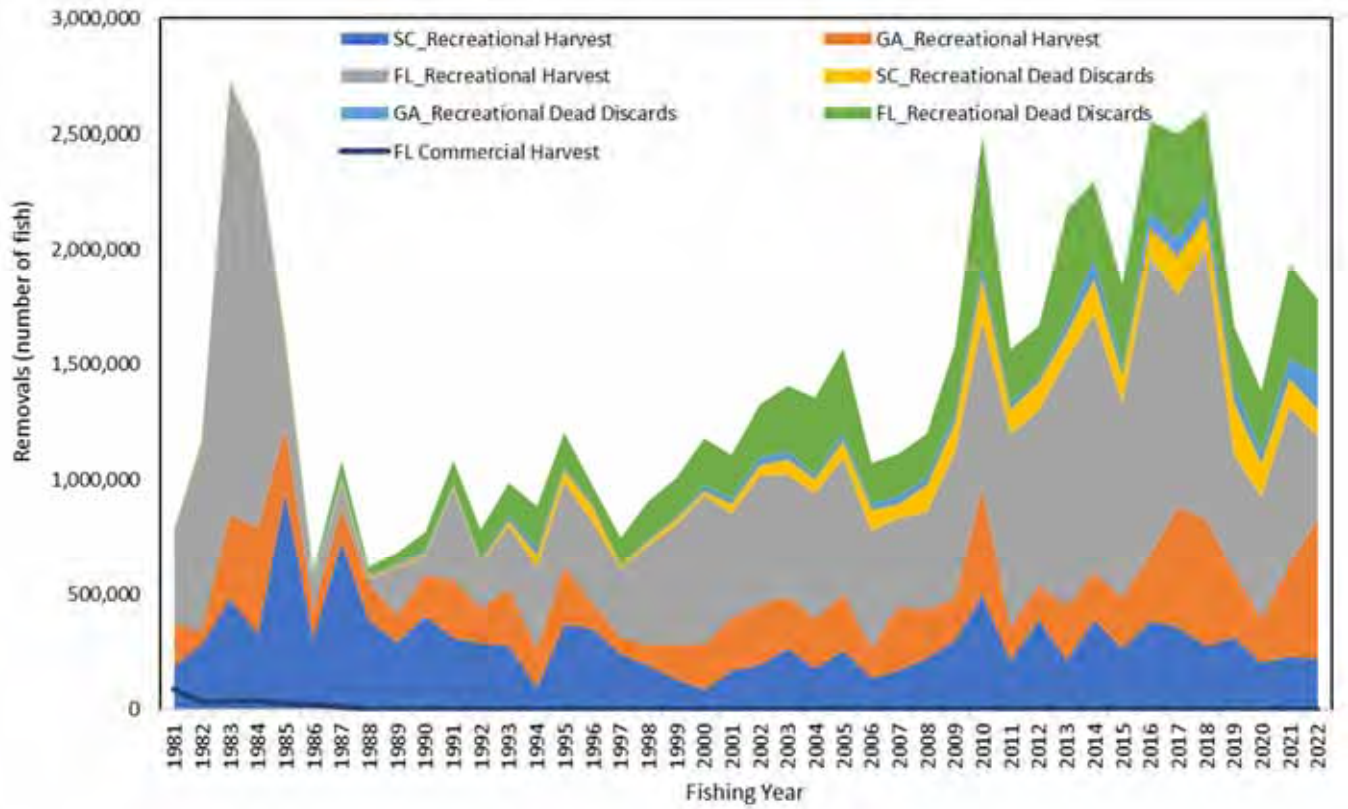


Figure 73. Total fishery removals (stacked area) of southern stock red drum.

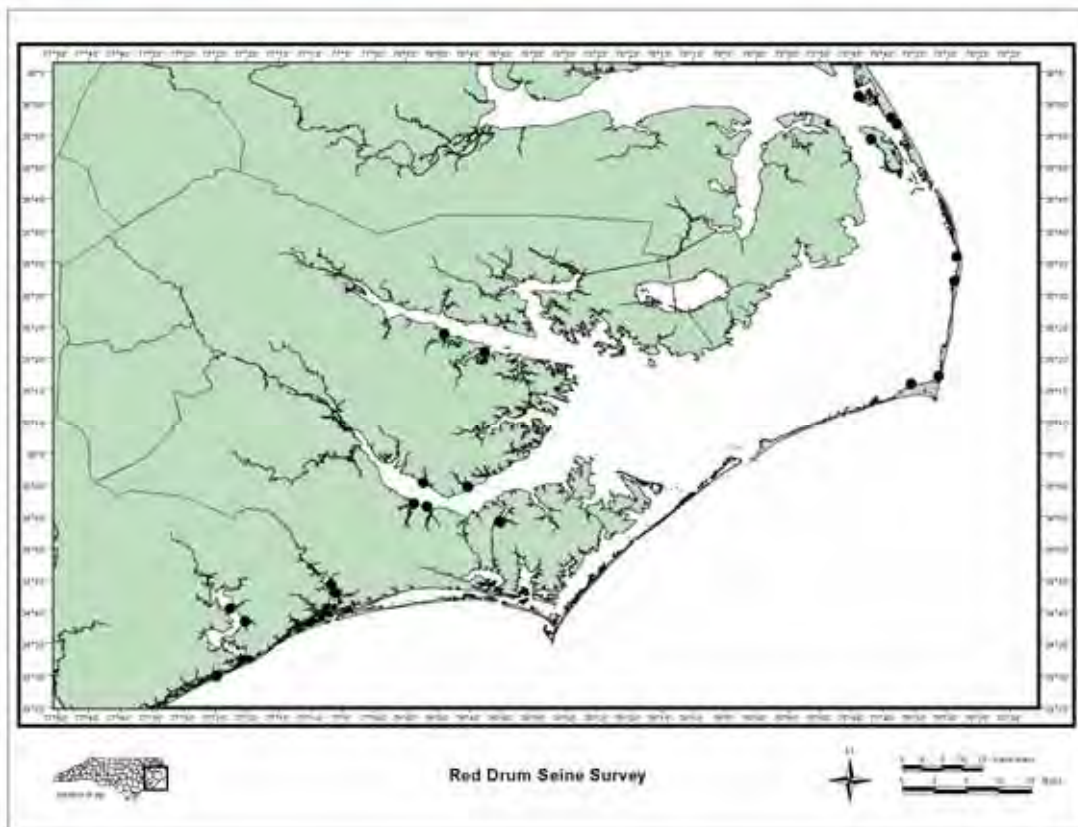
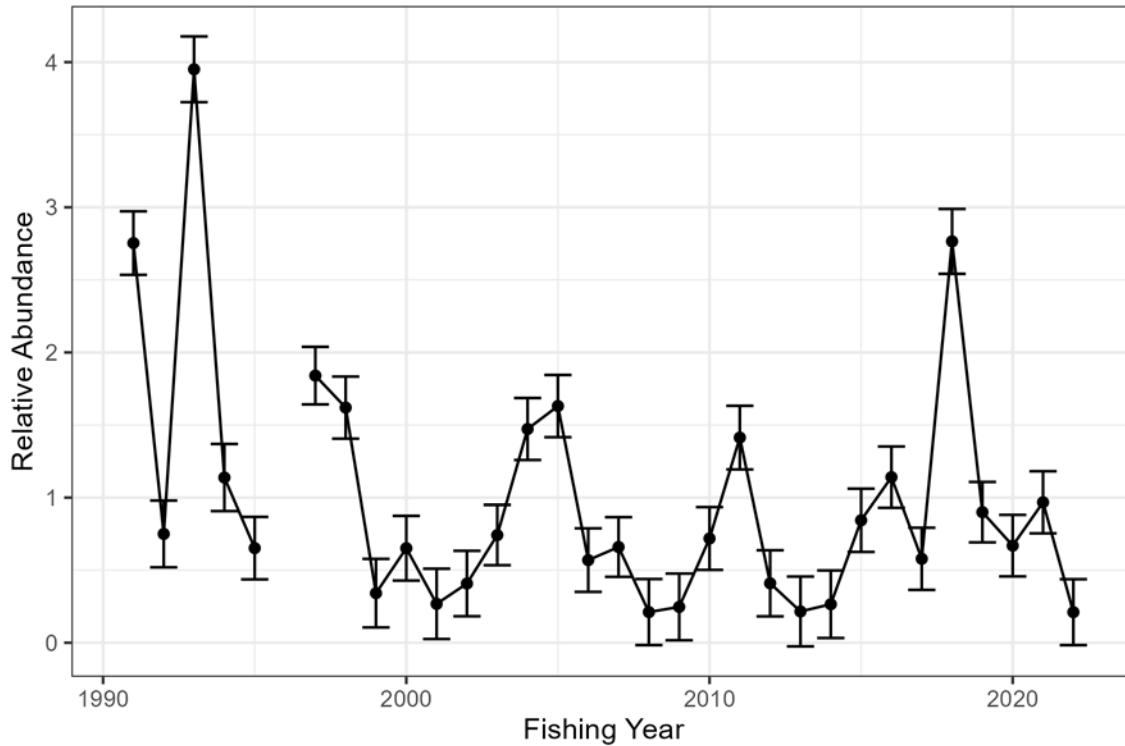
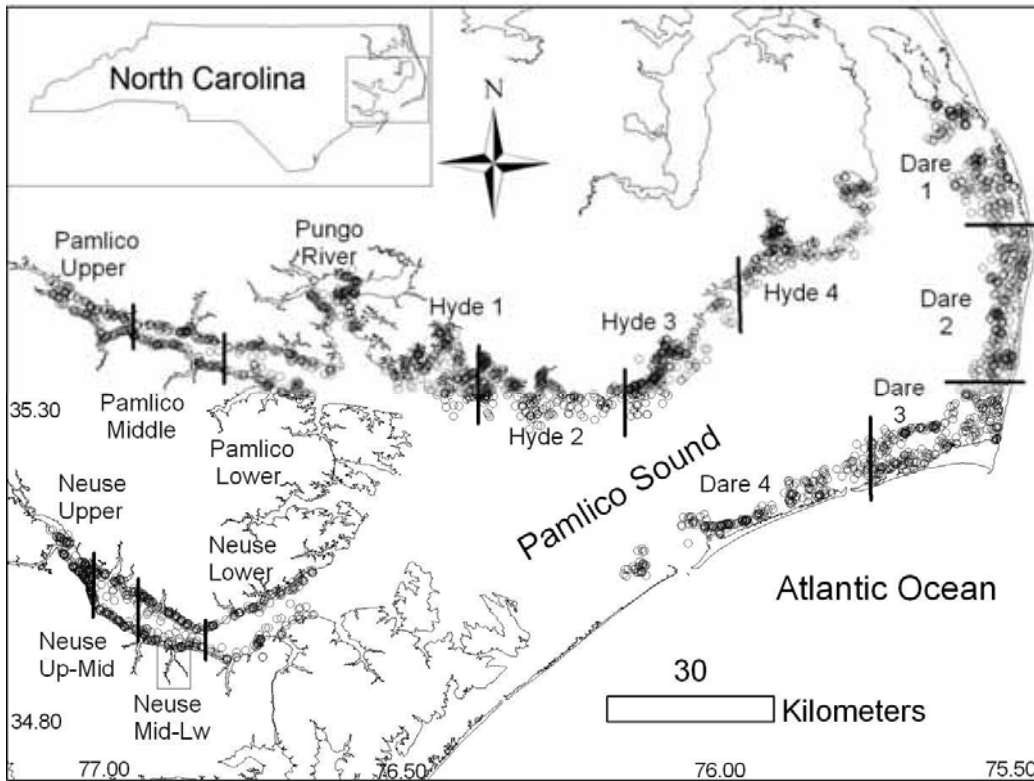


Figure 74. Sampling sites of the North Carolina Bag Seine Survey (NC\_BagSeine)

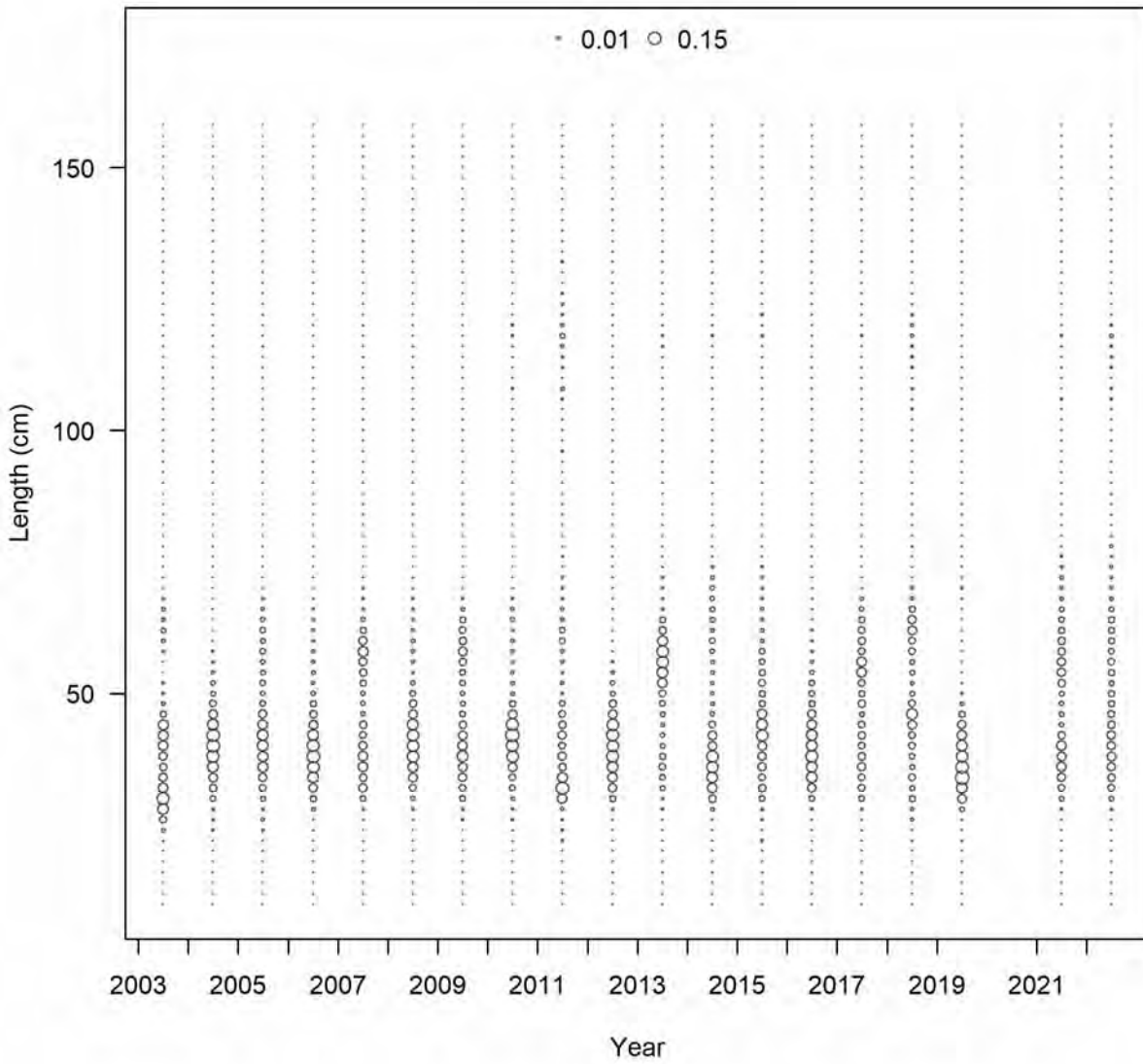


**Figure 75. North Carolina Bag Seine Survey (NC\_BagSeine) relative abundance, standardized to its mean, from 1991-2022. Error bars are  $\pm$  one standard error.**



**Figure 76. Map of Pamlico Sound and associated rivers showing the sample strata and locations of individual samples taken in the North Carolina Independent Gill Net Survey (NC\_GillNet) from 2001 to 2006.**





**Figure 77. Length compositions of red drum captured during the North Carolina Independent Gill Net Survey (NC\_GillNet).**

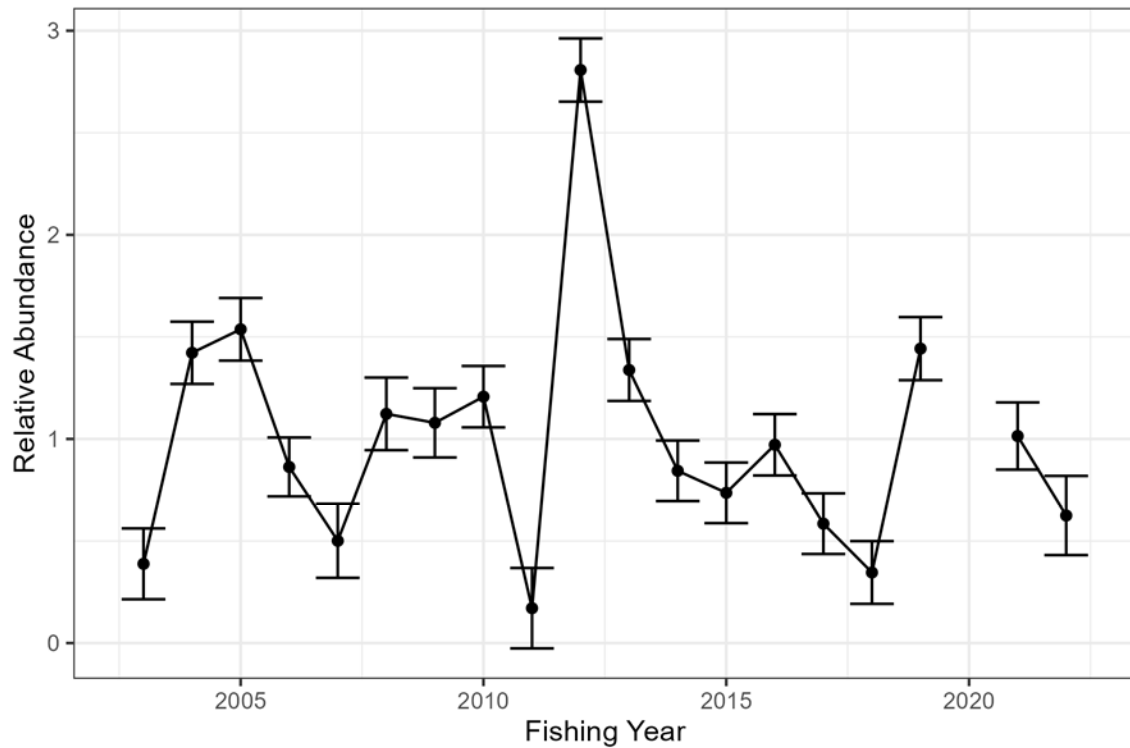


Figure 78. North Carolina Independent Gill Net Survey (NC\_GillNet) relative abundance, standardized to its mean, from 2003-2022. Error bars are  $\pm$  one standard error.

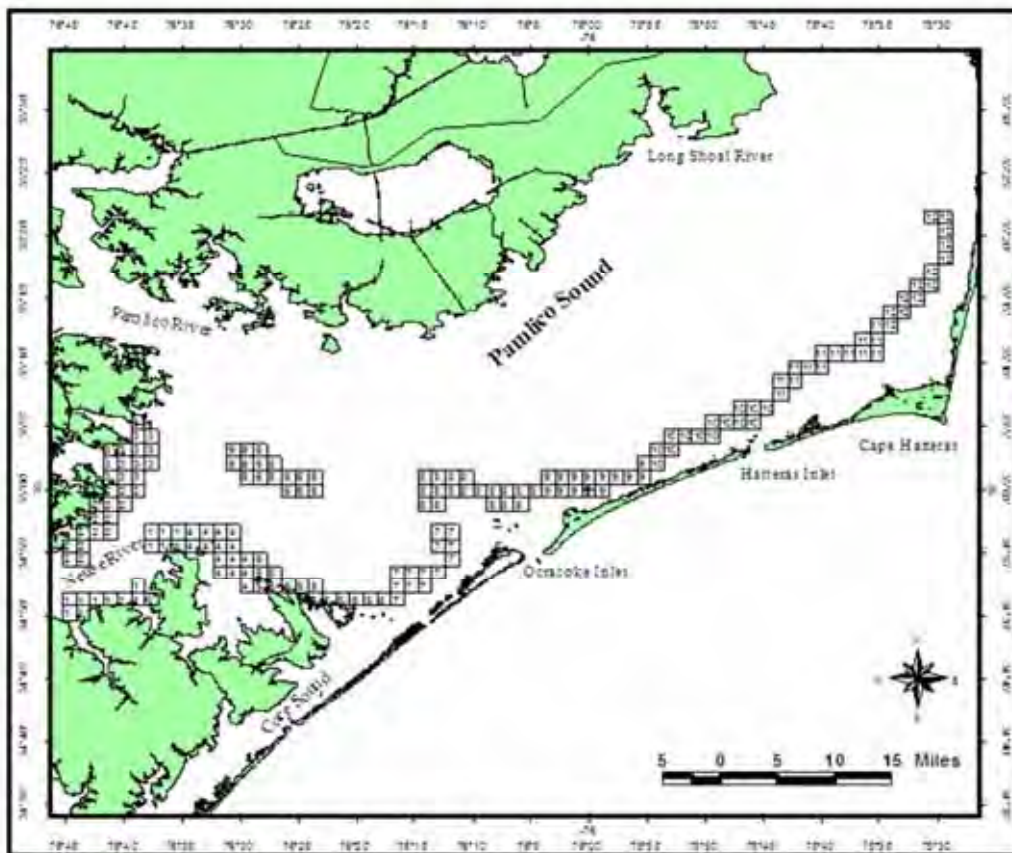
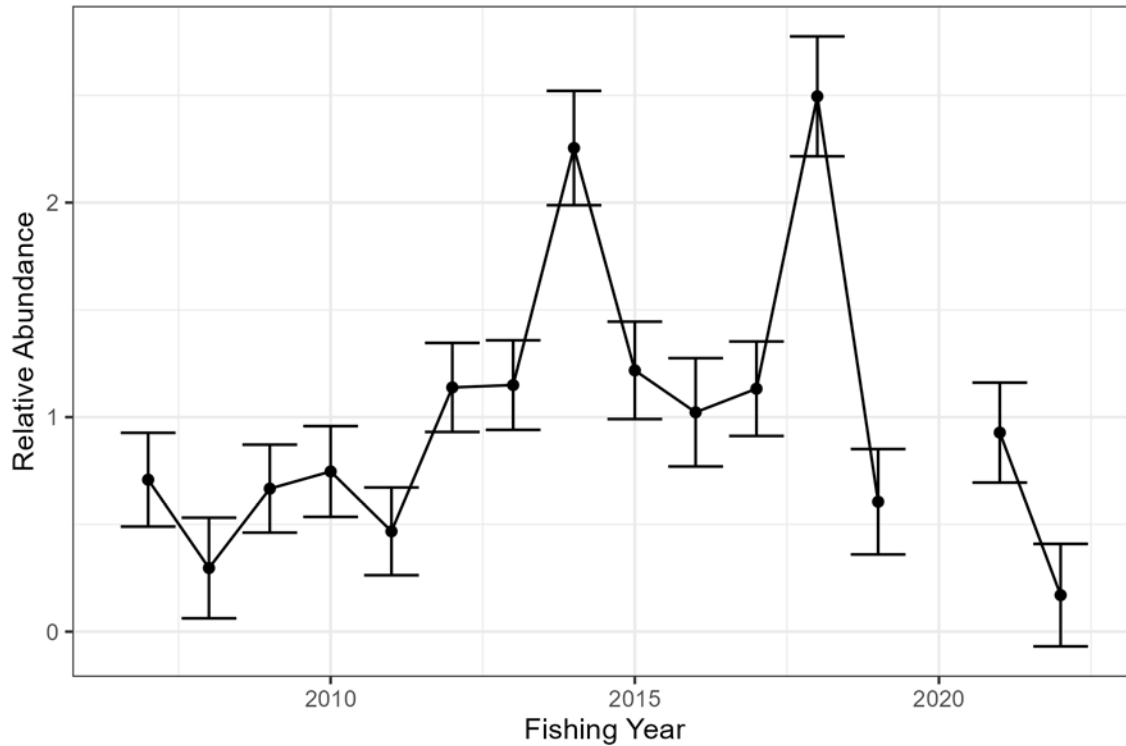
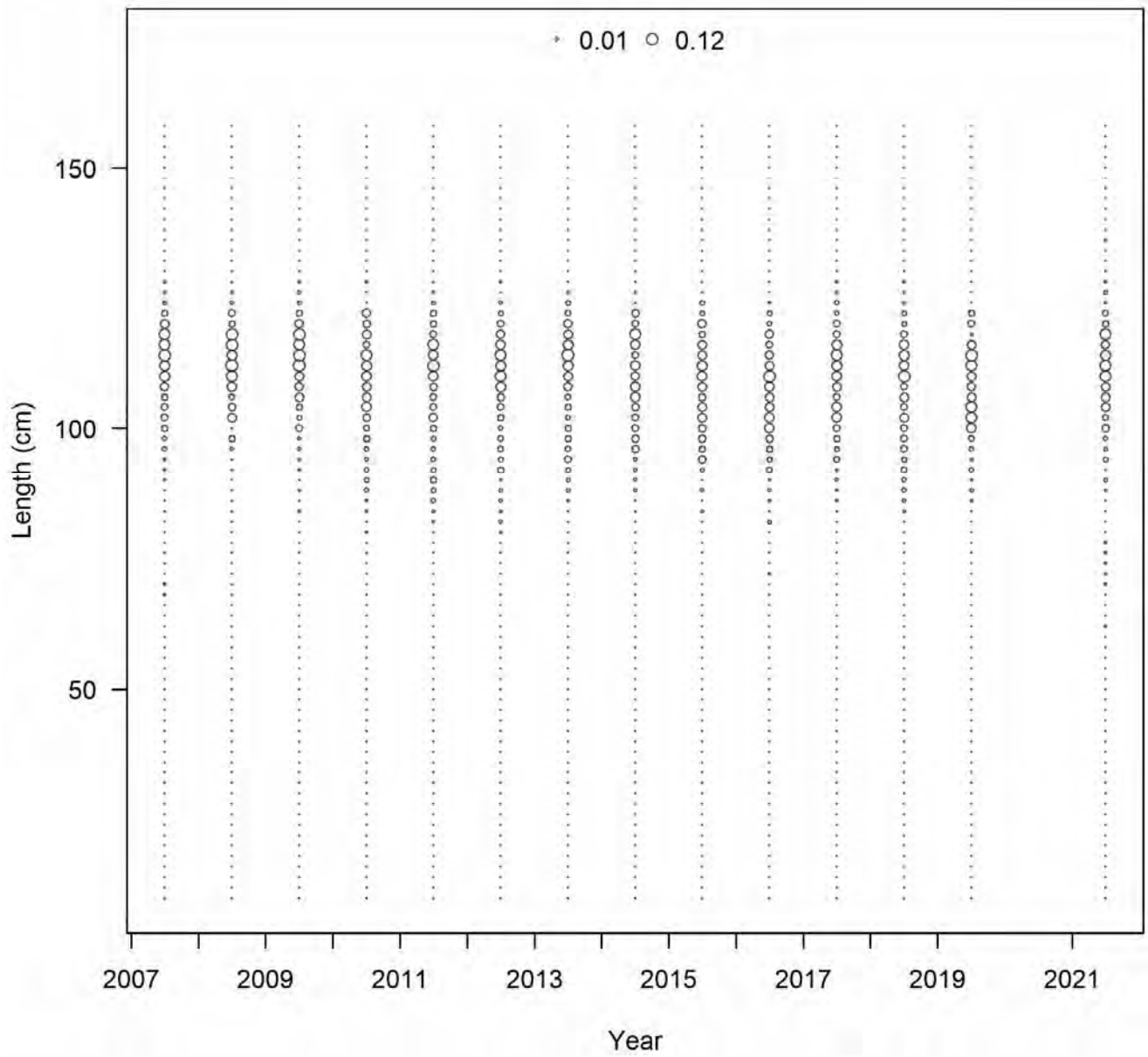


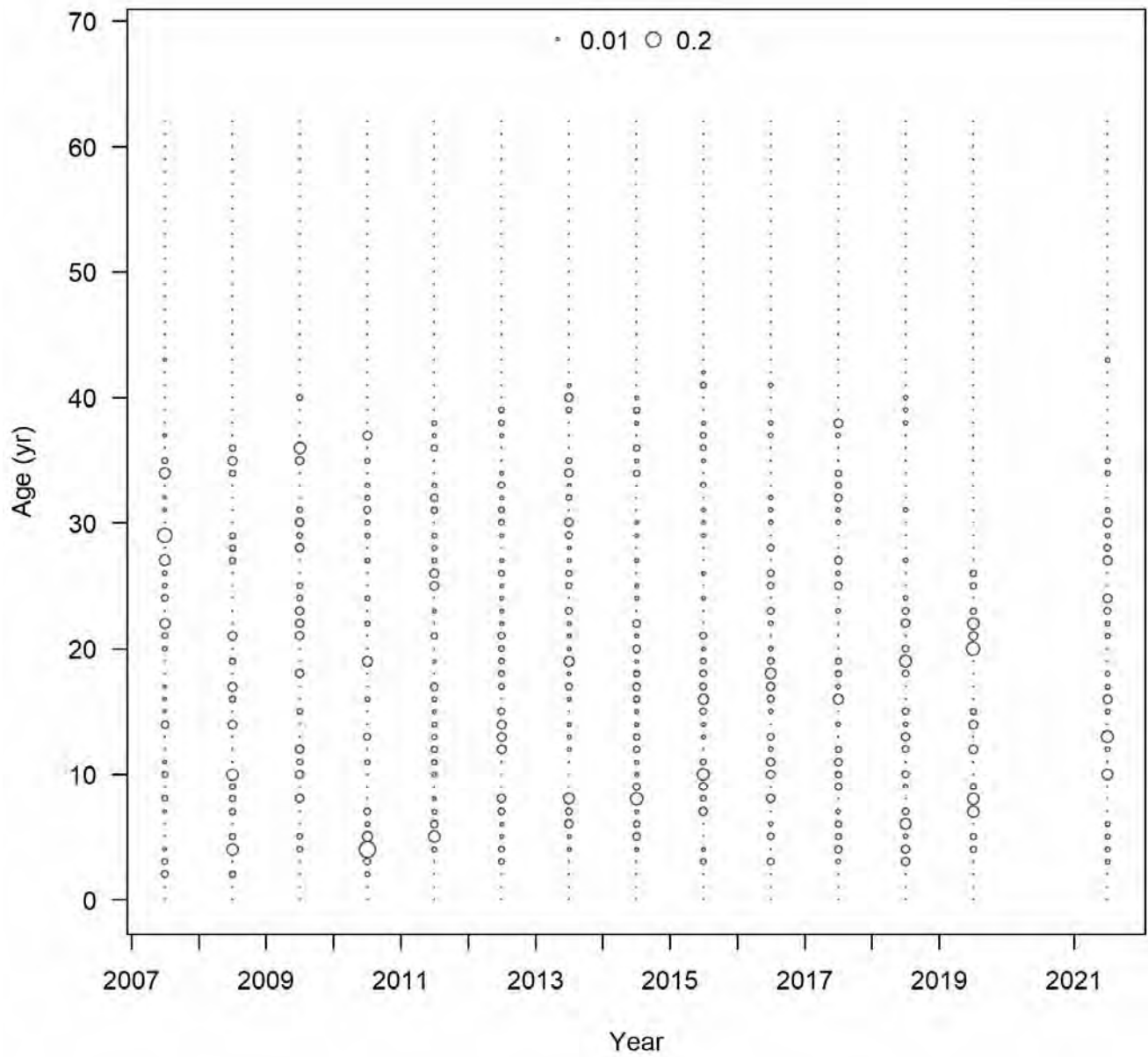
Figure 79. The random grid system and sample regions used in the North Carolina red drum Longline Survey used from 2007 to 2022. The numeric value in each grid designates it to one of the twelve regions sampled.



**Figure 80. North Carolina Adult Longline Survey (NC\_Longline) relative abundance, standardized to its mean, from 2007-2022. Error bars are  $\pm$  one standard error.**



**Figure 81. Length compositions of red drum captured during the North Carolina Adult Longline Survey (NC\_Longline).**



**Figure 82. Age distribution of red drum captured during the North Carolina Adult Longline Survey (NC\_Longline).**

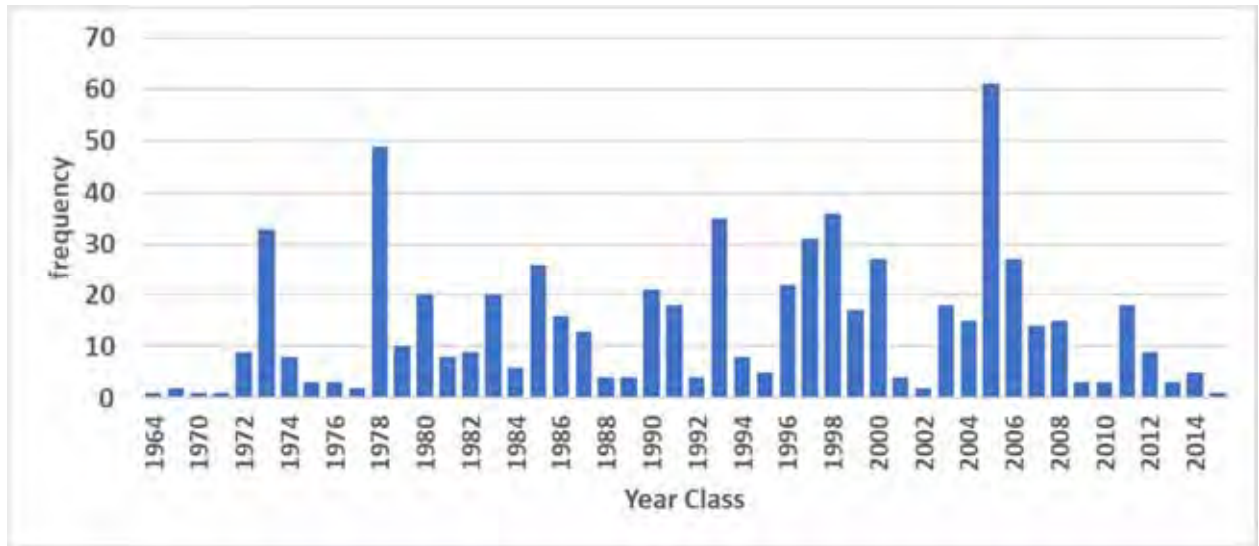


Figure 83. Frequency of individuals by year class (cohort) collected in the North Carolina Adult Longline Survey (NC\_Longline) from 2007 to 2019.

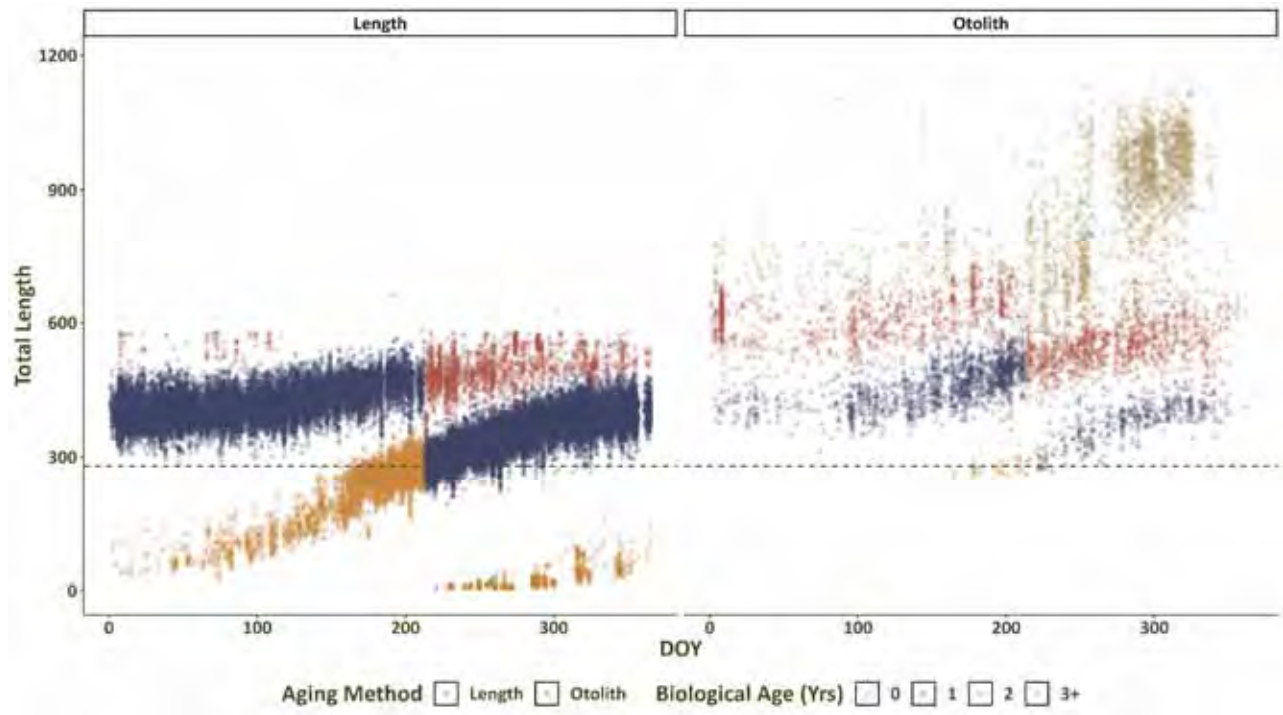


Figure 84. Length distribution, based on calendar year (Jan. 1 – Dec. 31), ageing methodology, and day of year of sampling, of red drum encountered by the SCDNR fishery-independent and fishery-dependent sampling programs. Ages are based on biological age, assuming a September 1 birthday. Note, any fish with age determined using scales have been omitted.

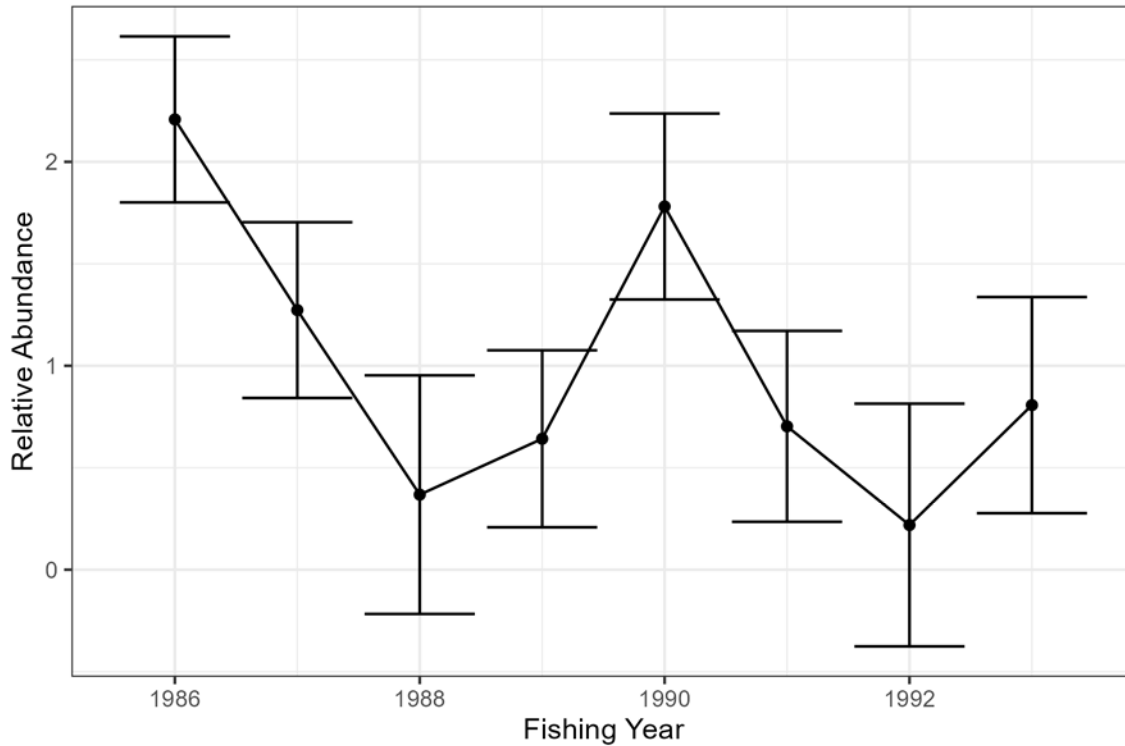


Figure 85. South Carolina Rotenone Survey (SC\_Rotenone) relative abundance, standardized to its mean, from 1986-1993. Error bars are  $\pm$  one standard error.

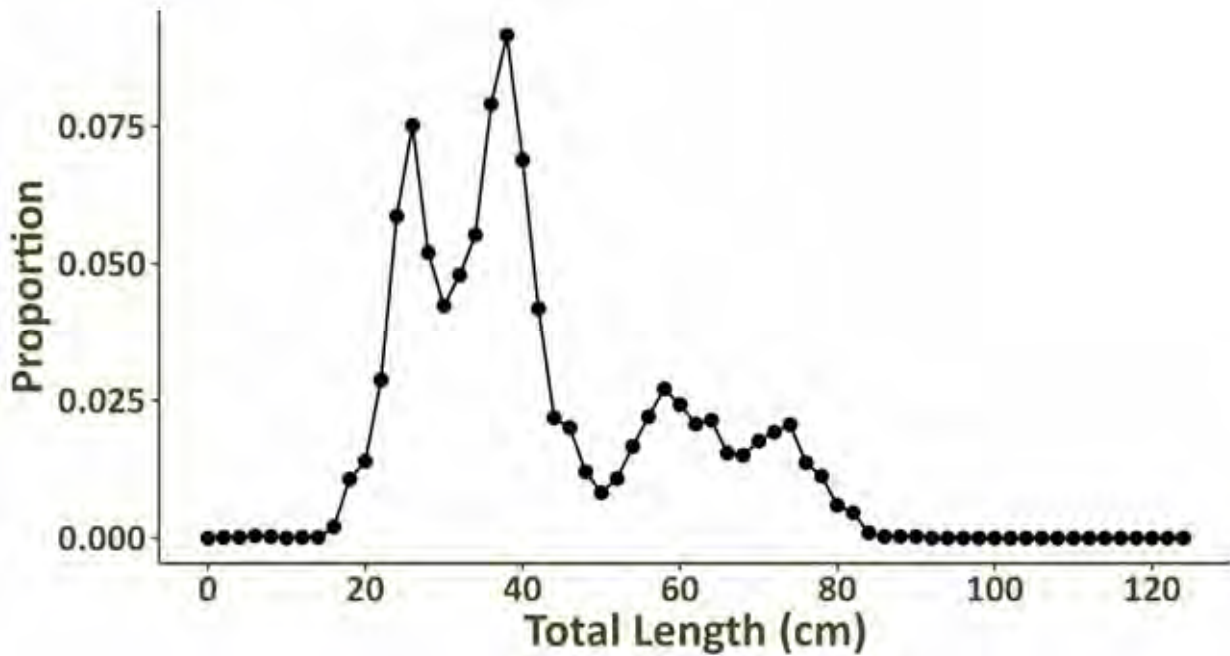


Figure 86. Length composition of red drum encountered by the South Carolina Stop Net Survey (SC\_StopNet) when pooled across all years.

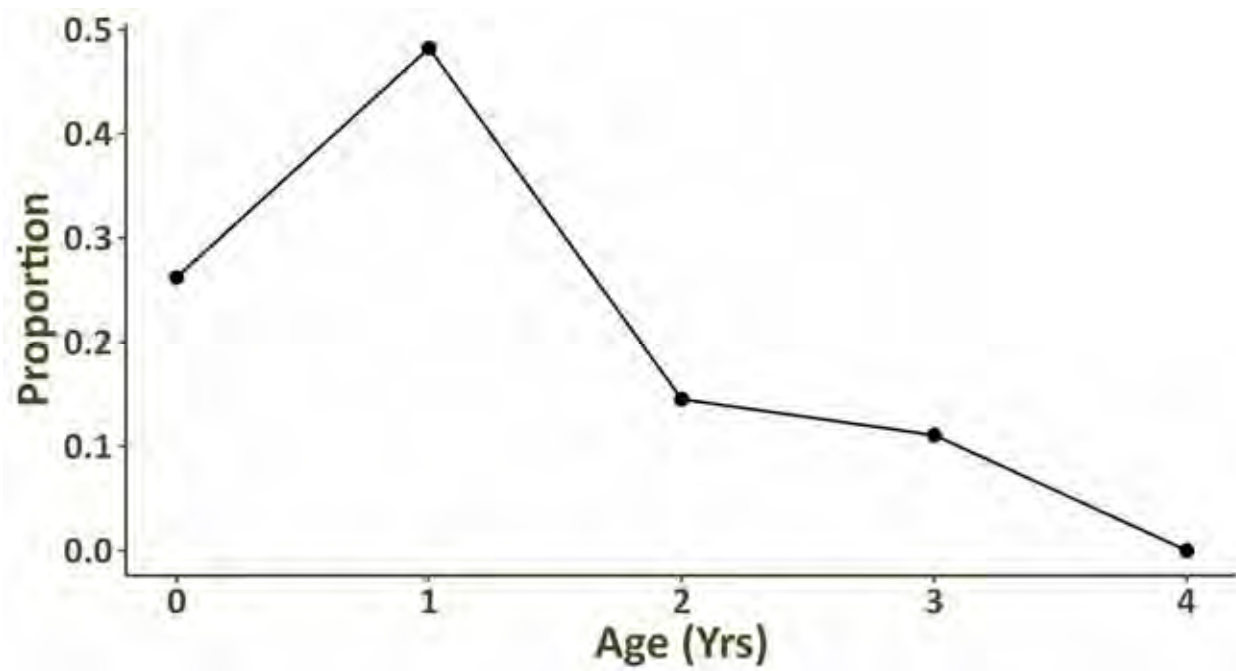


Figure 87. Age composition of red drum encountered by the South Carolina Stop Net Survey (SC\_StopNet) when pooled across all years. Age 4 represents an age-4+ group.

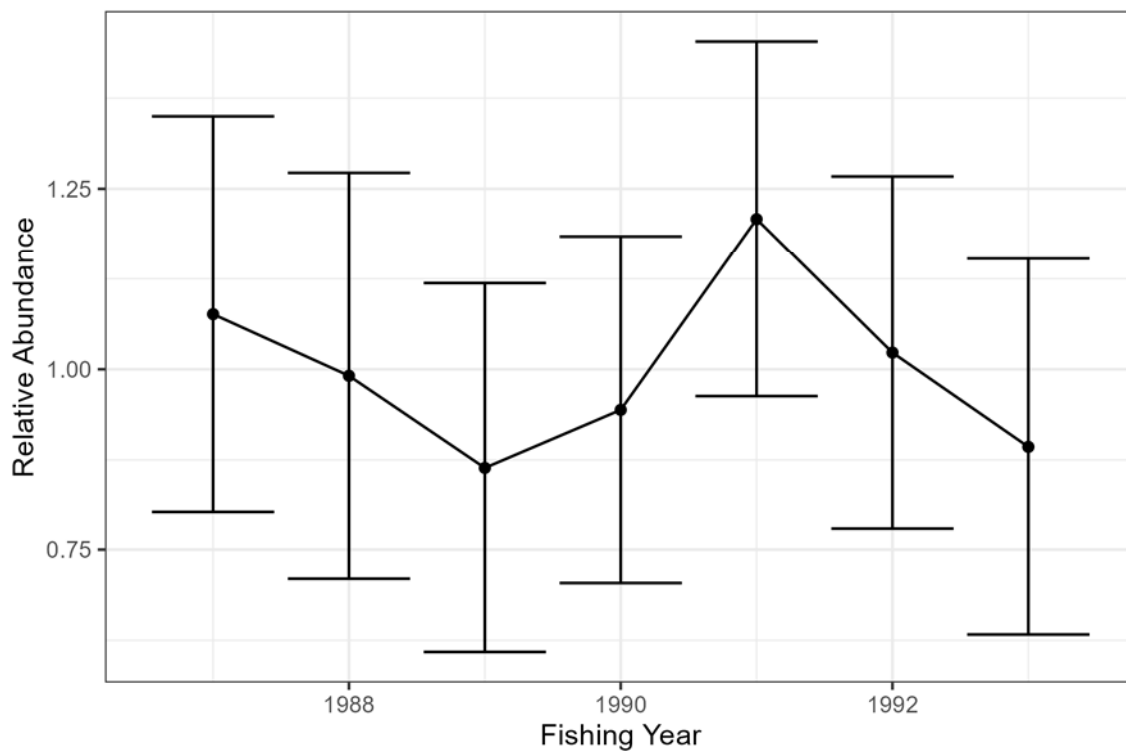
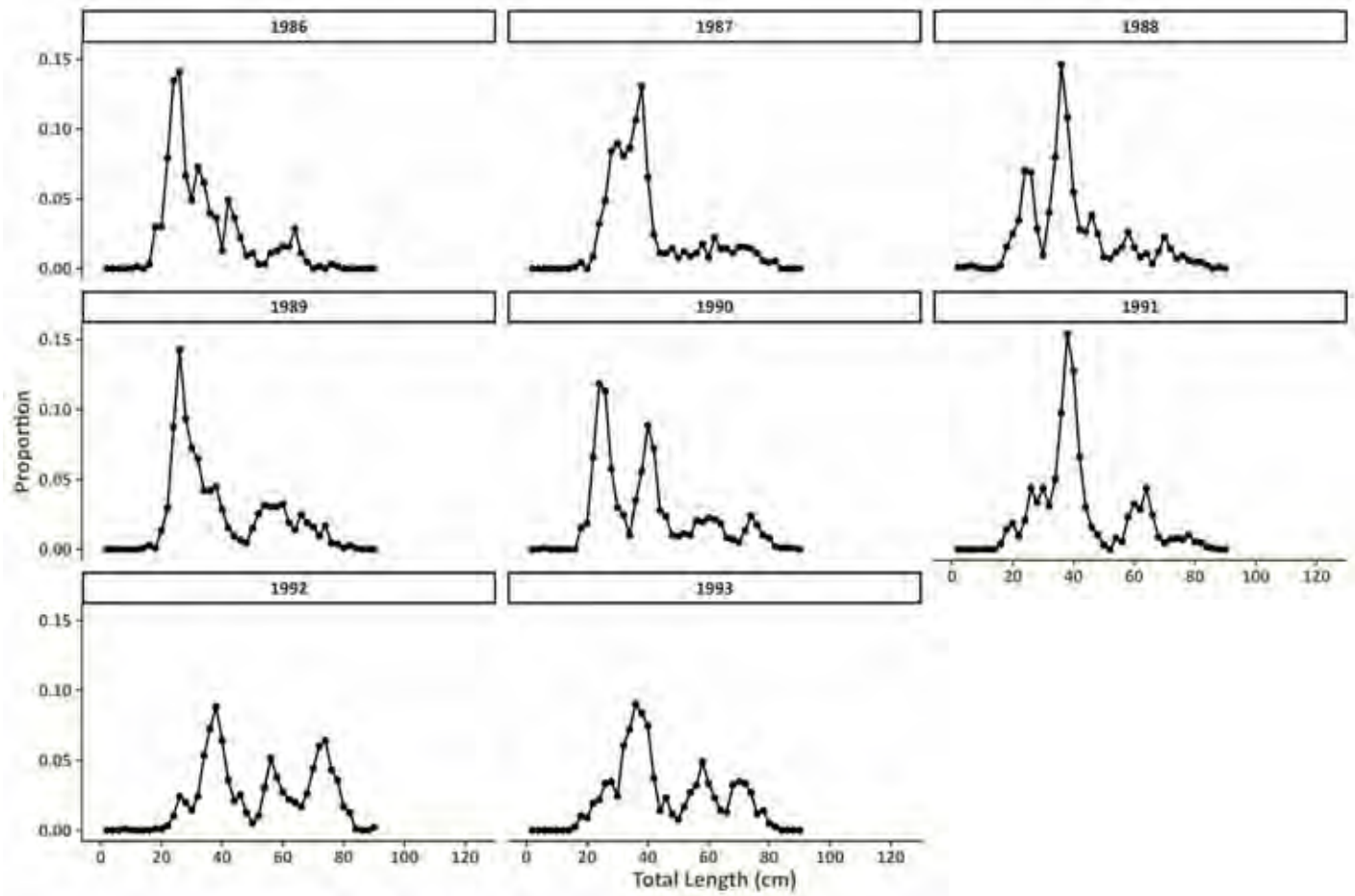
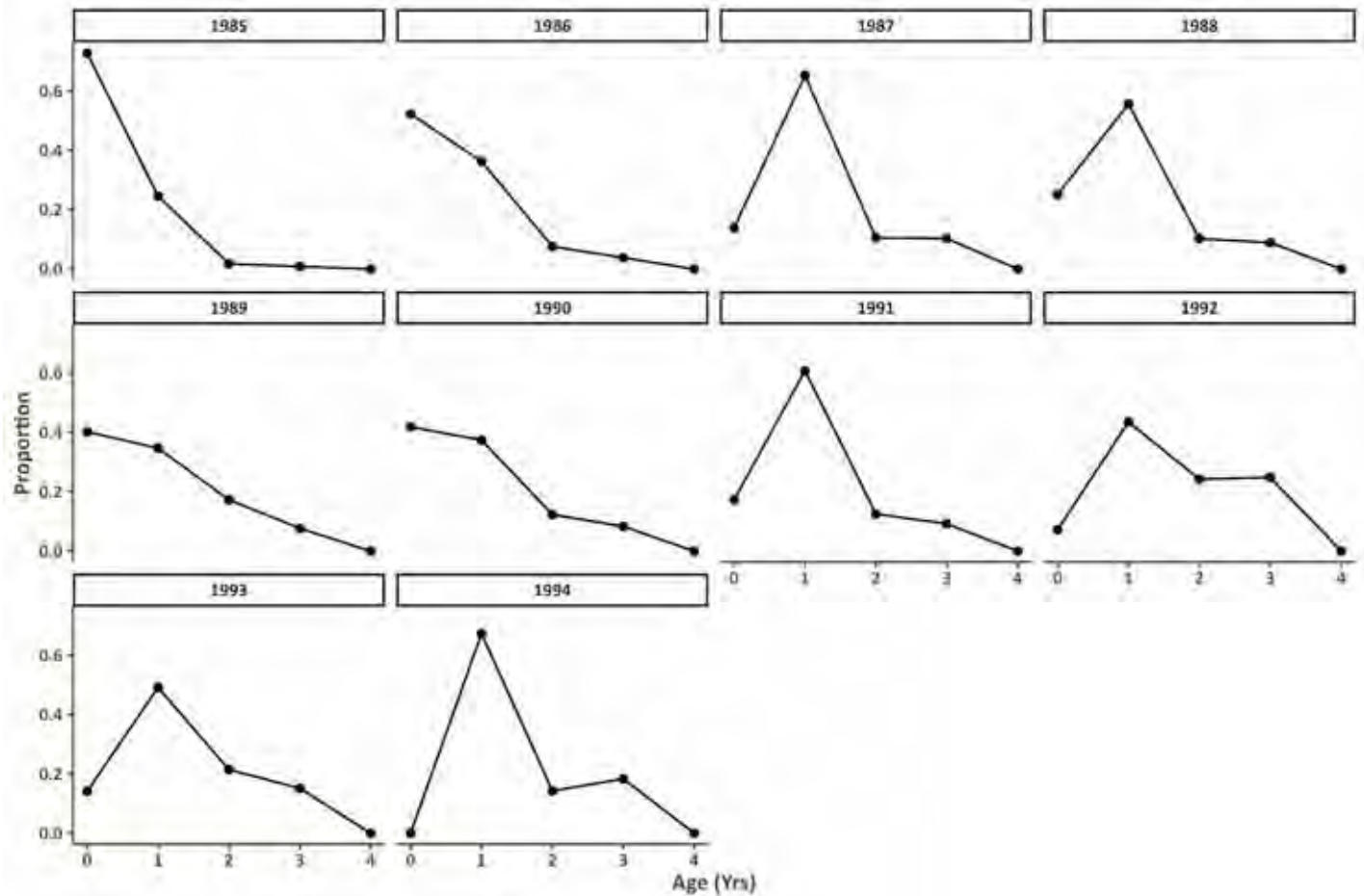


Figure 88. South Carolina Stop Net Survey (SC\_StopNet) relative abundance, standardized to its mean, from 1987-1993. Error bars are  $\pm$  one standard error.





**Figure 89. Annual length compositions developed for the South Carolina Stop Net Survey (SC\_StopNet).**



**Figure 90. Annual age compositions developed for the South Carolina Stop Net Survey (SC\_StopNet). Note, age represents biological age assuming a September 1 birthday and age-4 represents a 'plus' group.**

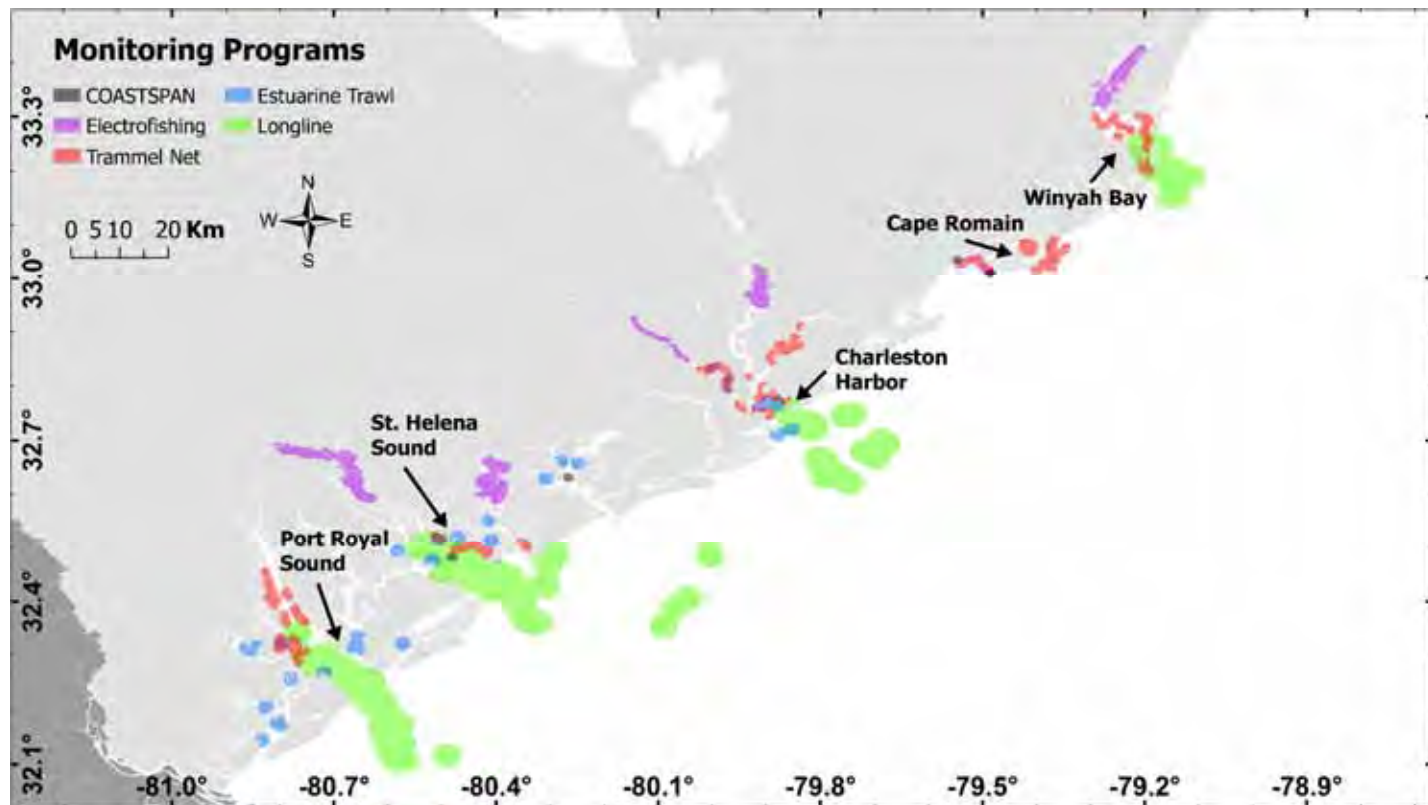


Figure 91. Sampling distribution of the South Carolina Trammel Net Survey (SC\_Trammel; red shaded areas), South Carolina Electrofishing Survey (SC\_Electro; purple shaded areas) and South Carolina Contemporary Longline Survey (SC\_Longline\_contemporary; green shaded areas) surveys. Also identified are two additional contemporary fishery-independent finfish surveys that do not regularly encounter red drum, SCDNR's COASTSPAN (gray shaded areas) and estuarine trawl (blue shaded areas) surveys. Identified are the five major South Carolina estuaries, from Port Royal Sound in the south to Winyah Bay in the north.

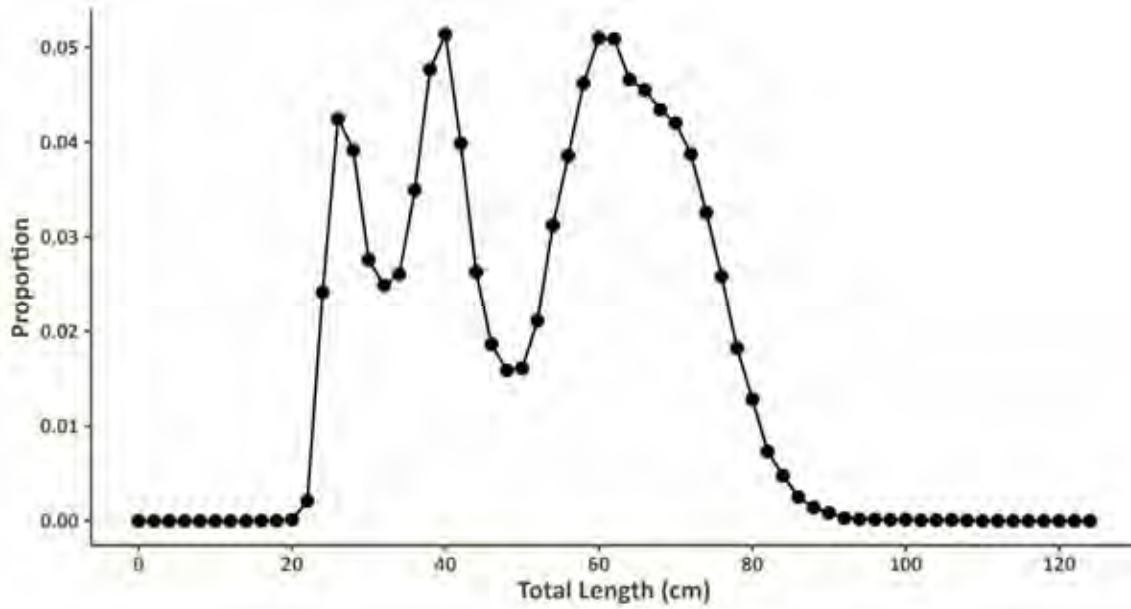


Figure 92. Length composition of red drum encountered by the South Carolina Trammel Net Survey (SC\_Trammel) when pooled across all years.

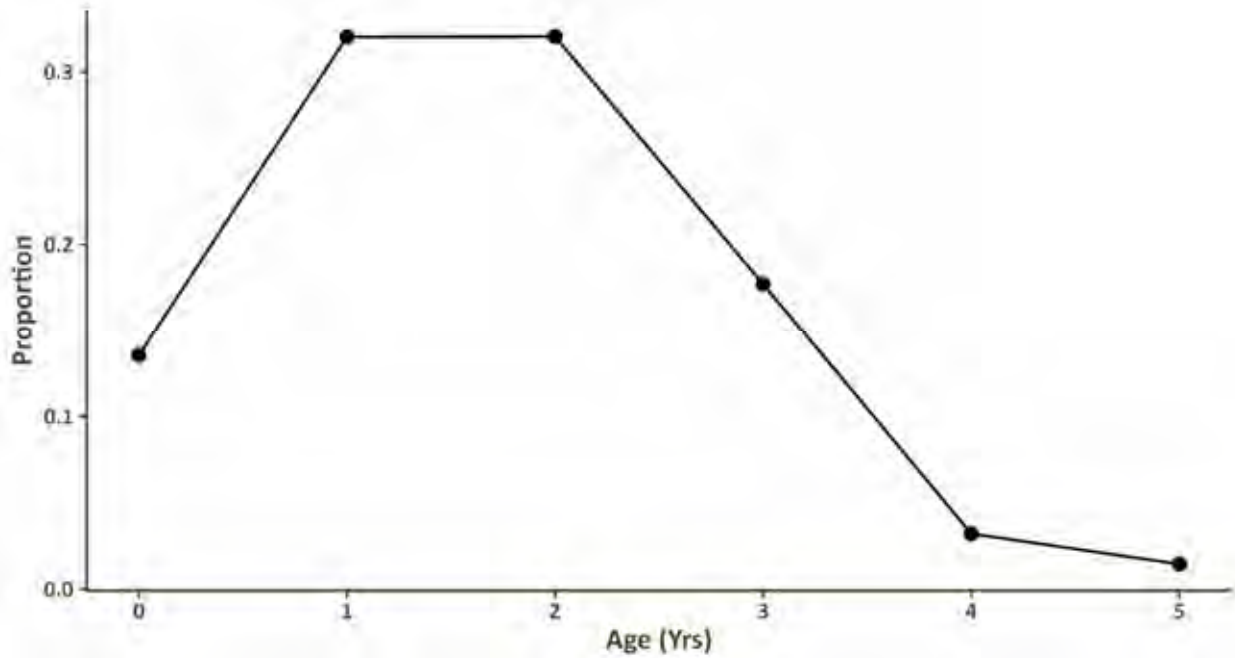
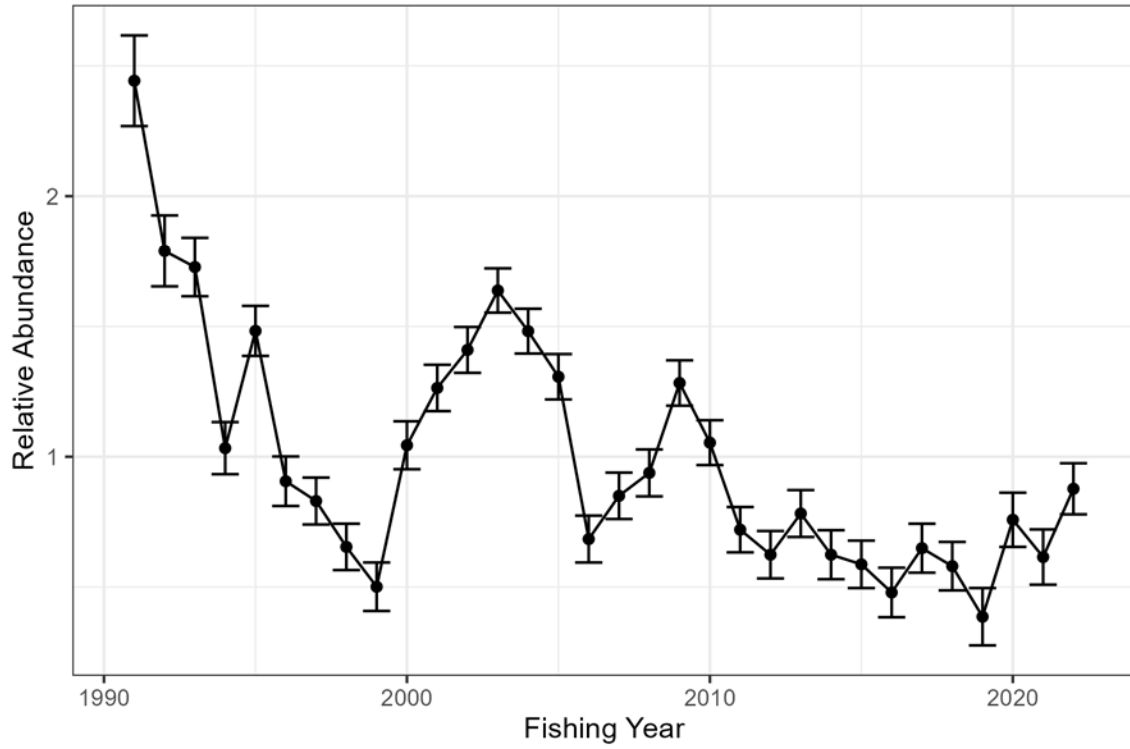


Figure 93. Age composition of red drum encountered by the South Carolina Trammel Net Survey (SC\_Trammel) when pooled across all years. Age 5 represents an age 5+ group.



**Figure 94. South Carolina Trammel Net Survey (SC\_Trammel) relative abundance, standardized to its mean, from 1991-2022. Error bars are  $\pm$  one standard error.**

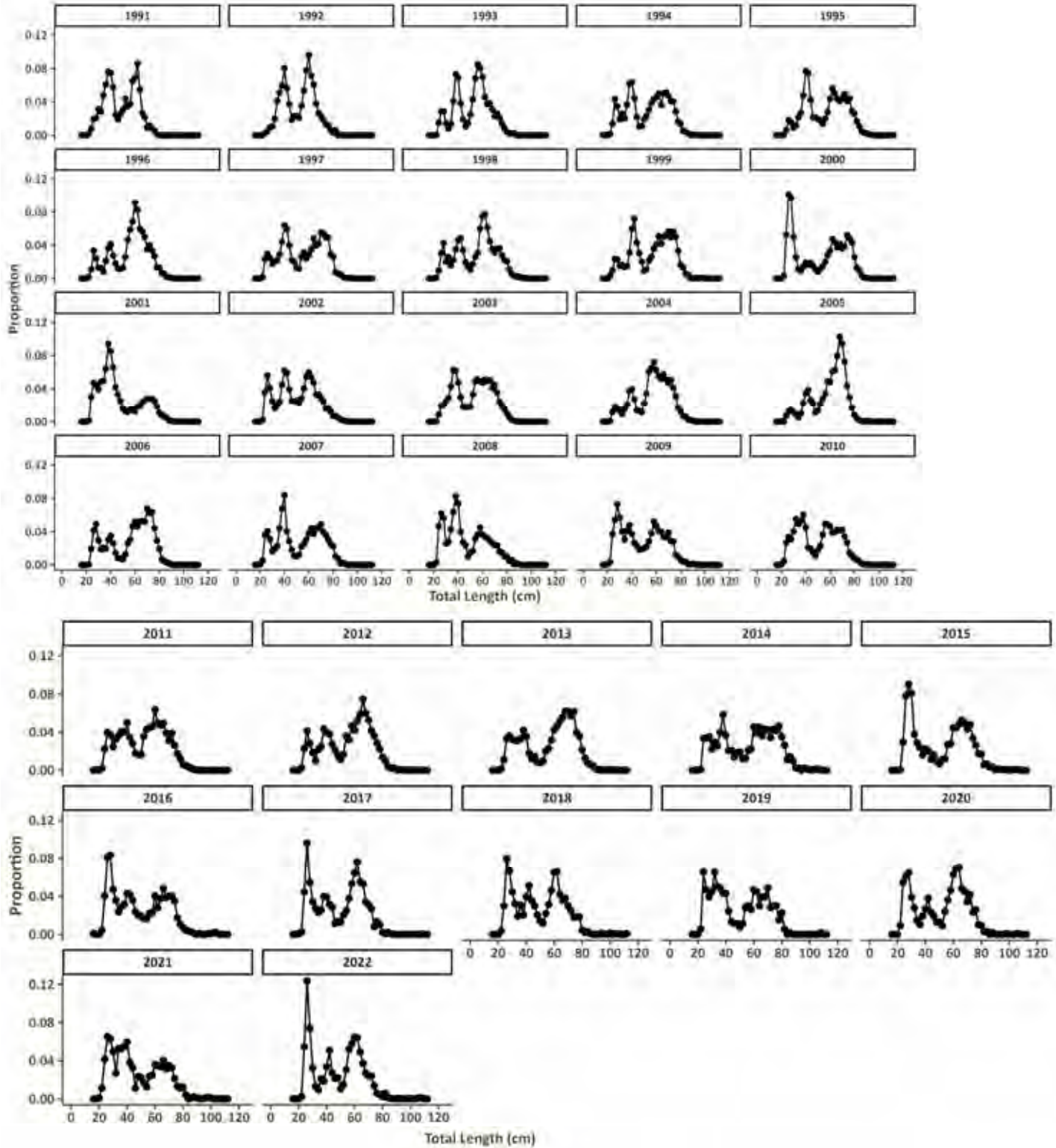
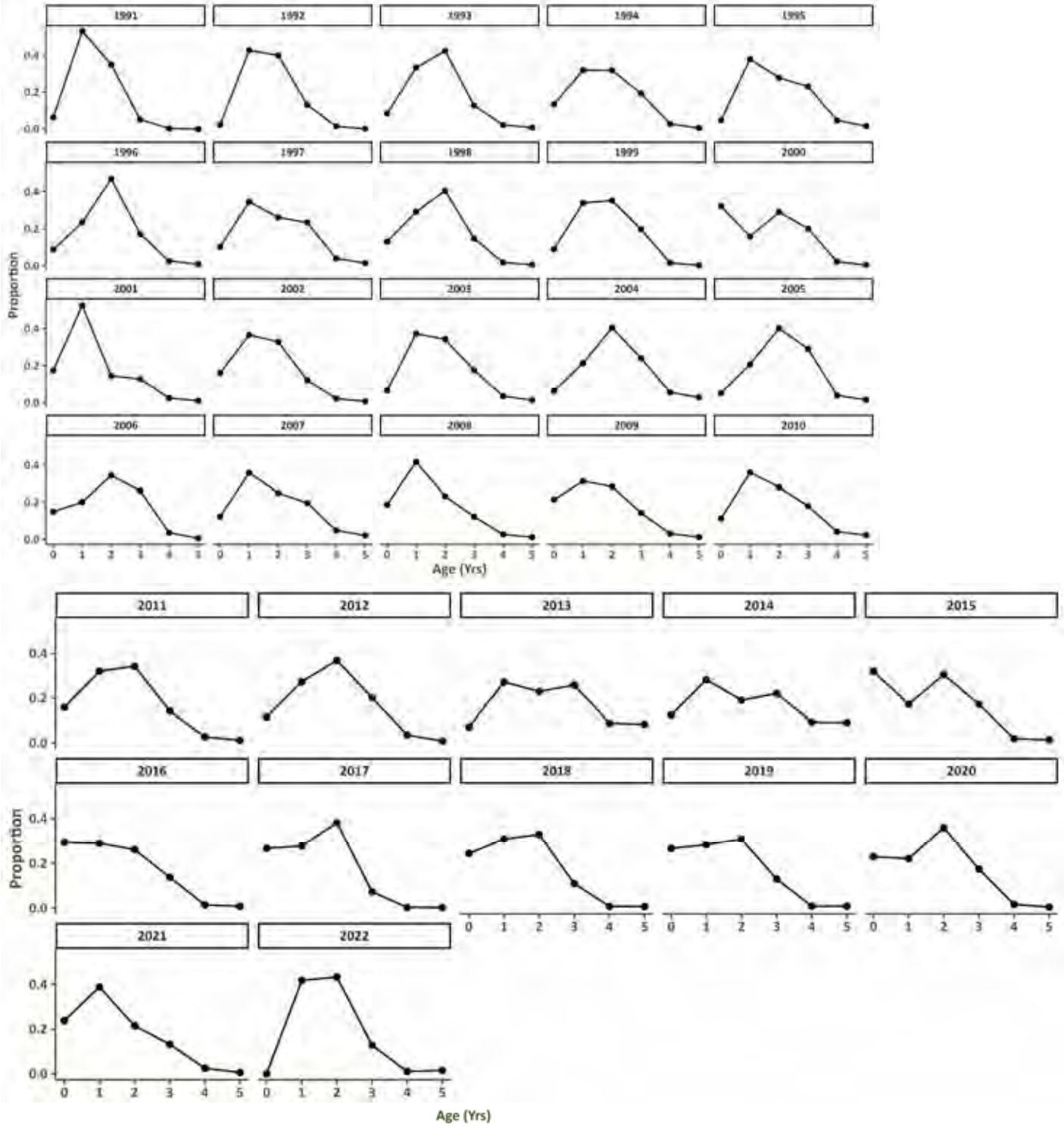
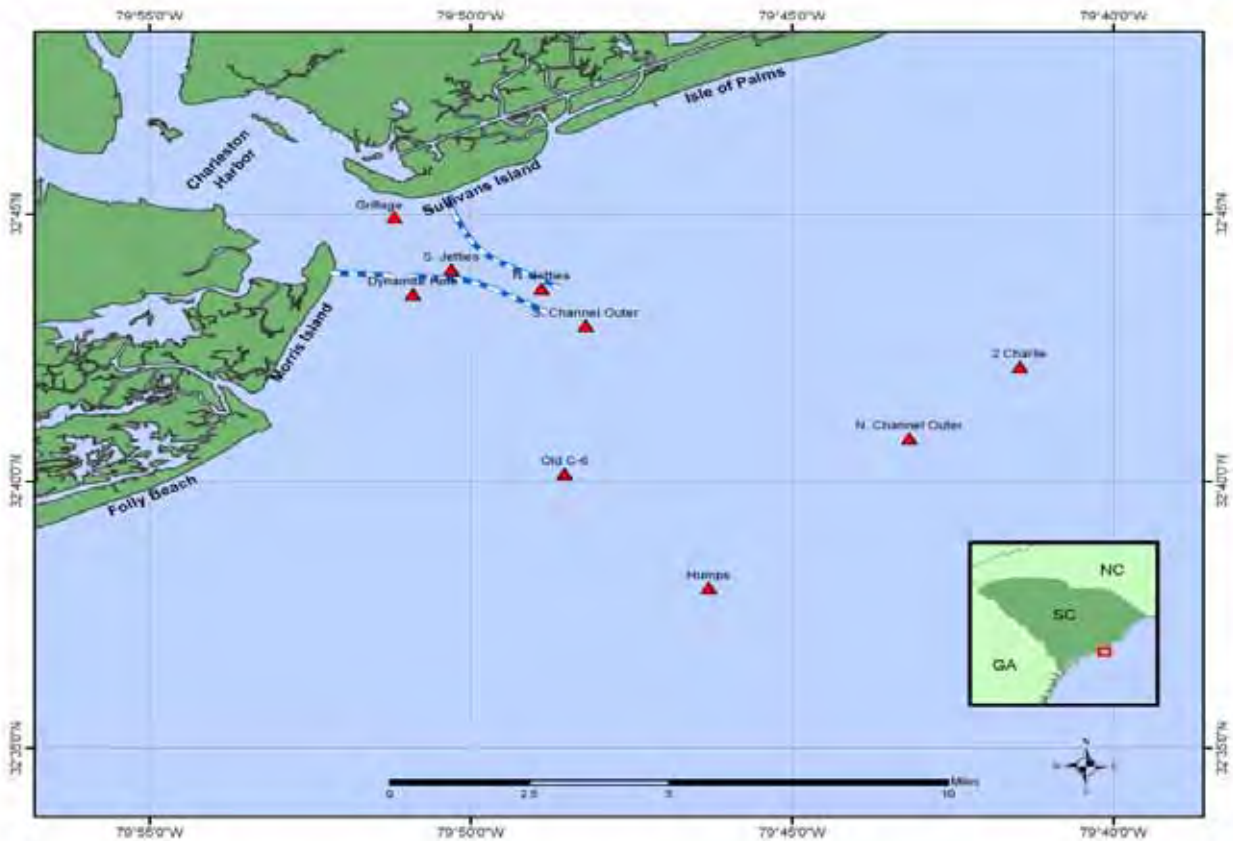


Figure 95. Annual length compositions developed for the South Carolina Trammel Net Survey (SC\_Trammel).



**Figure 96. Annual age compositions developed for the South Carolina Trammel Net Survey (SC\_Trammel). Note, age represents biological age assuming a September 1 birthday and age-5 represents a 'plus' group.**



**Figure 97. Fixed stations sampled as part of the South Carolina Historic Longline Survey (SC\_Longline\_historic) conducted by the SCDNR from 1994-2006 near Charleston, SC. The five fixed stations considered for index development are outlined by red circles.**



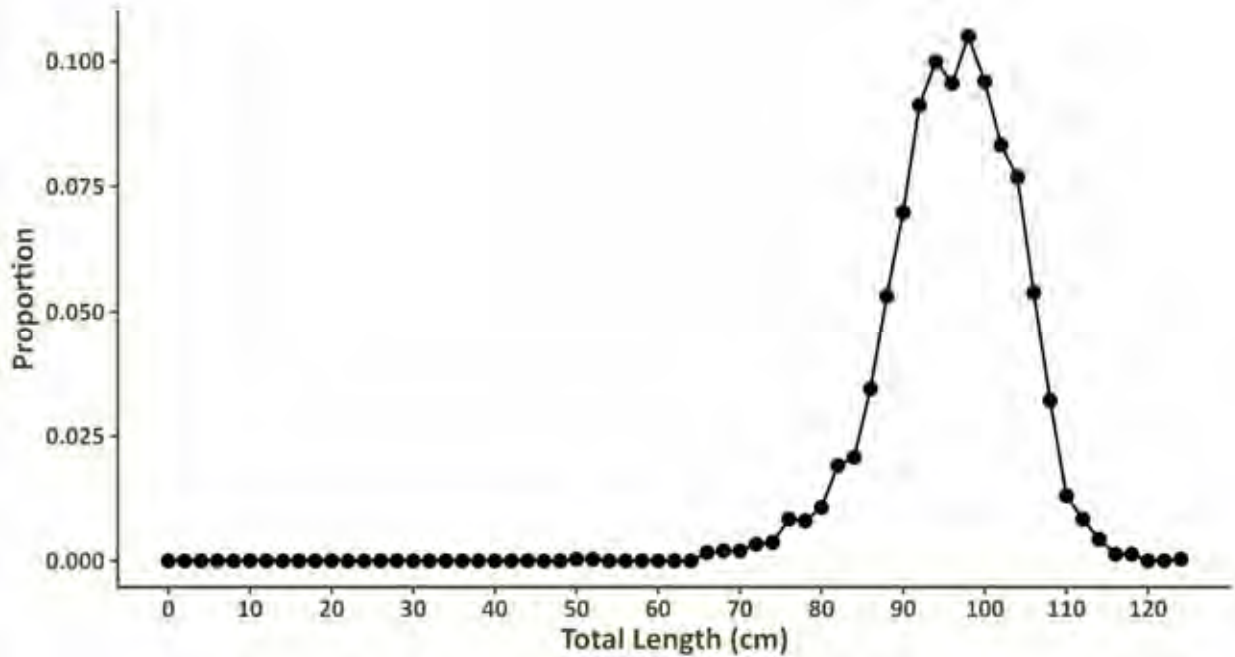


Figure 98. Length composition of red drum encountered by the South Carolina Historic Longline Survey (SC\_Longline\_historic) when pooled across all years.

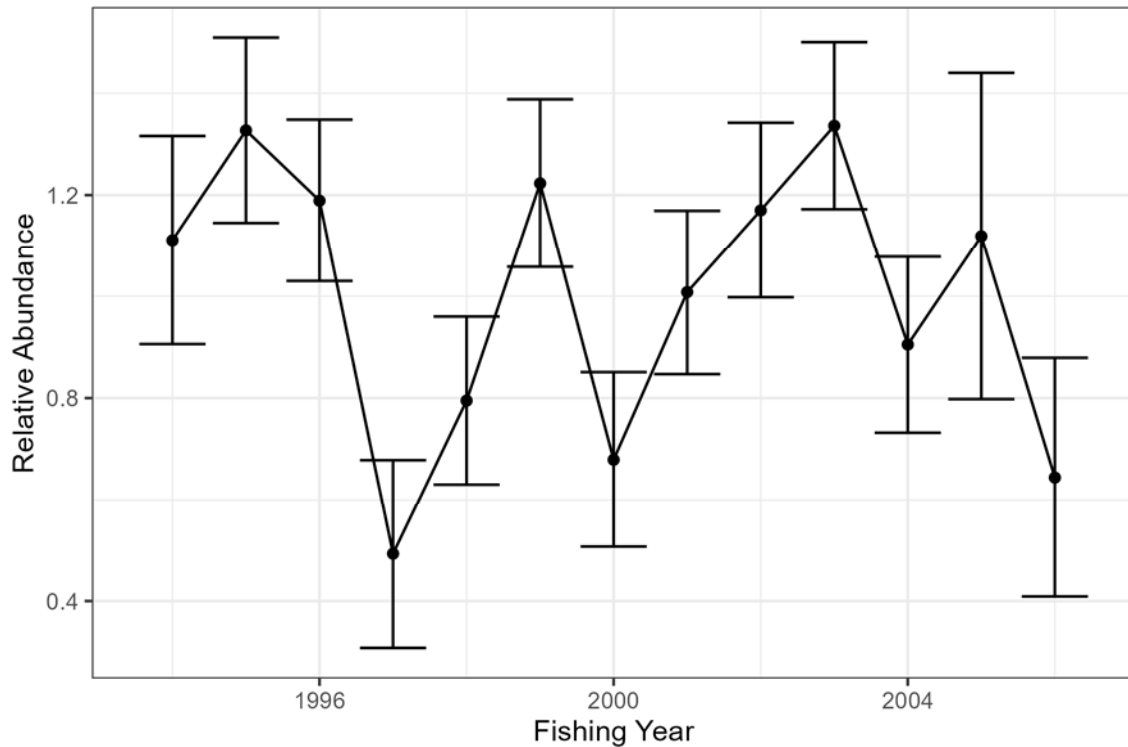


Figure 99. South Carolina Historic Longline Survey (SC\_Longline\_historic) relative abundance, standardized to its mean, from 1994-2006. Error bars are  $\pm$  one standard error.

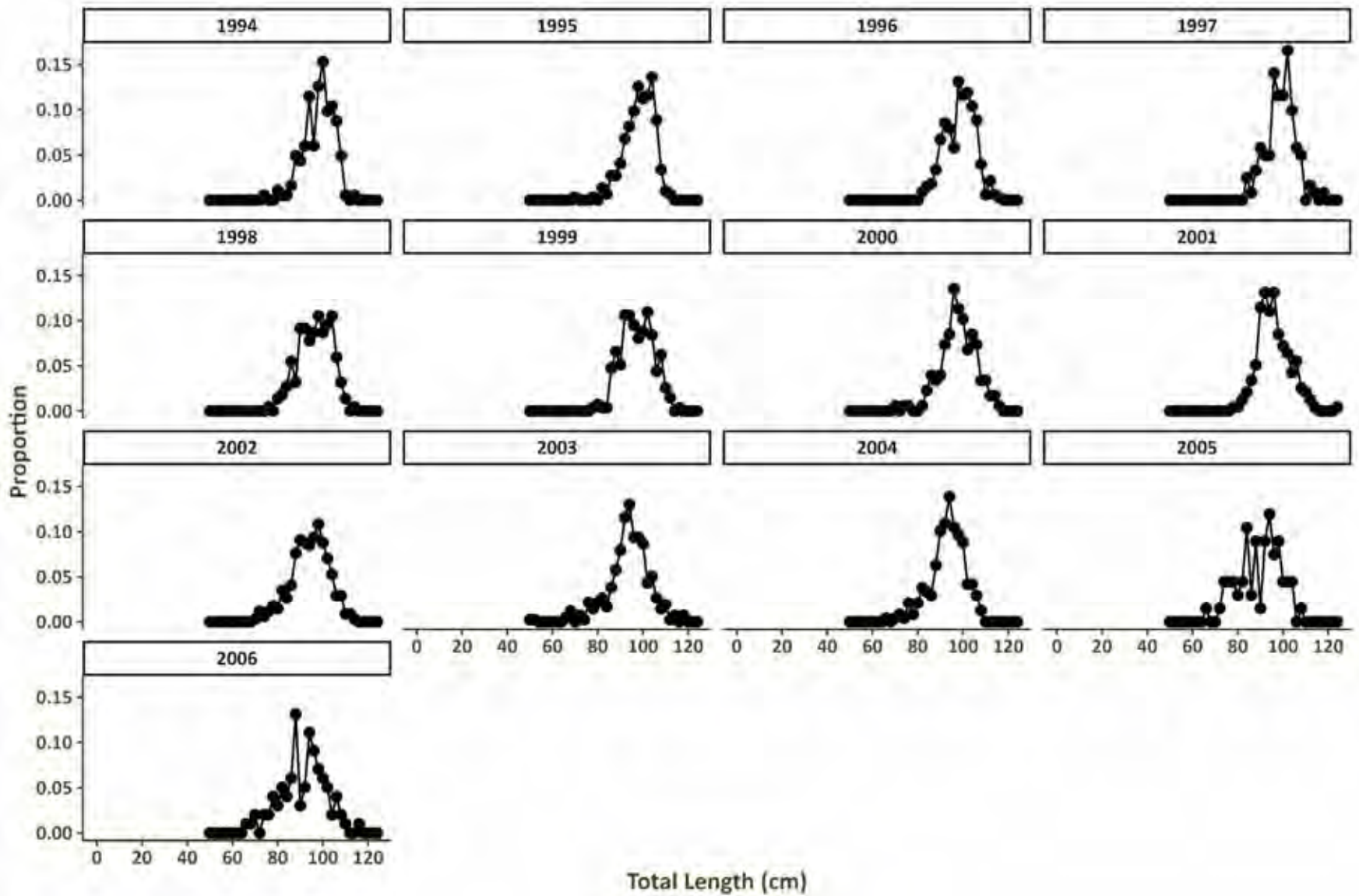


Figure 100. Annual length compositions developed for the South Carolina Historic Longline Survey (SC\_Longline\_historic)

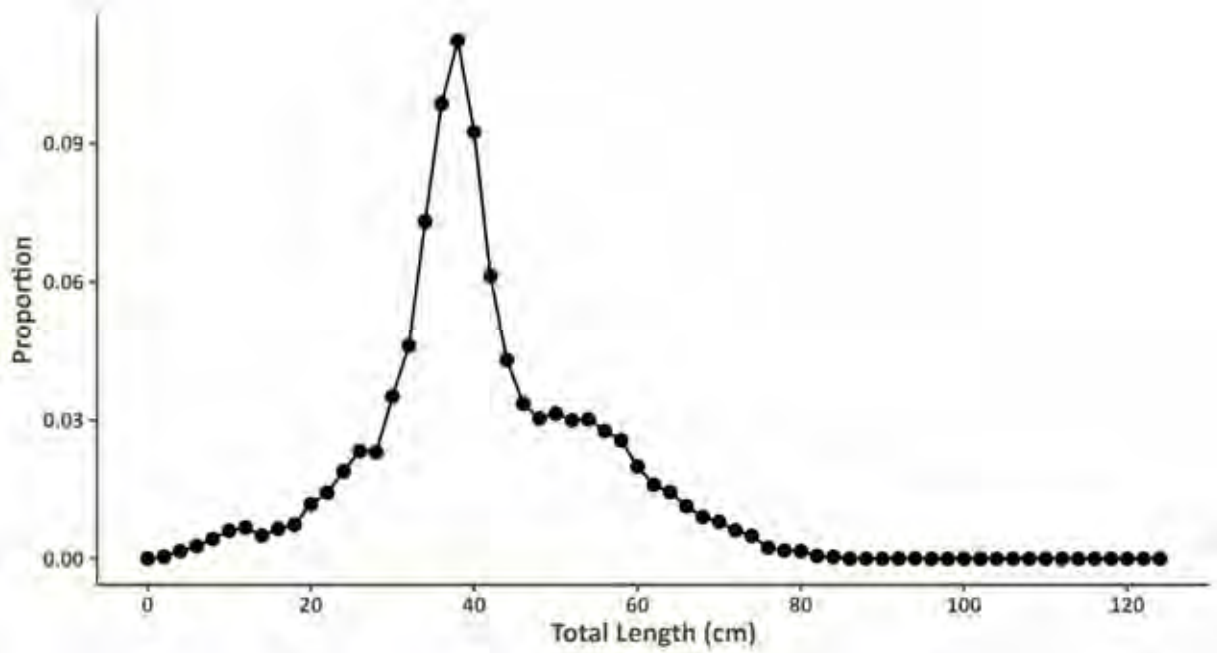


Figure 101. Length composition of red drum encountered by the South Carolina Electrofishing Survey (SC\_Electro) when pooled across all years.

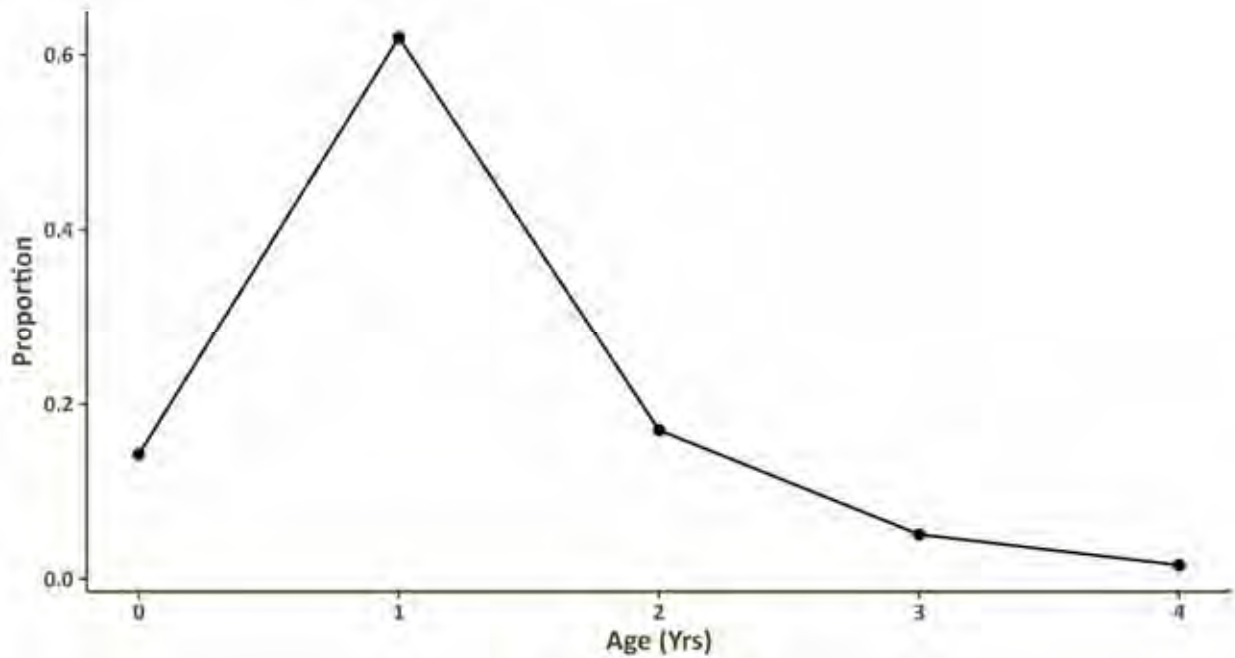
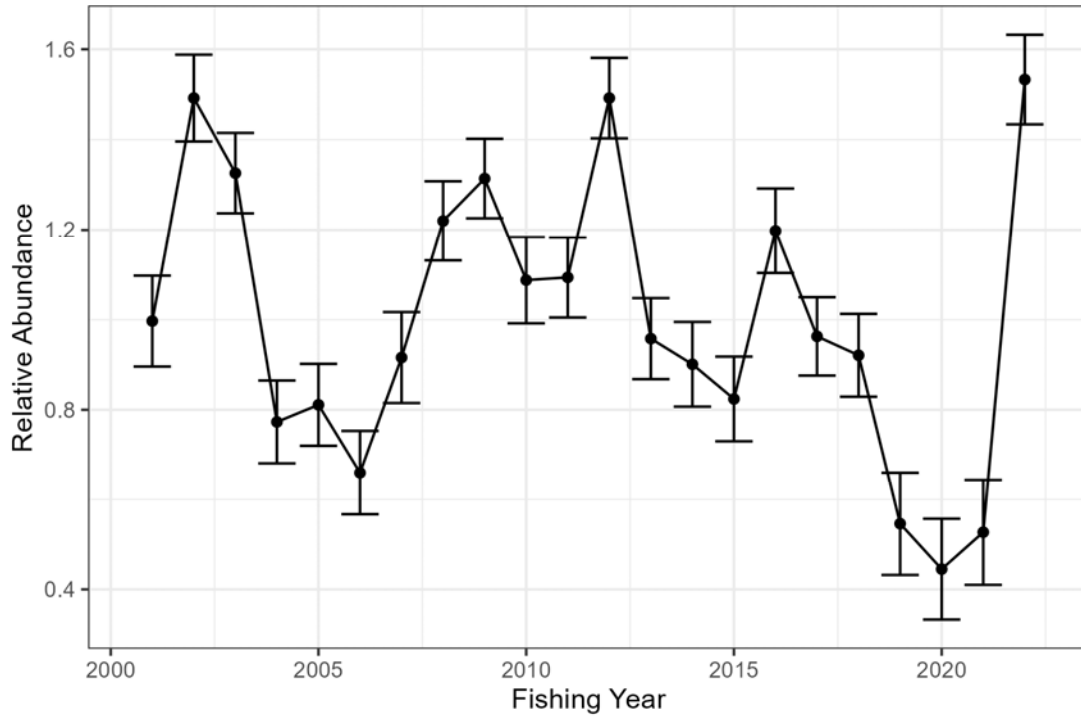
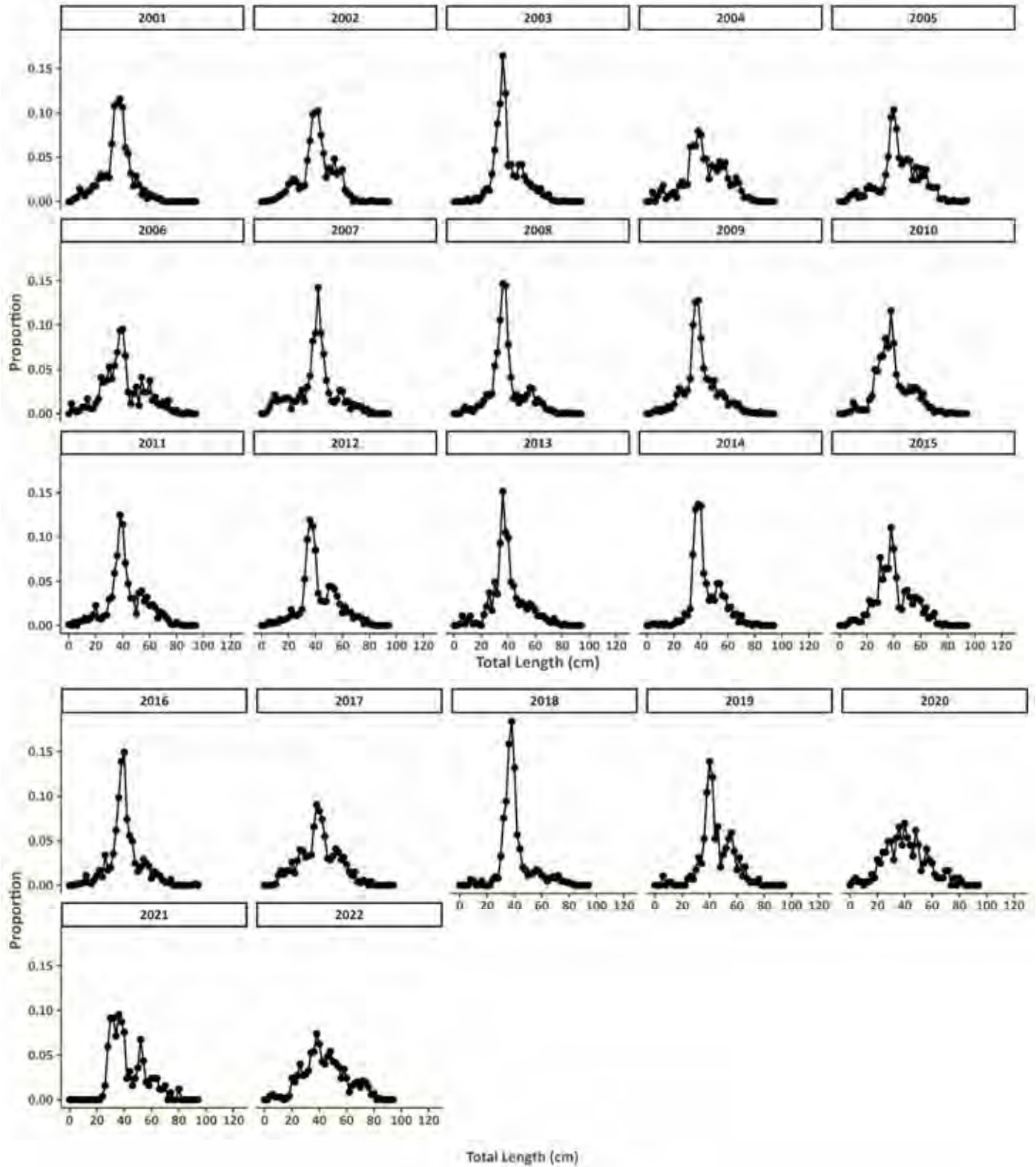


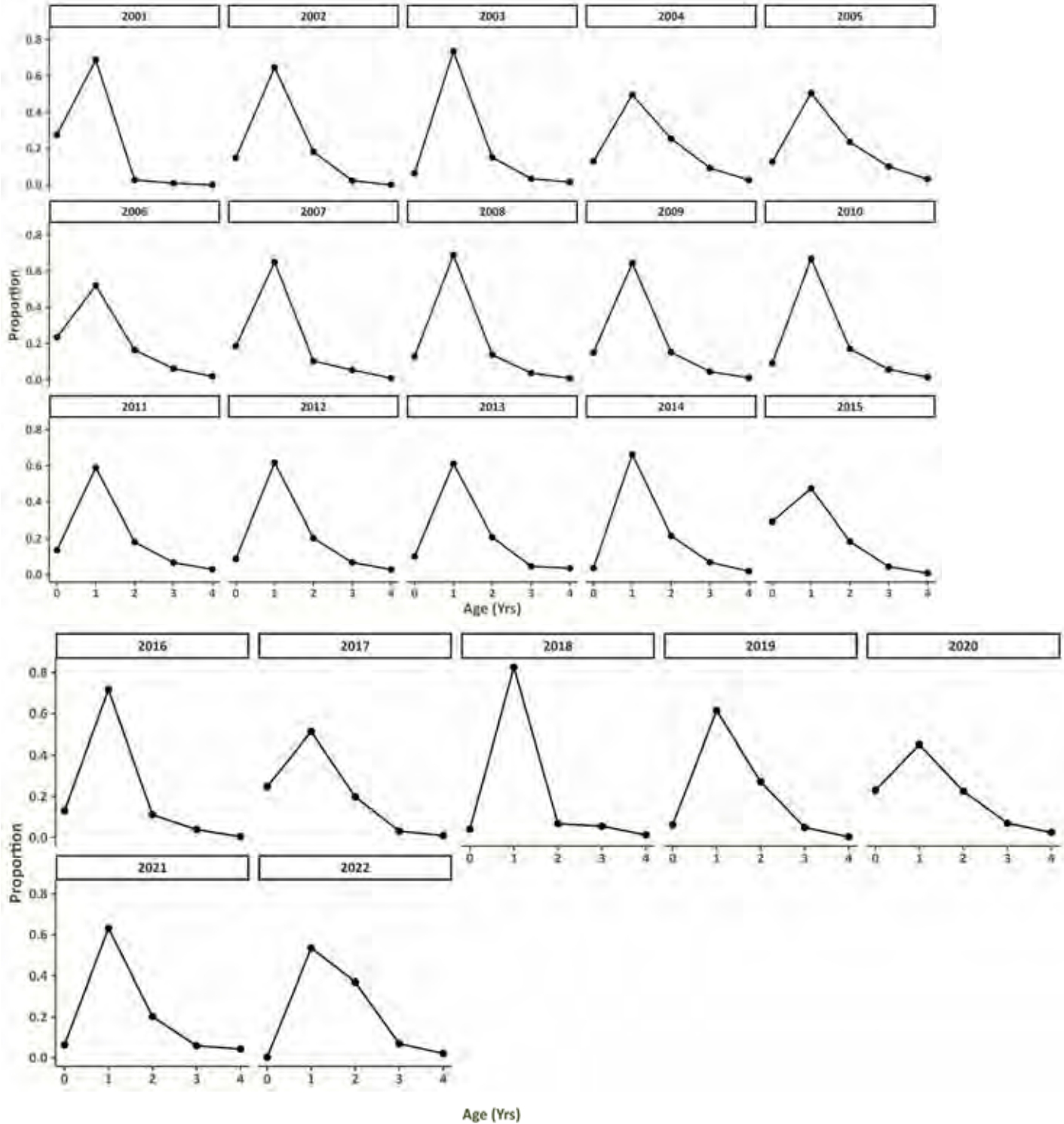
Figure 102. Age composition of red drum encountered by the South Carolina Electrofishing Survey (SC\_Electro) when pooled across all years. Age 4 represents an age 4+ group.



**Figure 103. South Carolina Electrofishing Survey (SC\_Electro) relative abundance, standardized to its mean, from 2001-2022. Error bars are  $\pm$  one standard error.**



**Figure 104. Annual length compositions developed for the South Carolina Electrofishing Survey (SC\_Electro).**



**Figure 105.** Annual age compositions developed for the South Carolina Electrofishing Survey (SC\_Electro). Note, age represents biological age assuming a September 1 birthday and age-4 represents a 'plus' group.

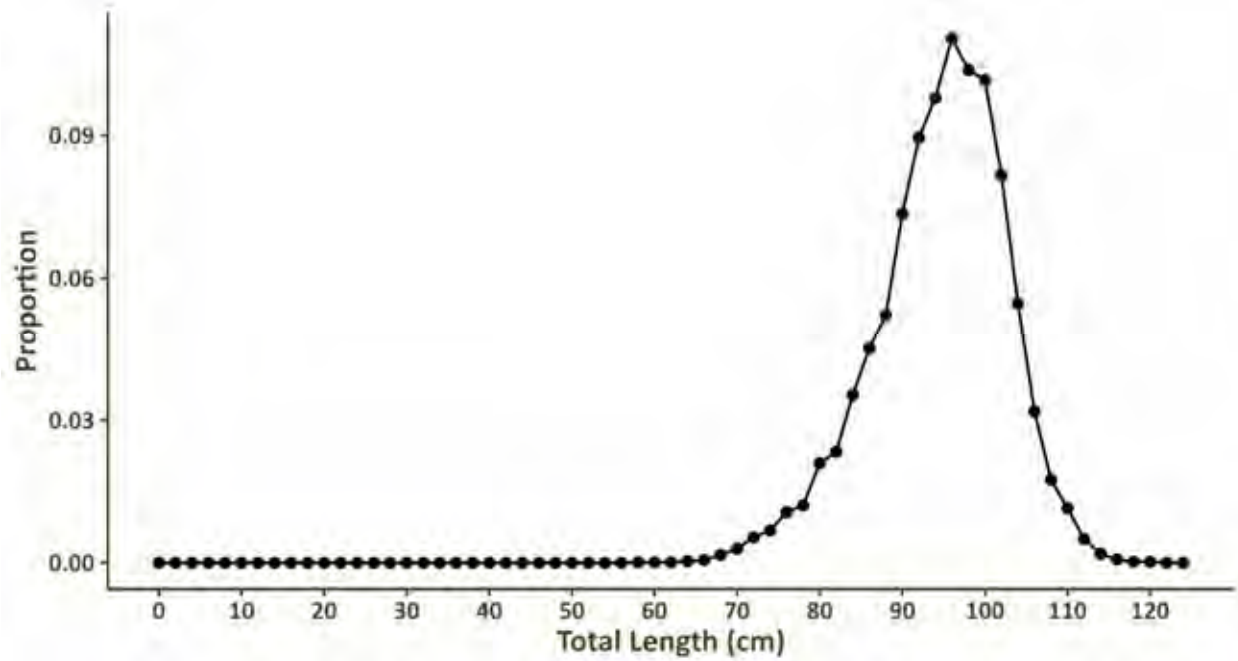


Figure 106. Length composition of red drum encountered by the South Carolina Contemporary Longline Survey (SC\_Longline\_contemporary) when pooled across all years.

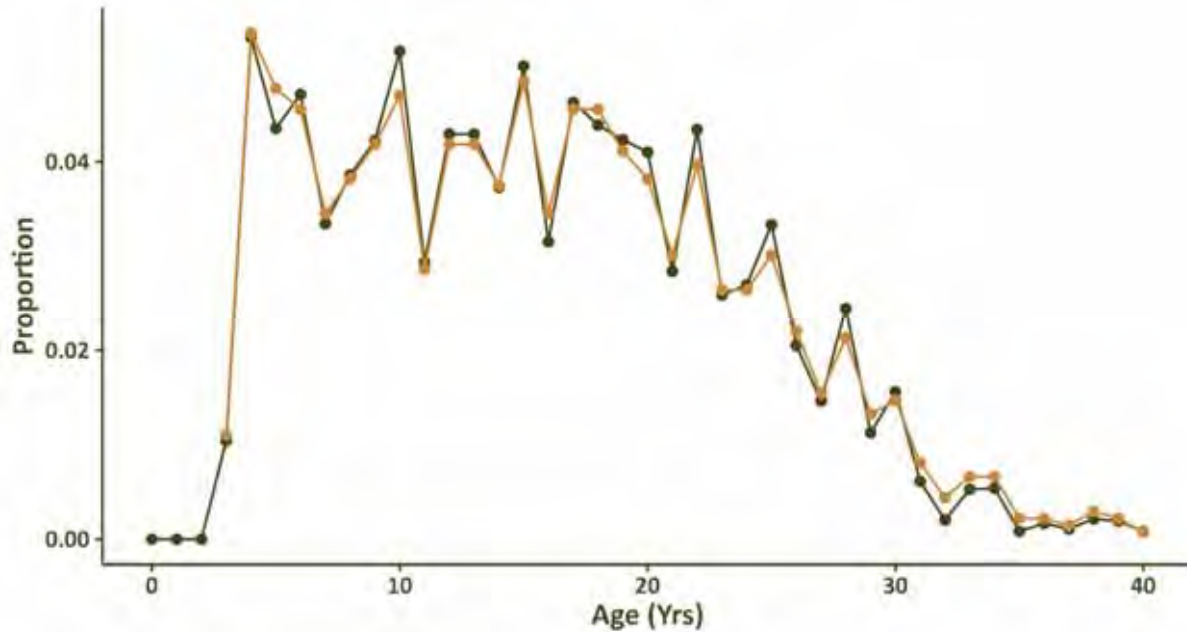


Figure 107. Age composition of red drum encountered by the South Carolina Contemporary Longline Survey (SC\_Longline\_contemporary) when pooled across all years using either raw, randomly selected aged fish (orange) and the best fit proportional odds logistic regression model (green).

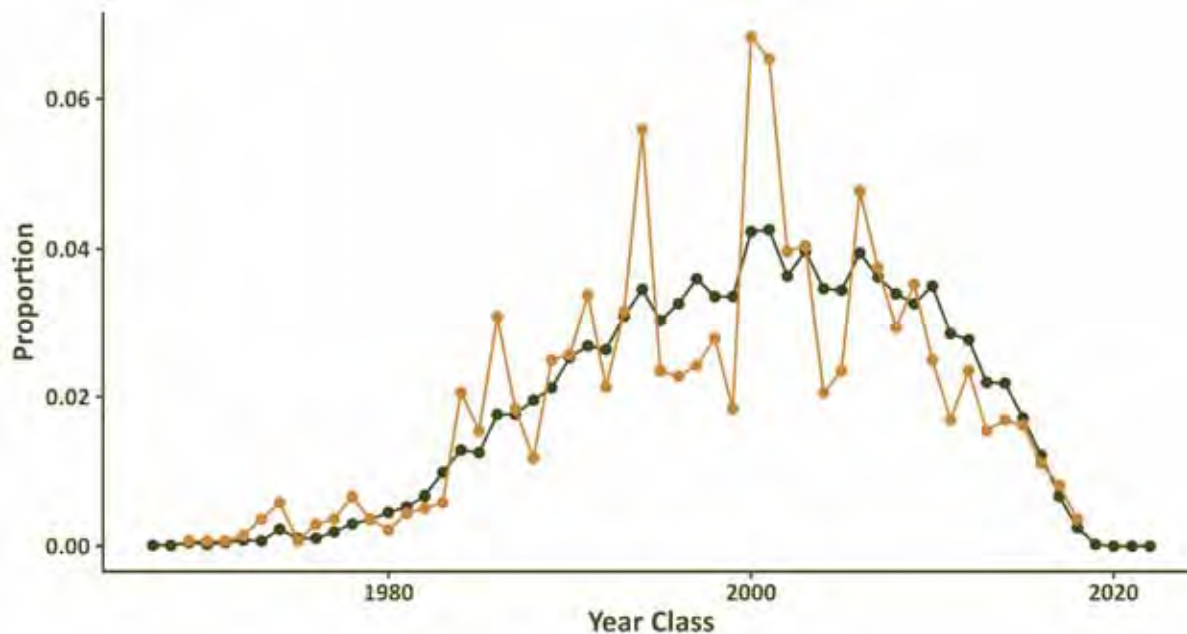
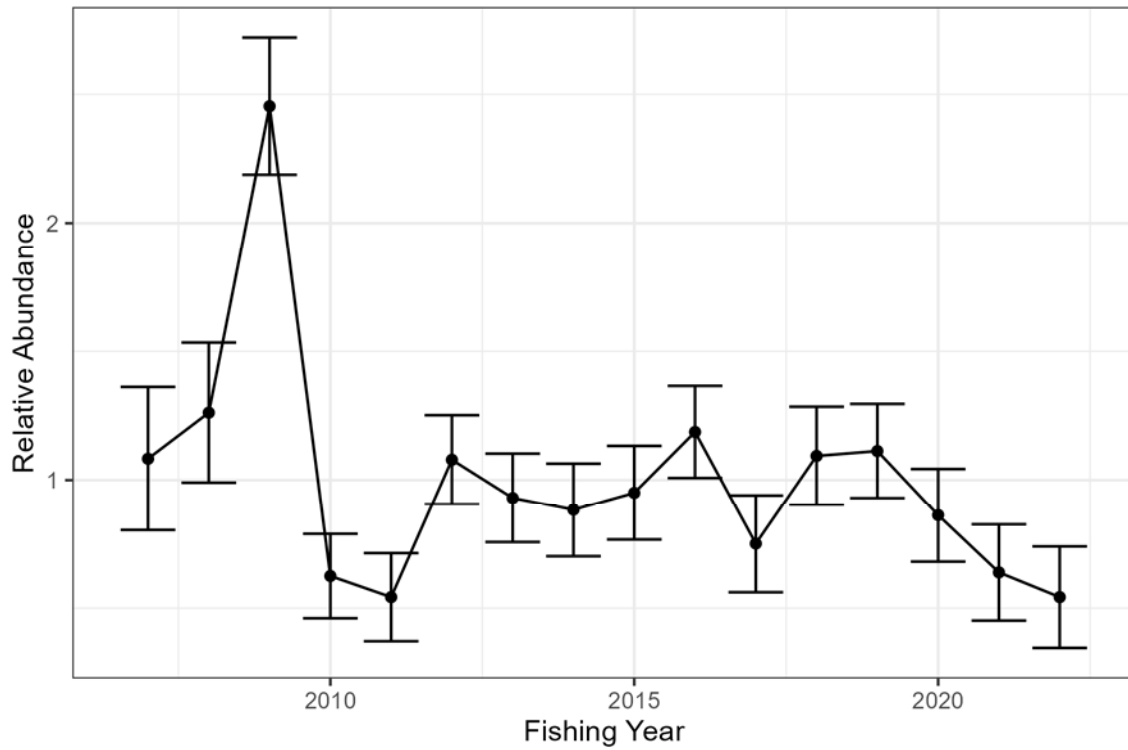


Figure 108. Year class composition of red drum encountered by the South Carolina Contemporary Longline Survey (SC\_Longline\_contemporary) when pooled across all years using either raw, randomly selected aged fish (orange) and the best fit proportional odds logistic regression model (green).





**Figure 109. SCDNR South Carolina Contemporary Longline Survey (SC\_Longline\_contemporary) relative abundance, standardized to its mean, from 2007-2022. Error bars are  $\pm$  one standard error.**

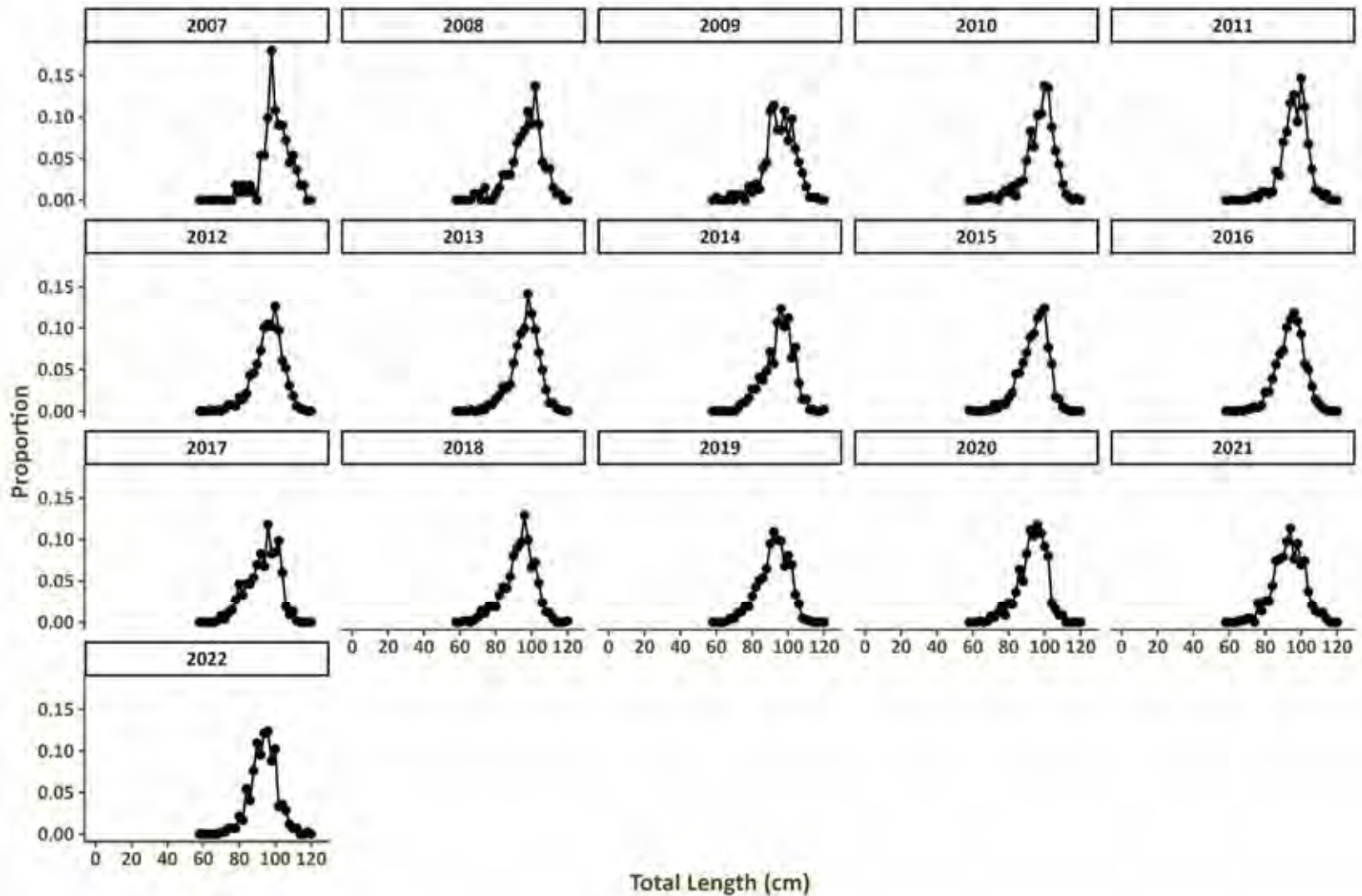


Figure 110. Annual length compositions developed for the South Carolina Contemporary Longline Survey (SC\_Longline\_contemporary).

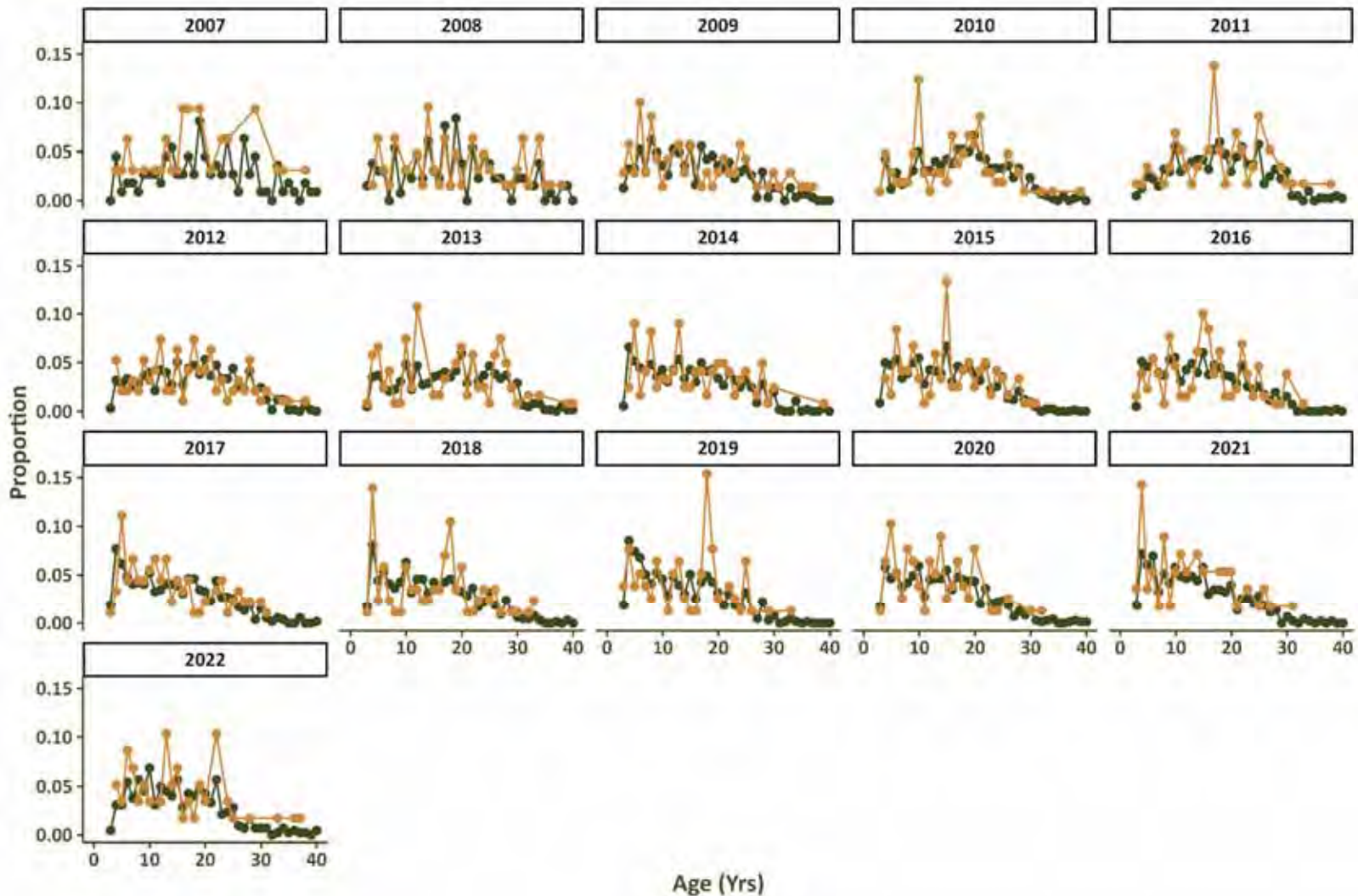
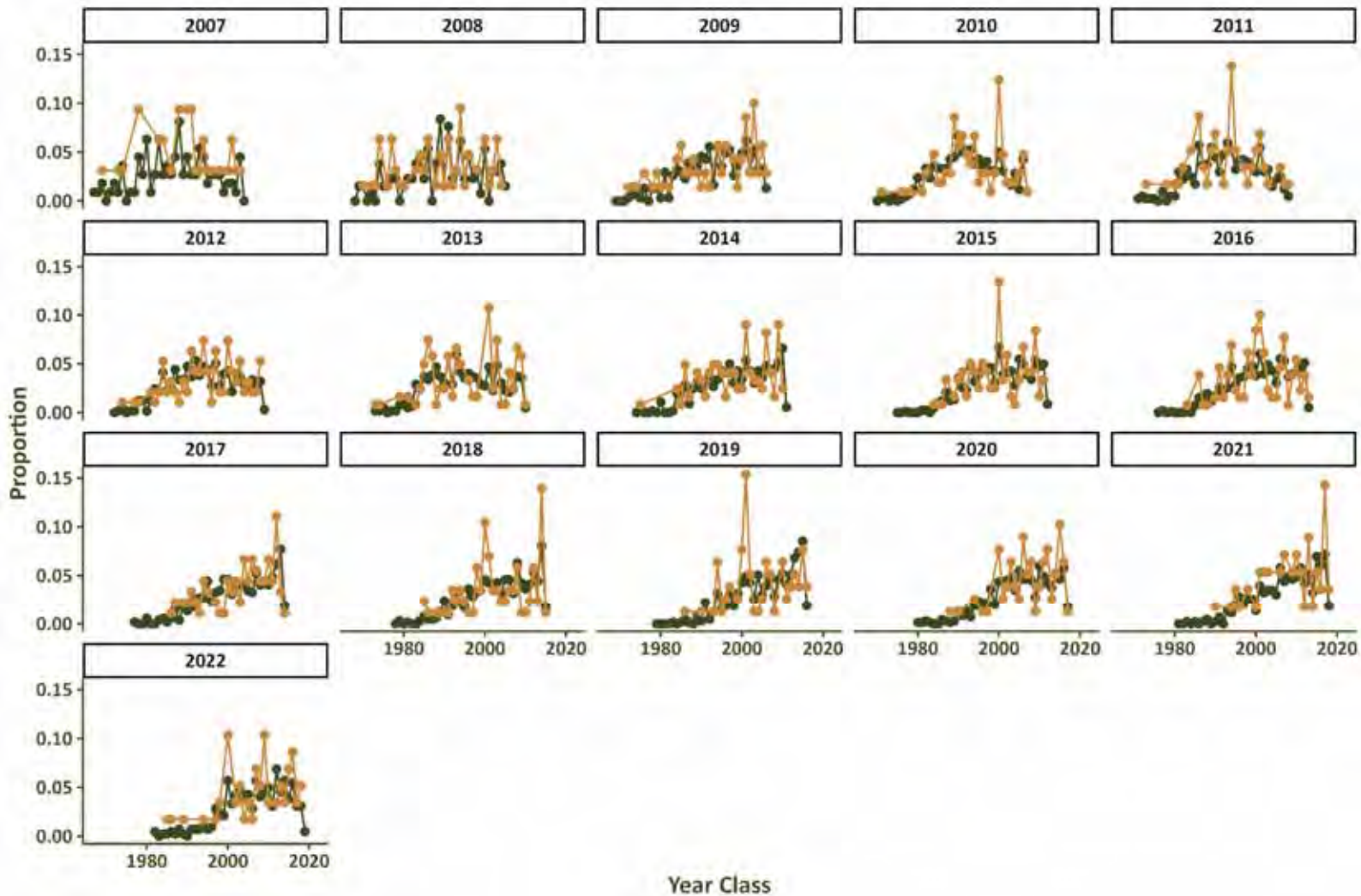


Figure 111. Annual age compositions developed for the South Carolina Contemporary Longline Survey (SC\_Longline\_contemporary) using either raw, randomly selected aged fish (orange) and the best fit proportional odds logistic regression model (green).



**Figure 112.** Annual year class compositions developed for the South Carolina Contemporary Longline Survey (SC\_Longline\_contemporary) using either raw, randomly selected aged fish (orange) and the best fit proportional odds logistic regression model (green).



**Figure 113. Coastal Georgia counties with approximate Wassaw Sound and Altamaha River system sample areas.**

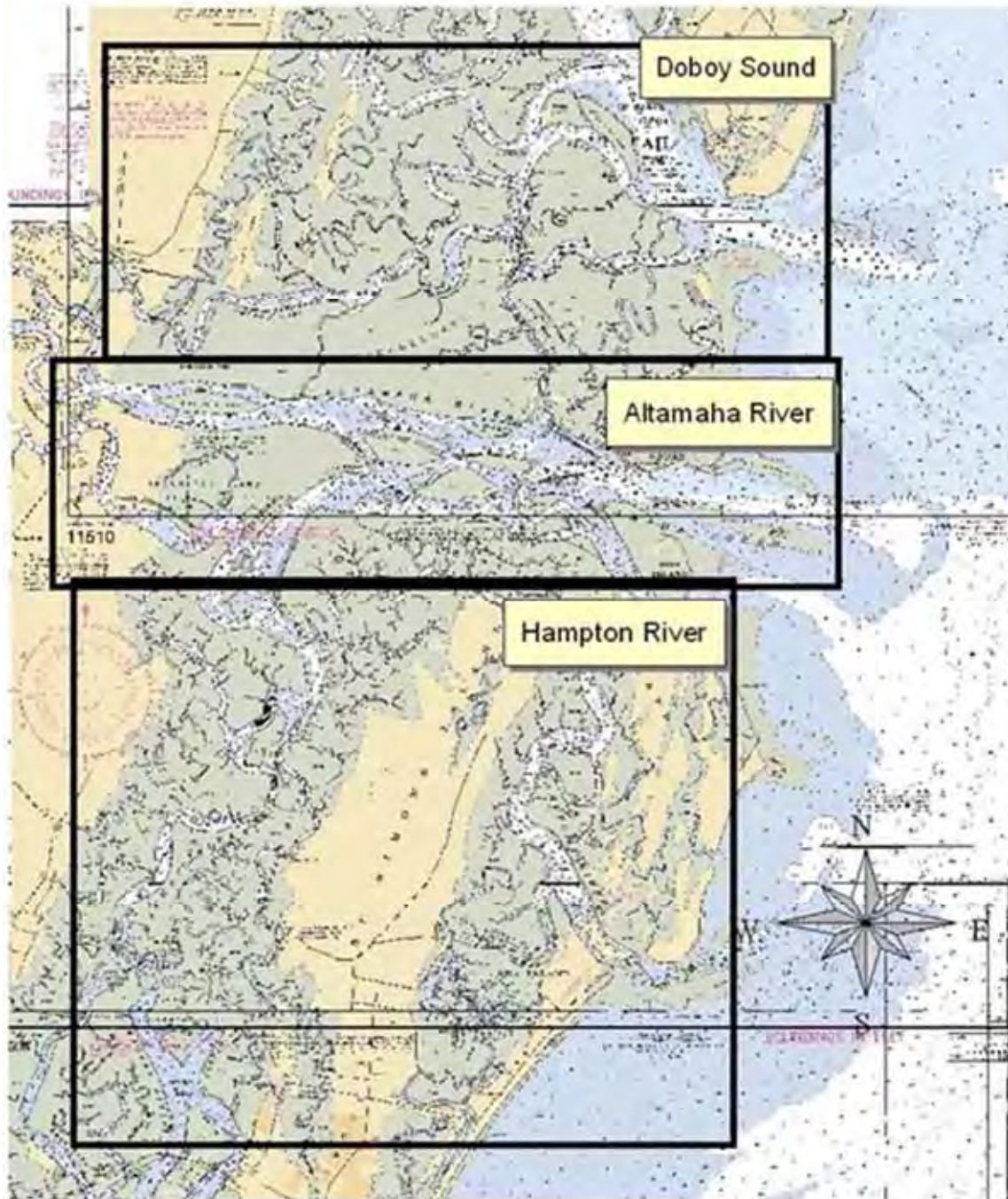


Figure 114. Sample areas for Altamaha River System.

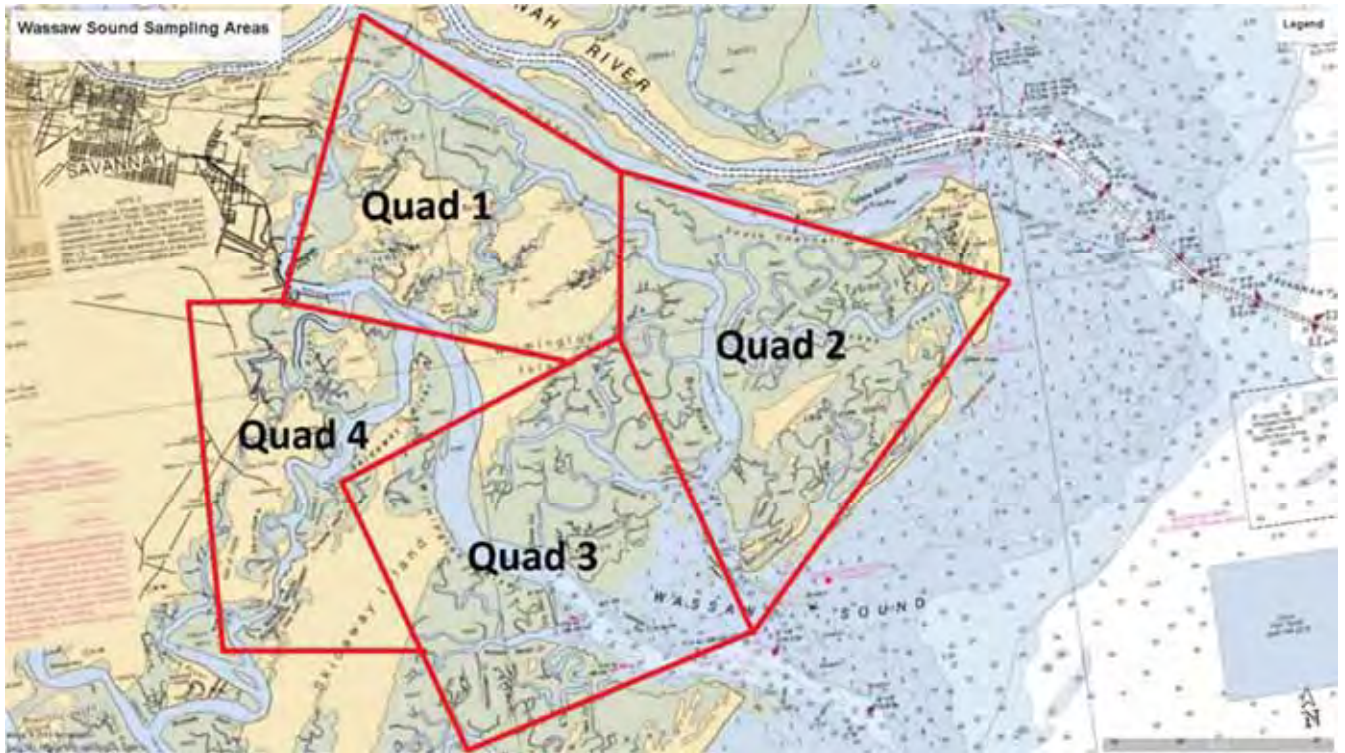


Figure 115. Sample areas for Wassaw Sound.

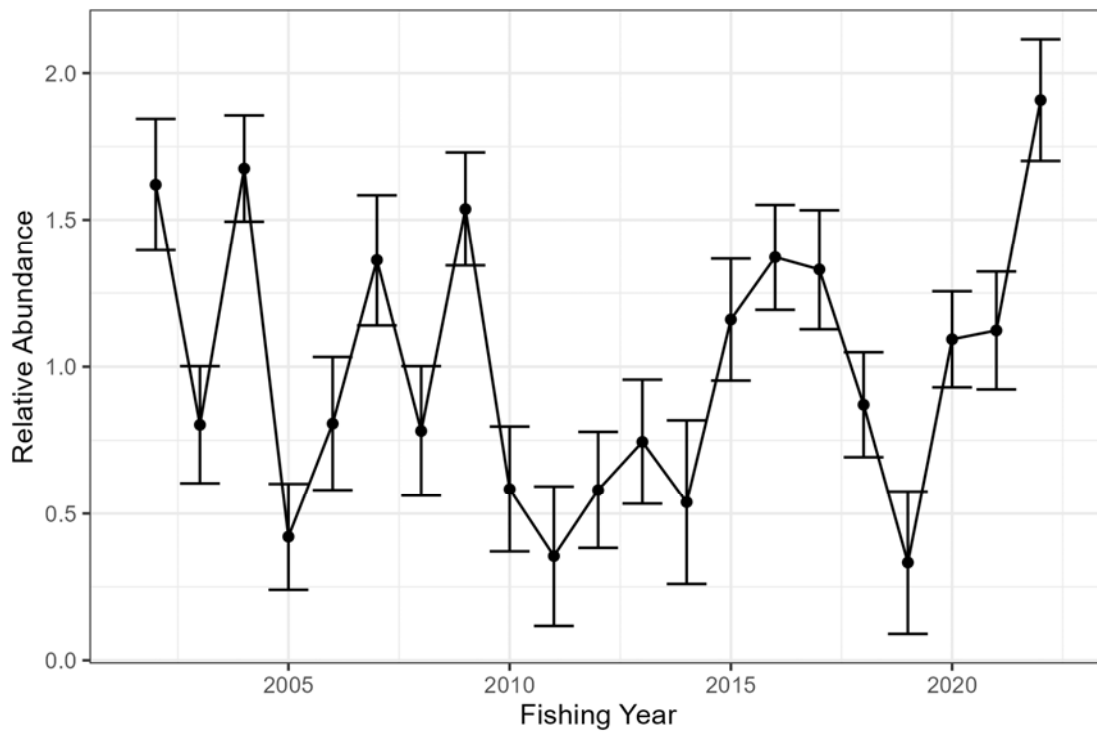
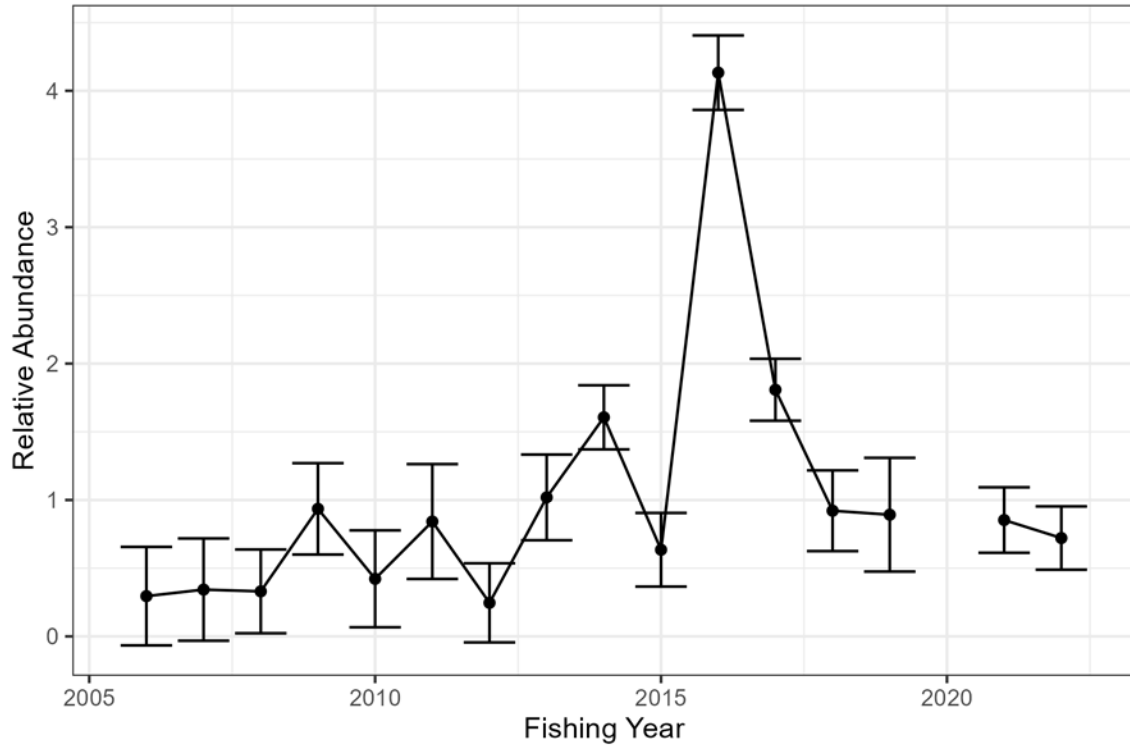
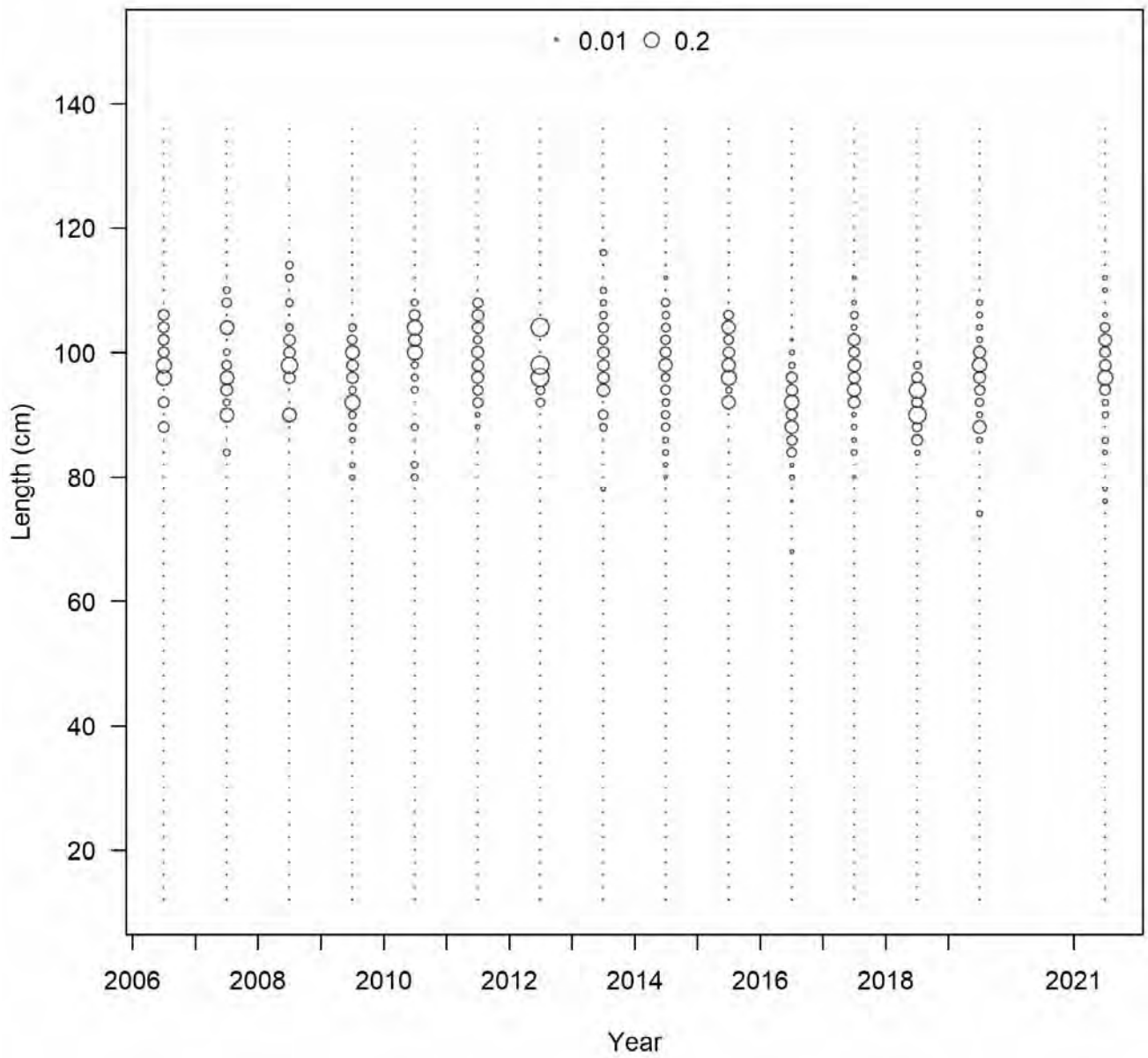


Figure 116. Georgia Gill Net Survey (GA\_GillNet) relative abundance, standardized to its mean, from 2002-2022. Error bars are  $\pm$  one standard error.

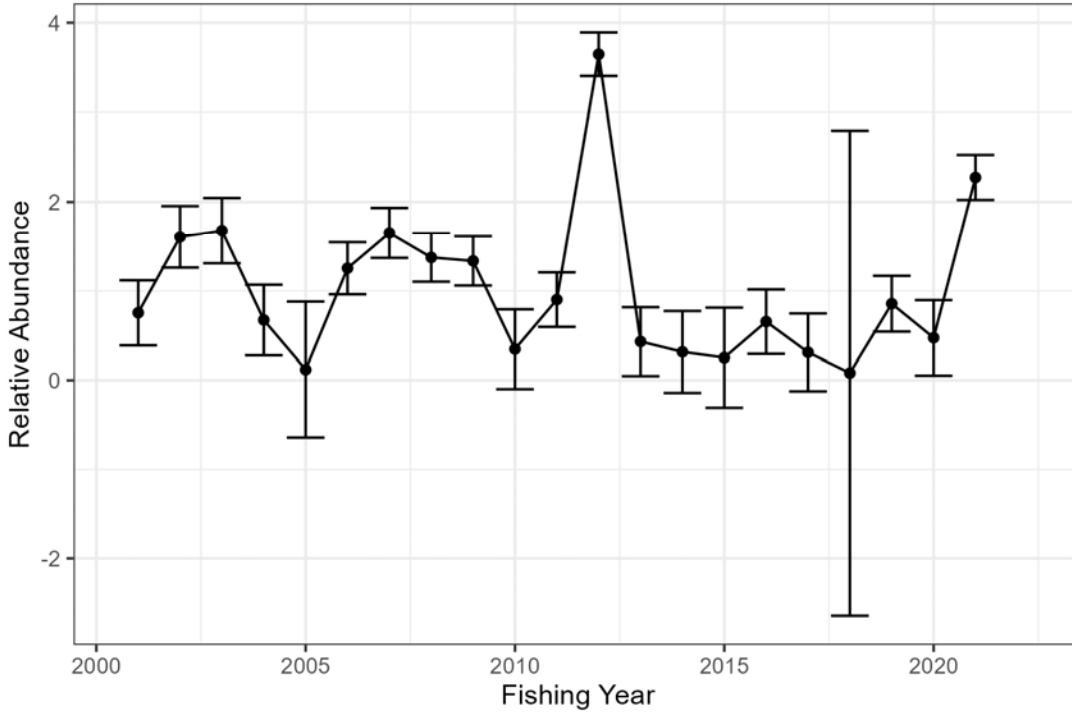


**Figure 117. Georgia Longline Survey (GA\_Longline) relative abundance, standardized to its mean, from 2006-2022. Error bars are  $\pm$  one standard error.**

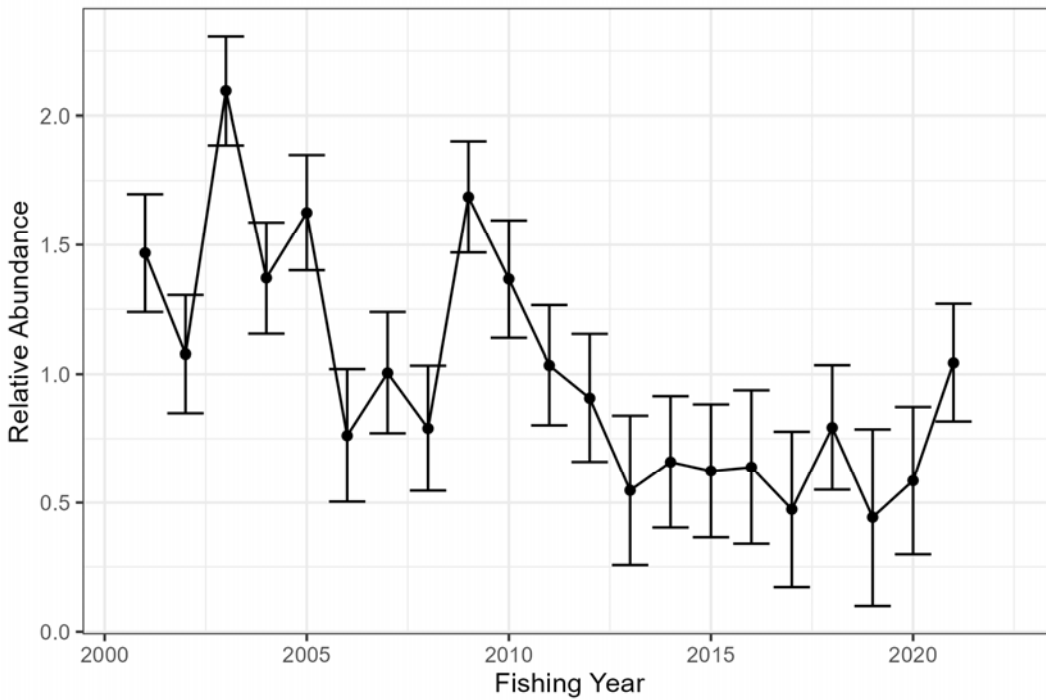




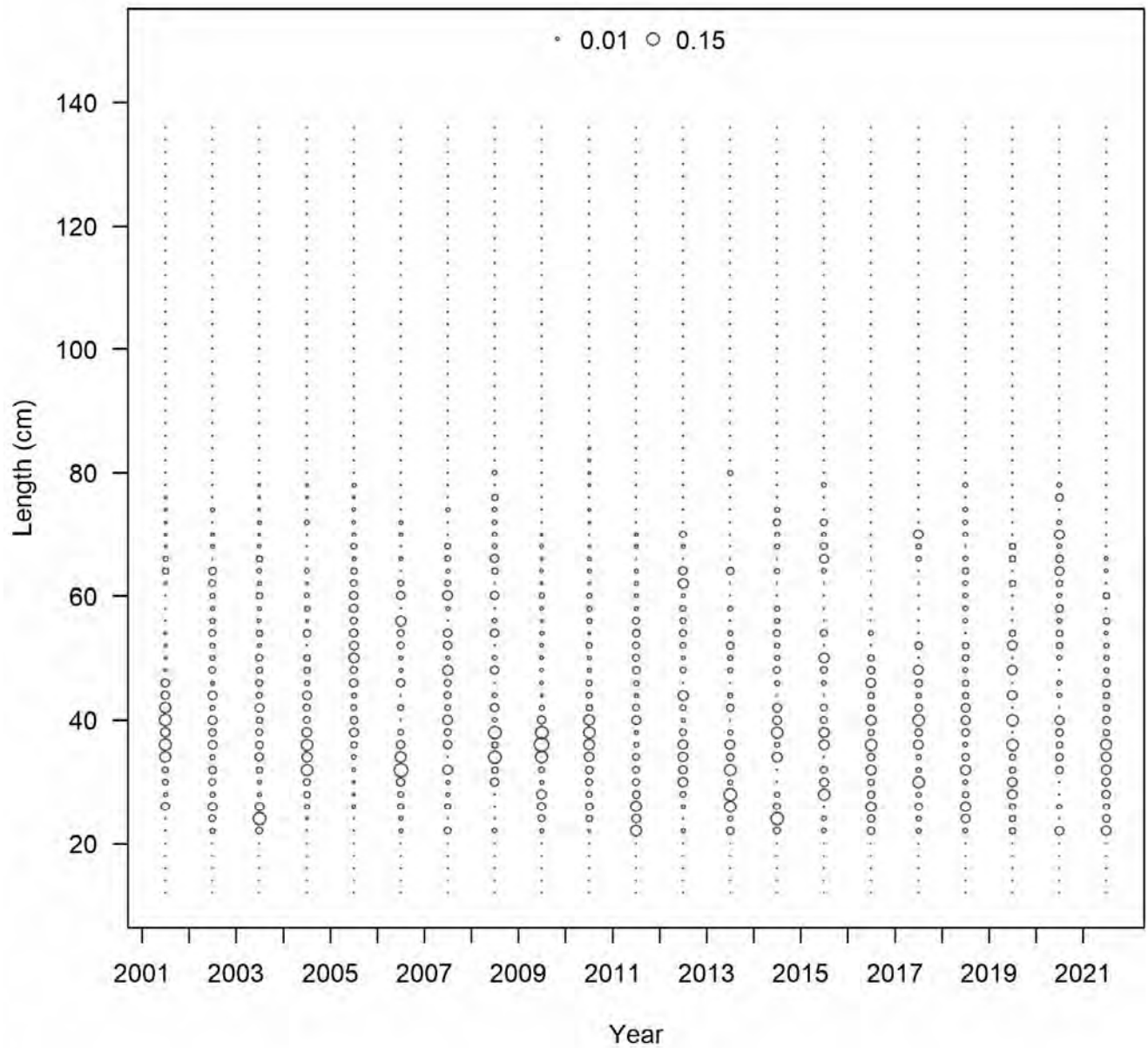
**Figure 118. Length compositions of red drum captured during the Georgia longline survey (GA\_Longline).**



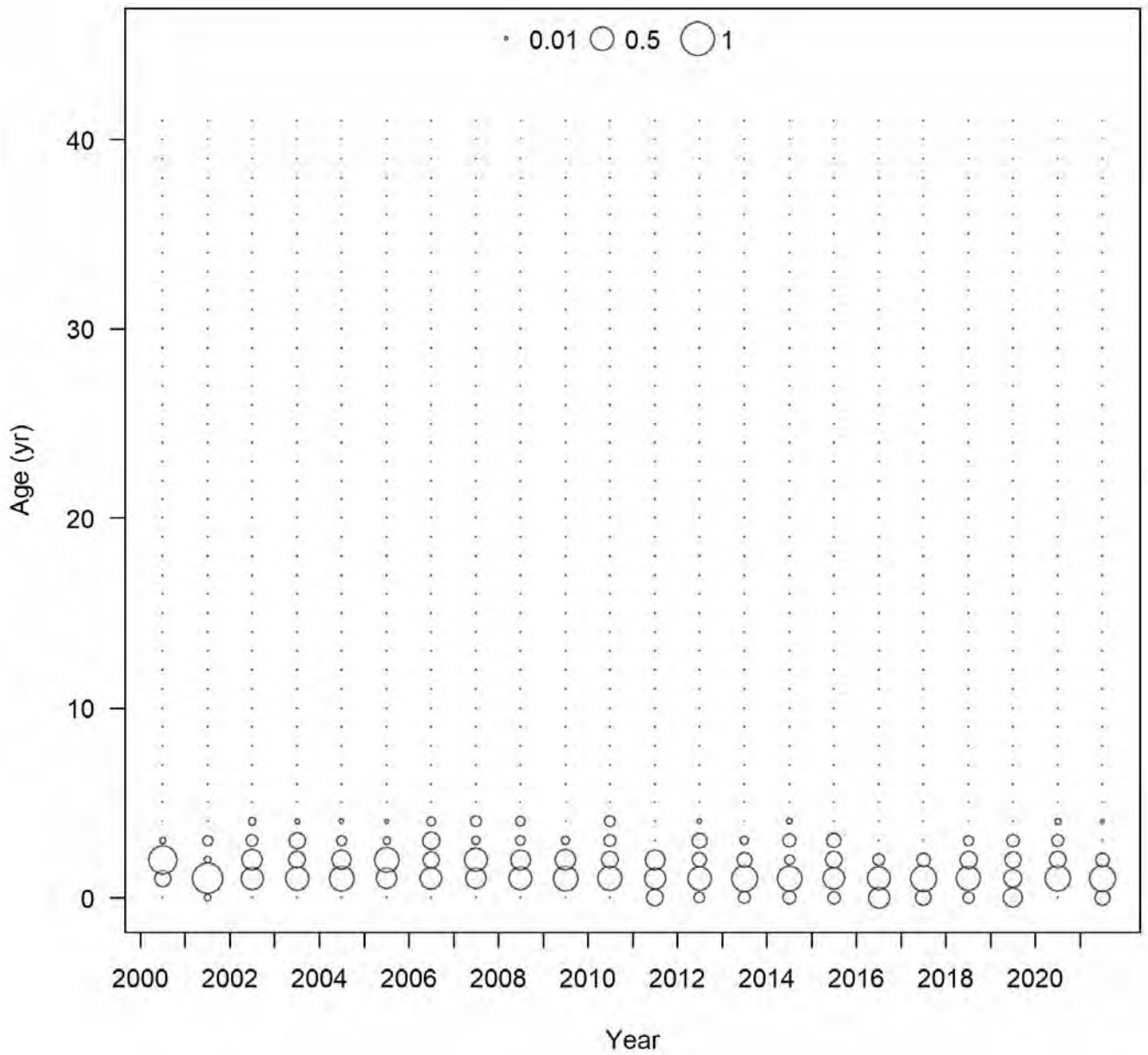
**Figure 119.** Florida 21.3 Meter Haul Seine Survey (FL\_21.3\_HaulSeine) relative abundance, standardized to its mean, from 2001-2021. Error bars are  $\pm$  one standard error.



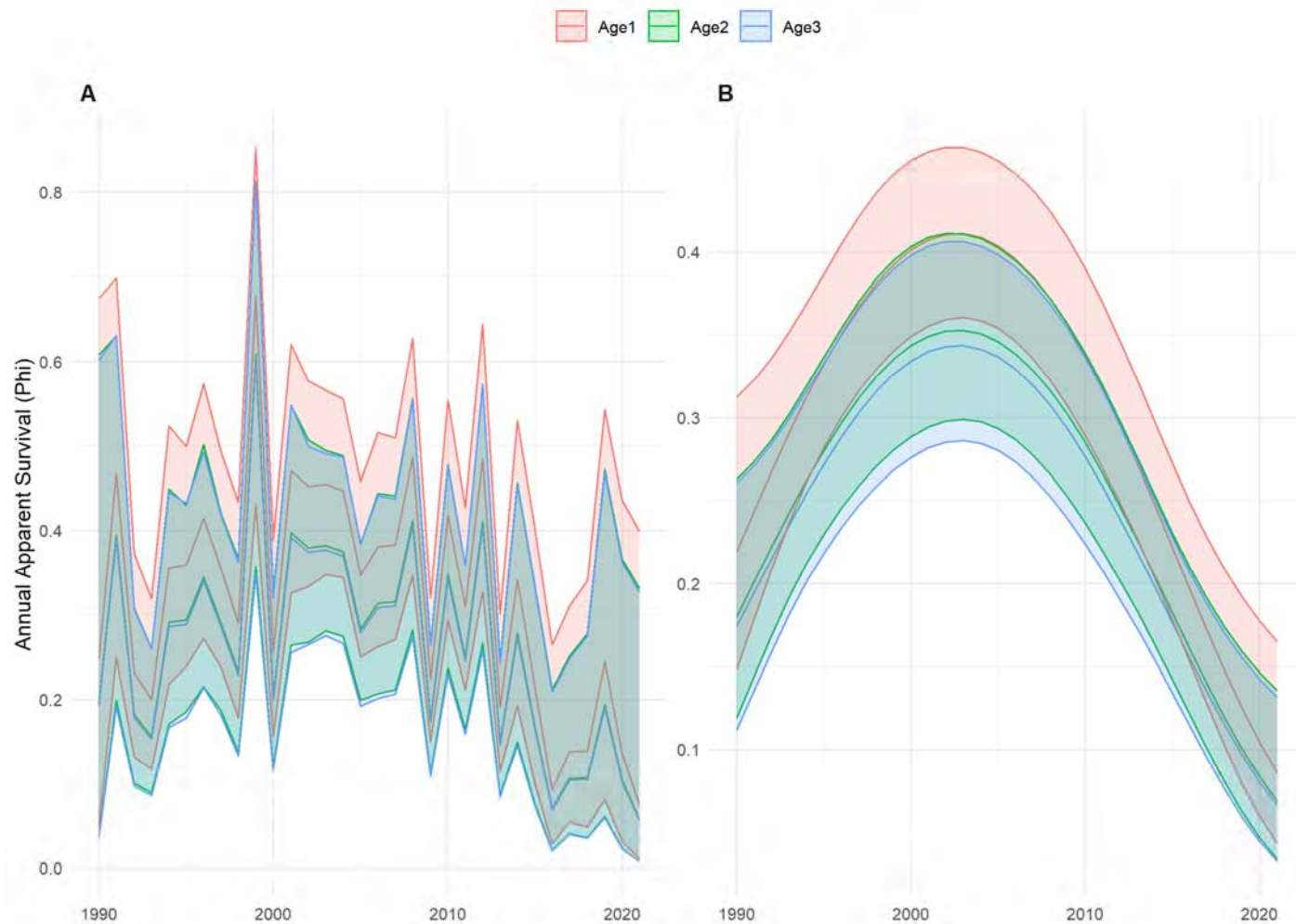
**Figure 120.** Florida 183 Meter Haul Seine Survey (FL\_183\_HaulSeine) relative abundance, standardized to its mean, from 2001-2021. Error bars are  $\pm$  one standard error.



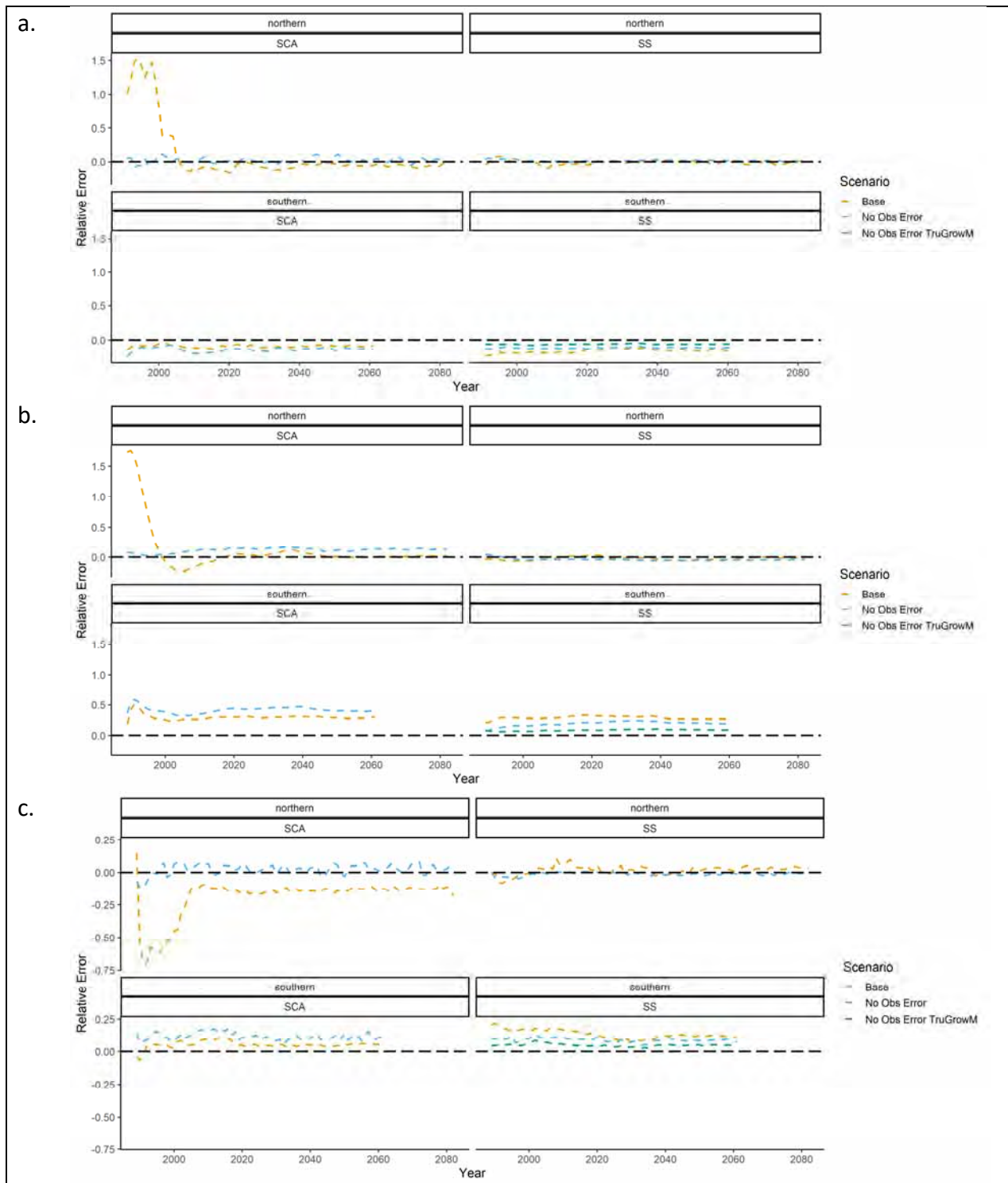
**Figure 121. Length compositions of red drum captured during the Florida 183 Meter Haul Seine Survey (FL\_183\_HaulSeine).**



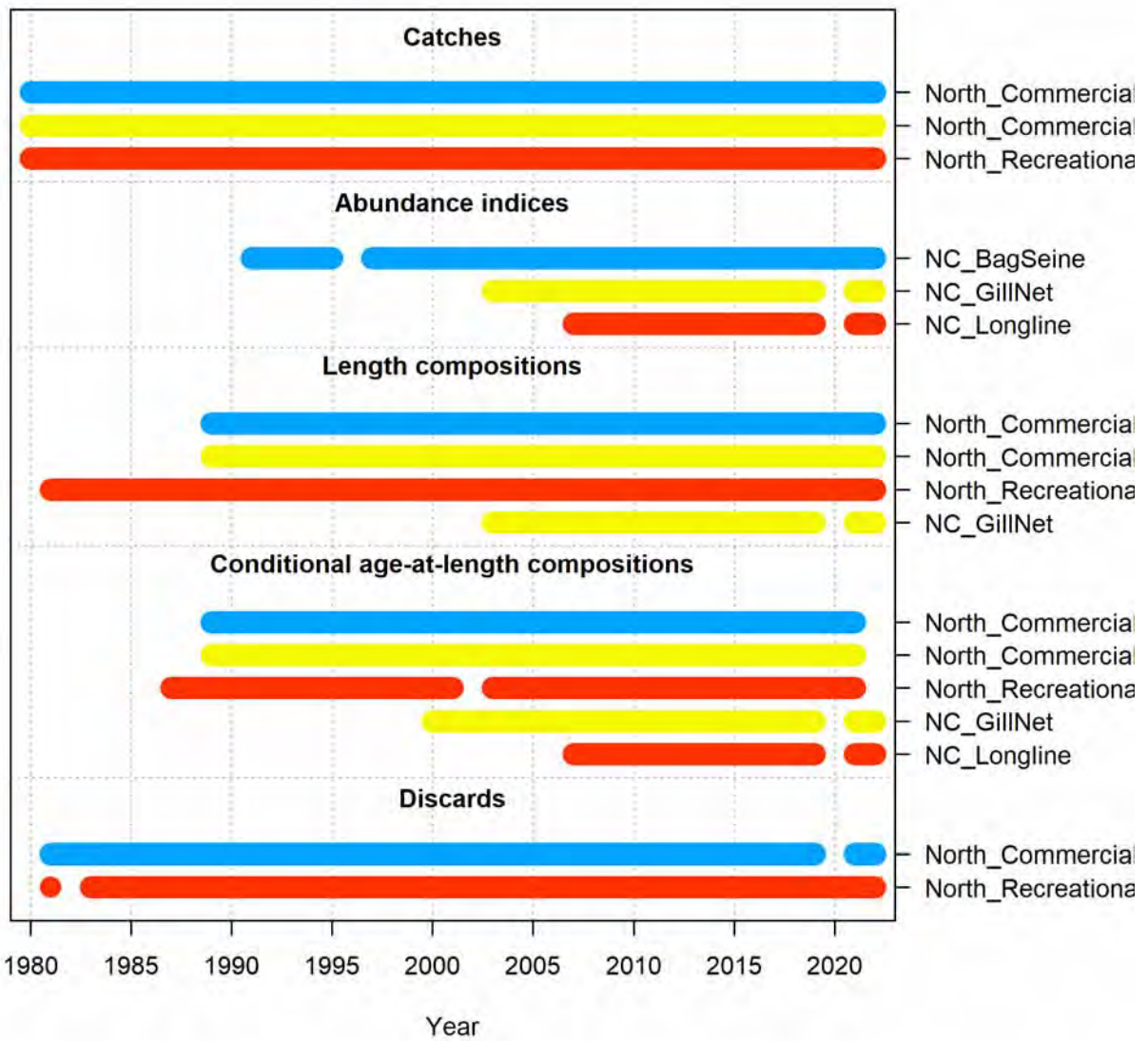
**Figure 122. Age distribution of red drum captured during the Florida 183 Meter Haul Seine Survey (FL\_183\_HaulSeine).**



**Figure 123.** Annual apparent survival estimates of red drum from a Cormack-Jolly-Seber mark-recapture model developed using conventional tagging data from the South Carolina Department of Natural Resources’ fisheries-independent monitoring programs. Data include releases from 1990-2021, with recaptures from 1990-2022. A) Annual apparent survival estimates are a function of red drum age + time. B) Annual apparent survival estimates are a function of red drum age +  $s(\text{time})$ .



**Figure 124.** Relative error for southern SS EM three-year F ratio estimates (a), mature female number estimates (b), and subadult number estimates (c) from the Base scenario (data with observation error), no observation error data with the Base scenario model (No Obs Error), and no observation error data with the Base scenario and correctly specified growth and natural mortality (No Obs Error TruGrowM). The black dashed line indicates no error.



**Figure 125. Data time series used in SS estimated selectivity model for the northern stock.**

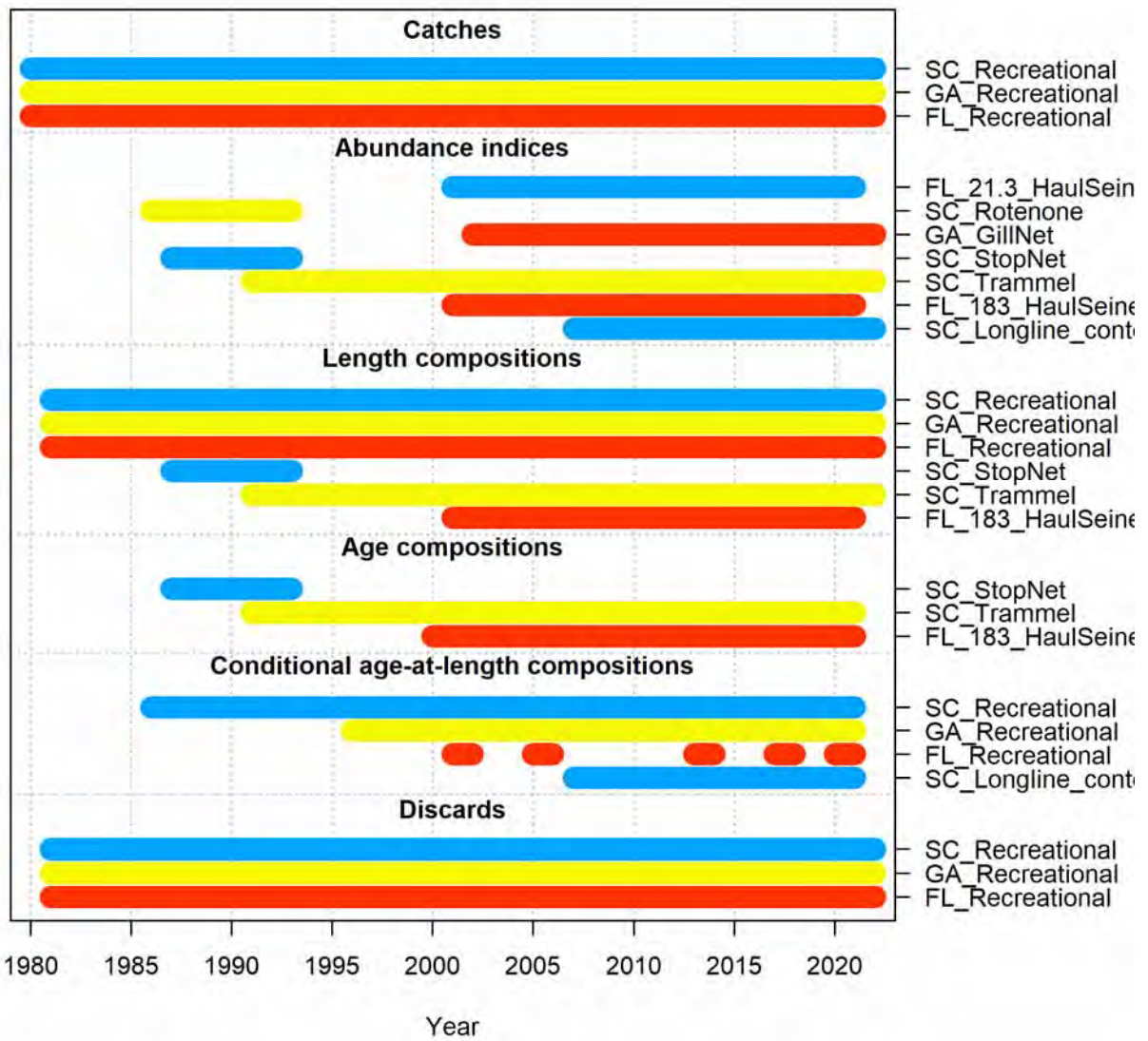


Figure 126. Data time series used in SS base model for the southern stock.



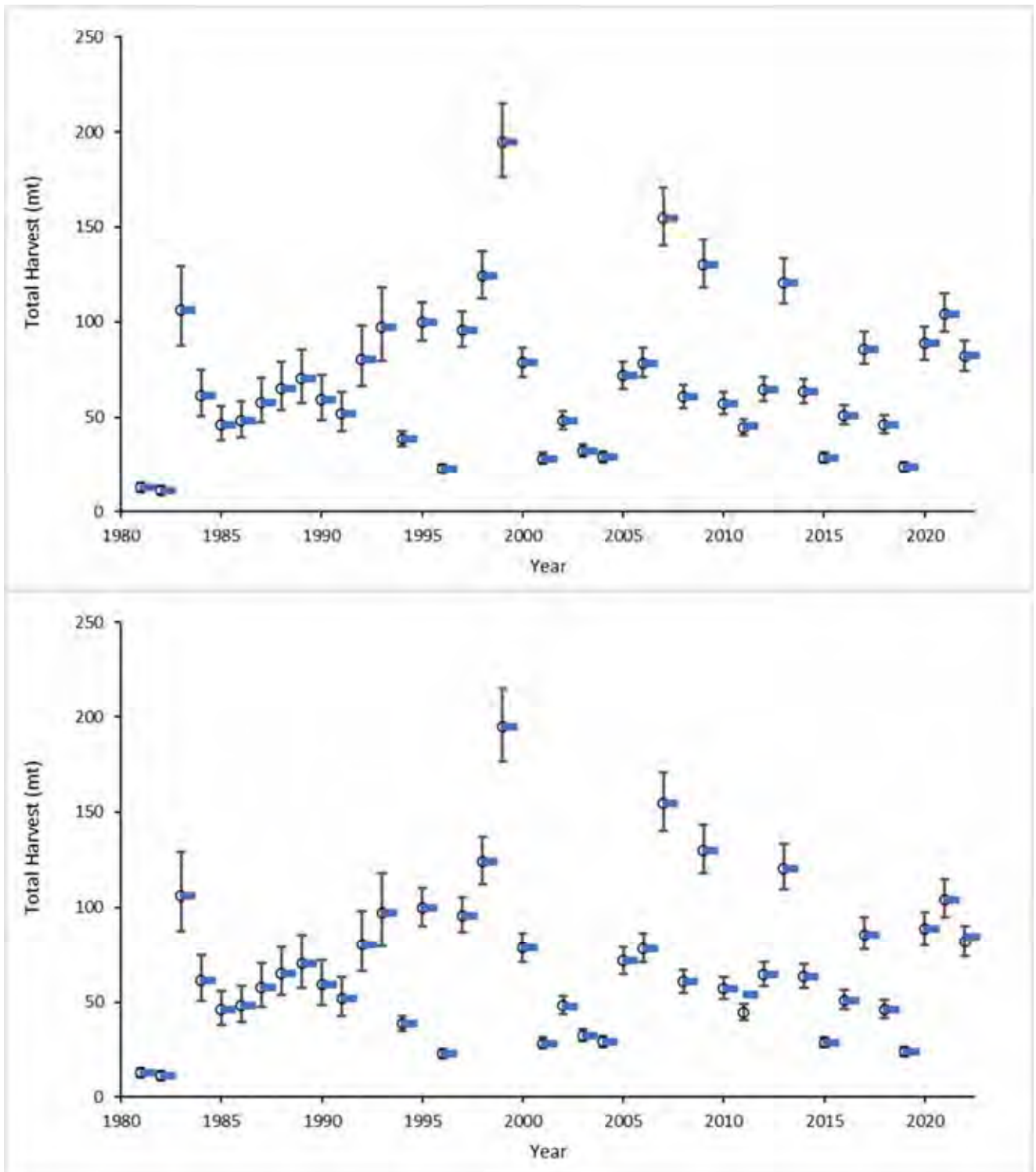
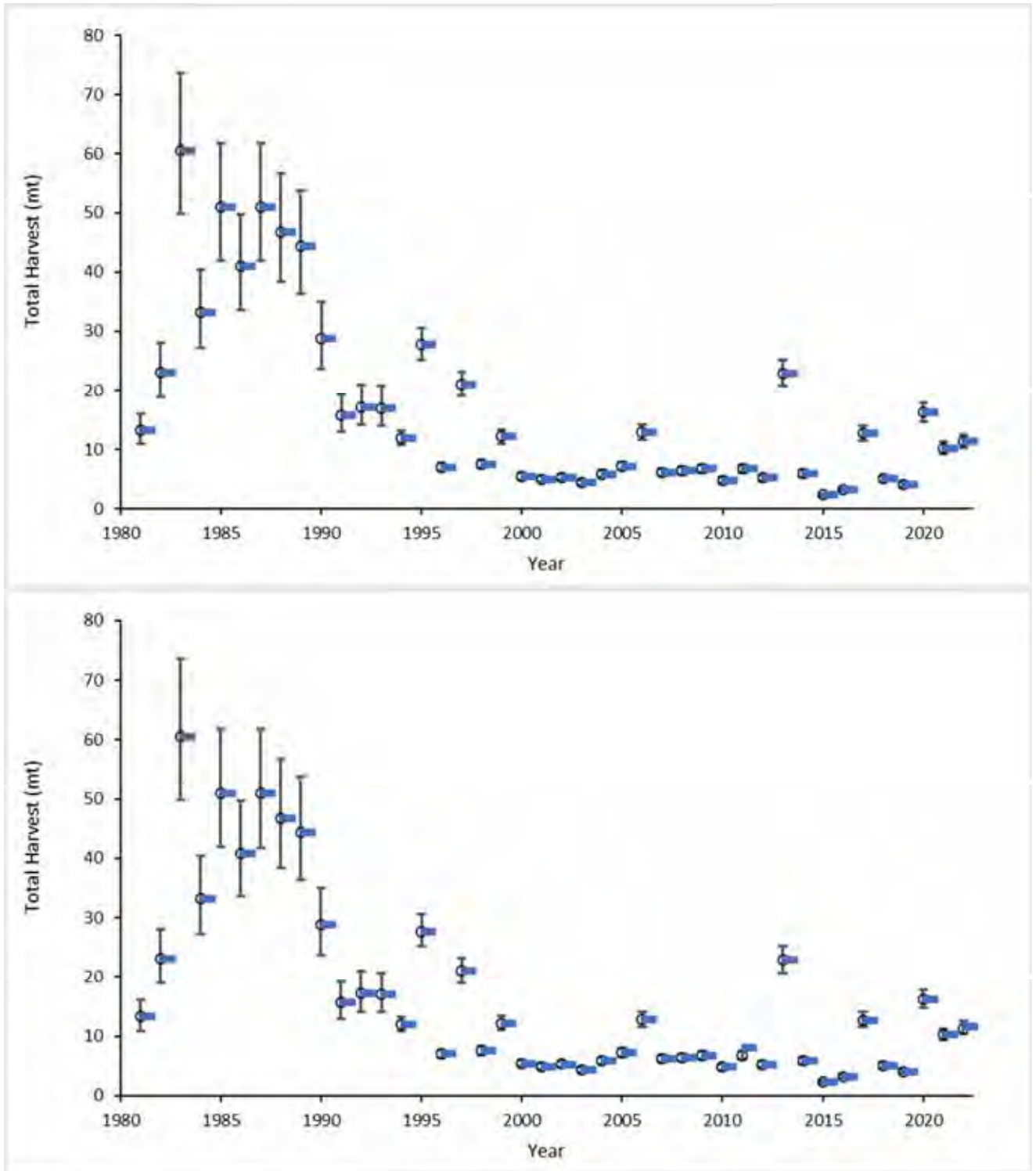
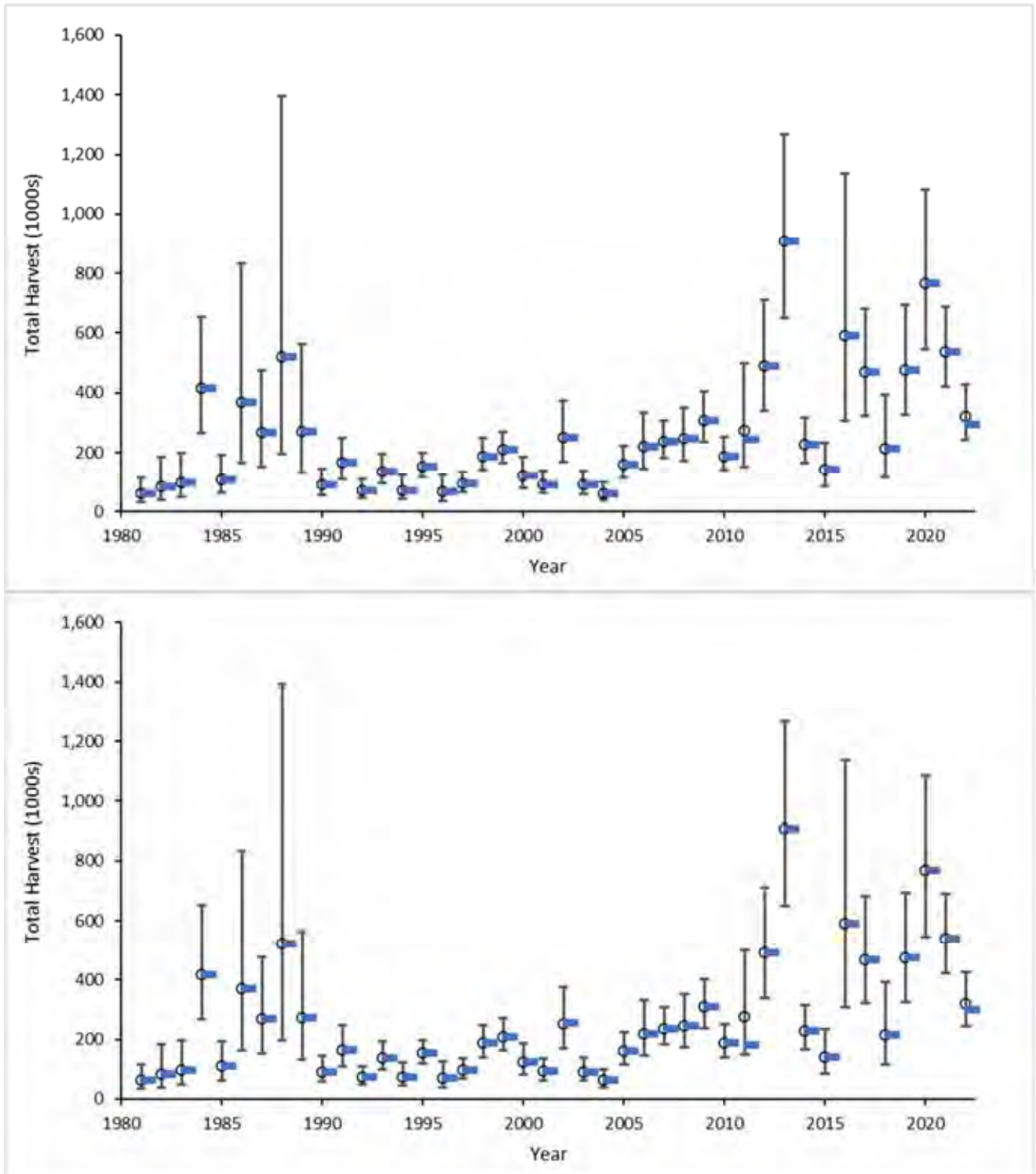


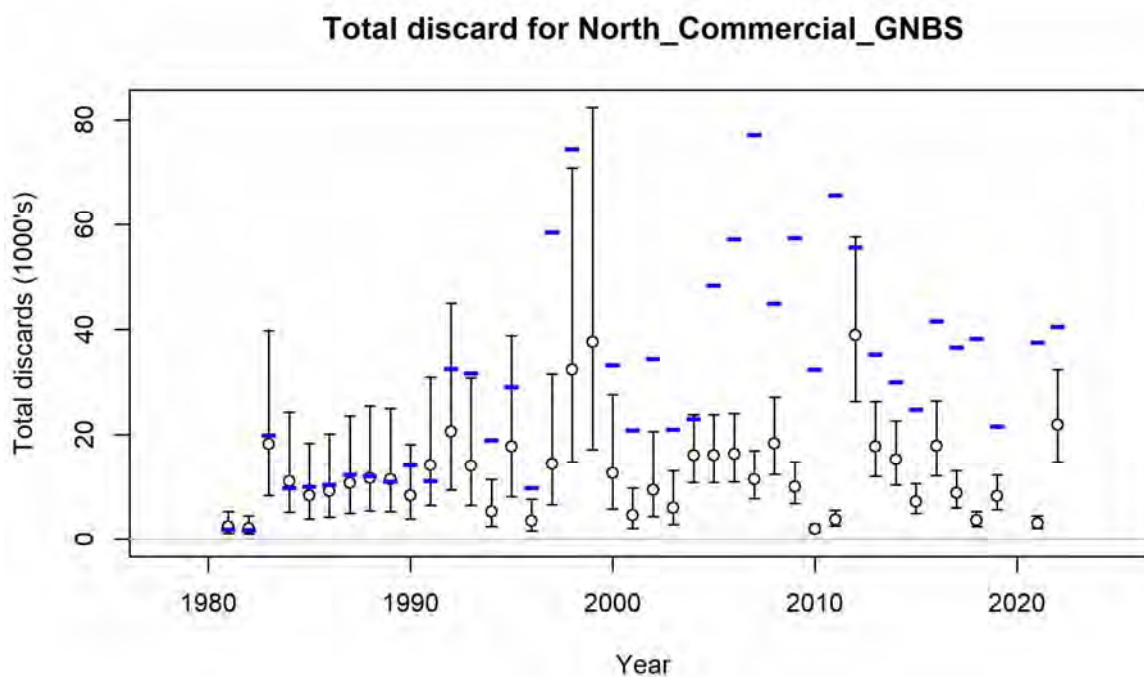
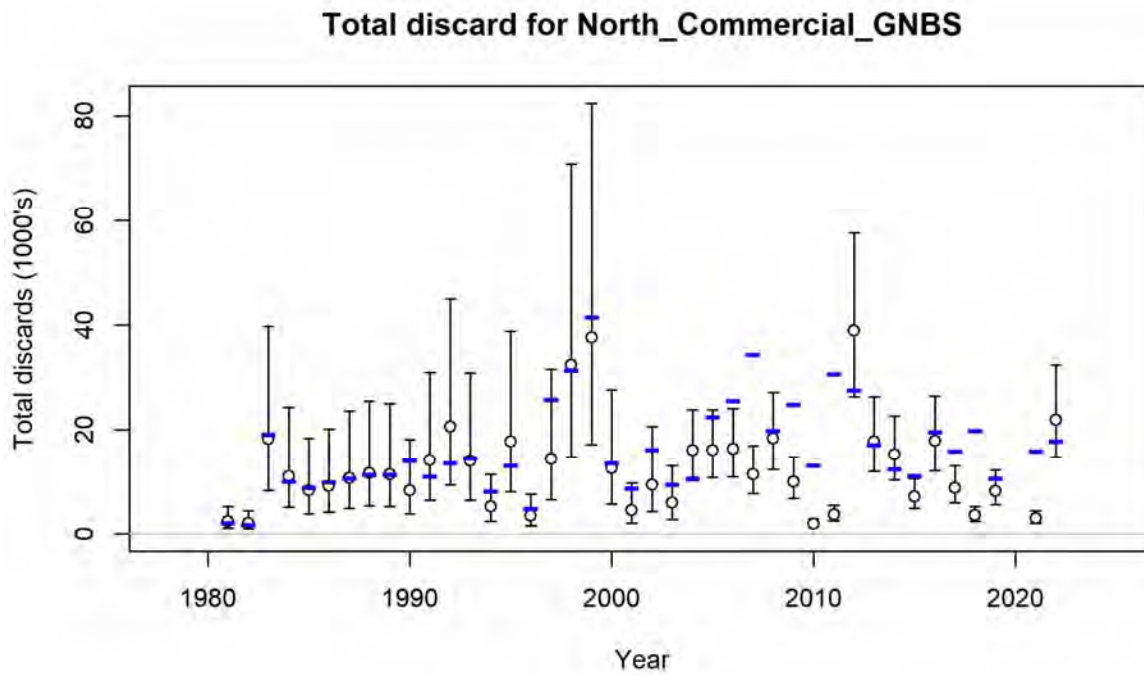
Figure 127. Observed and estimated catches for the North\_Commercial\_GNBS fleet for the northern stock SS estimated selectivity model (top) and hybrid selectivity model (bottom).



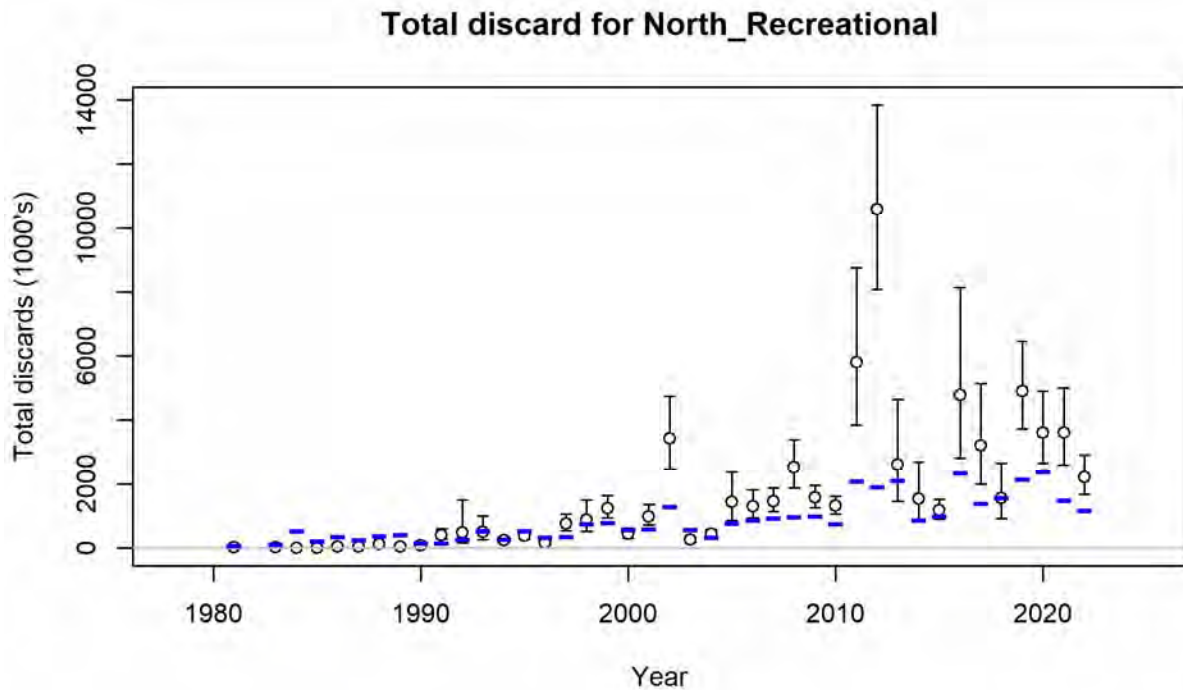
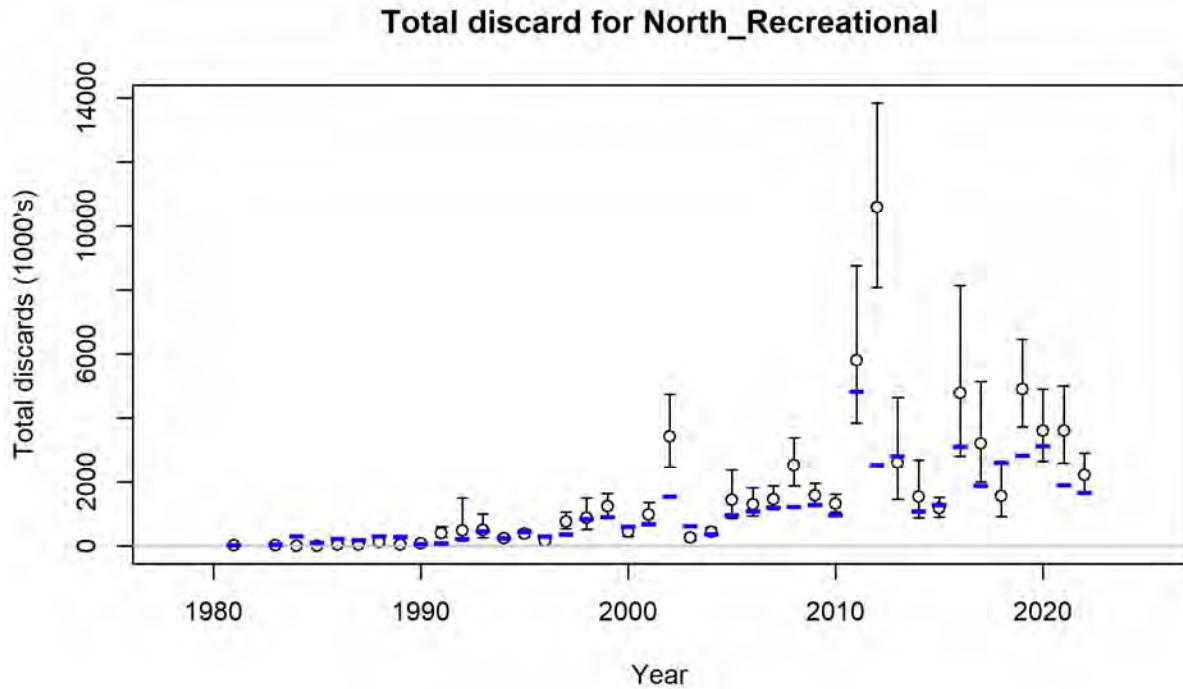
**Figure 128.** Observed and estimated catches for the North\_Commercial\_Other fleet for the northern stock SS estimated selectivity model (top) and hybrid selectivity model (bottom).



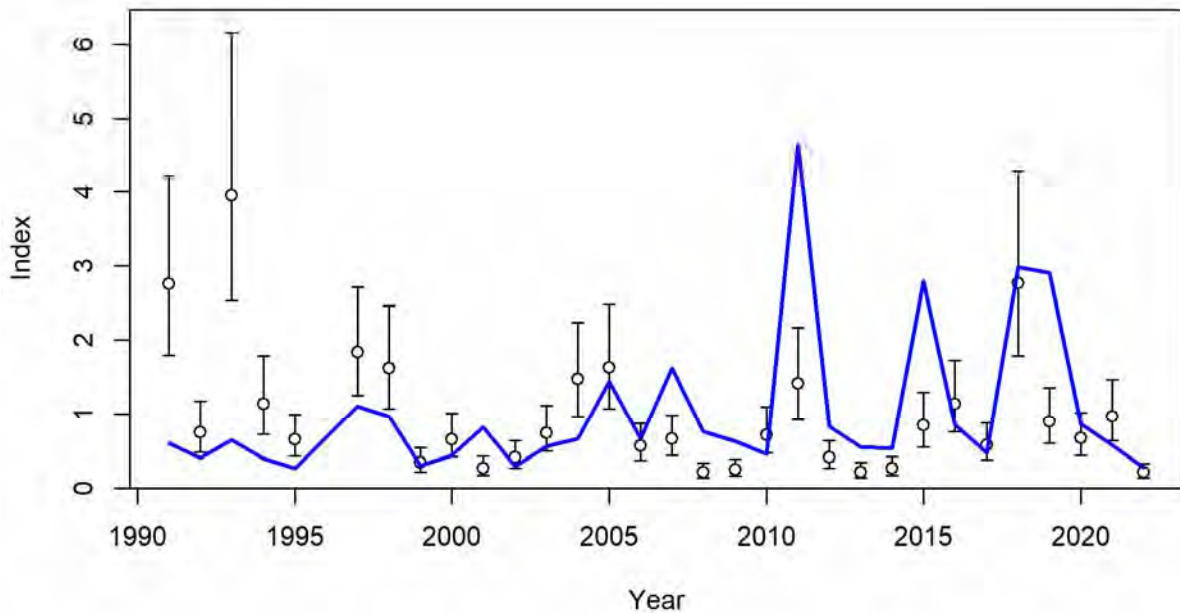
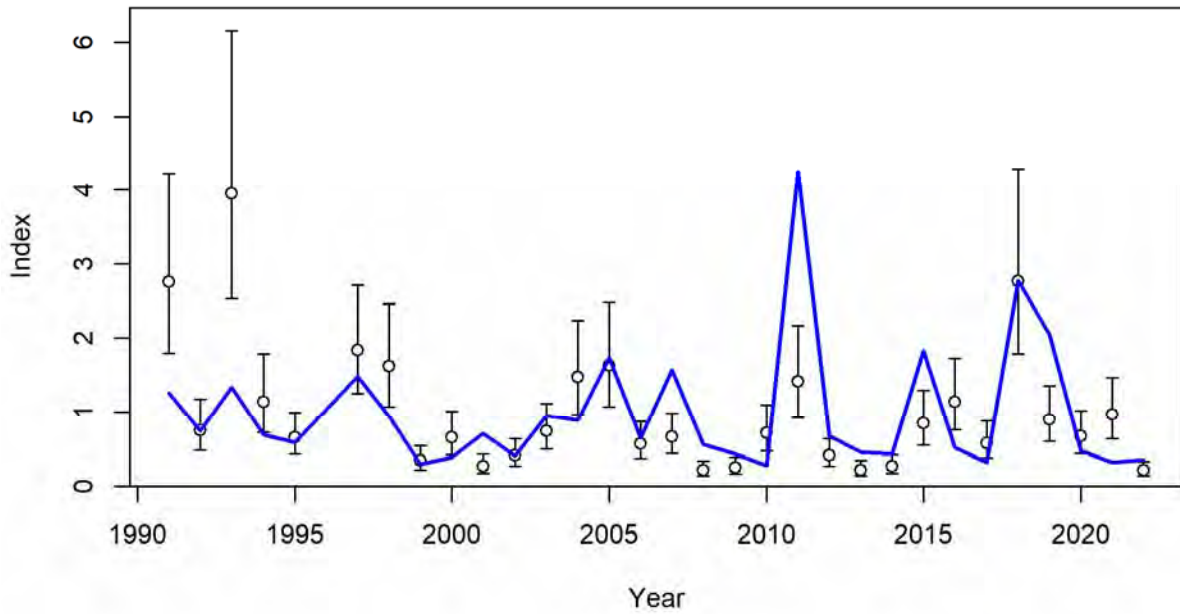
**Figure 129.** Observed and estimated catches for the North\_Recreational fleet for the northern stock SS estimated selectivity model (top) and hybrid selectivity model (bottom).



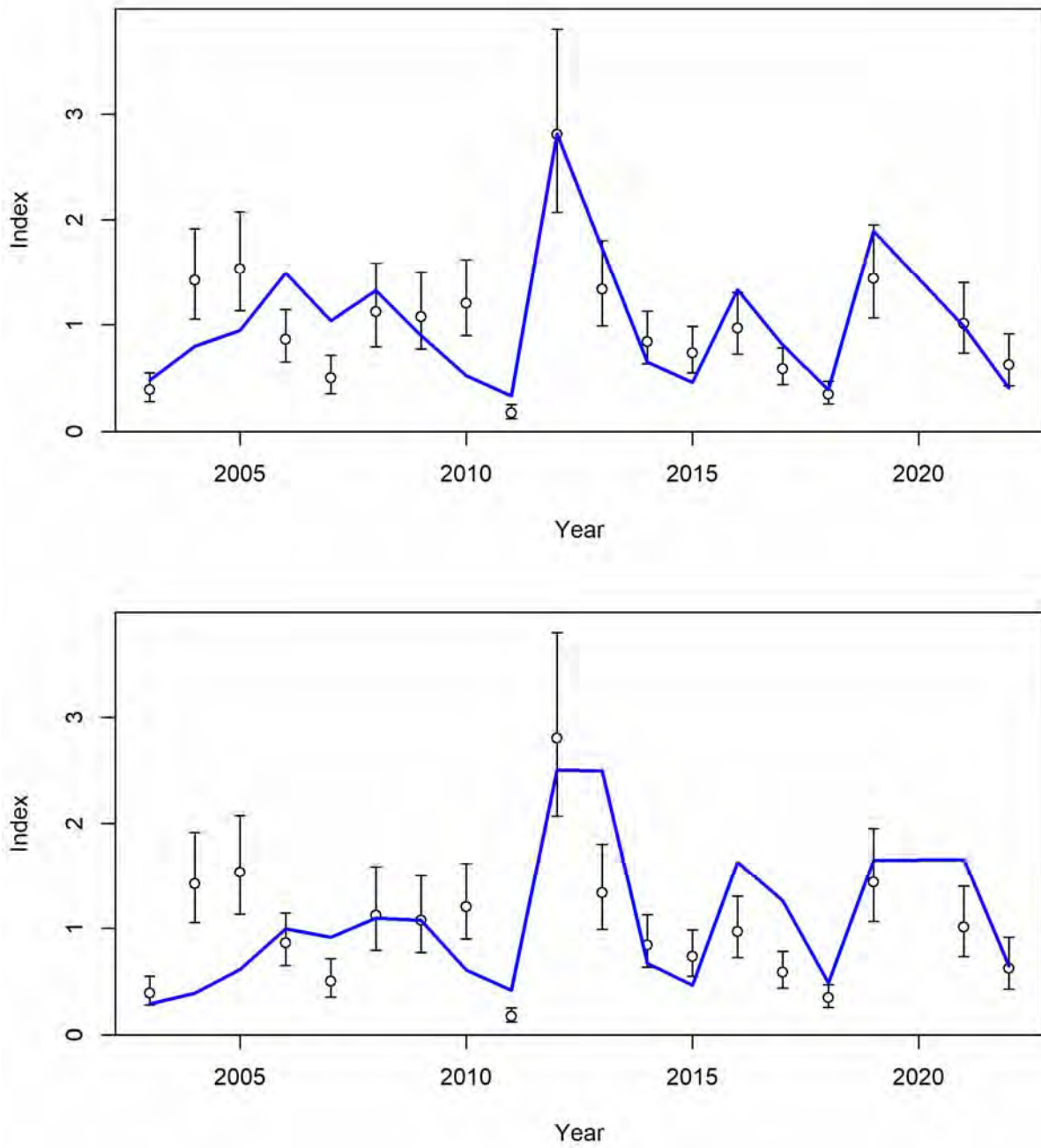
**Figure 130. Observed and estimated discards (in 1000's of fish) for the commercial gill net beach seine fleet for the northern stock SS estimated selectivity model (top) and hybrid selectivity model (bottom).**



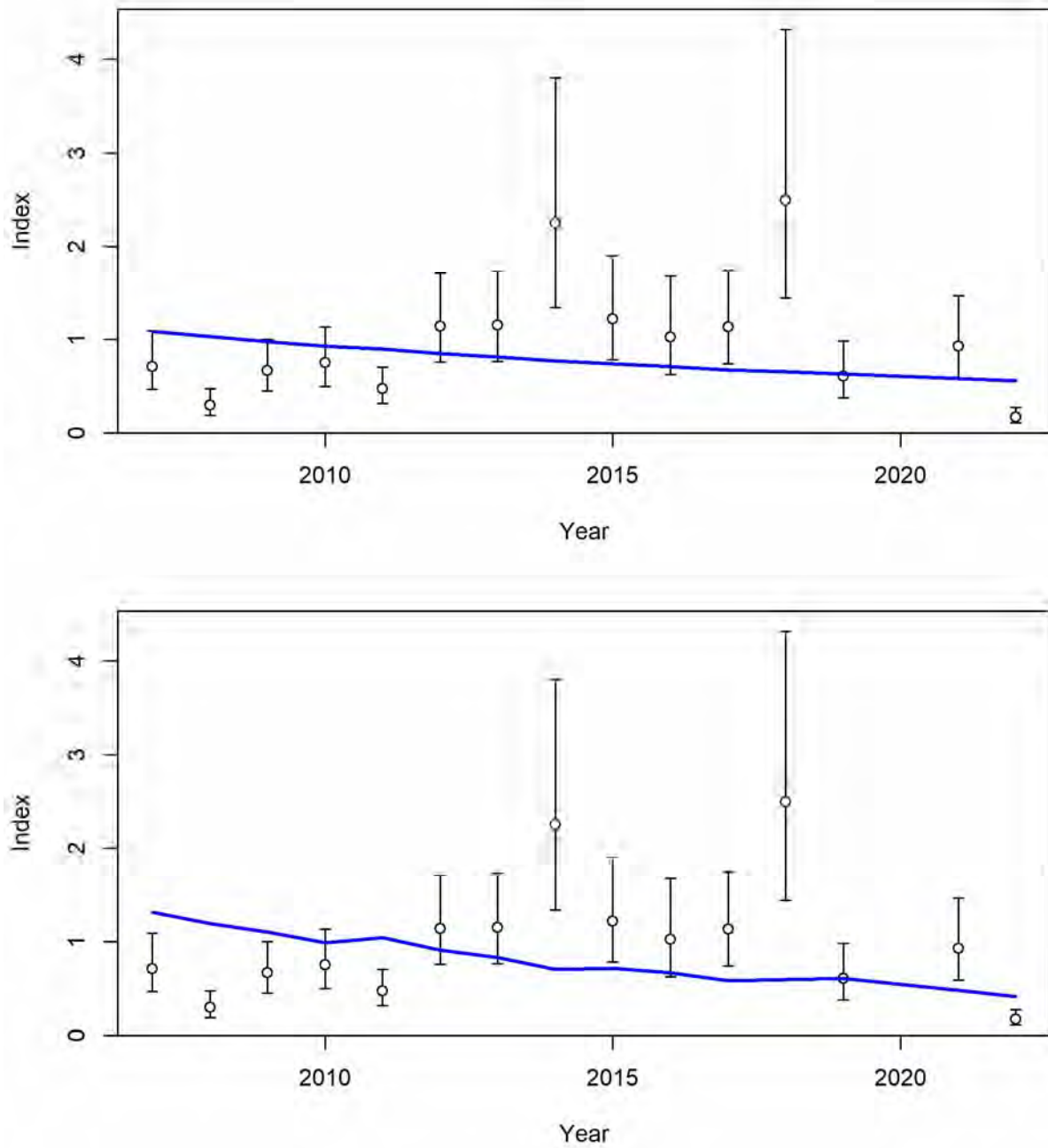
**Figure 131. Observed and estimated discards (in 1000's of fish) for the recreational fleet for the northern stock SS estimated selectivity model (top) and hybrid selectivity model (bottom).**



**Figure 132.** Observed and estimated index values for the NC\_BagSeine survey for the northern stock SS estimated selectivity model (top) and hybrid selectivity model (bottom).

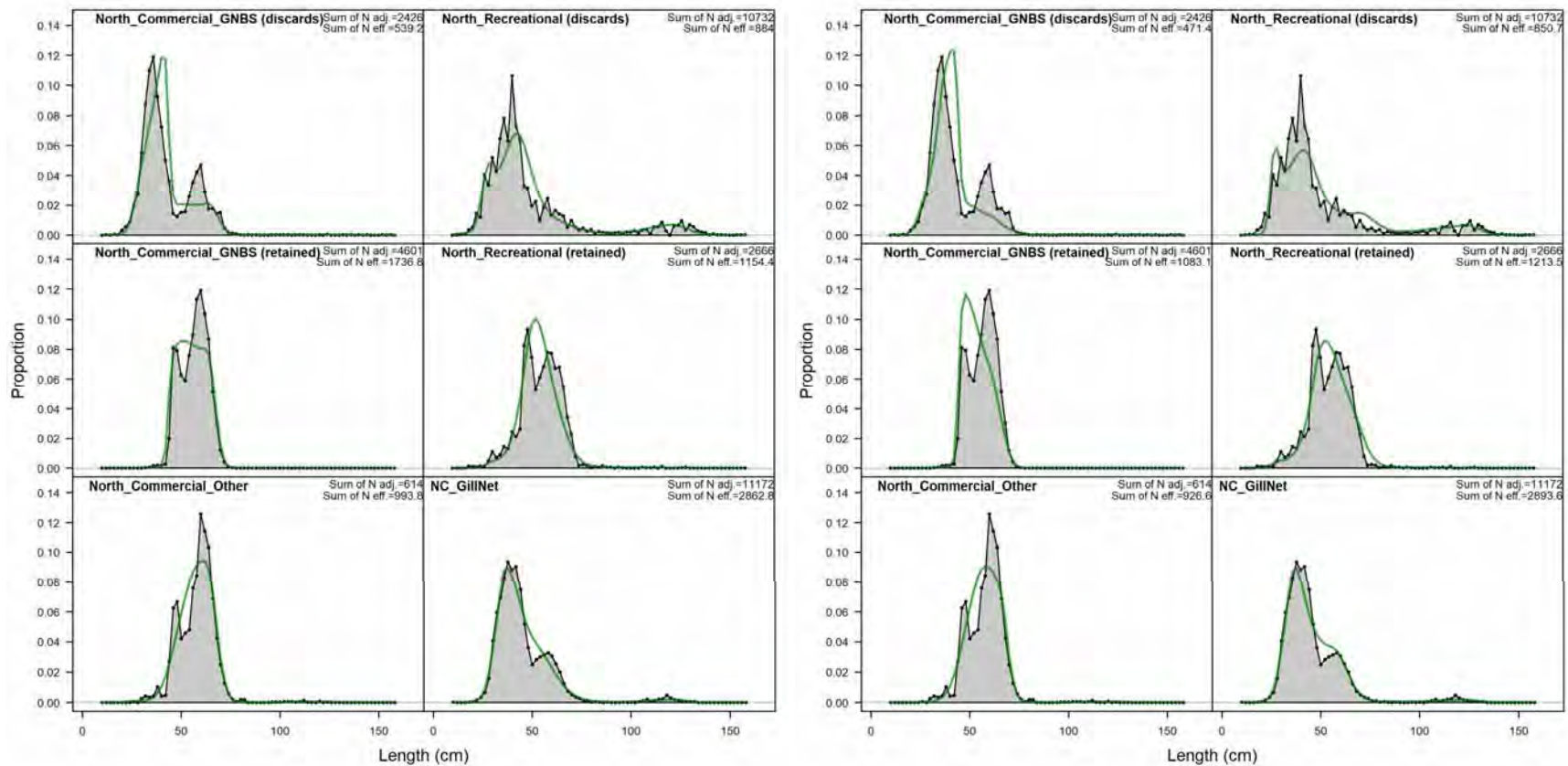


**Figure 133.** Observed and estimated index values for the NC\_GillNet survey for the northern stock SS estimated selectivity model (top) and hybrid selectivity model (bottom).

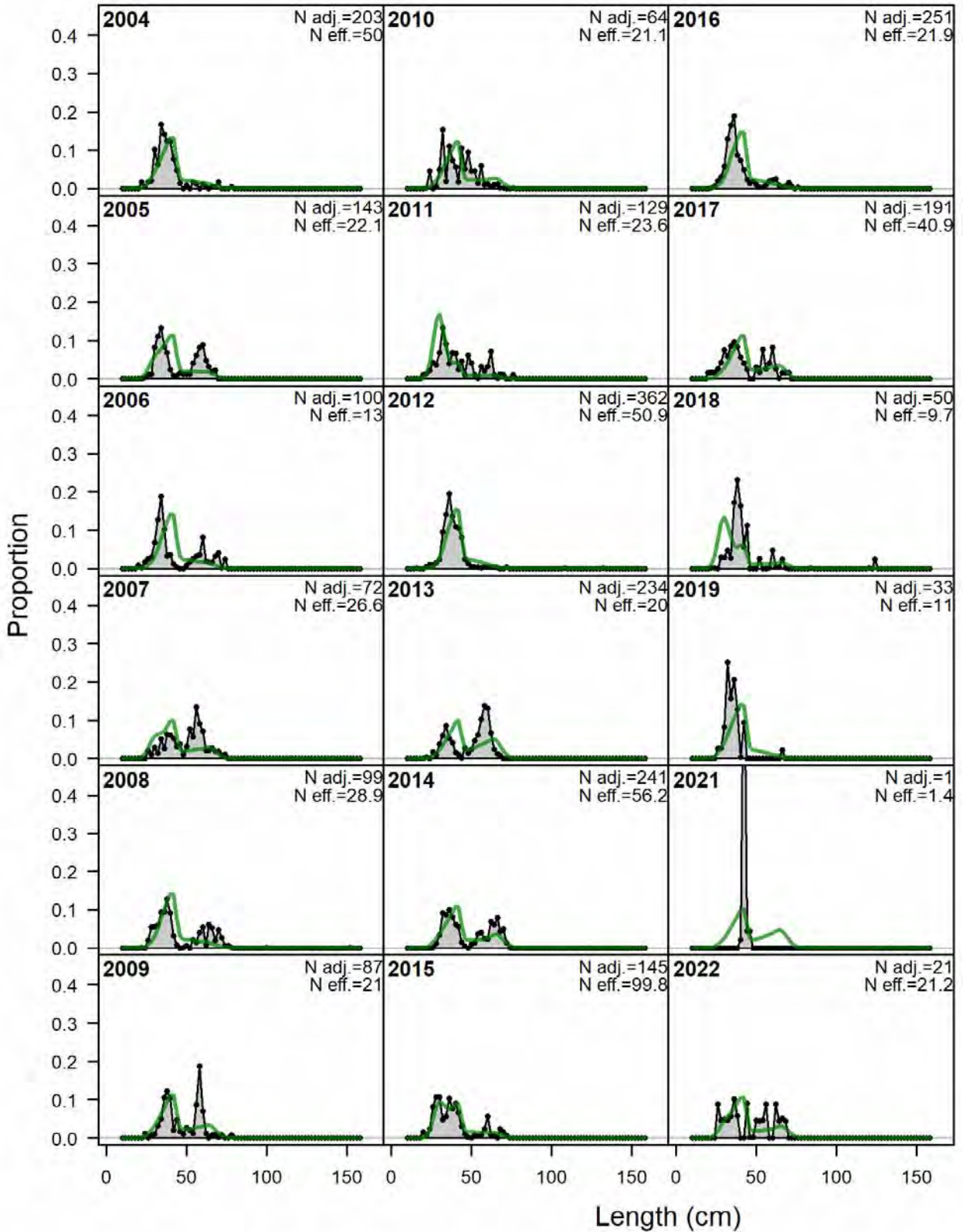


**Figure 134. Observed and estimated index values for the NC\_Longline survey for the northern stock SS estimated selectivity model (top) and hybrid selectivity model (bottom).**

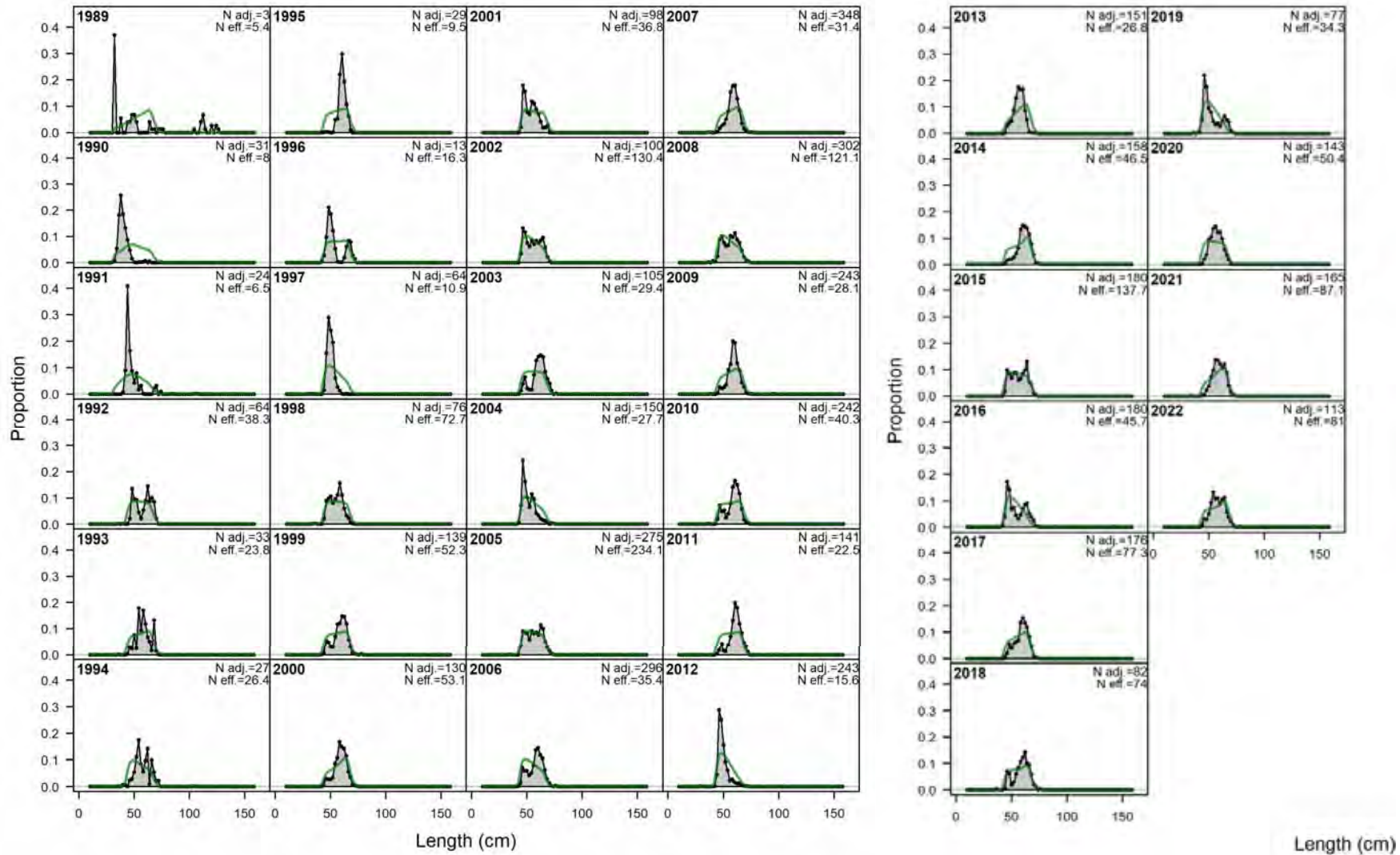




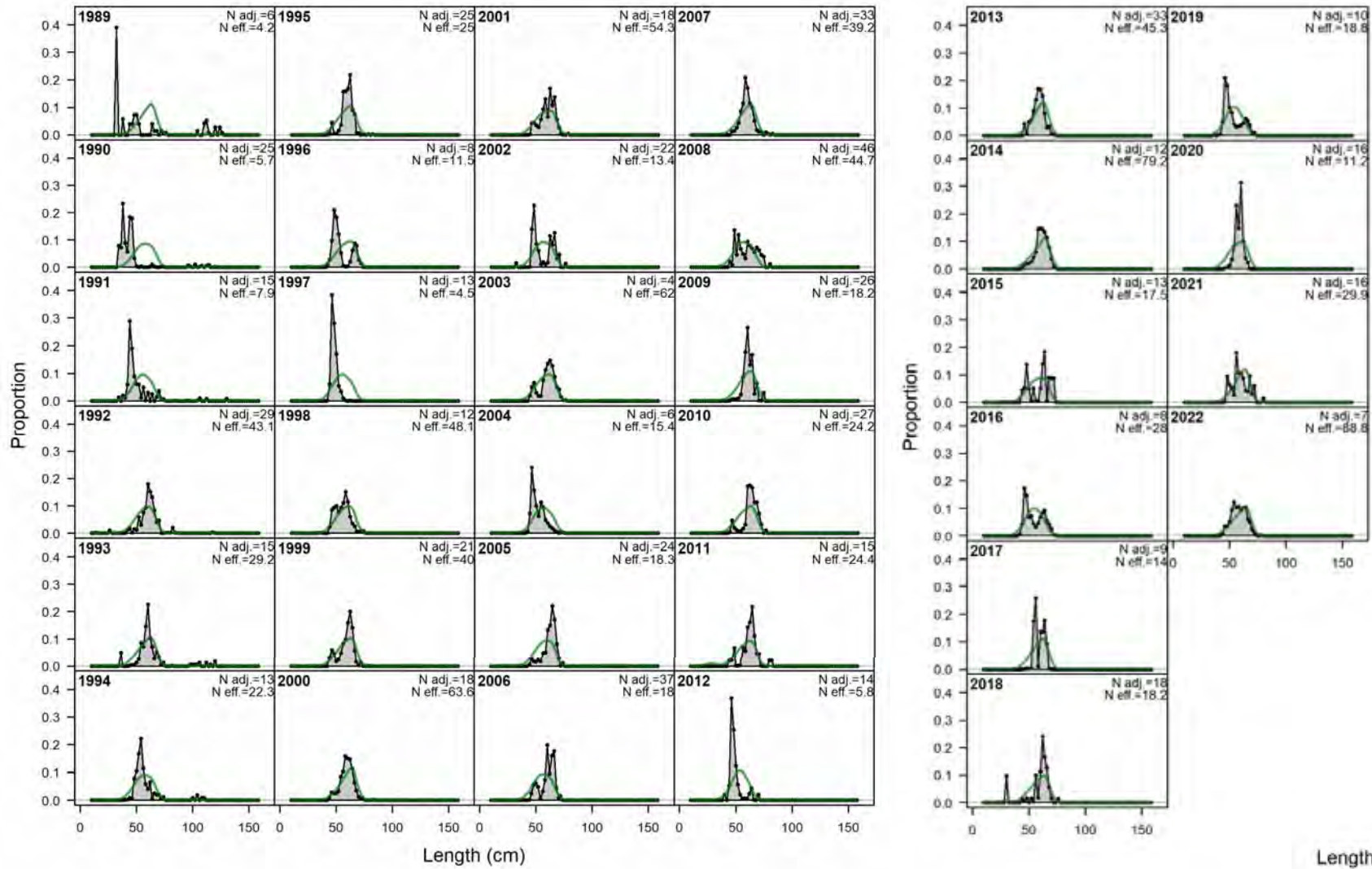
**Figure 135. Length compositions, aggregated across time by fleet/survey for the northern stock SS estimated selectivity model (left) and hybrid selectivity model (right).**



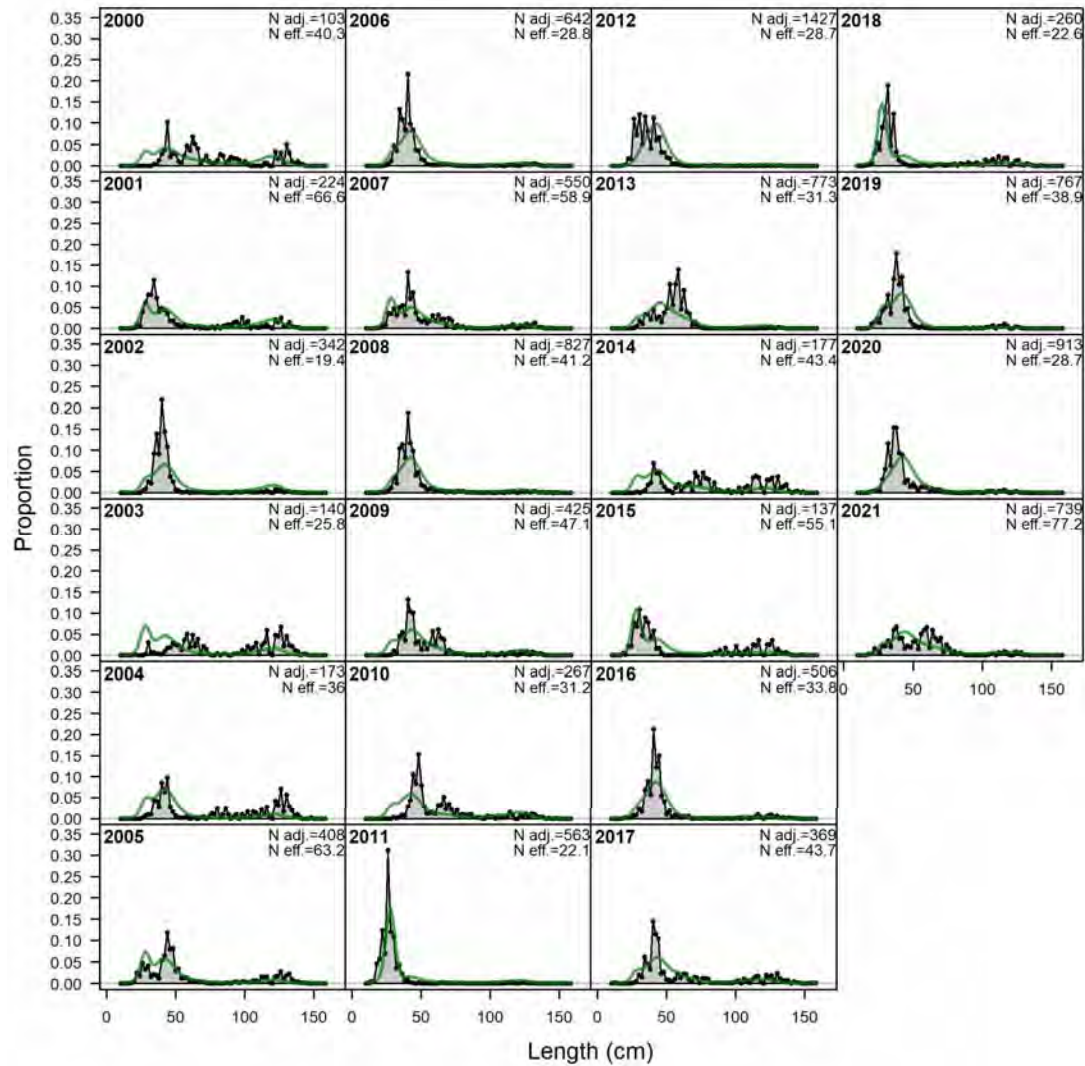
**Figure 136. Annual length compositions for the North\_Commercial\_GNBS discards for the northern stock SS estimated selectivity model.**



**Figure 137. Annual length compositions for the North\_Commercial\_GNBS harvest for the northern stock SS estimated selectivity model.**



**Figure 138. Annual length compositions for the North\_Commercial\_Other harvest for the northern stock SS estimated selectivity model.**



**Figure 139. Annual length compositions for the North\_Recreational discards for the northern stock SS estimated selectivity model.**

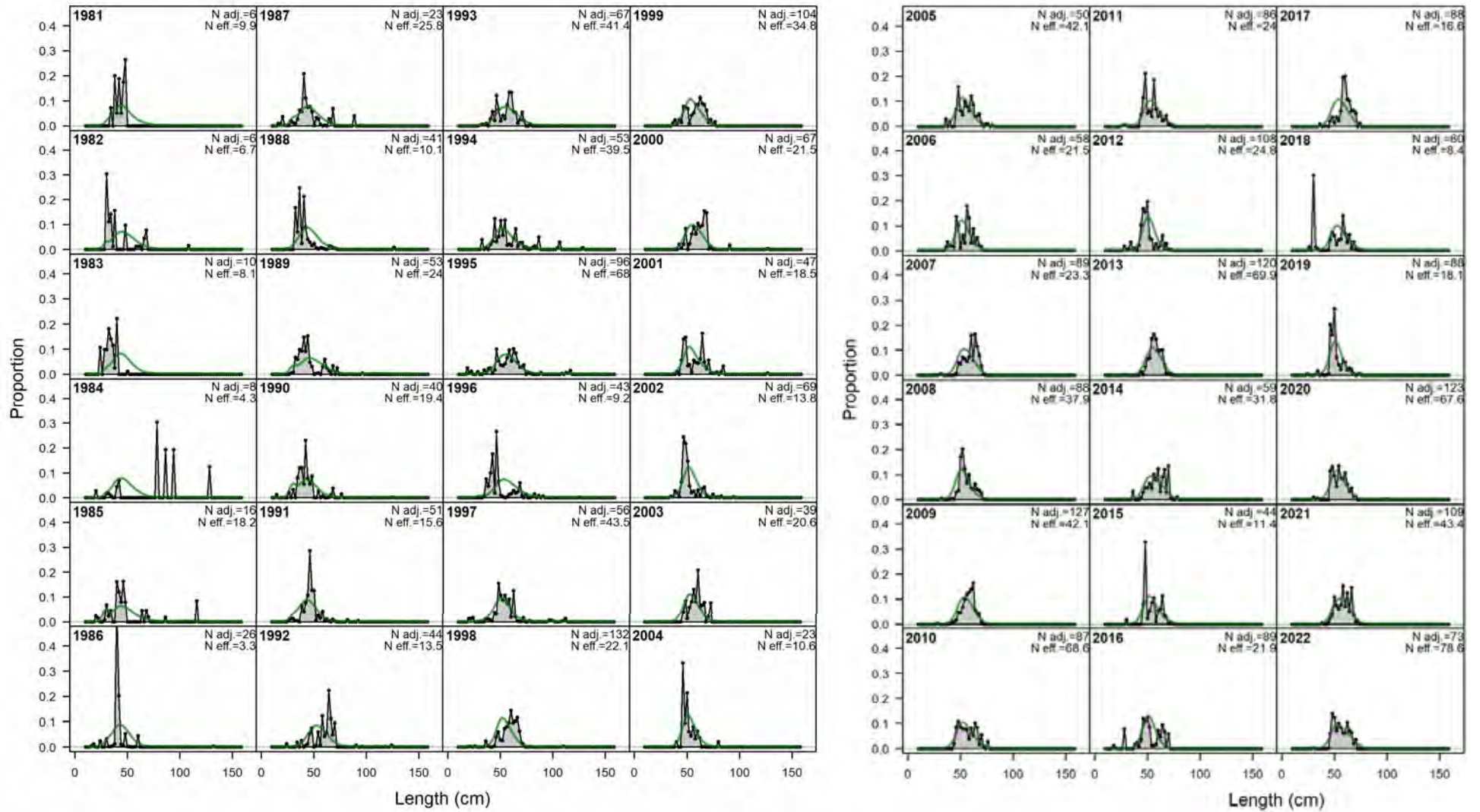
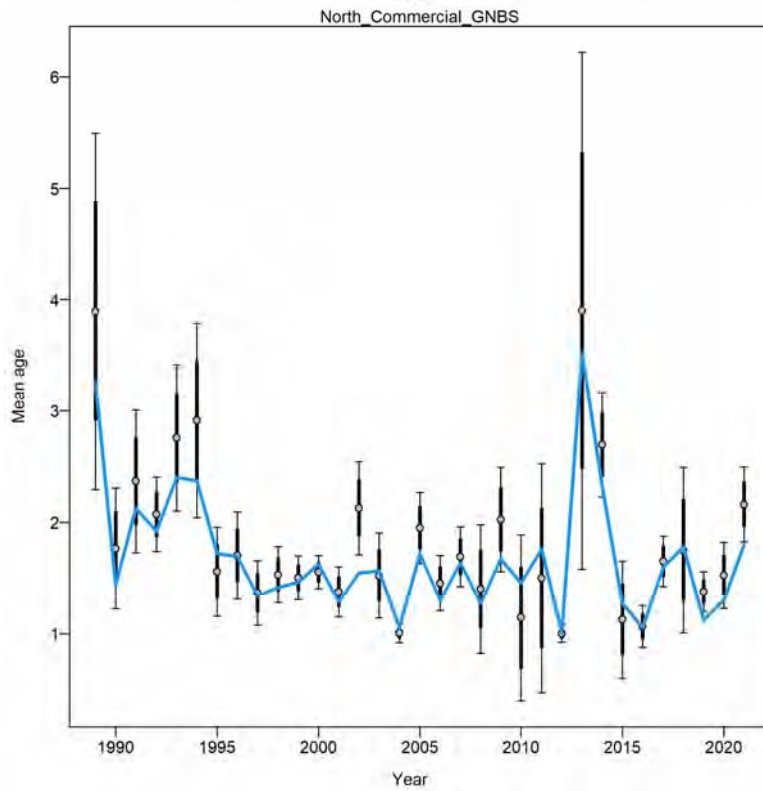
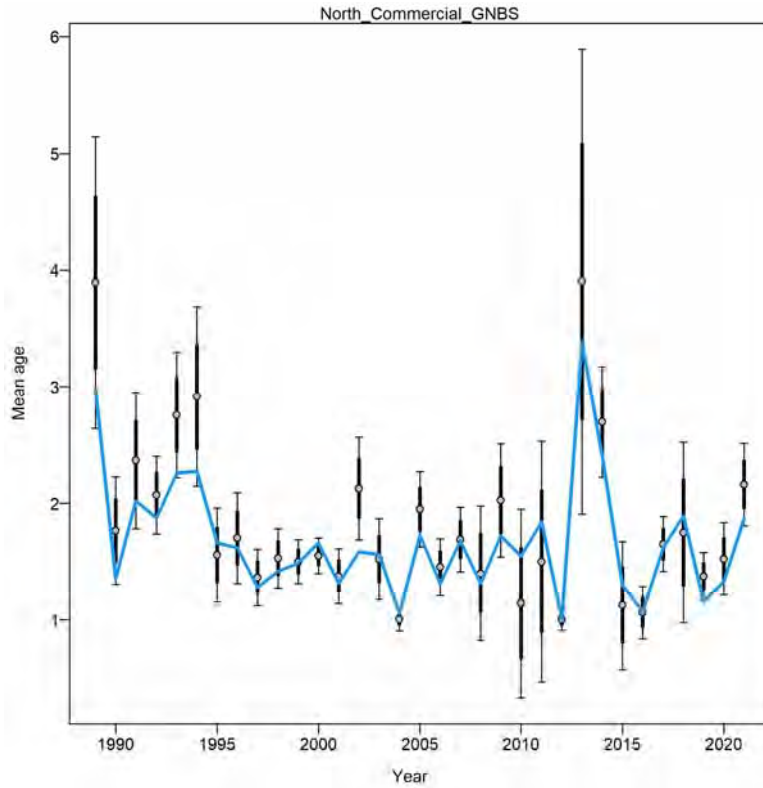
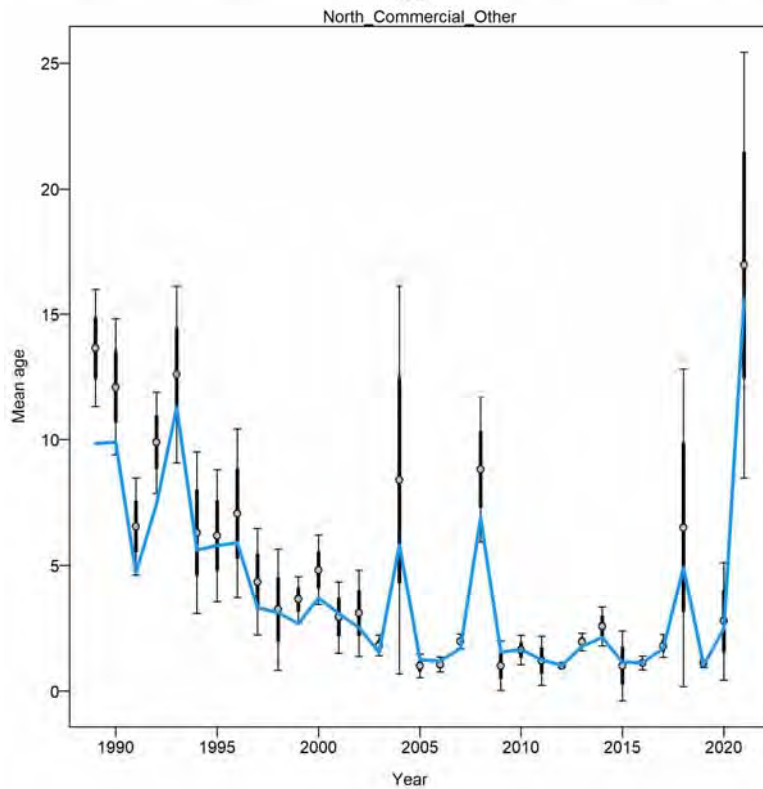
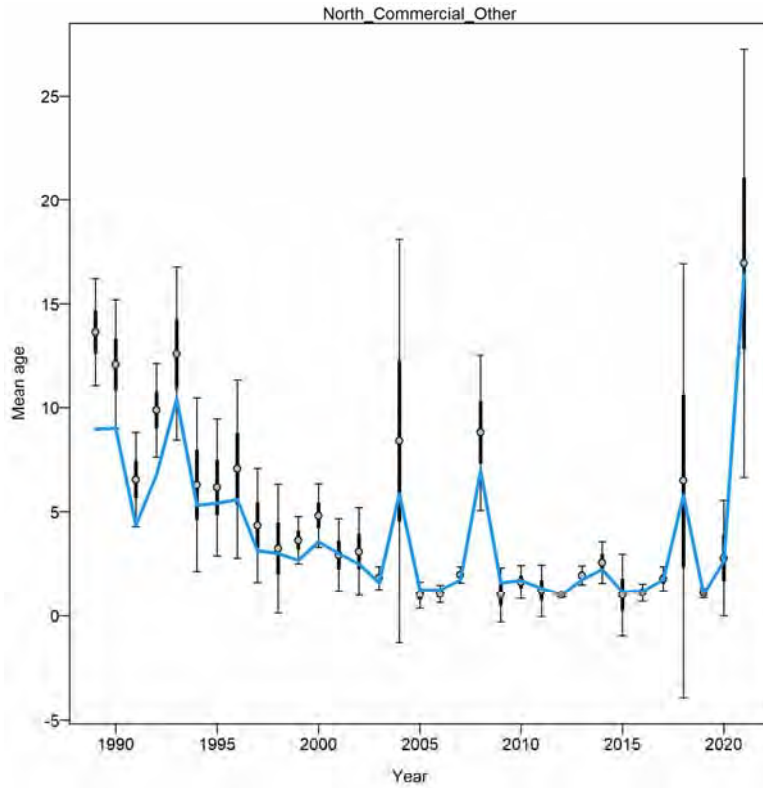


Figure 140. Annual length compositions for the North\_Recreational harvest for the northern stock SS estimated selectivity model.

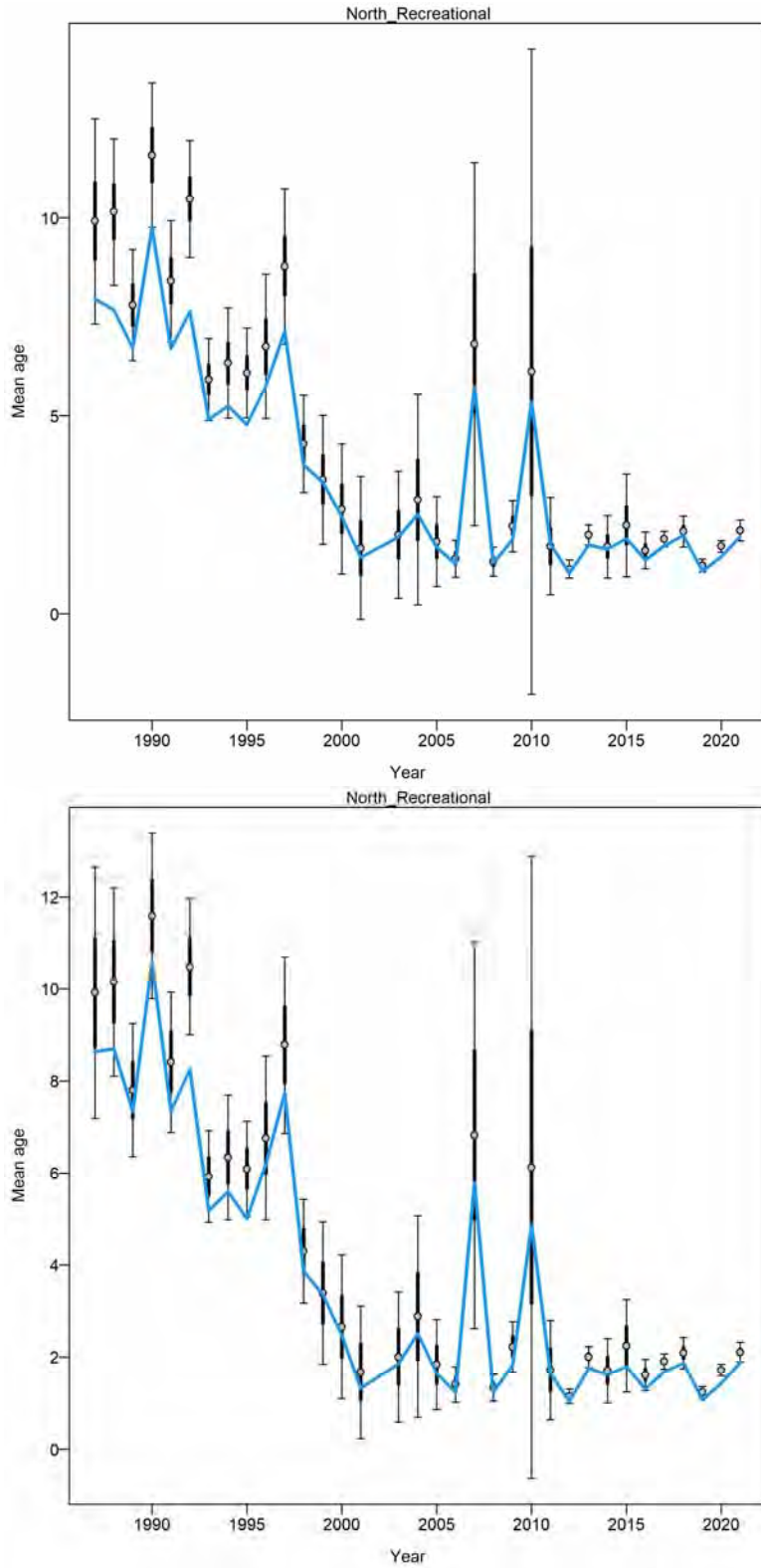


**Figure 141. Mean age from the conditional age data for the North\_Commercial\_GNBS fleet for the northern stock SS estimated selectivity model (top) and hybrid selectivity model (bottom).**

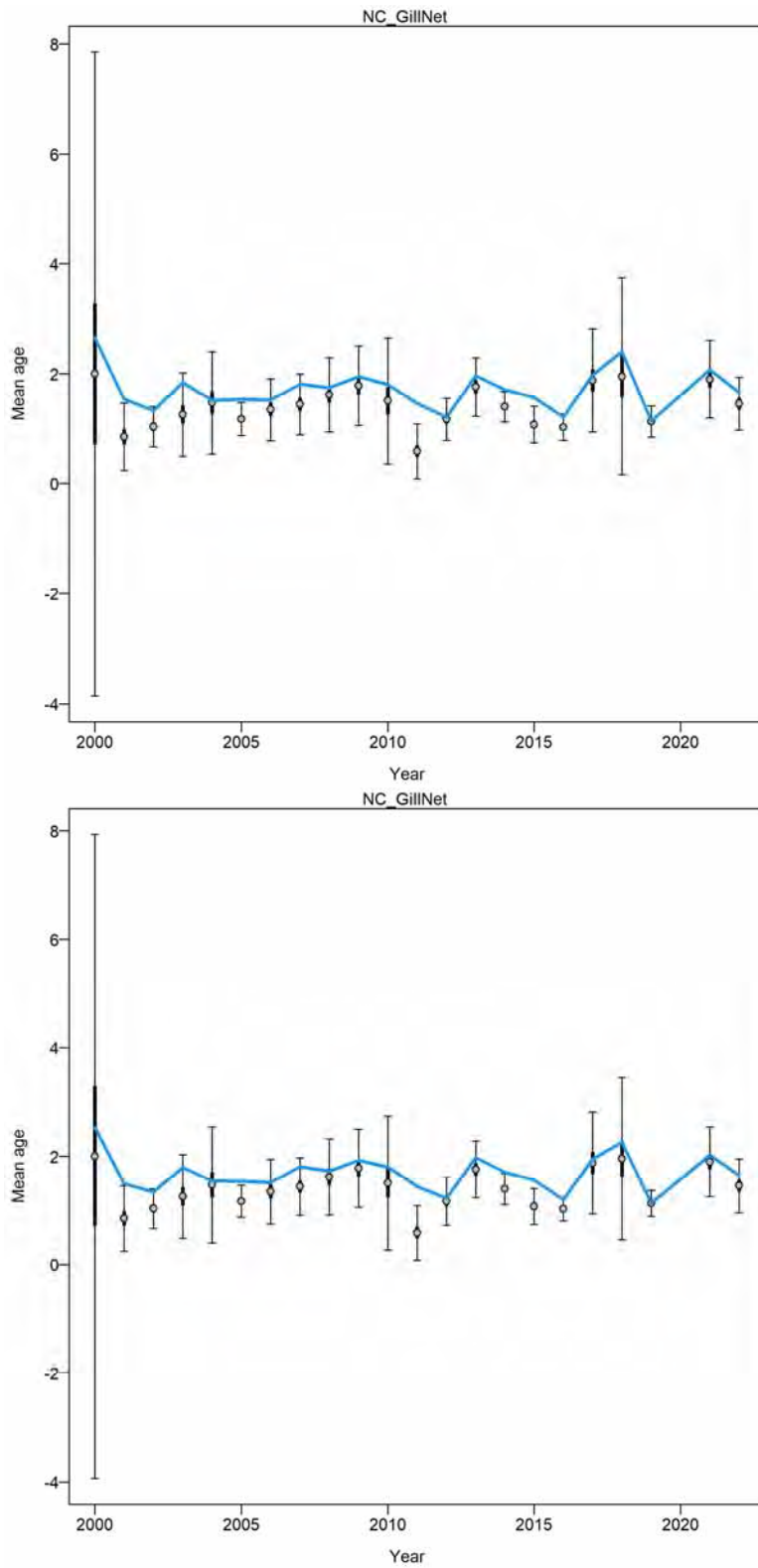


**Figure 142. Mean age from the conditional age data for the North\_Commercial\_Other fleet for the northern stock SS estimated selectivity model (top) and hybrid selectivity model (bottom).**

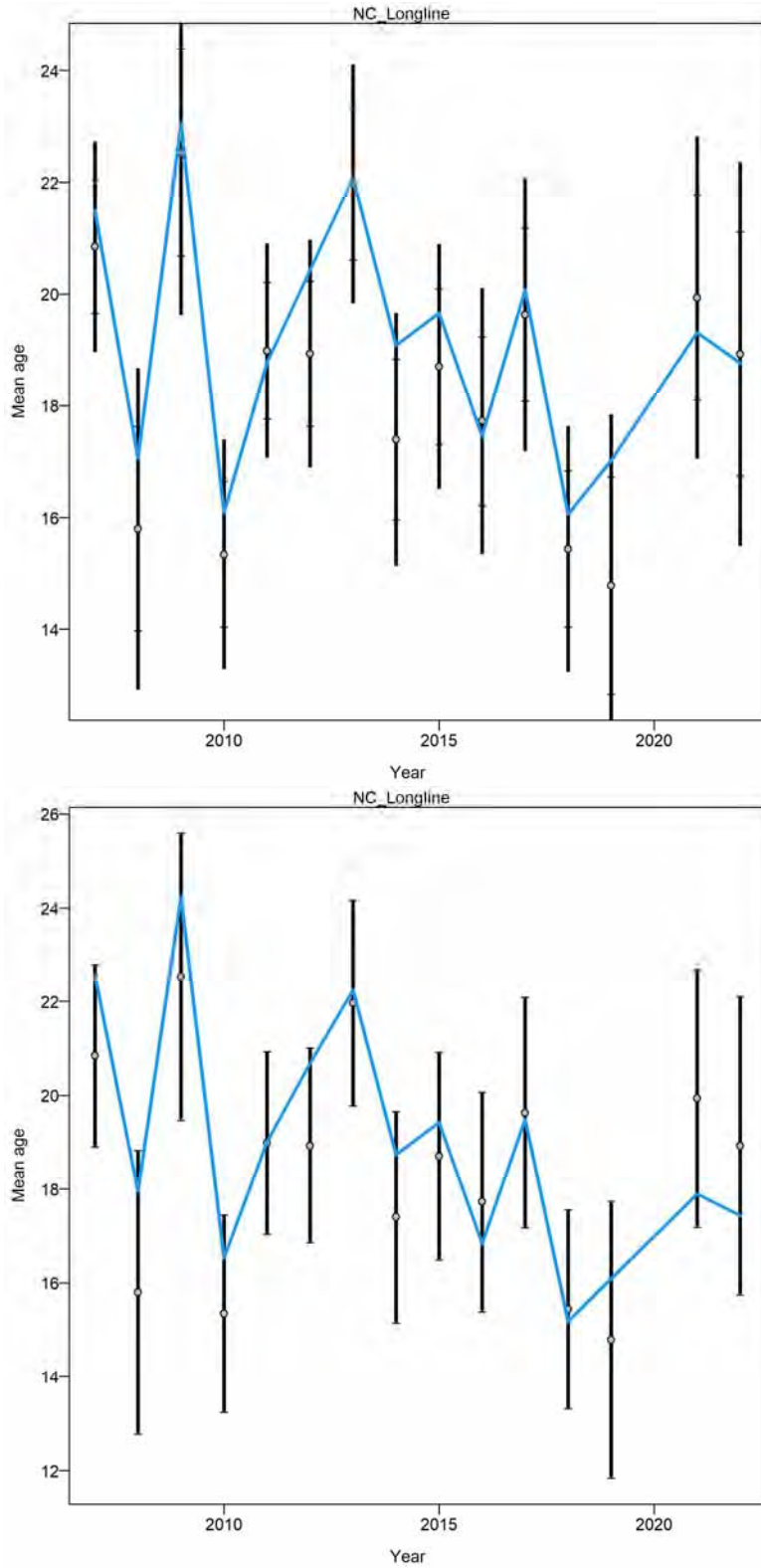




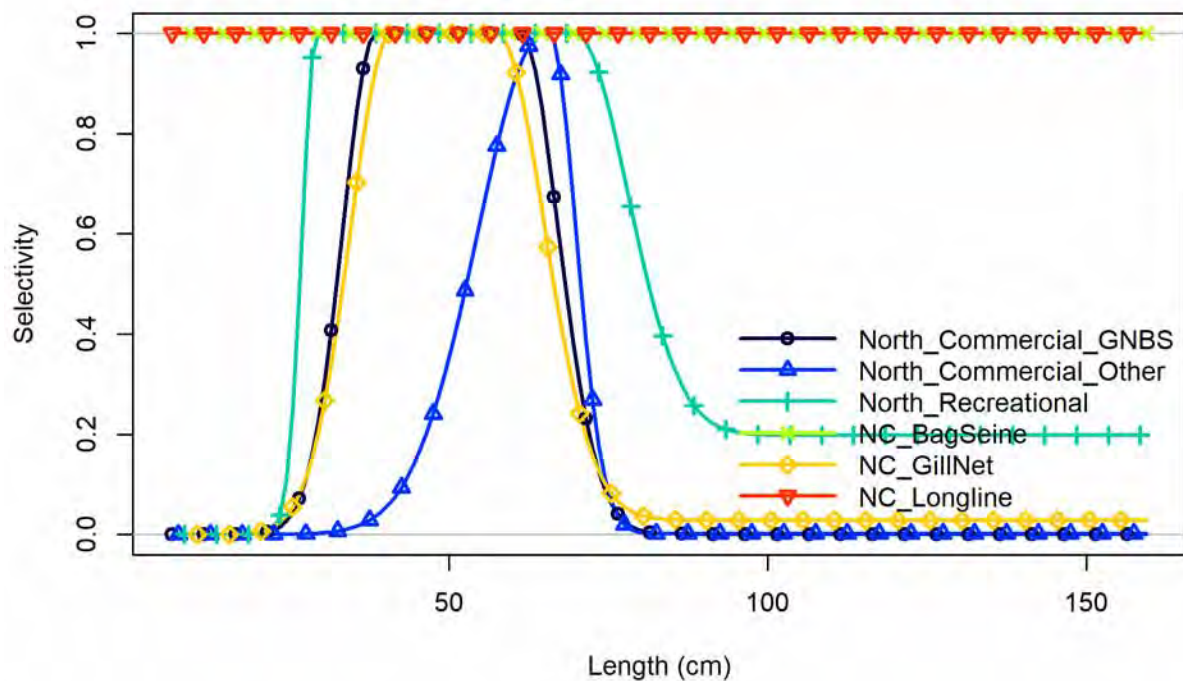
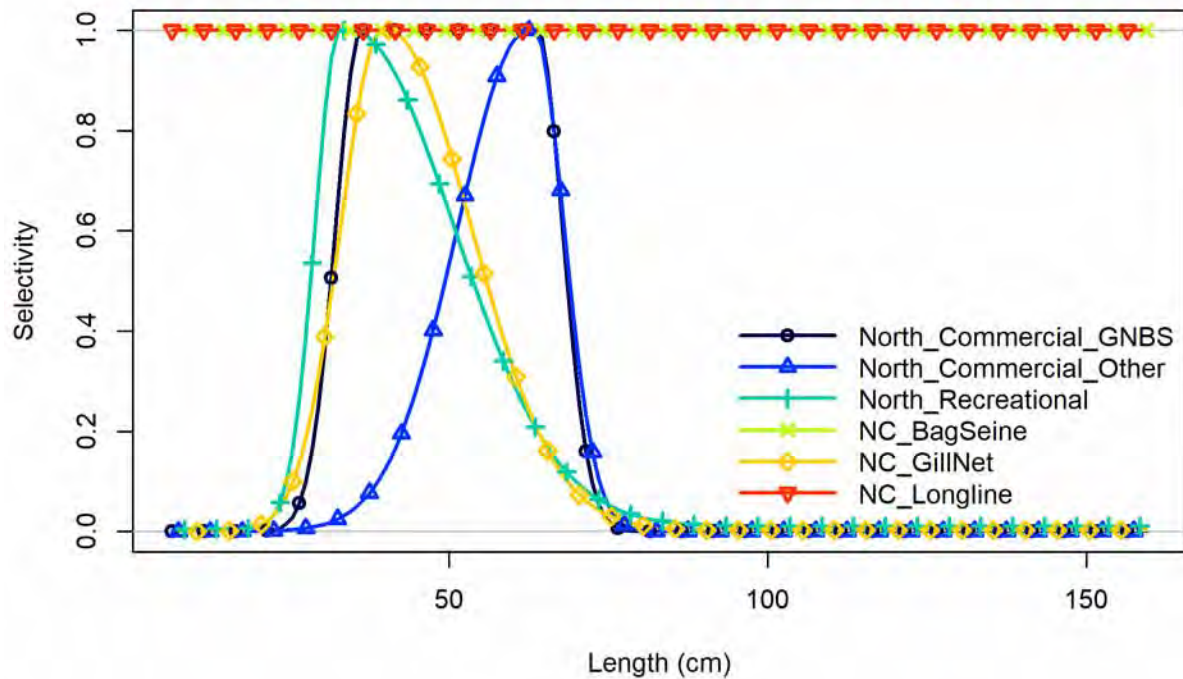
**Figure 143. Mean age from the conditional age data for the North\_Recreational fleet for the northern stock SS estimated selectivity model (top) and hybrid selectivity model (bottom).**



**Figure 144.** Mean age from the conditional age data for the NC\_GillNet survey for the northern stock SS estimated selectivity model (top) and hybrid selectivity model (bottom).



**Figure 145. Mean age from the conditional age data for the NC\_Longline survey for the northern stock SS estimated selectivity model (top) and hybrid selectivity model (bottom).**



**Figure 146.** Estimated length based selectivities for the northern stock SS estimated selectivity model (top) and hybrid selectivity model (bottom). The North\_Commercial\_GNBS and North\_Recreational selectivities are fixed in the hybrid selectivity model.

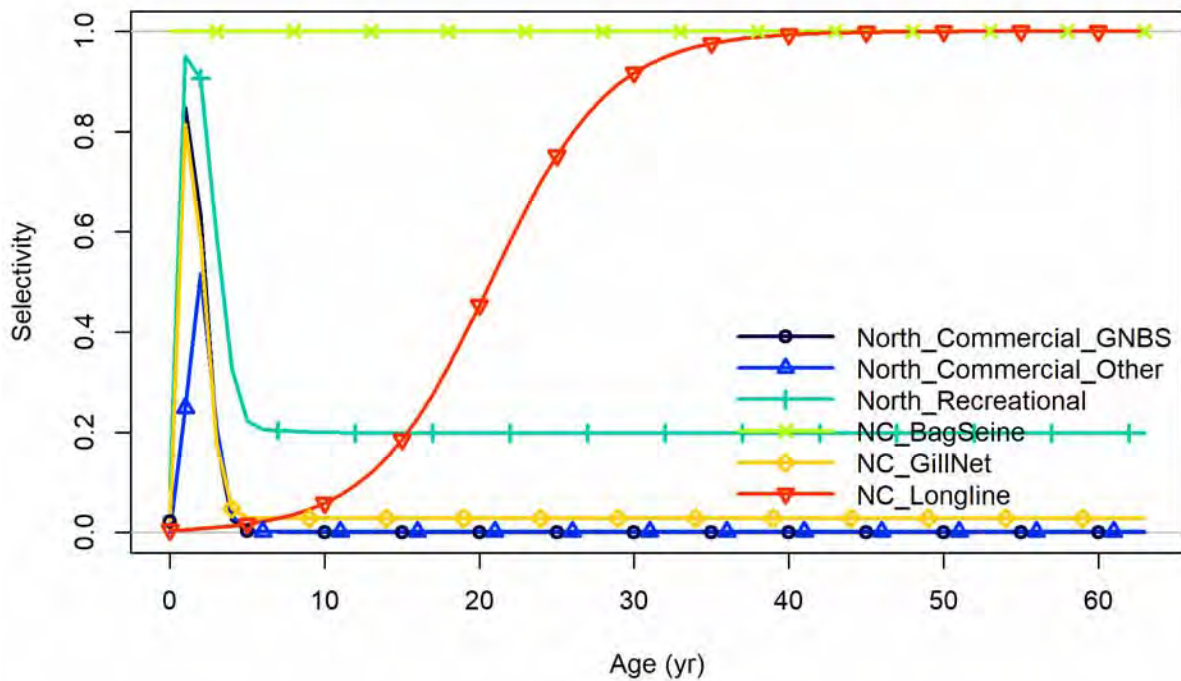
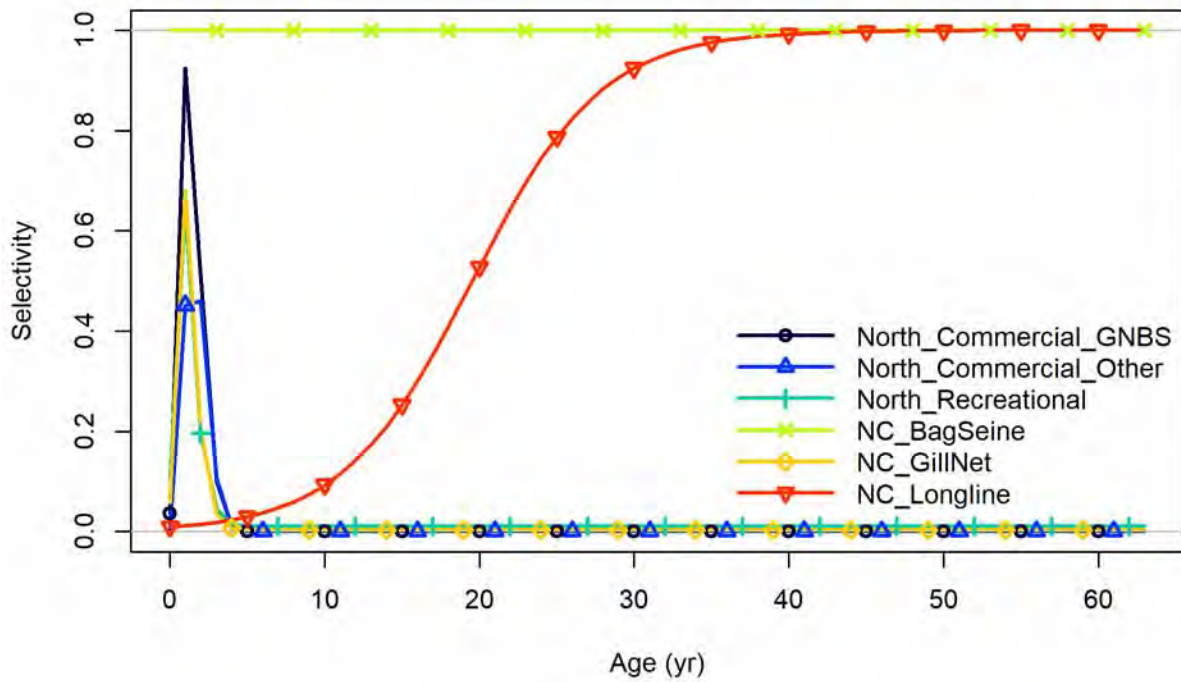
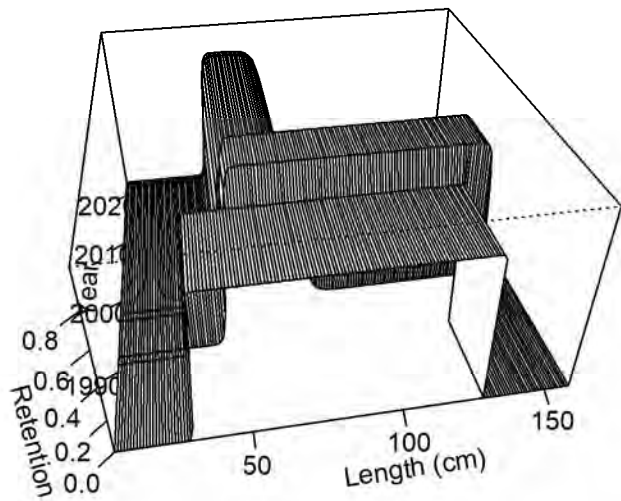
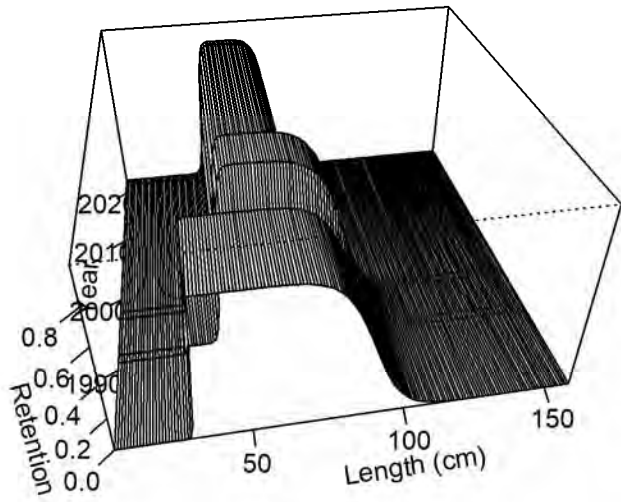
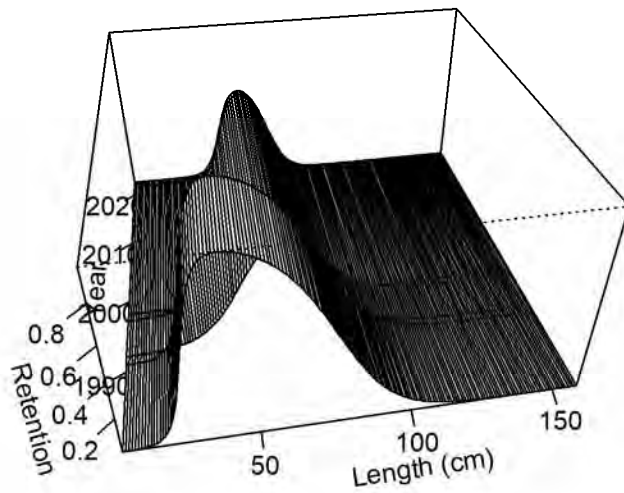
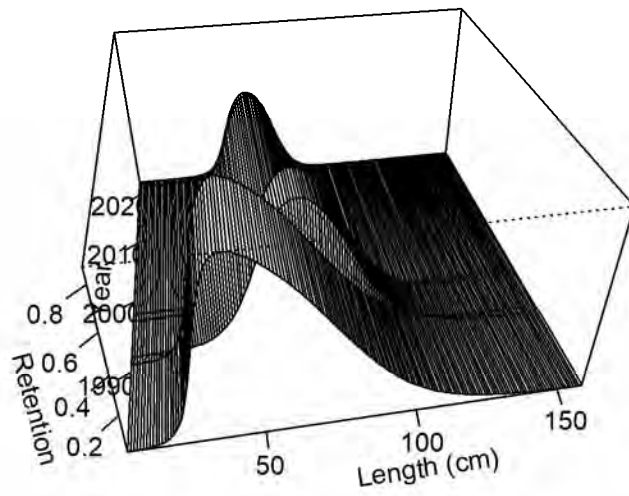


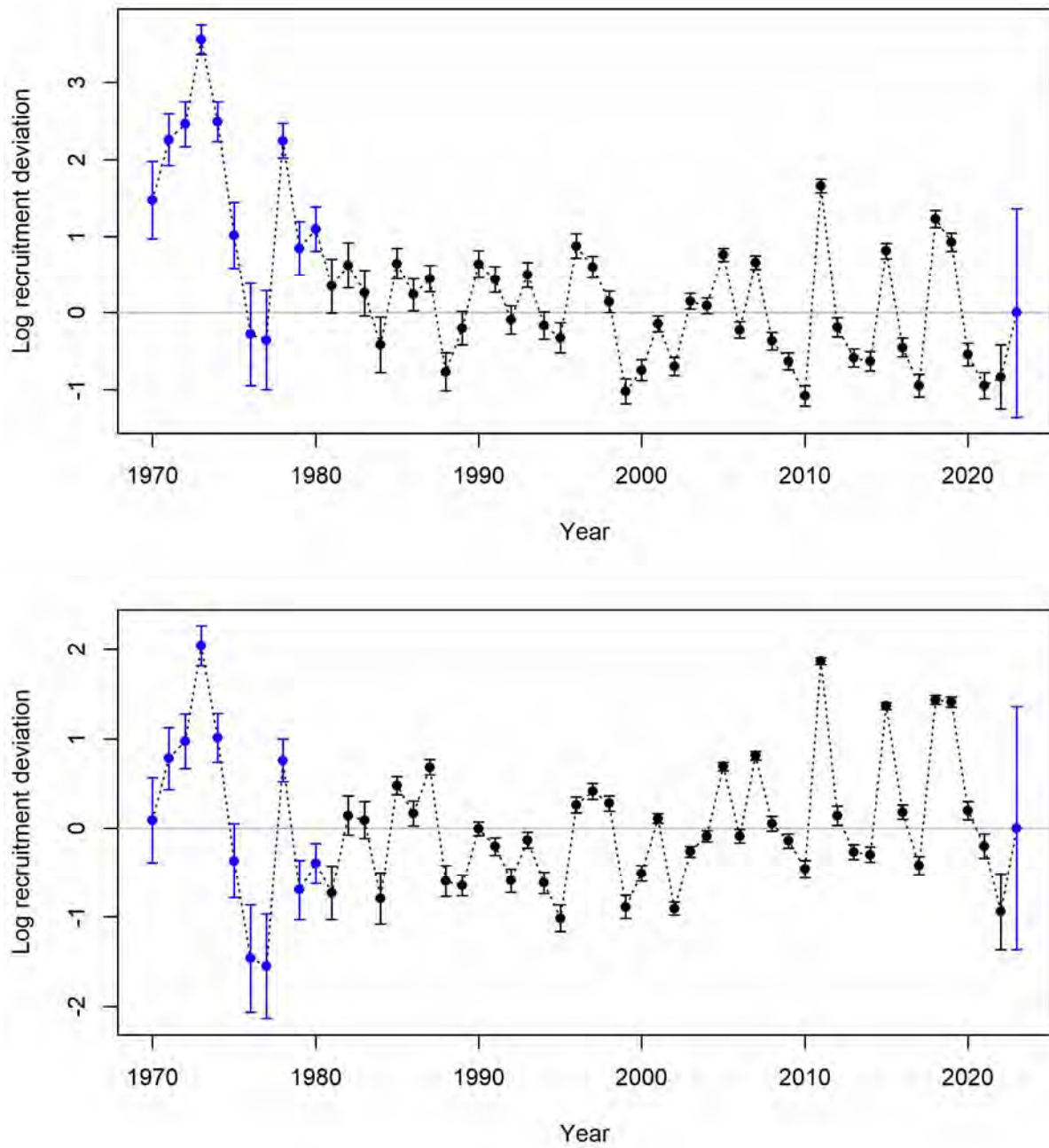
Figure 147. Estimated age based selectivity for the NC\_Longline survey with derived age based selectivities for the other fleets for the northern stock SS estimated selectivity model (top) and hybrid selectivity model (bottom).



**Figure 148. Retention estimates, by regulatory period, for the North\_Commercial\_GNBS fleet for the northern stock SS estimated selectivity model (top) and hybrid selectivity model (bottom).**

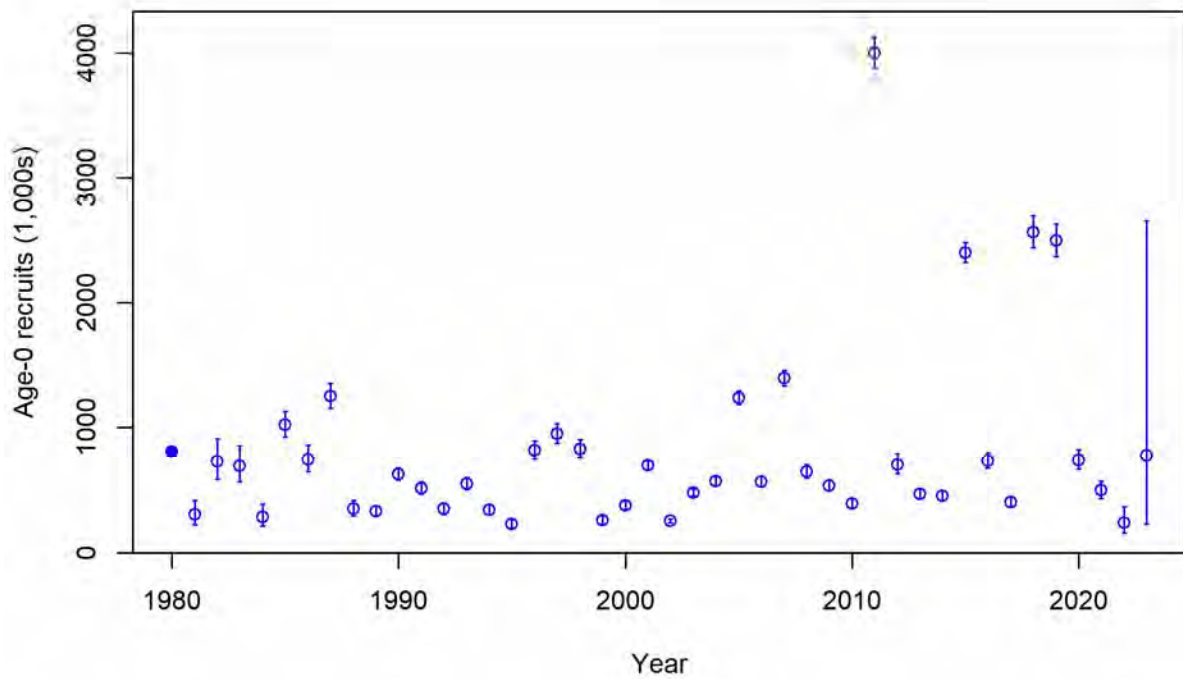
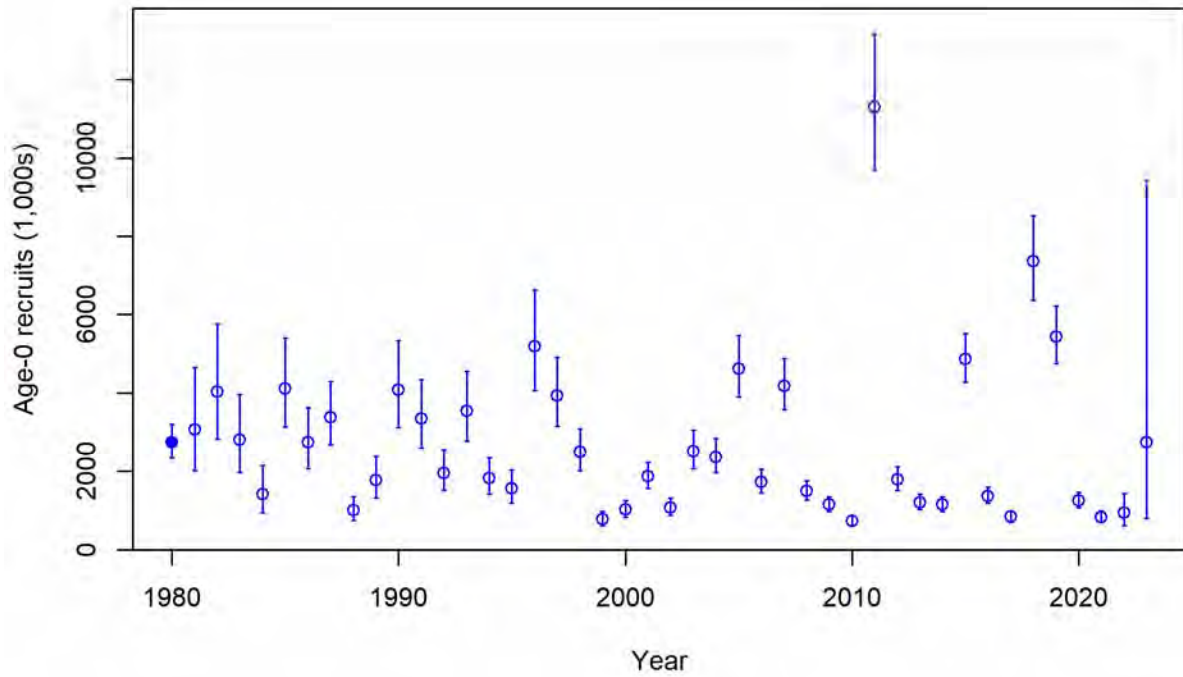


**Figure 149. Retention estimates, by regulatory period, for the North\_Recreational fleet for the northern stock SS estimated selectivity model (top) and hybrid selectivity model (bottom).**

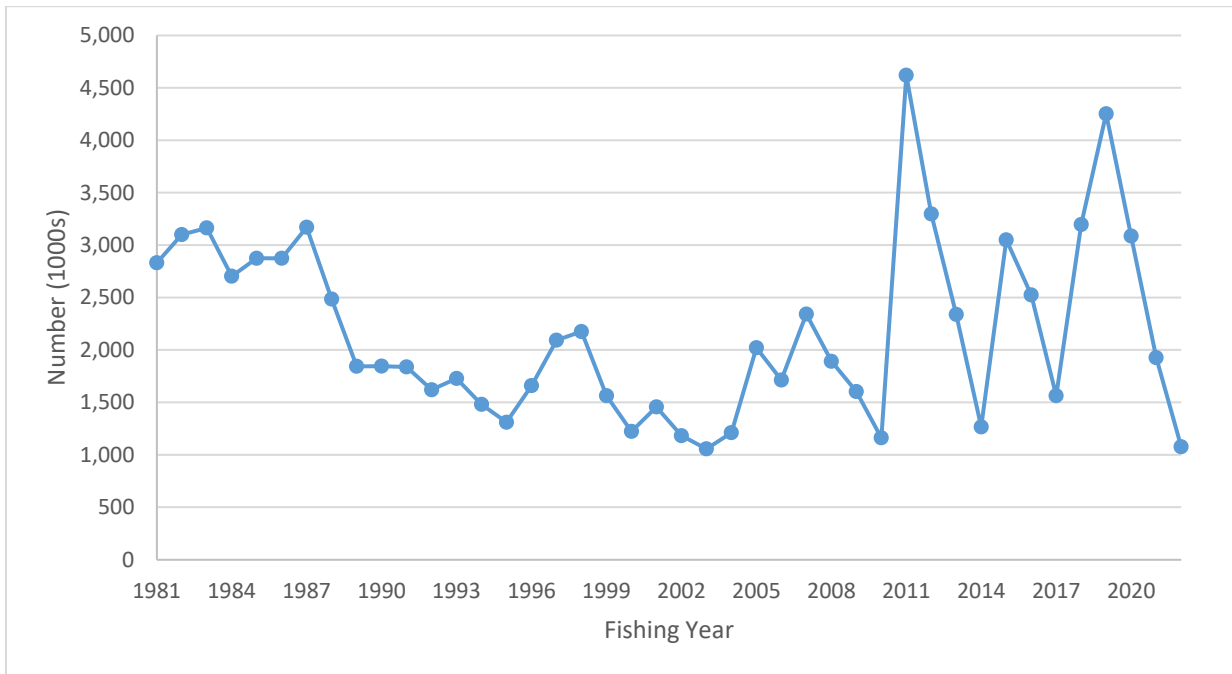
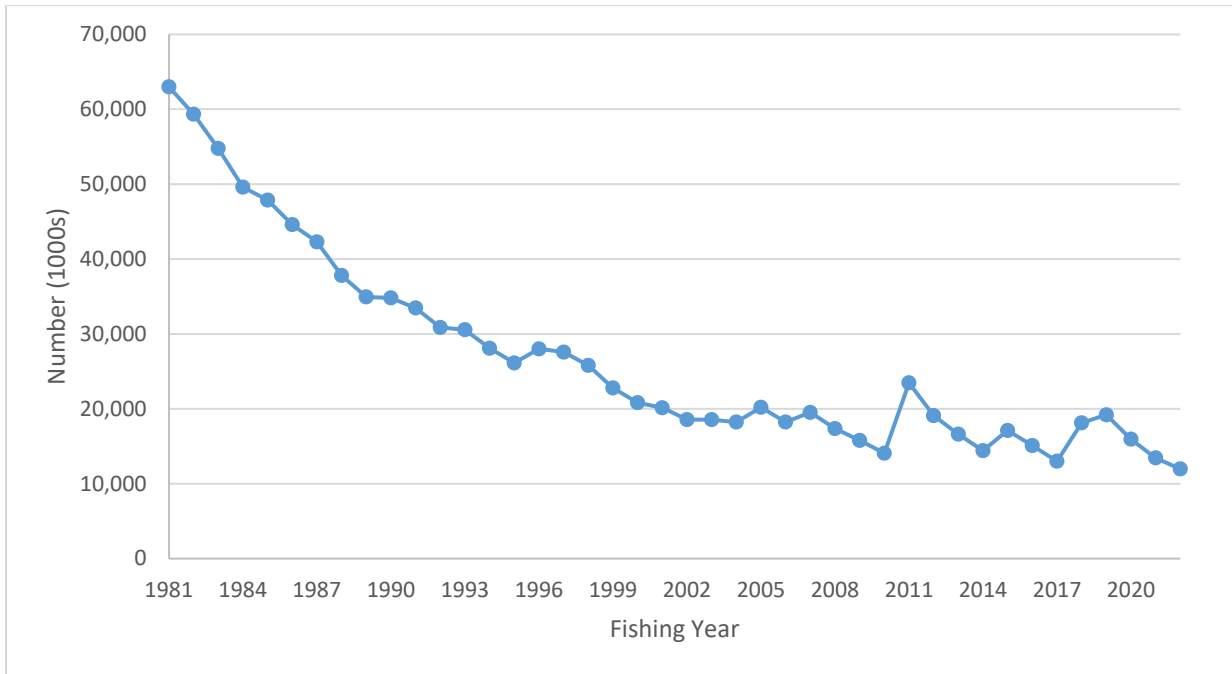


**Figure 150.** Recruitment deviations, with 95% confidence intervals from asymptotic standard errors, for the northern stock SS estimated selectivity model (top) and hybrid selectivity model (bottom).

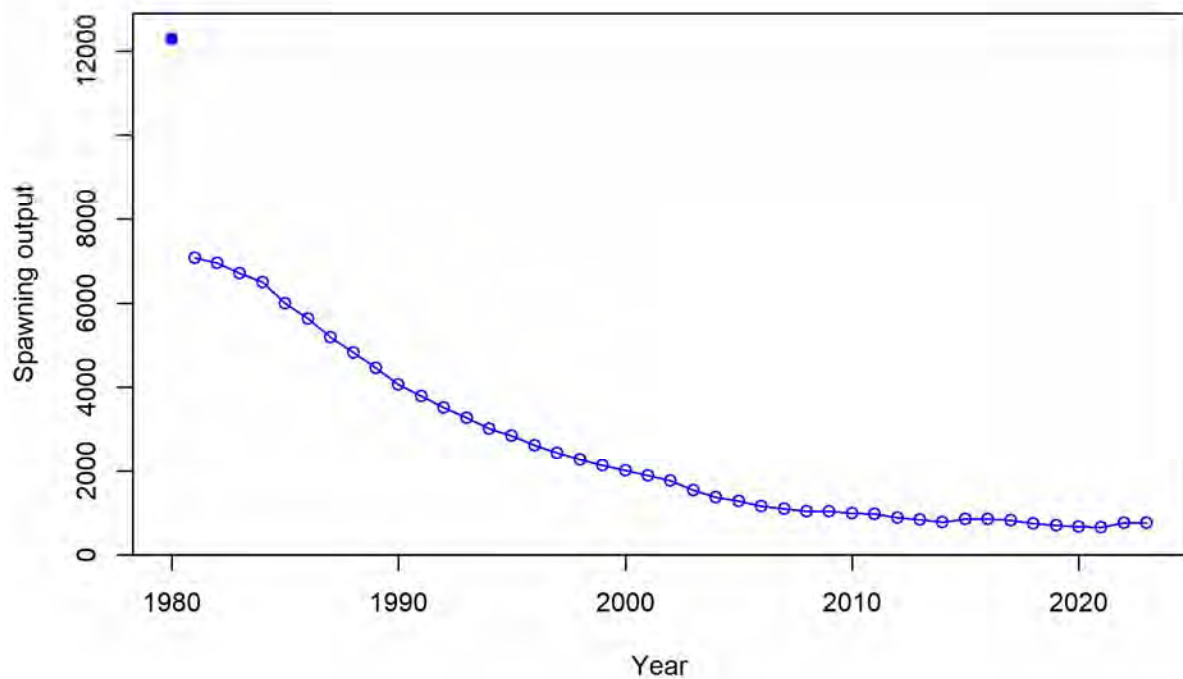
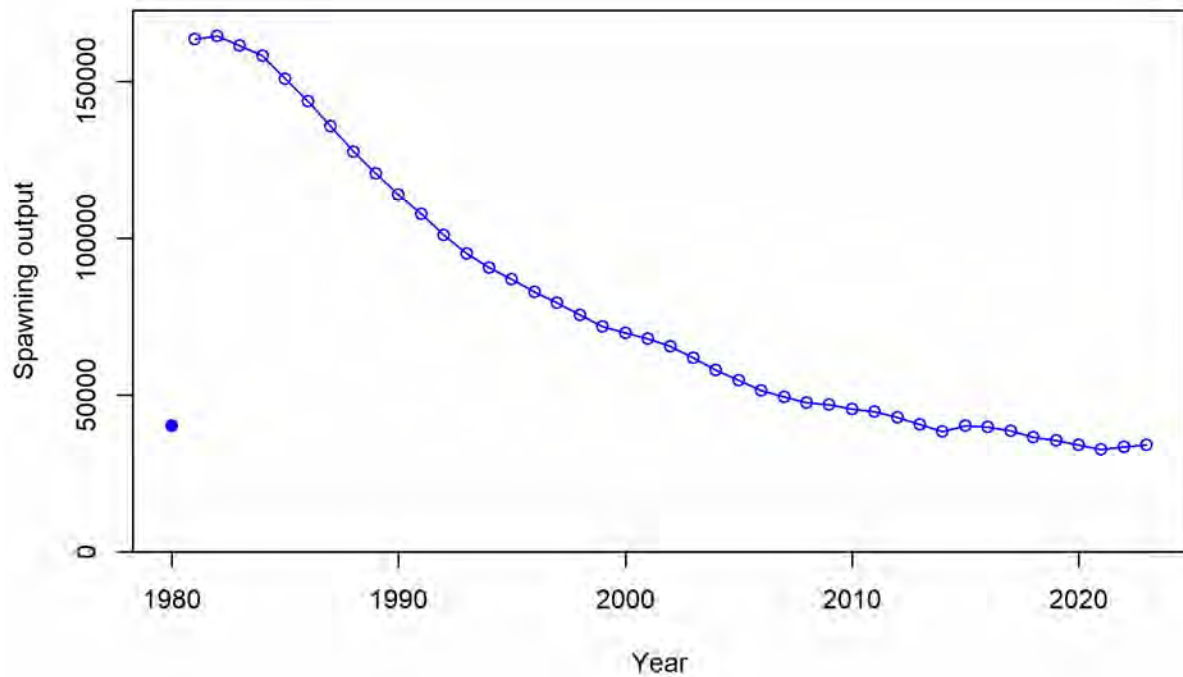




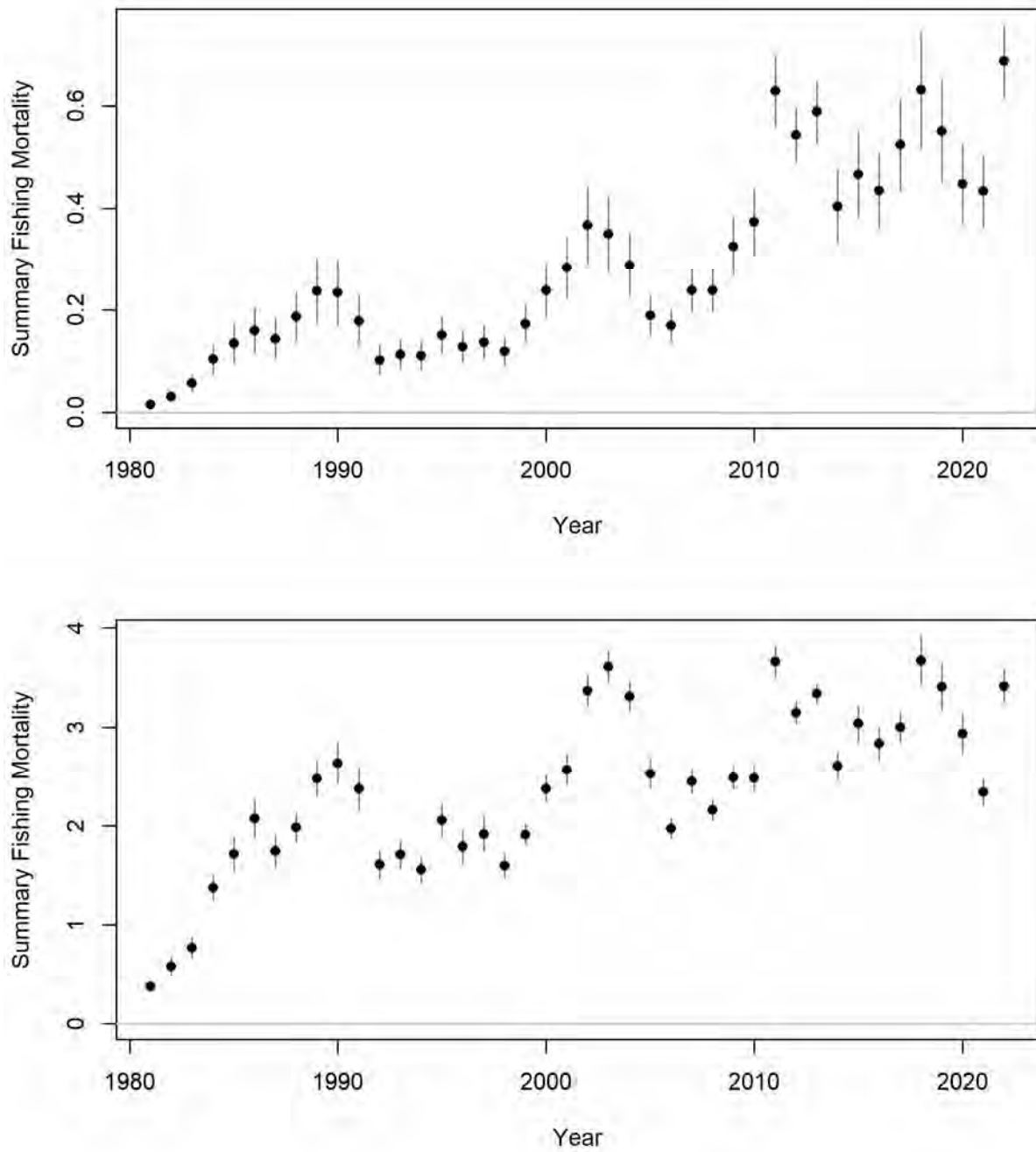
**Figure 151.** Estimated recruitment (in 1000s) for the northern stock SS estimated selectivity model (top) and hybrid selectivity model (bottom). Error bars are 95% confidence intervals based on asymptotic standard errors.



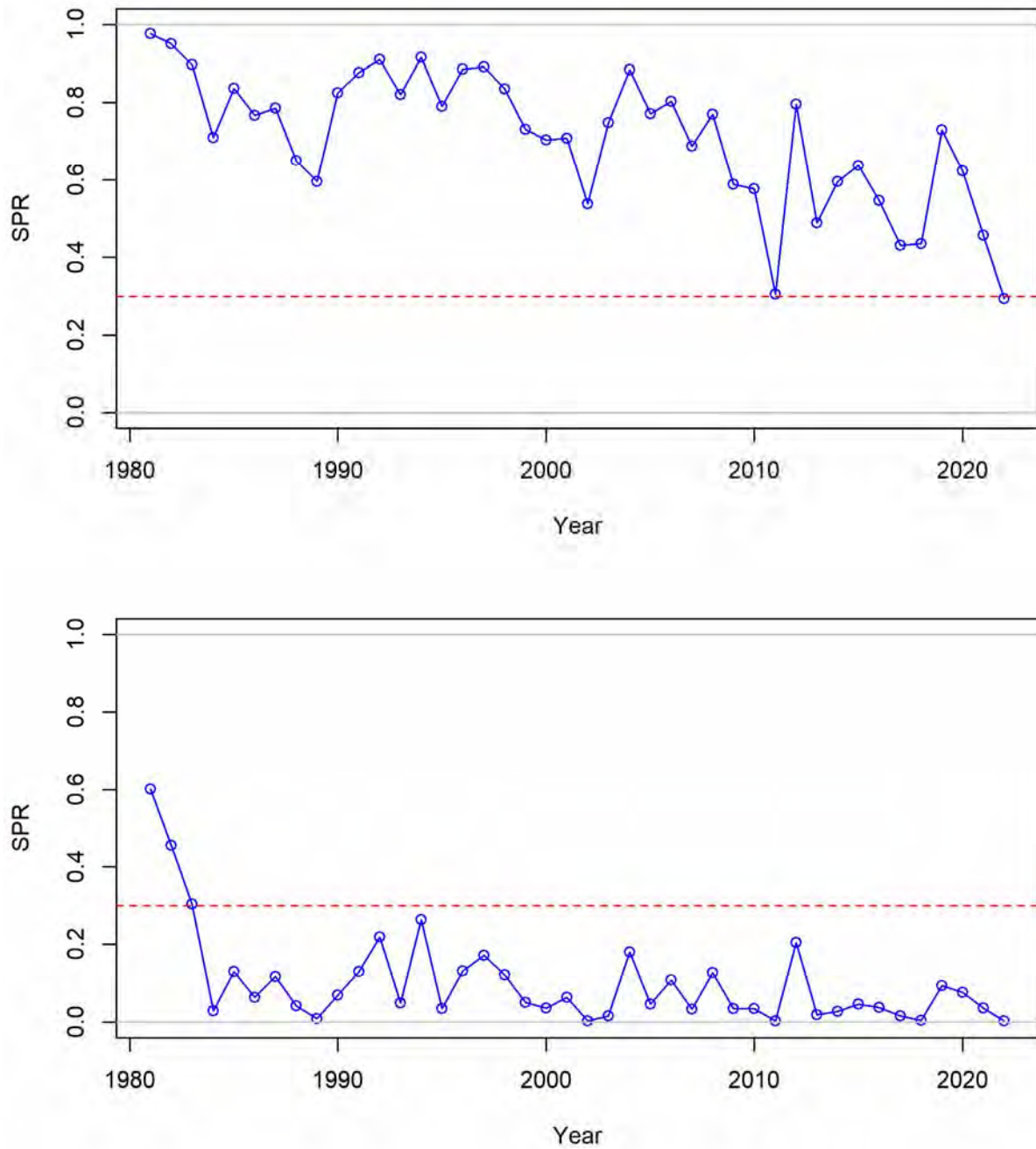
**Figure 152. Estimated population (in 1000s of fish) for the northern stock SS estimated selectivity model (top) and hybrid selectivity model (bottom).**



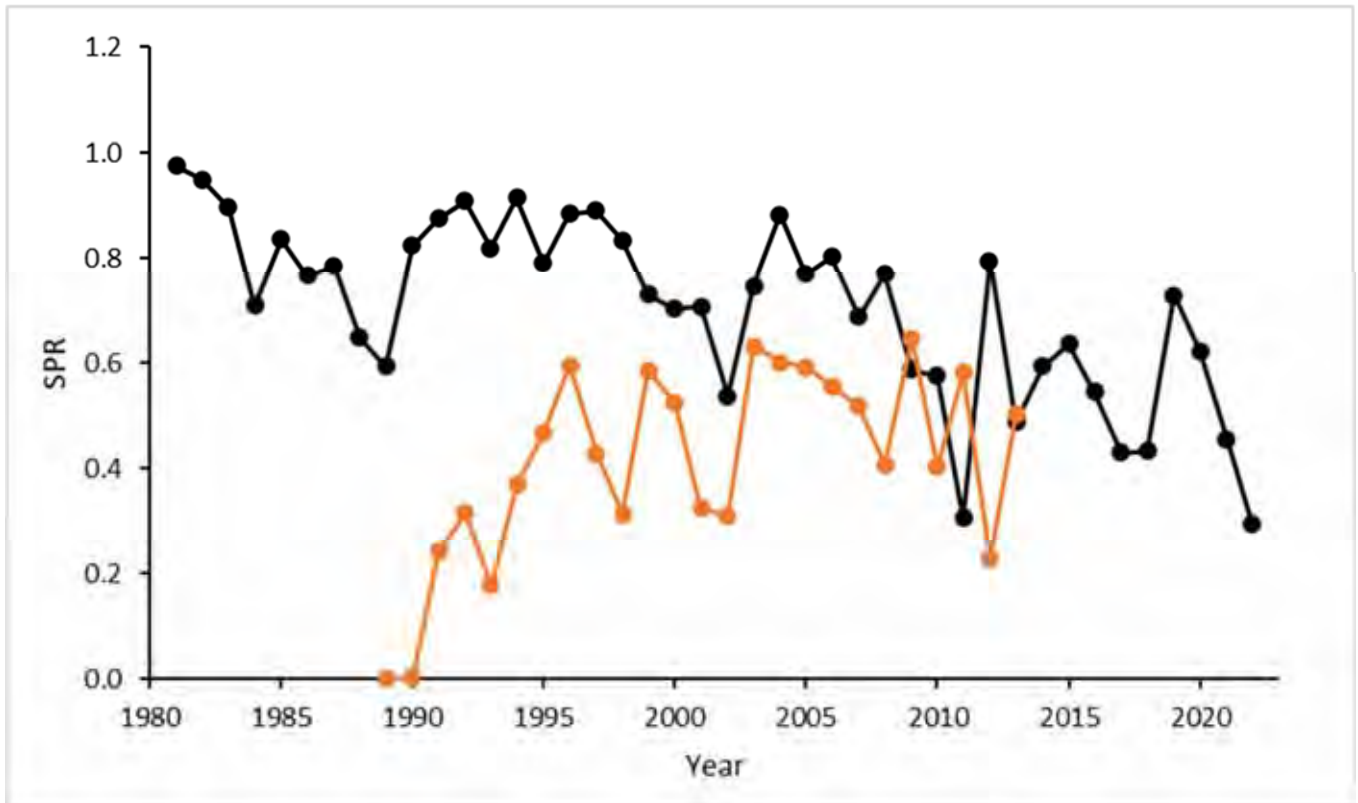
**Figure 153. Estimated female SSB (metric tons) for the northern stock SS estimated selectivity model (top) and hybrid selectivity model (bottom).**



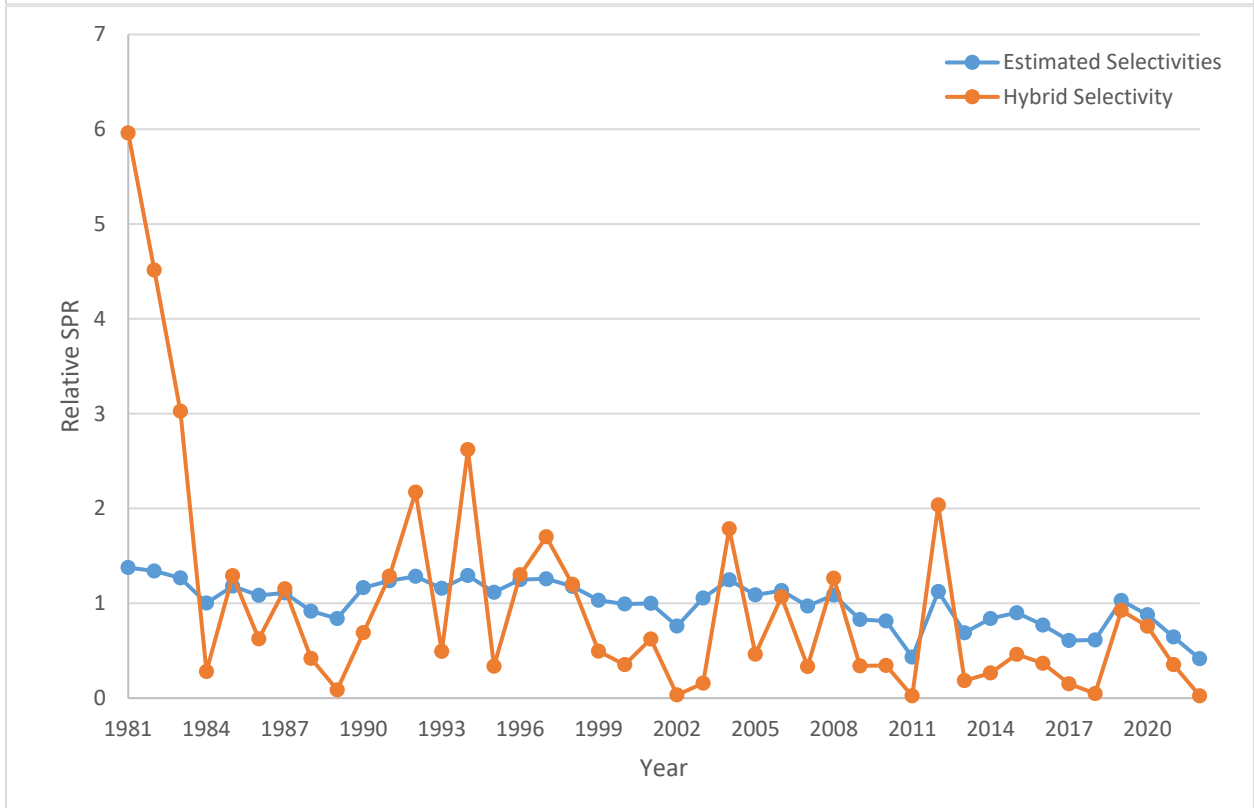
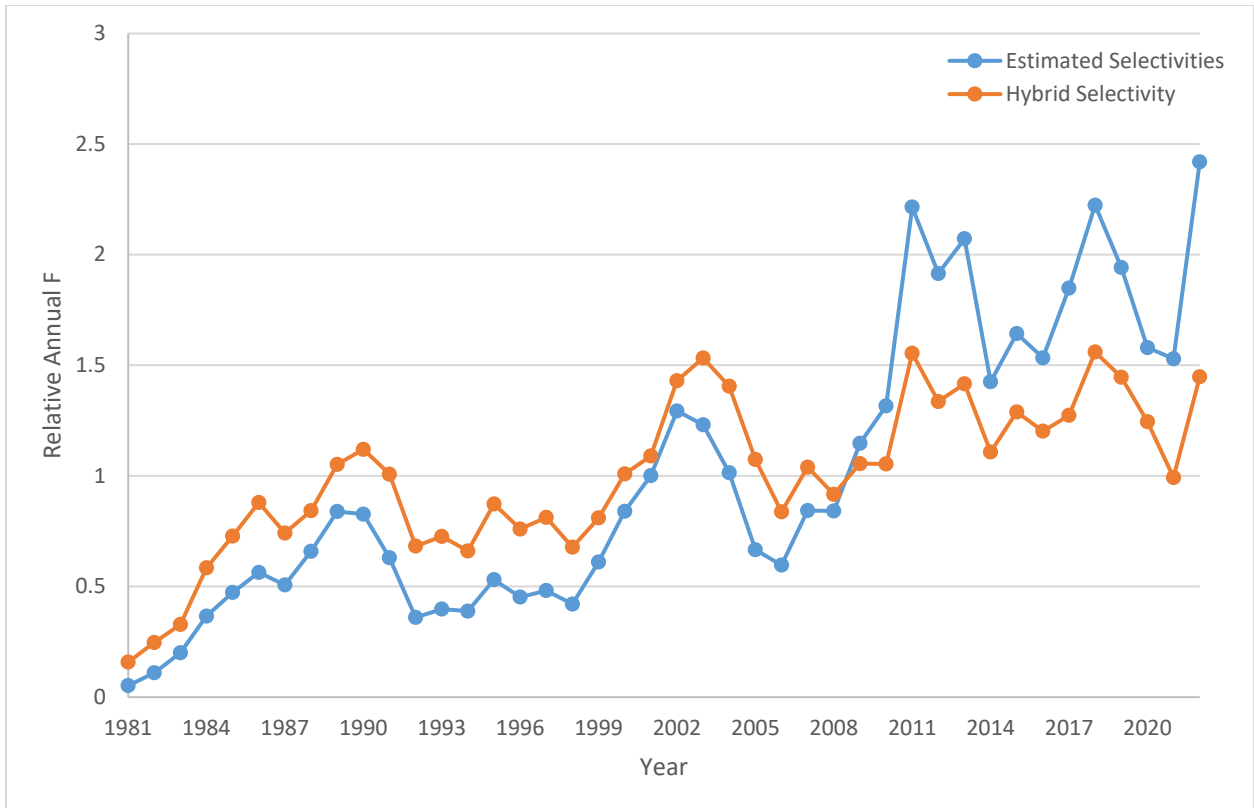
**Figure 154.** Total age-2 fishing mortality (F) for the northern stock SS estimated selectivity model (top) and hybrid selectivity model (bottom). Error bars are 95% confidence intervals based on asymptotic standard errors.



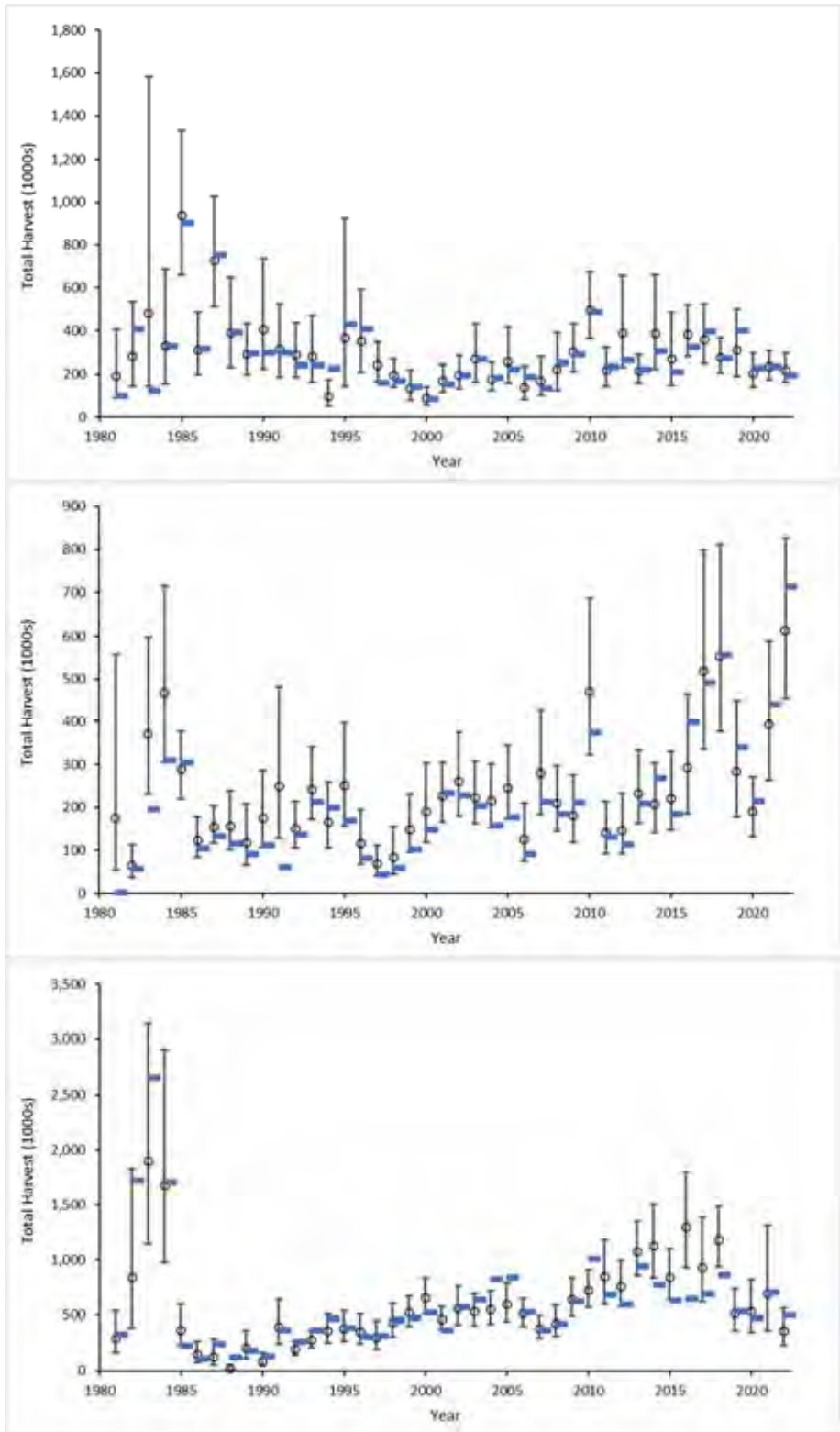
**Figure 155. SPR timeseries for the northern stock SS estimated selectivity model (top) and hybrid selectivity model (bottom). Horizontal line is the SPR target (0.30).**



**Figure 156.** Spawning potential ratio estimates for the northern stock from the previous benchmark stock assessment using a custom statistical catch-at-age model (ASMFC 2017; orange) and the current benchmark assessment SS estimated selectivity model (black). Estimates from the previous assessment are for calendar years while estimates in the current assessment are for fishing years.

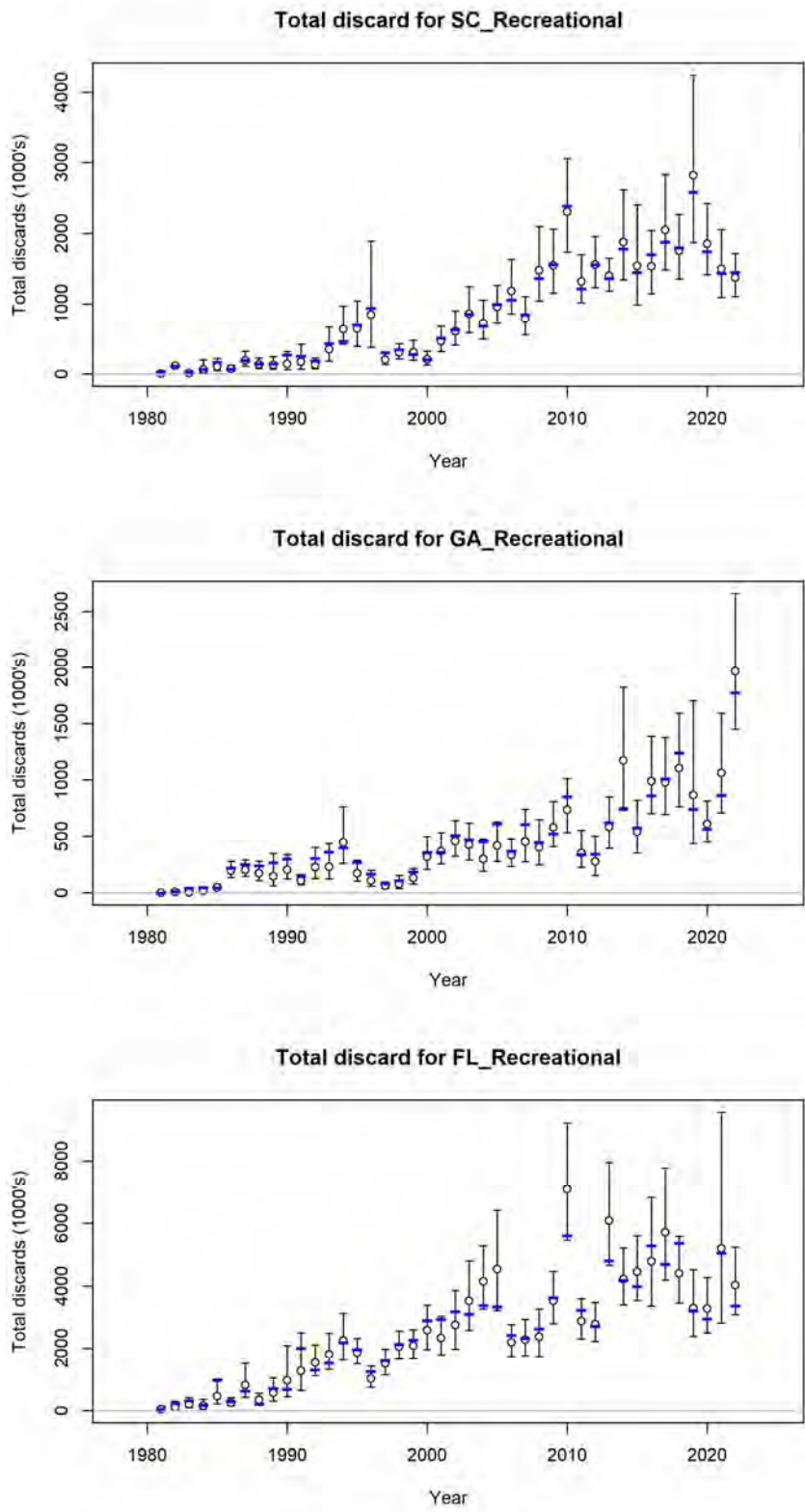


**Figure 157. F and SPR timeseries for the northern stock SS hybrid and estimated selectivity models, each scaled to their means.**

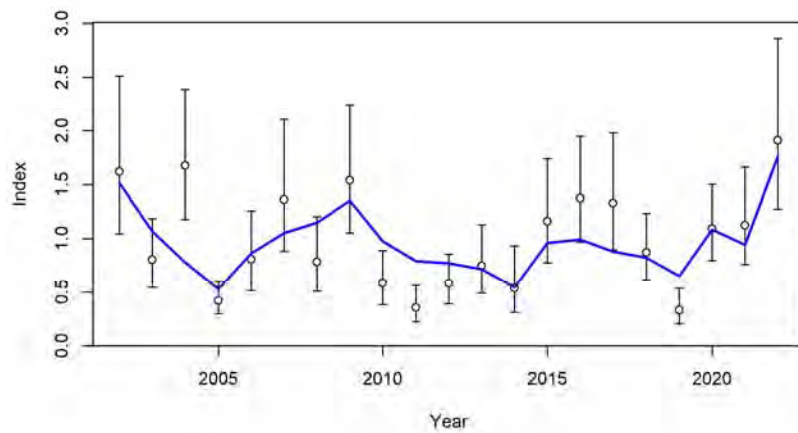
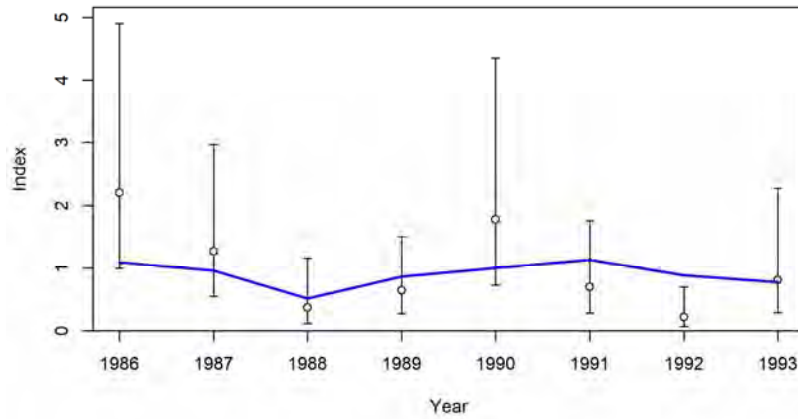
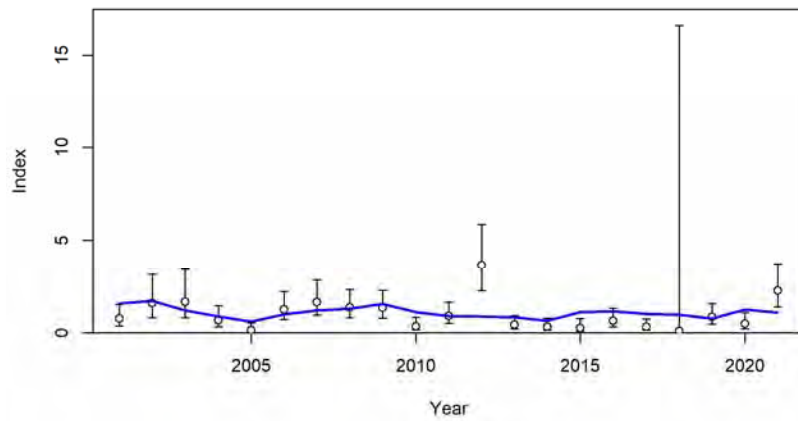


**Figure 158. Observed and estimated catches for the SC\_Recreational (top), GA\_Recreational (middle), and FL\_Recreational (bottom) fleets for the southern stock SS base model.**

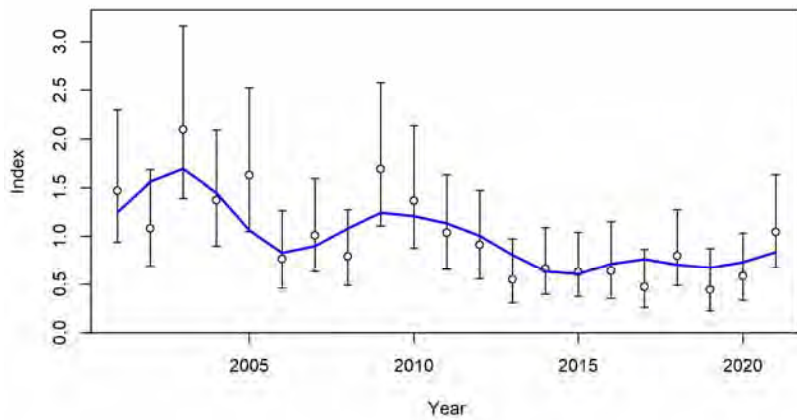
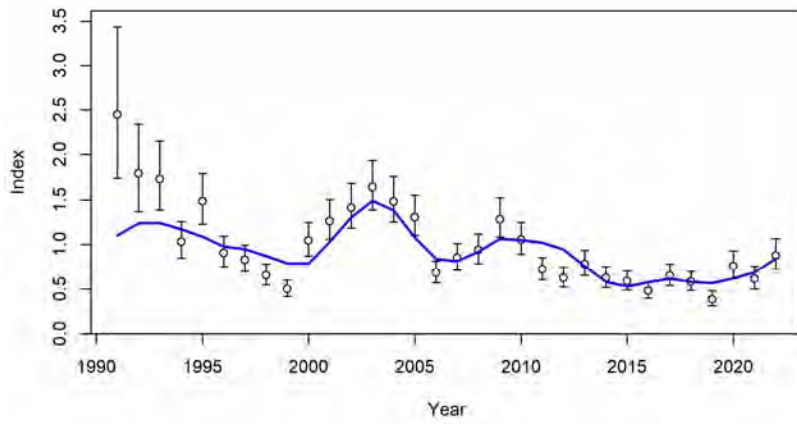
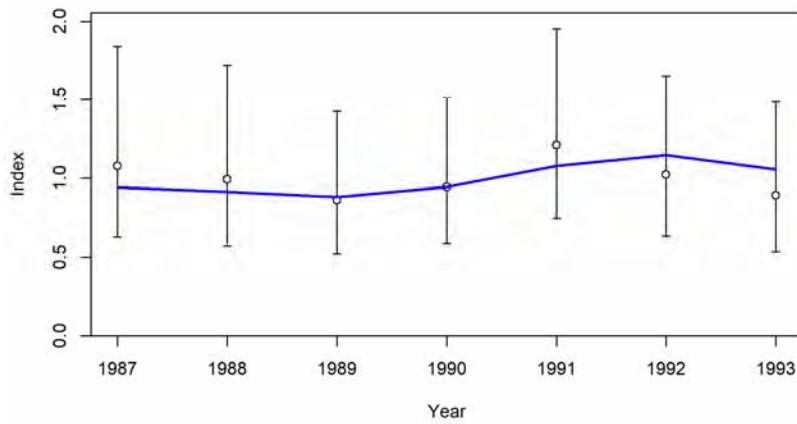




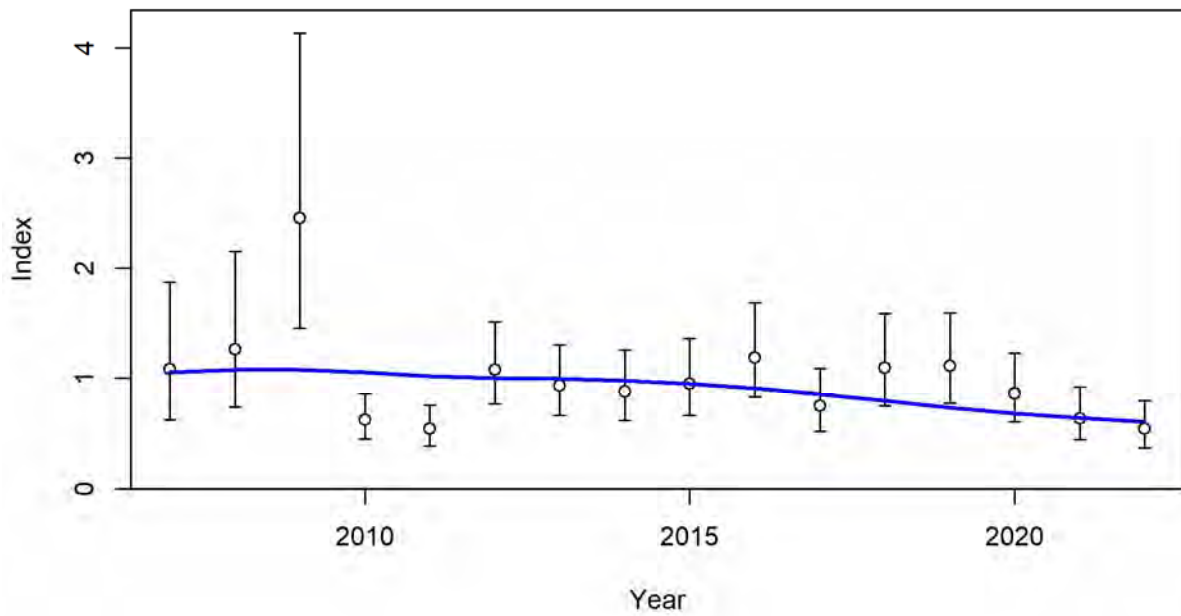
**Figure 159. Observed and estimated discards (in 1000's of fish) for the southern stock SS base model.**



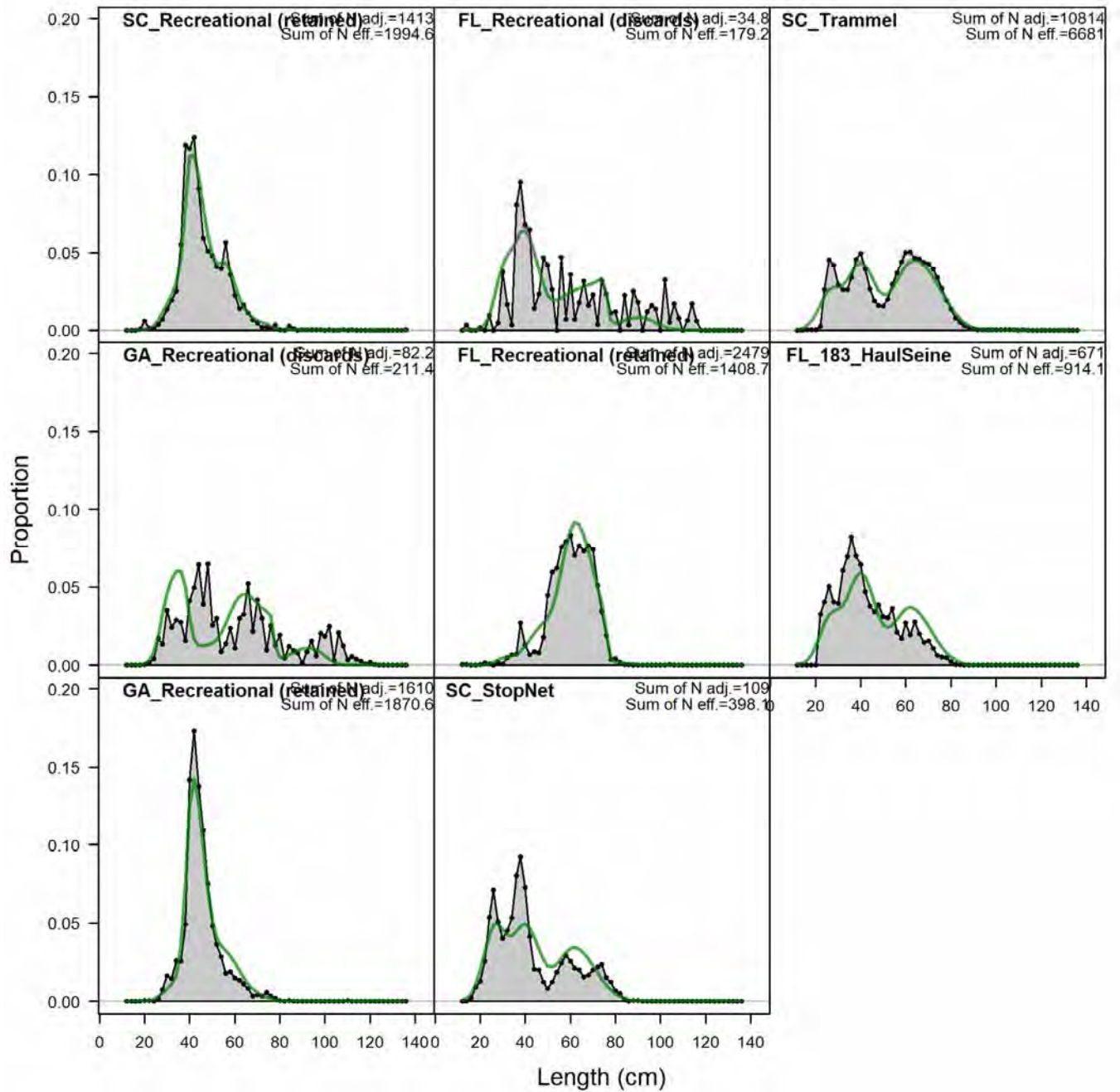
**Figure 160.** Observed and estimated index values for the FL\_21.3\_HaulSeine (top), SC\_Rotenone (middle), and GA\_GillNet (bottom) age-0 recruitment surveys for the southern stock SS base model.



**Figure 161.** Observed and estimated index values for the SC\_StopNet (top), SC\_Trammel (middle), and FL\_183\_HaulSeine (bottom) sub-adult surveys for the southern stock SS base model.



**Figure 162. Observed and estimated index values for the adult longline survey for the southern stock SS base model.**



**Figure 163.** Length compositions, aggregated across time by fleet/survey for the southern stock SS base model.

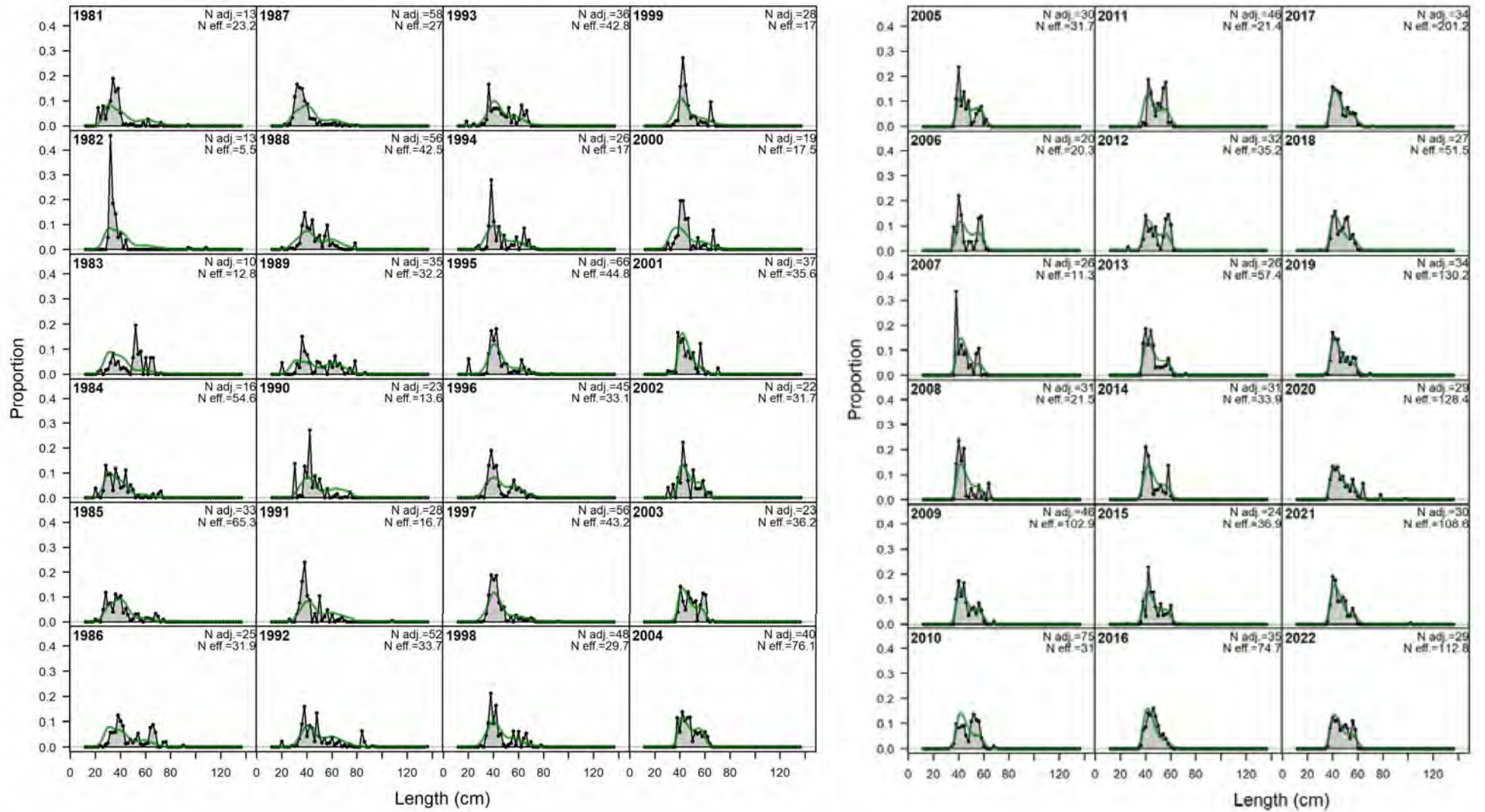
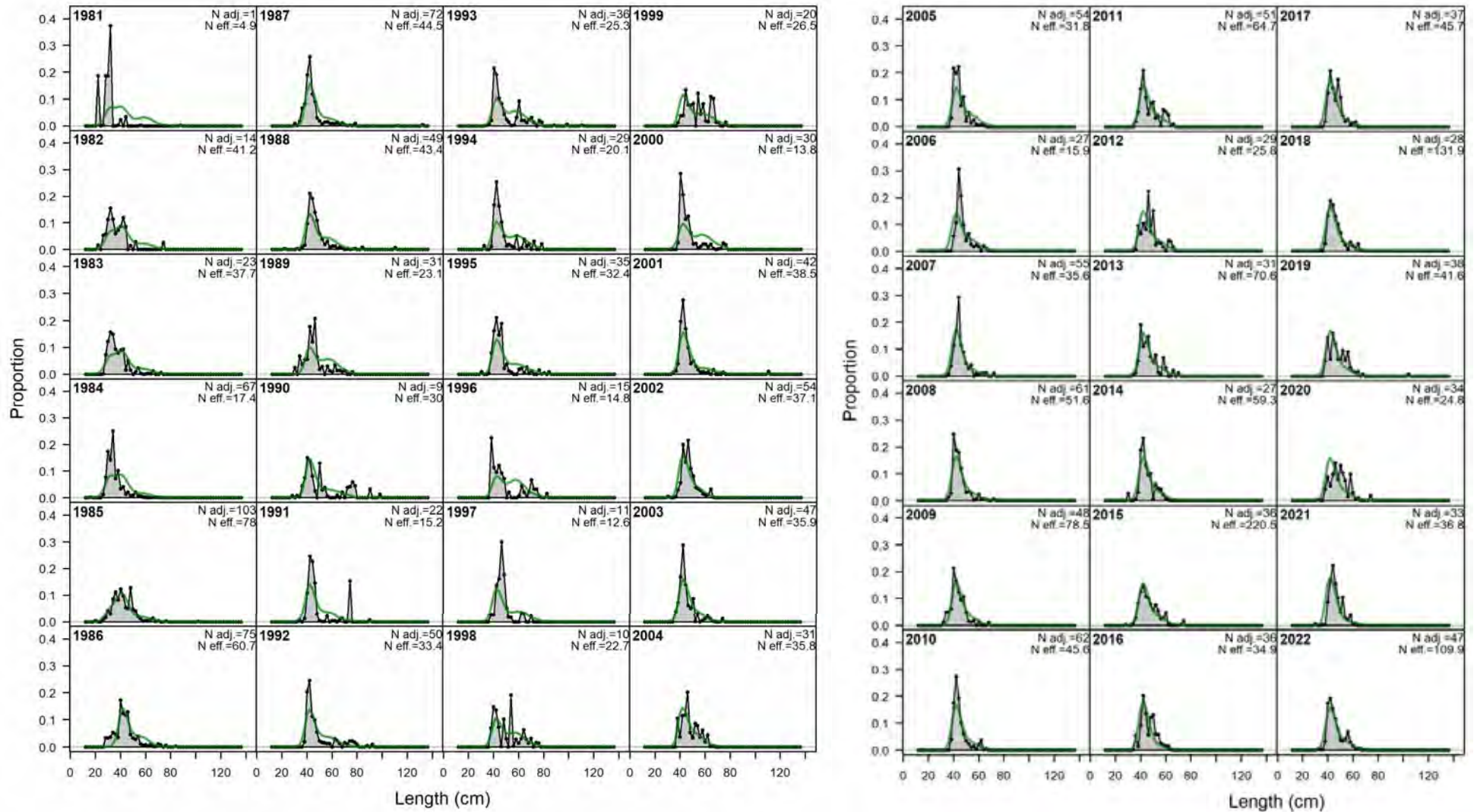
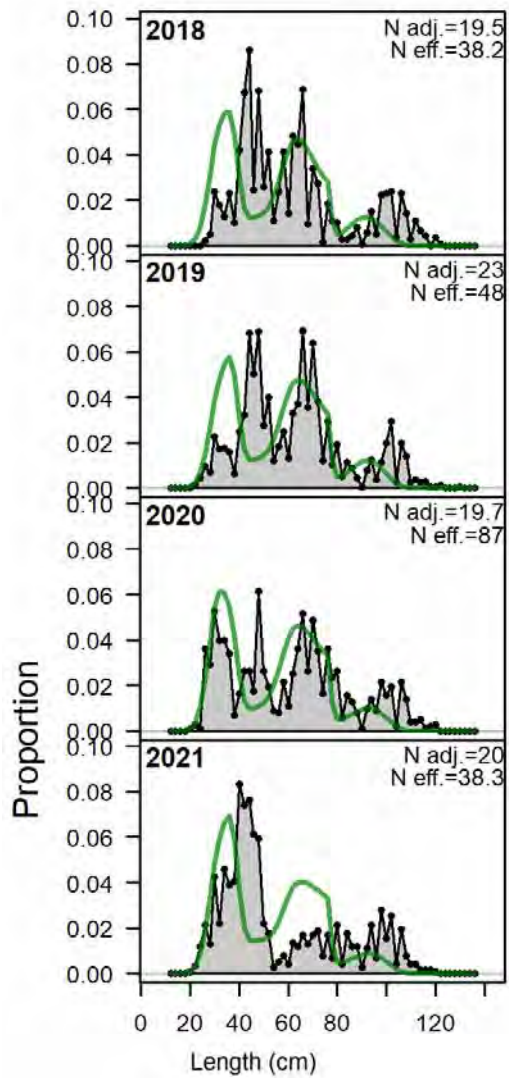


Figure 164. Annual length compositions for the SC\_Recreational fleet retained catch for the southern stock SS base model.



**Figure 165. Annual length compositions for the GA\_Recreational fleet retained catch for the southern stock SS base model.**



**Figure 166.** Annual length compositions for the GA\_Recreational fleet discards for the southern stock SS base model.



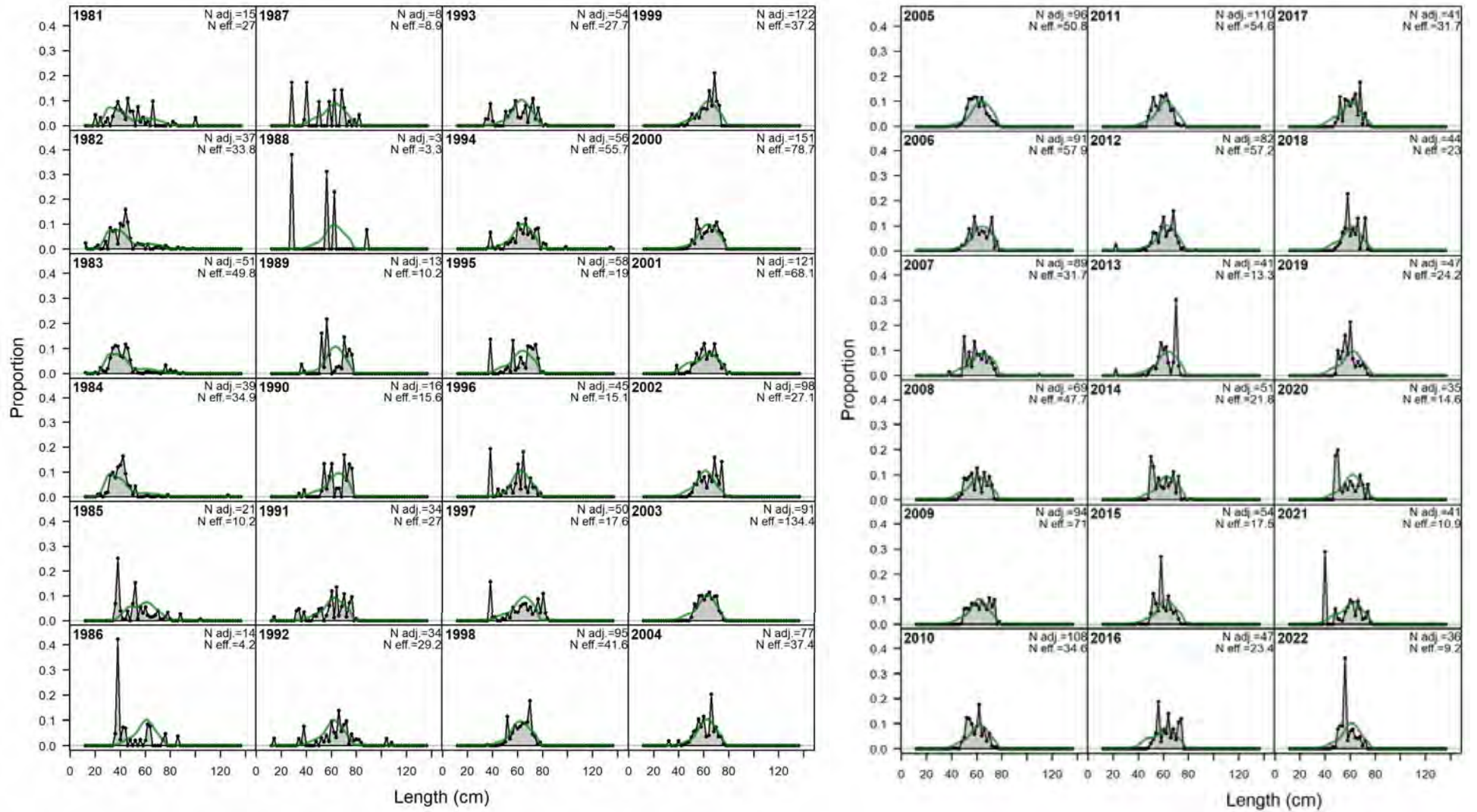
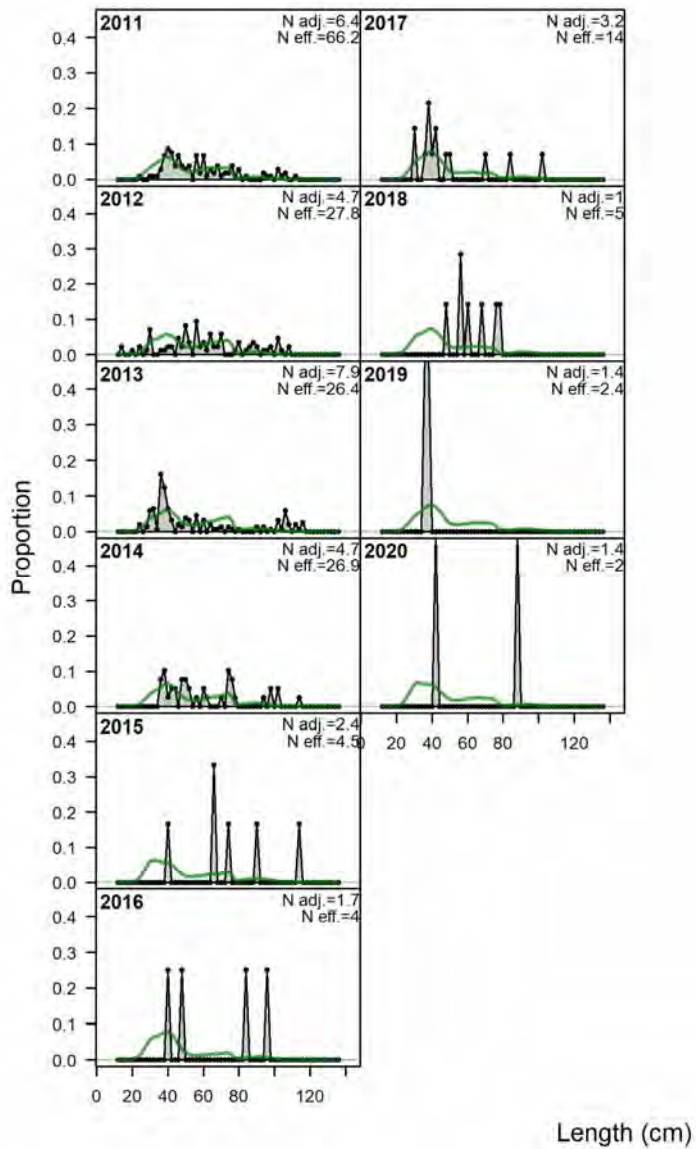
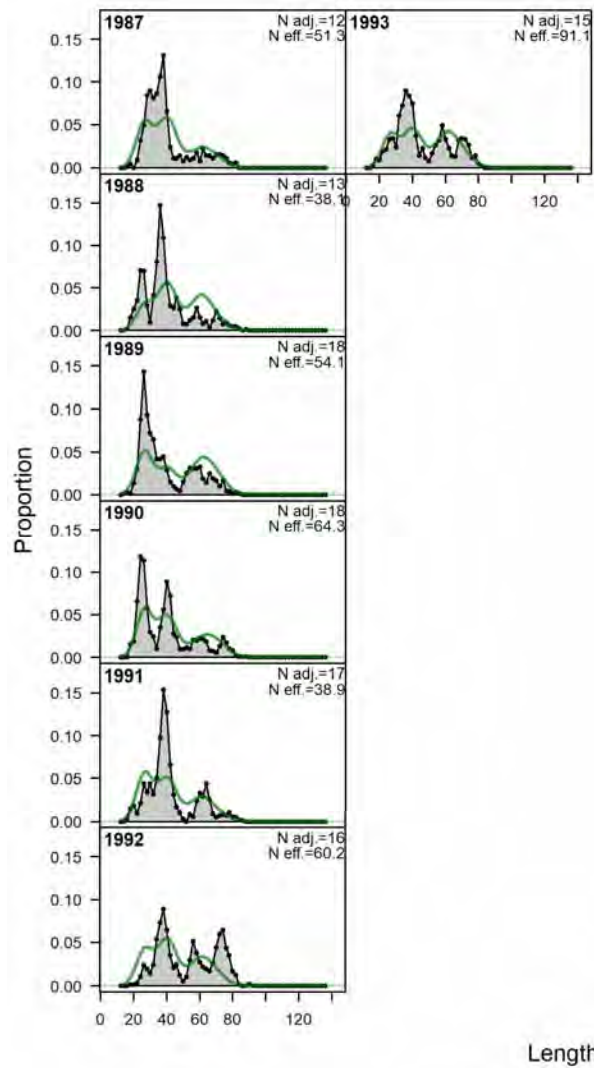


Figure 167. Annual length compositions for the FL\_Recreational fleet retained catch for the southern stock SS base model.



**Figure 168.** Annual length compositions for the FL\_Recreational fleet discards for the southern stock SS base model.



**Figure 169.** Annual length compositions for the SC\_StopNet survey for the southern stock SS base model.

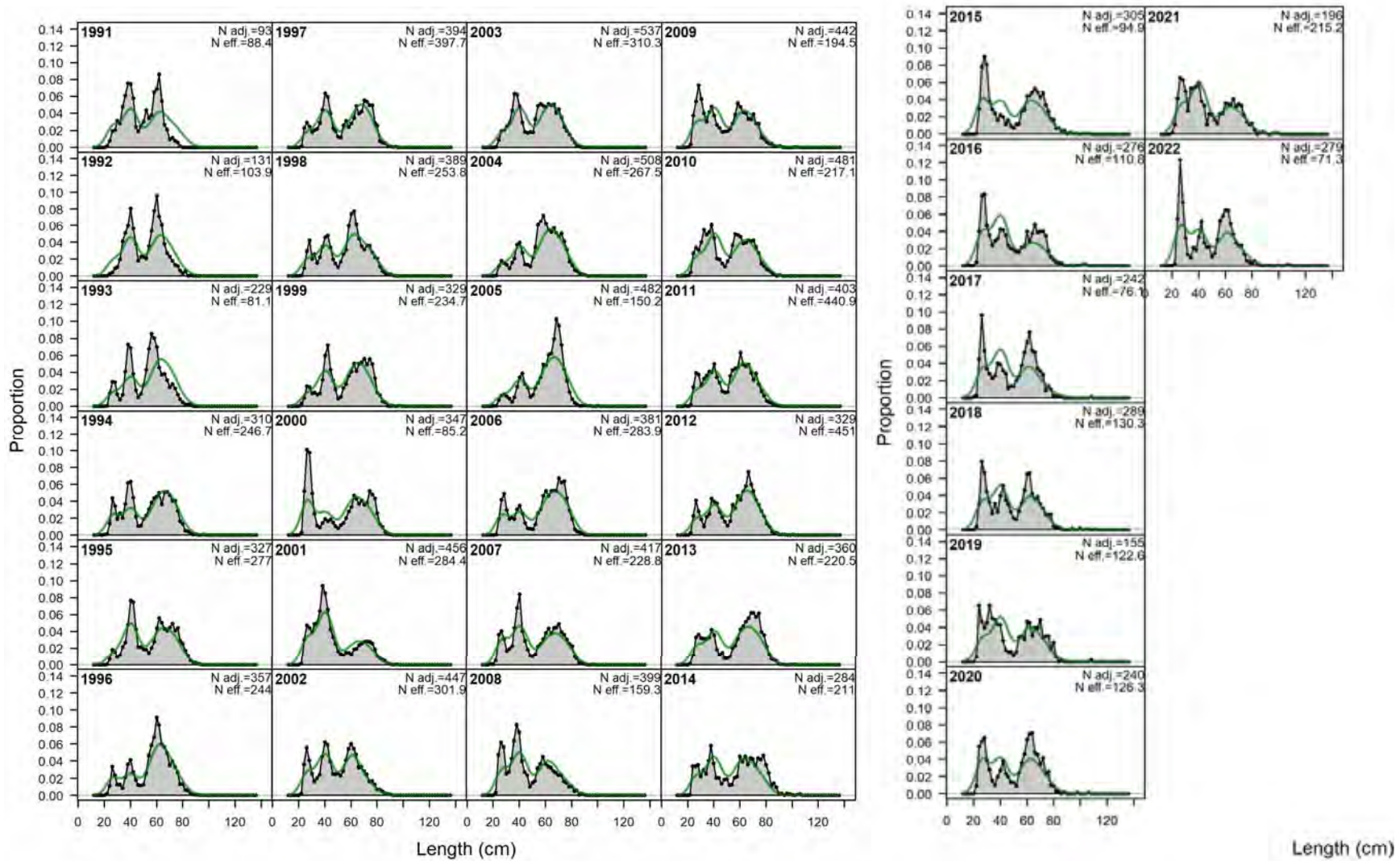
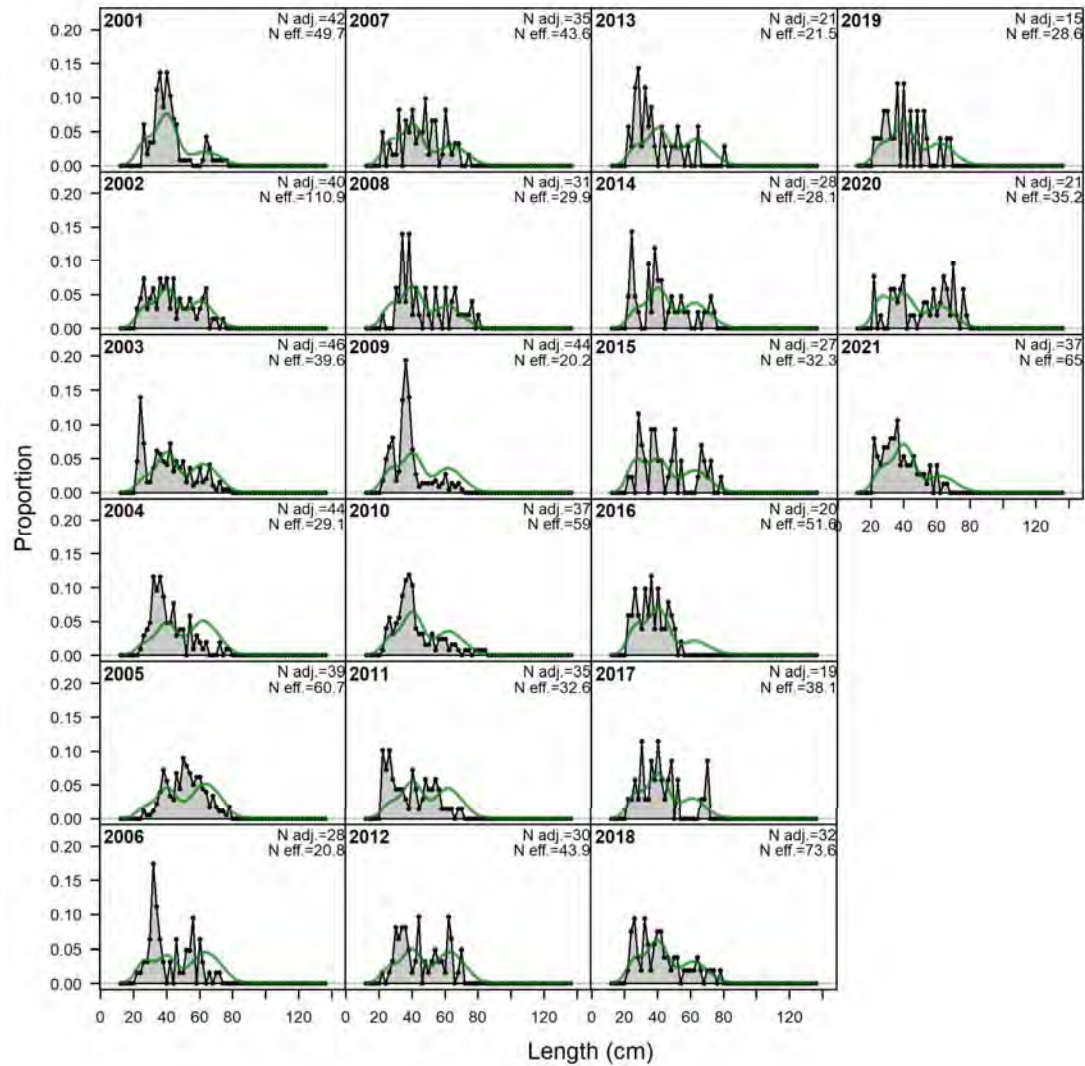
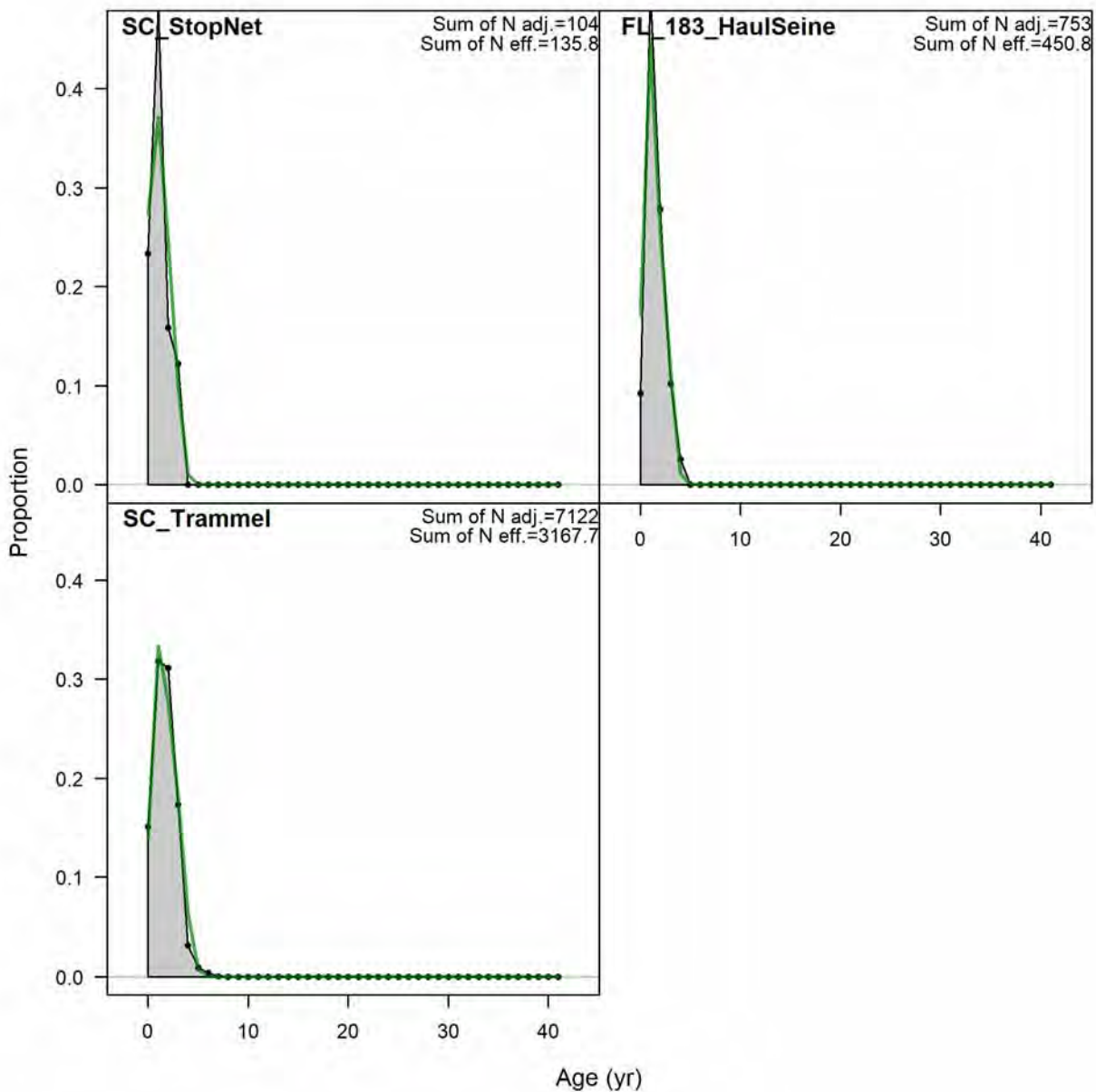


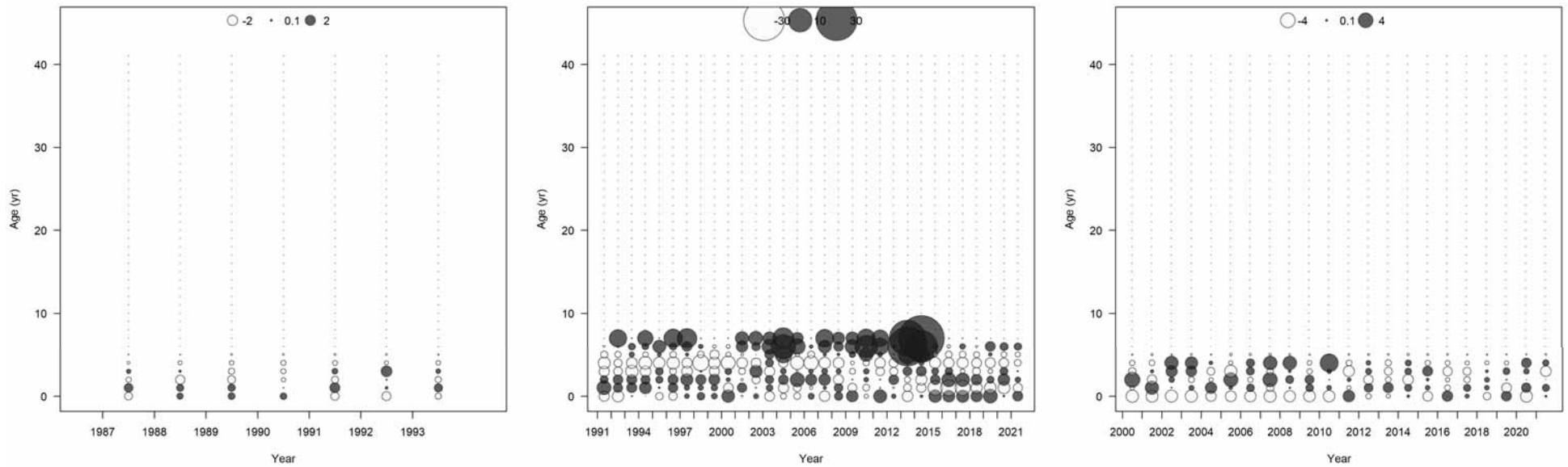
Figure 170. Annual length compositions for the SC\_Trammel survey for the southern stock SS base model.



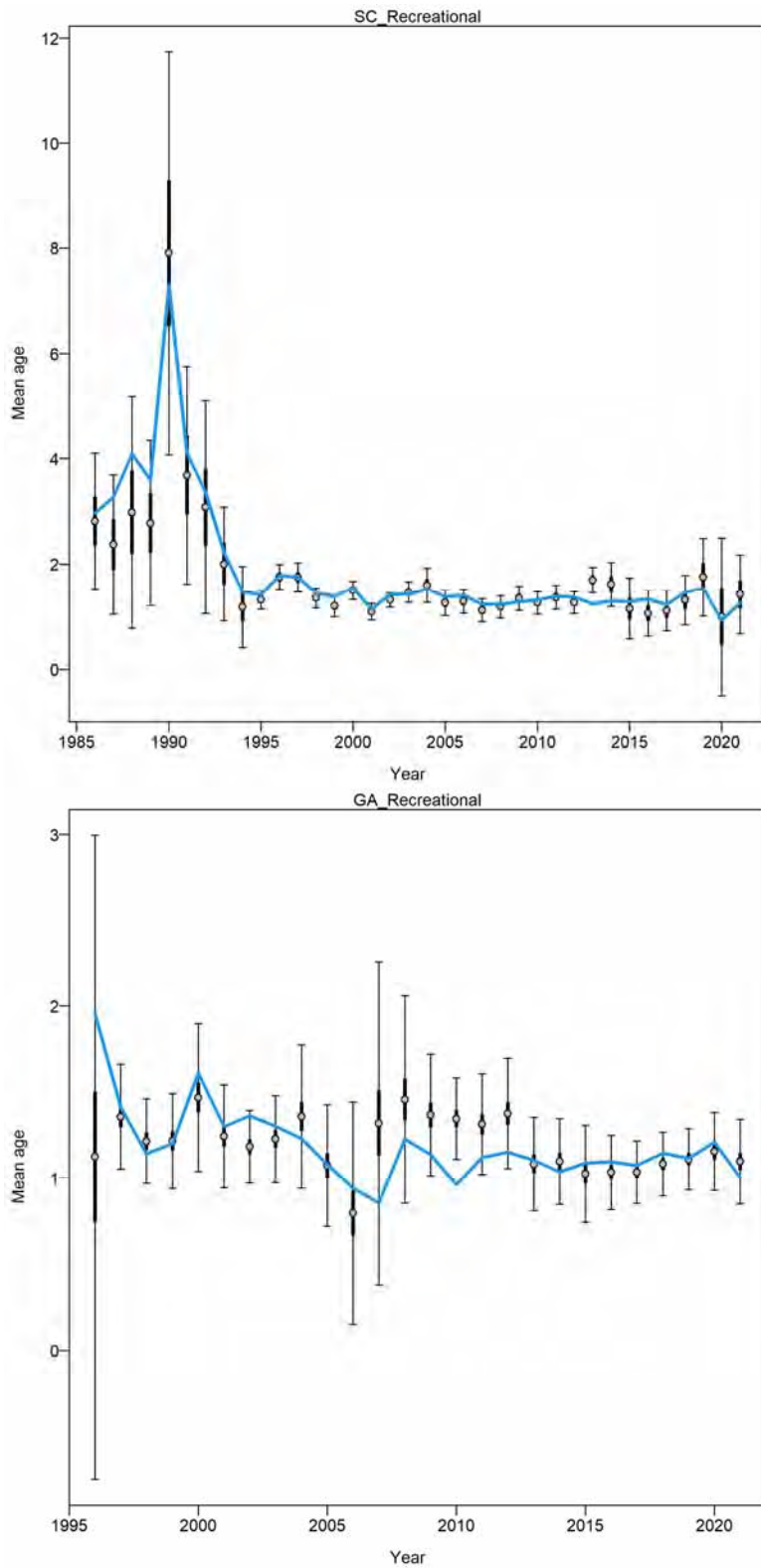
**Figure 171. Annual length compositions for the FL\_183\_HaulSeine survey for the southern stock SS base model.**



**Figure 172.** Age compositions, aggregated across time by survey for the southern stock SS base model.

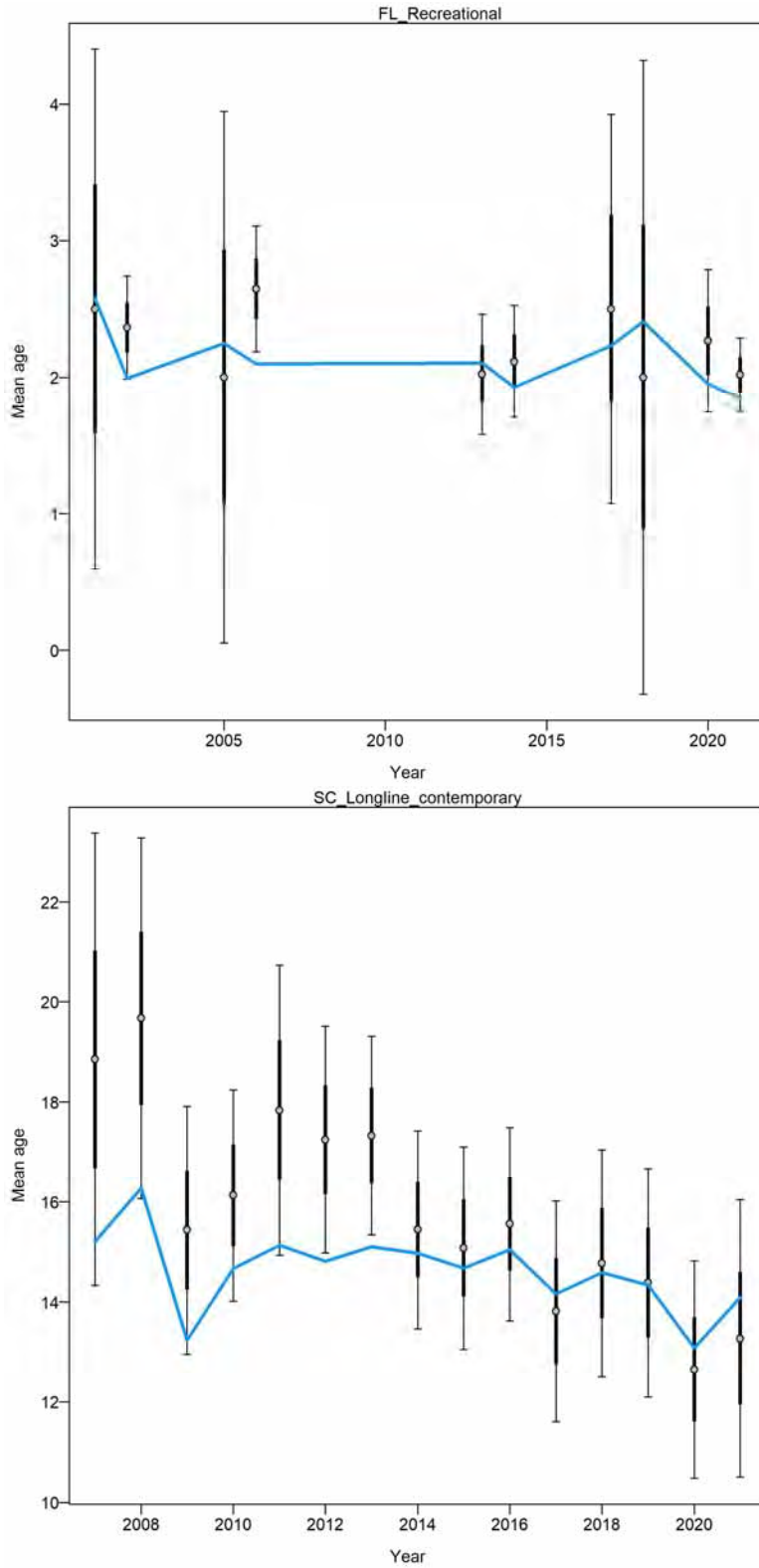


**Figure 173. Annual age compositions for the SC\_StopNet (left), SC\_Trammel (middle), and FL\_183\_HaulSeine (right) surveys for the southern stock SS base model.**



**Figure 174.** Mean age from the conditional age data for the SC\_Recreational (top) and GA\_Recreational (bottom) fleets for the southern stock SS base model.





**Figure 175. Mean age from the conditional age data for the FL\_Recreational fleet (top) and SC\_Longline\_contemporary survey (bottom) for the southern stock SS base model.**

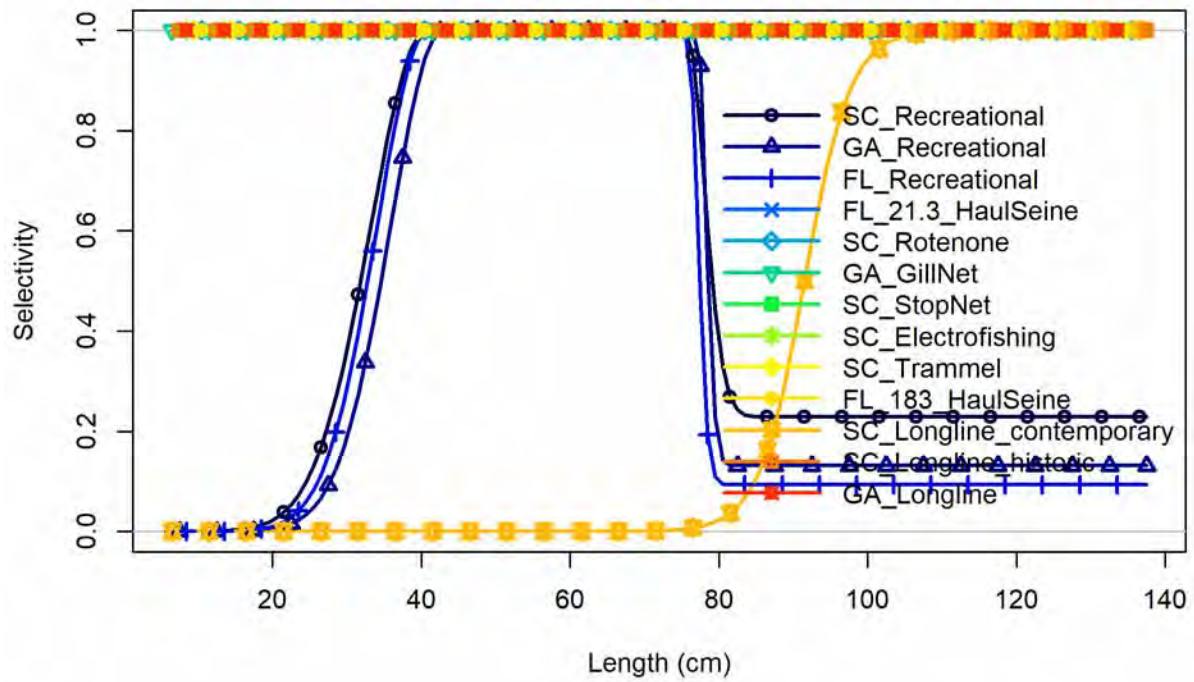
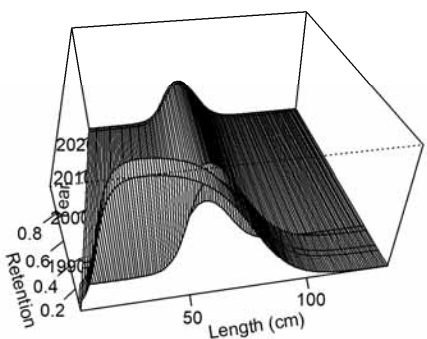
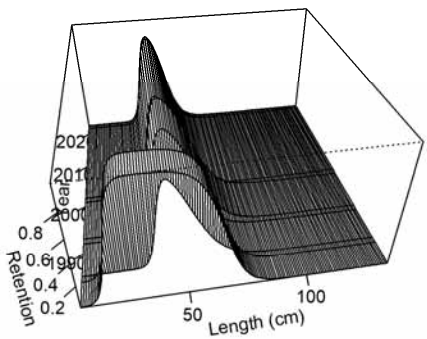
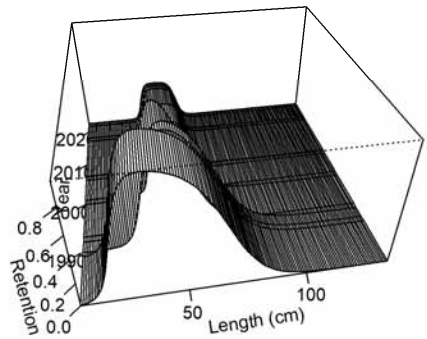
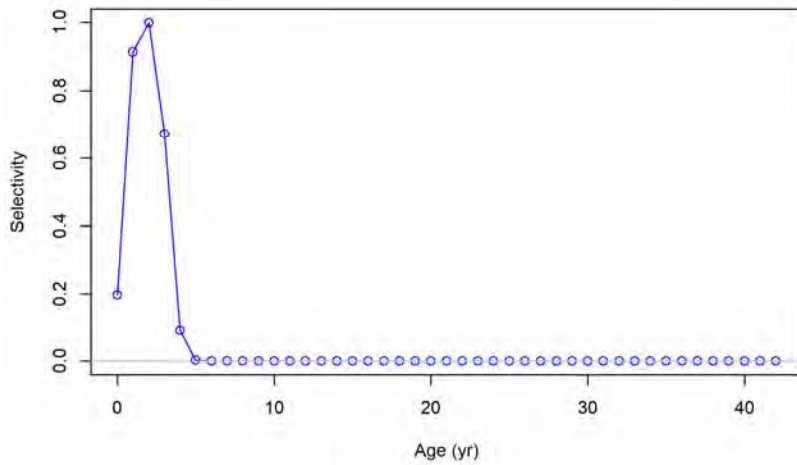
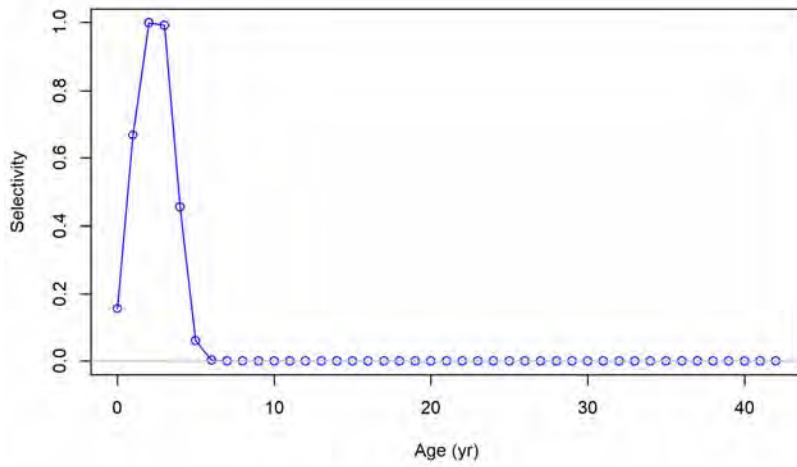
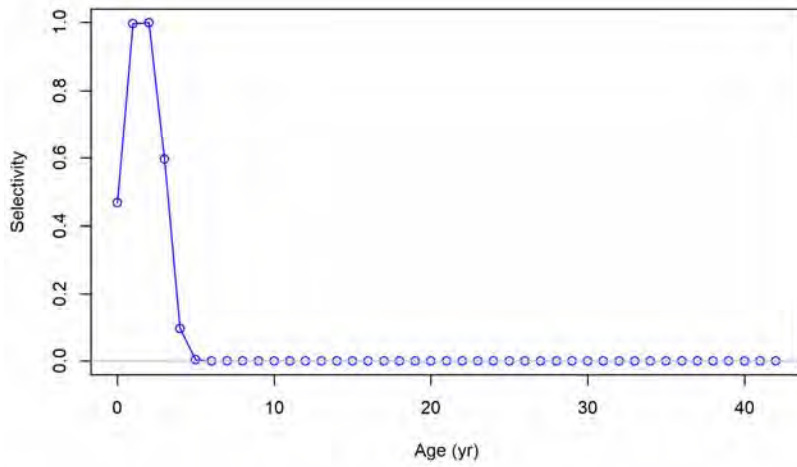


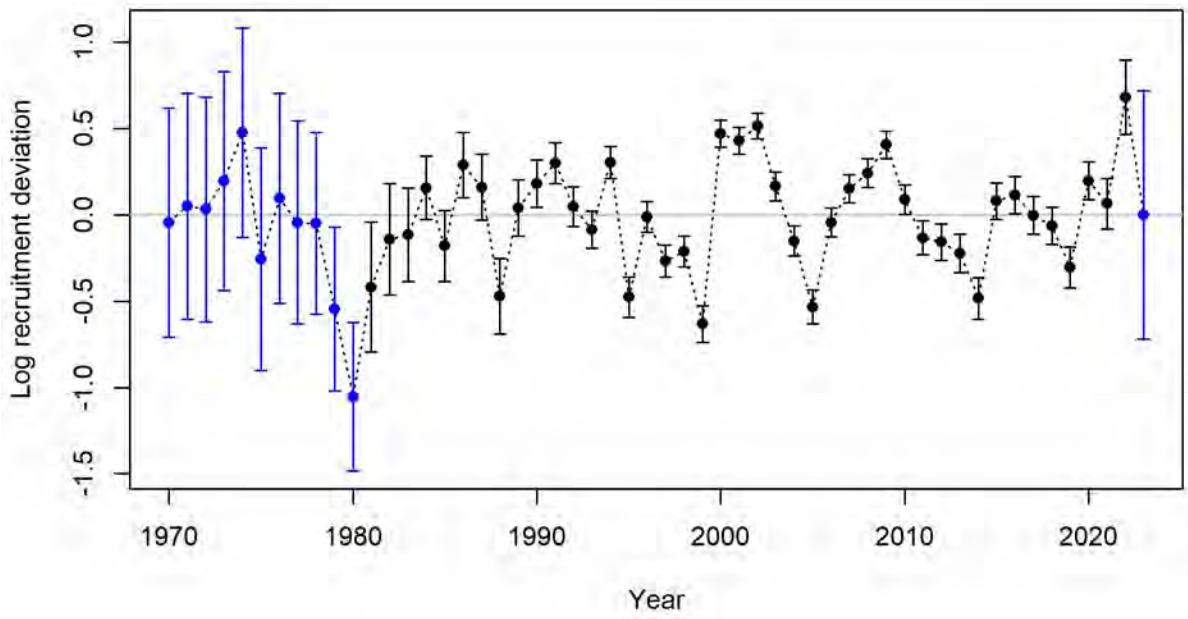
Figure 176. Length based selectivities for the southern stock SS base model. The SC\_Longline\_contemporary survey selectivity is fixed.



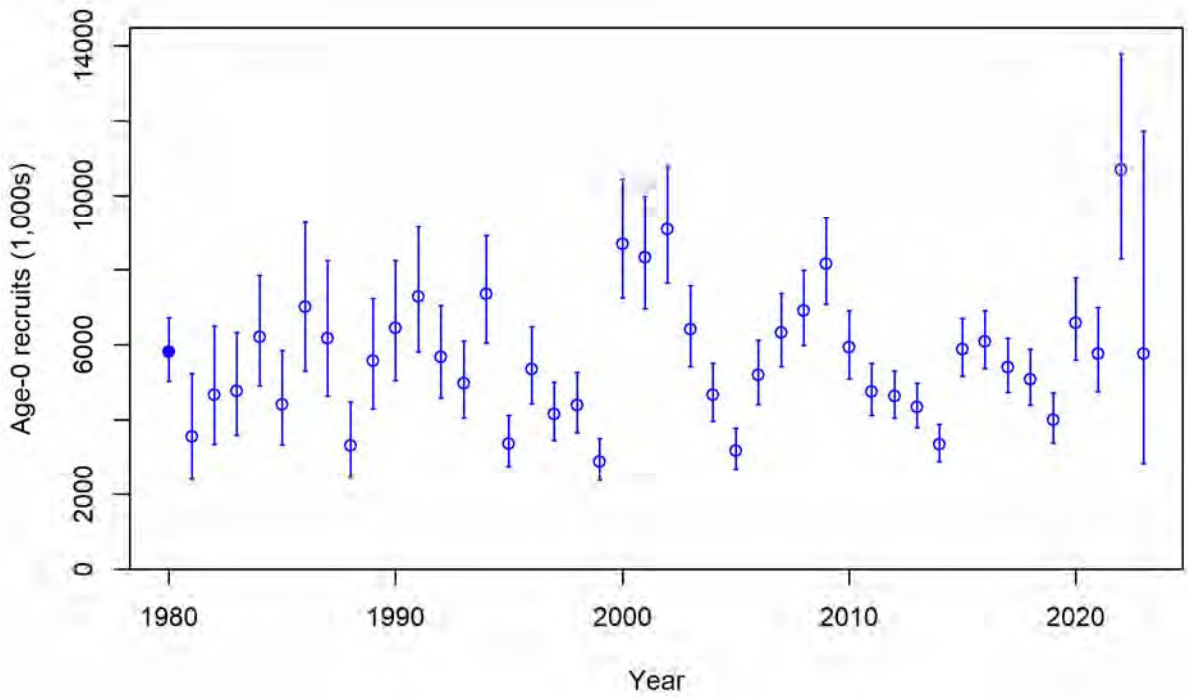
**Figure 177. Retention estimates, by regulatory period, for the SC\_Recreational (top), GA\_Recreational (middle), and FL\_Recreational (bottom) fleets for the southern stock SS base model.**



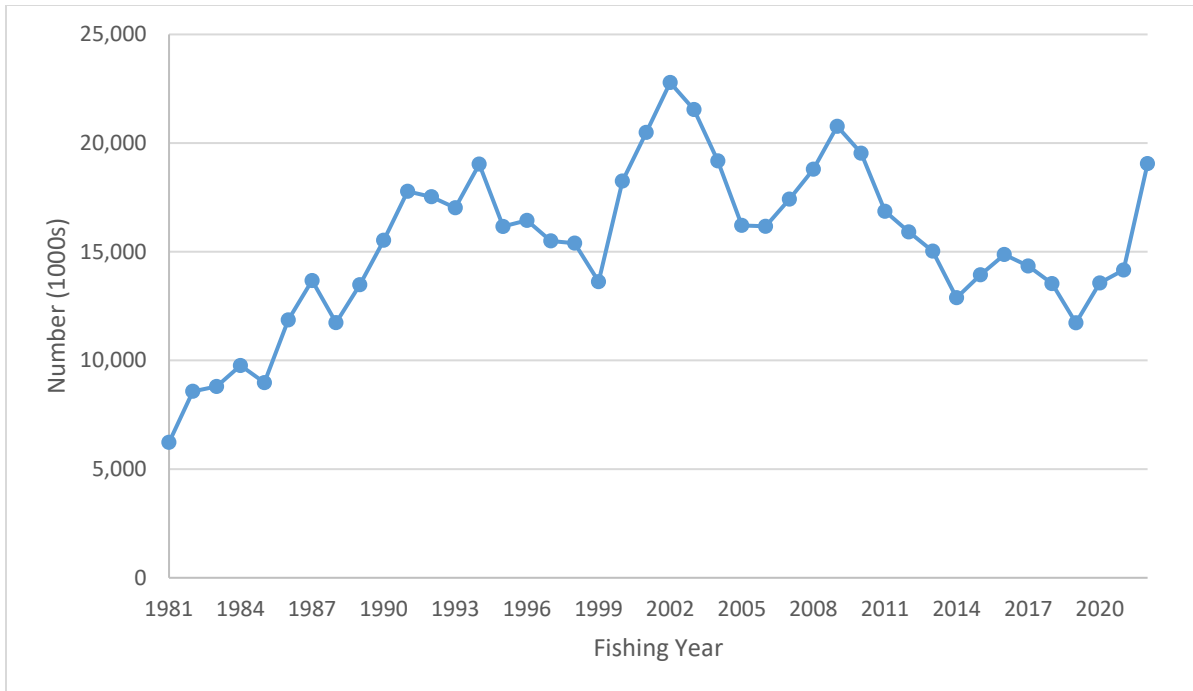
**Figure 178.** Age based selectivities estimated for the SC\_StopNet (top), SC\_Trammel (middle), and FL\_183\_HaulSeine (bottom) surveys for the southern stock SS base model.



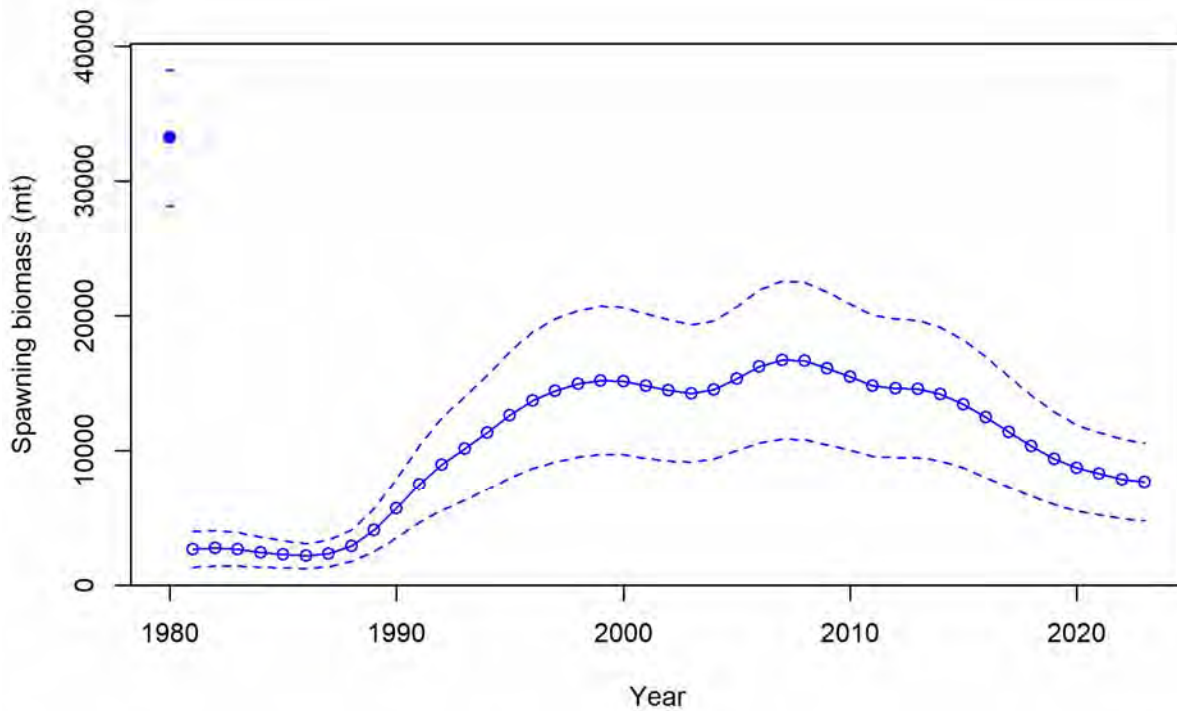
**Figure 179.** Recruitment deviations, with 95% confidence intervals from asymptotic standard errors, for the southern stock SS base model.



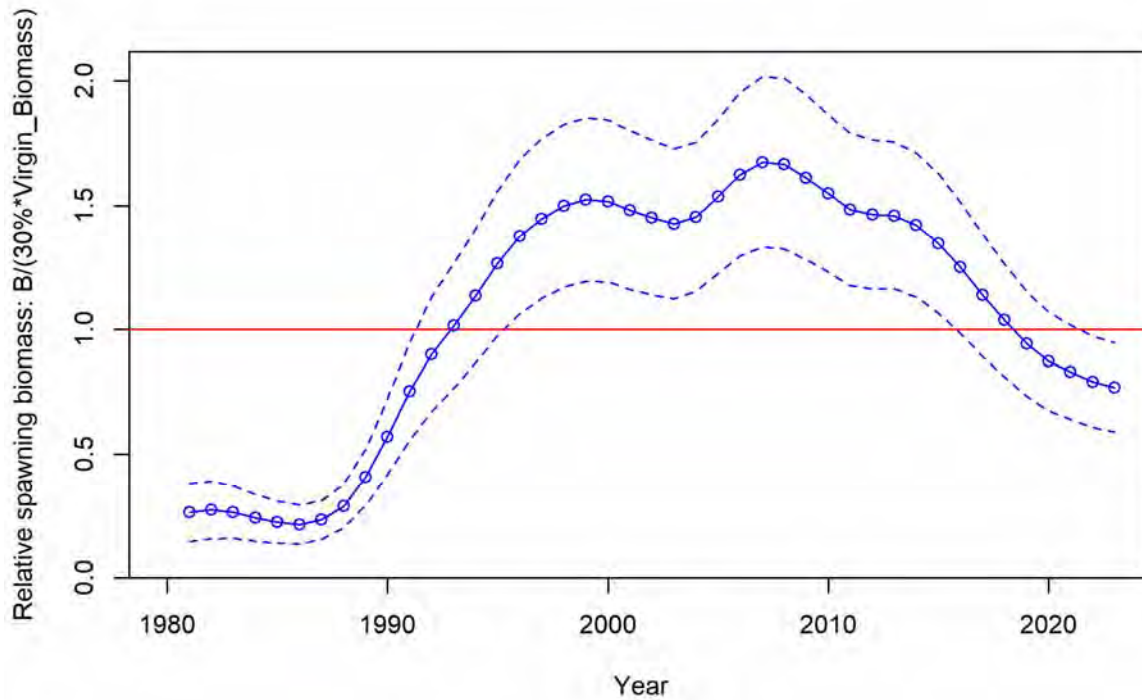
**Figure 180.** Estimated recruitment (in 1000s) for the southern stock SS base model. Error bars are 95% confidence intervals based on asymptotic standard errors.



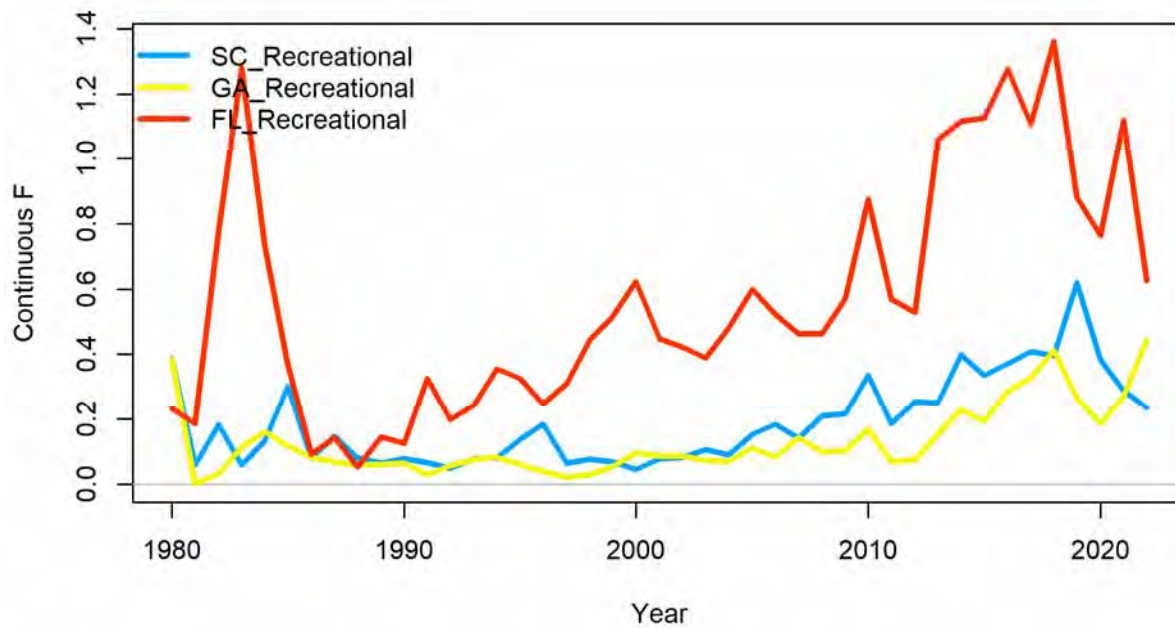
**Figure 181. Estimated population abundance (in 1000s of fish) for the southern stock SS base model.**



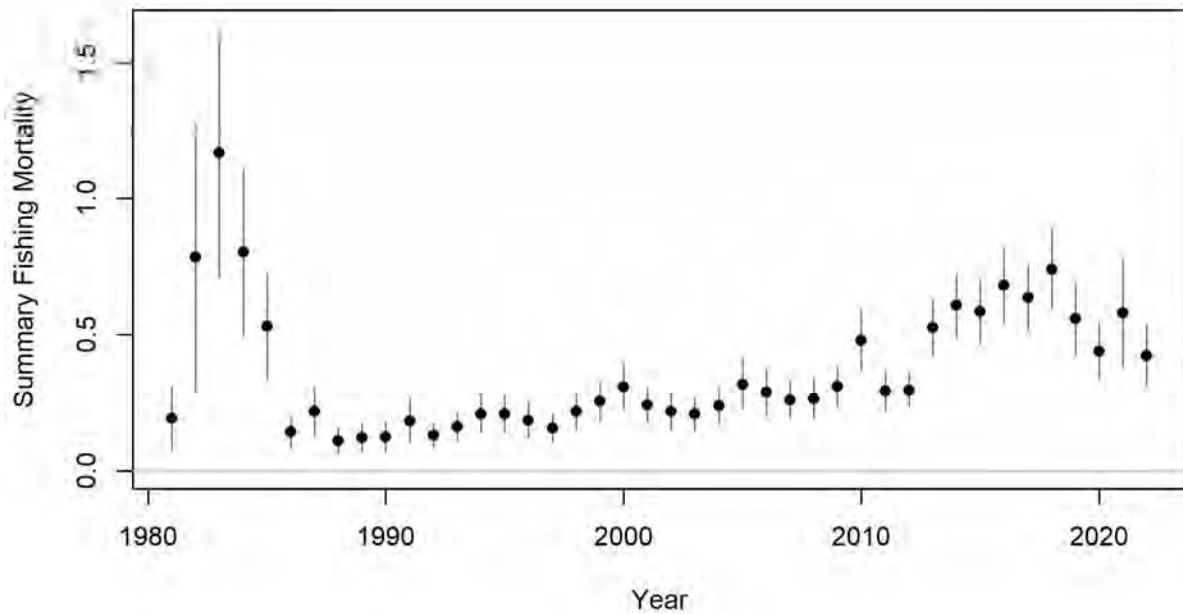
**Figure 182. Estimated female SSB (metric tons) for the southern stock SS base model. Error bars are 95% confidence intervals based on asymptotic standard errors.**



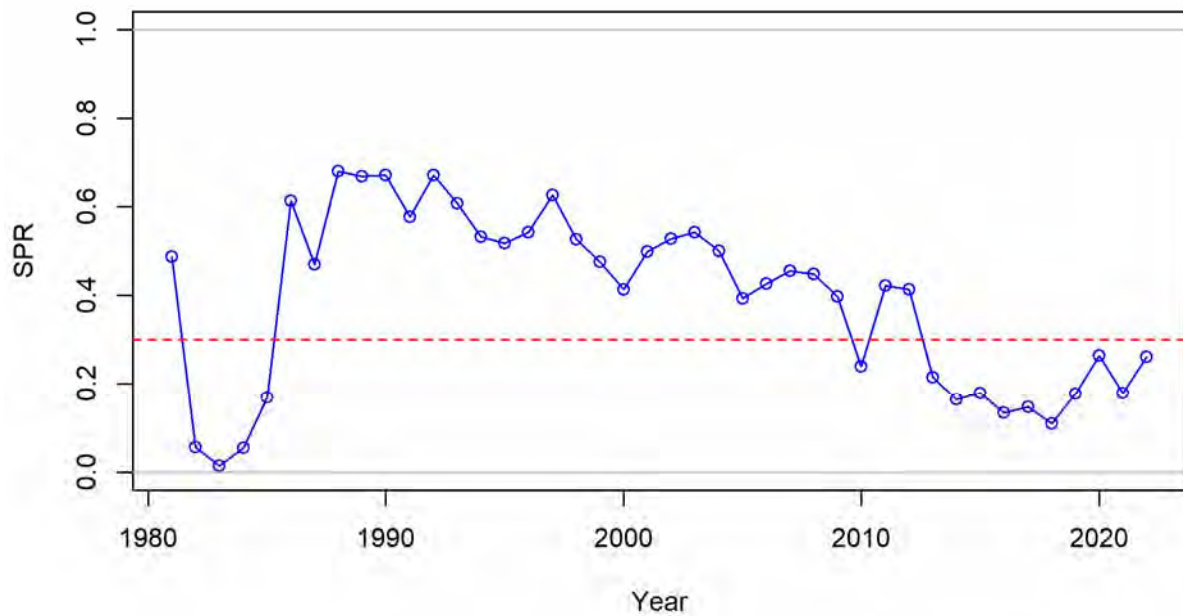
**Figure 183.** Estimated female SSB relative to the estimated SSB<sub>30%</sub> threshold for the southern stock SS base model. Error bars are 95% confidence intervals based on asymptotic standard errors.



**Figure 184.** Estimated fleet-specific fishing mortality (F) for age-2 fish for the southern stock SS base model.



**Figure 185. Total age-2 fishing mortality (F) for the southern stock SS base model. Error bars are 95% confidence intervals based on asymptotic standard errors.**



**Figure 186. SPR timeseries for the southern stock SS base model. Horizontal line is the SPR target (0.30).**



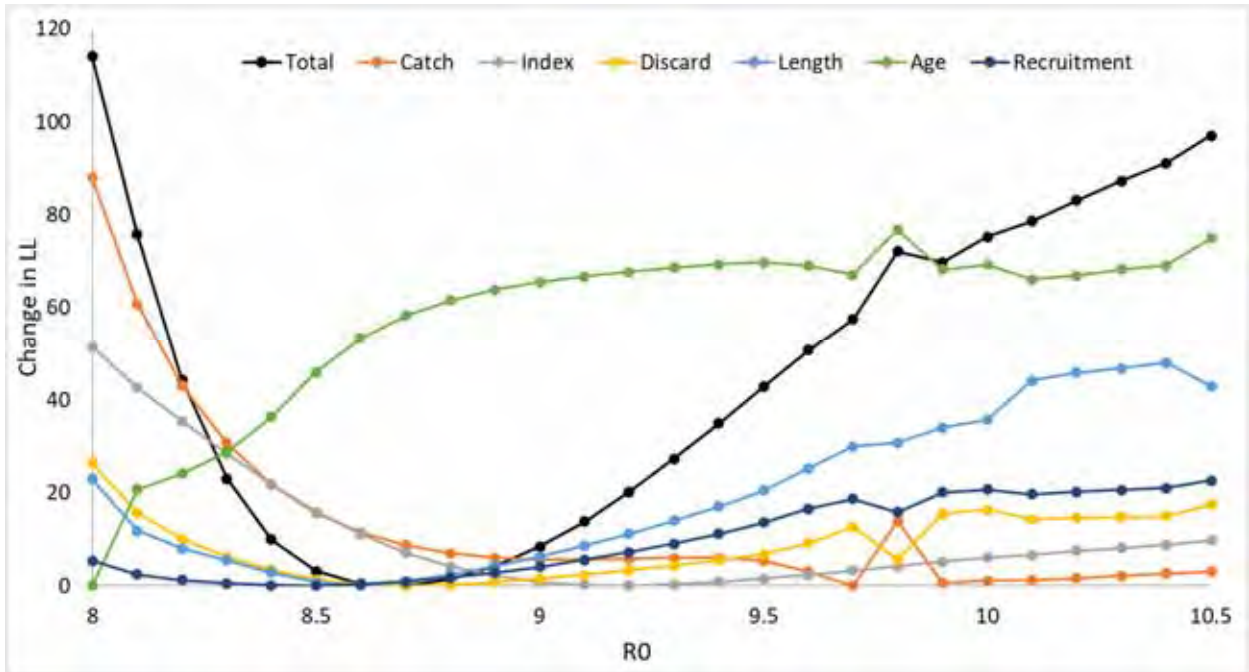
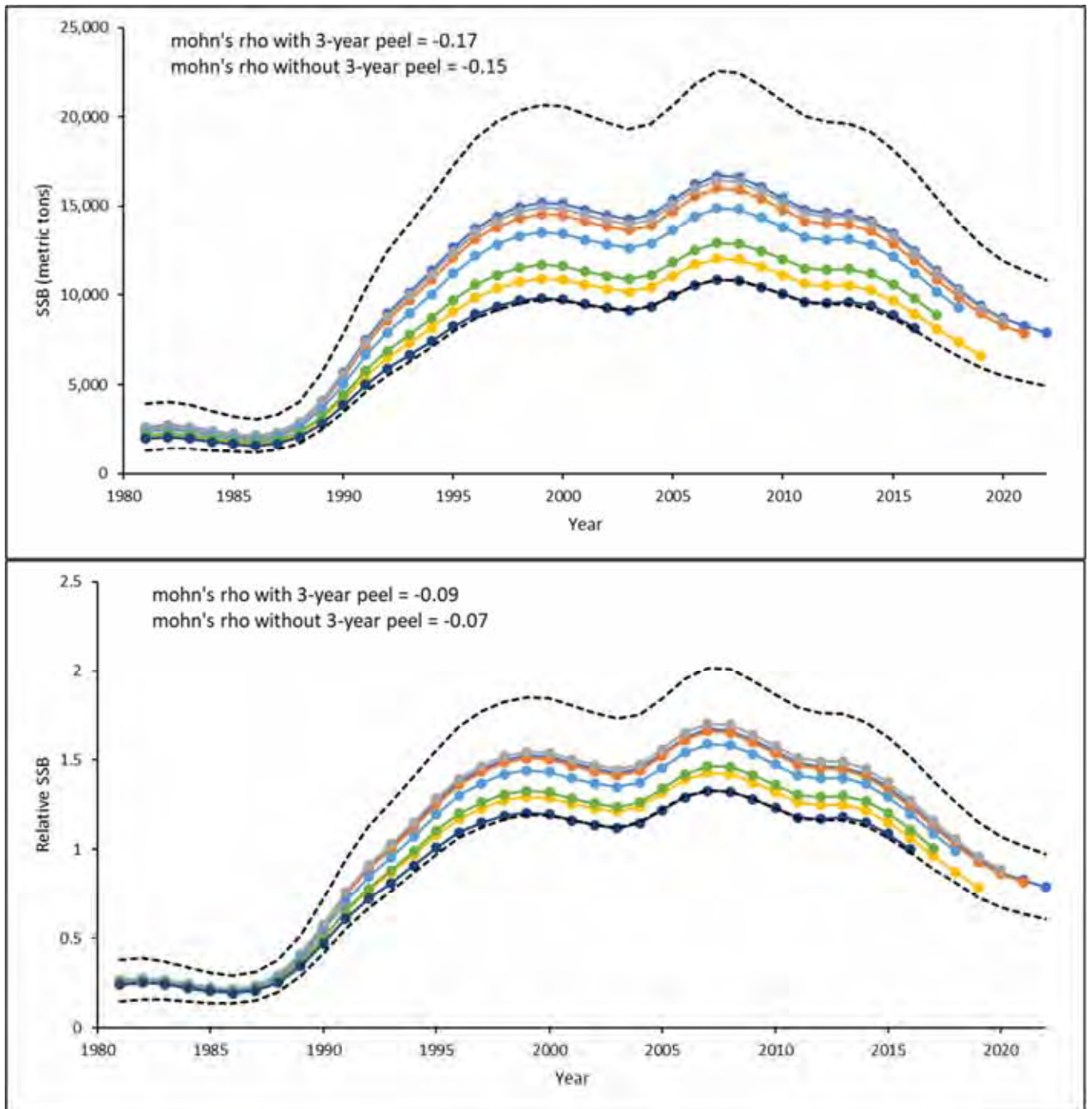
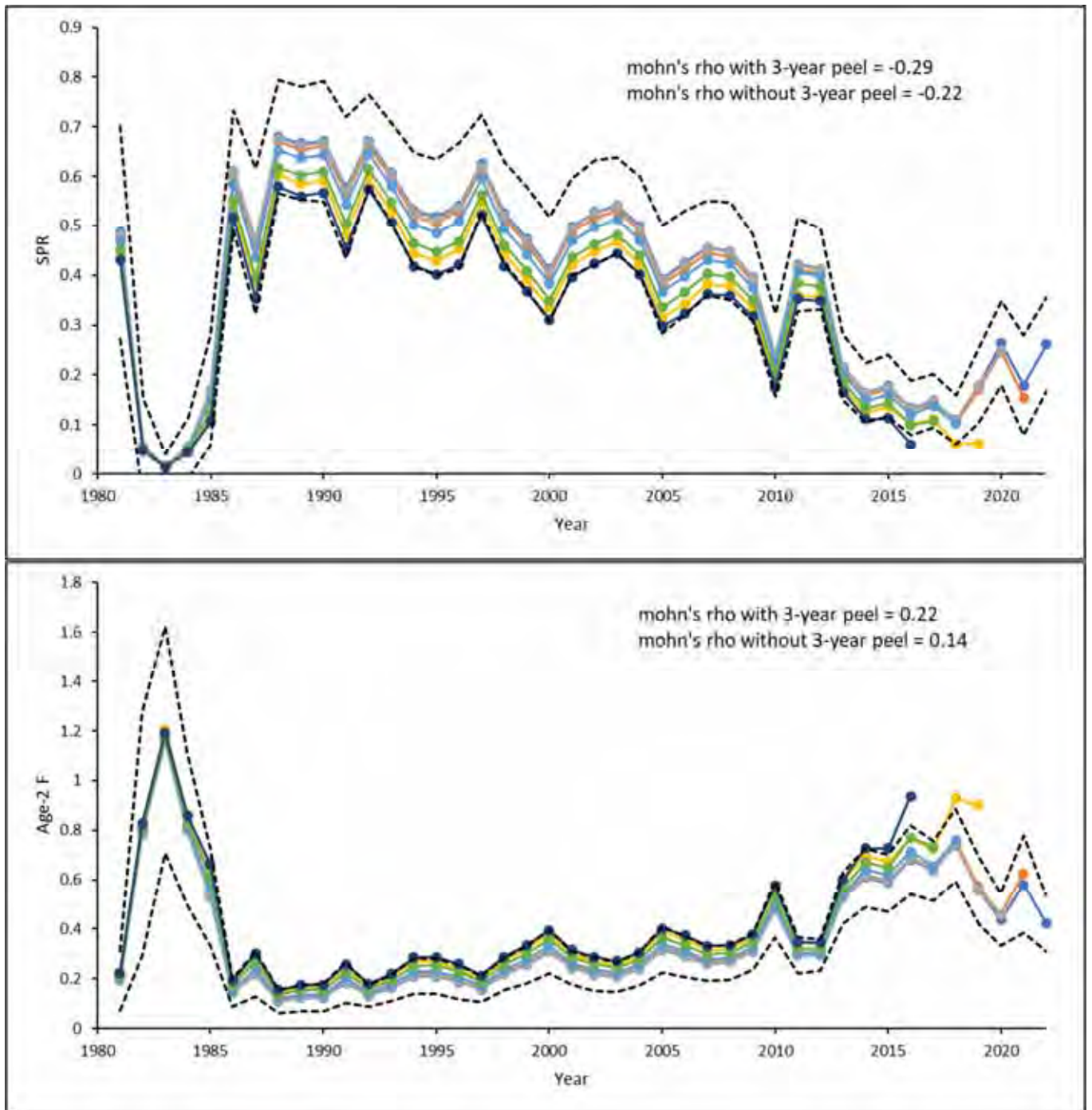


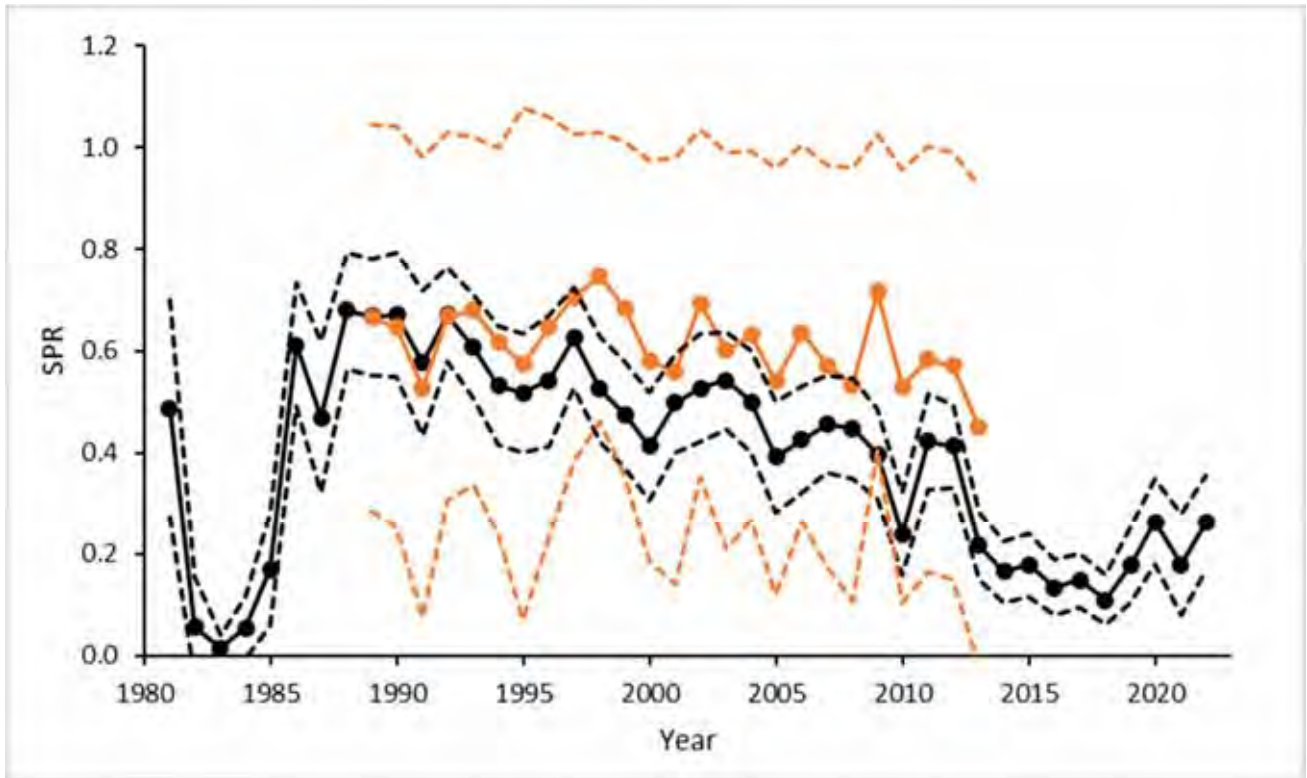
Figure 187. Likelihood profile plot for unfished recruitment (R0) parameter (on the log scale) for the southern stock SS model.



**Figure 188.** Spawning stock biomass and relative spawning stock biomass estimates from retrospective analysis of southern stock SS model. Black dashed lines are 95% confidence intervals based on asymptotic standard errors for base model estimates.



**Figure 189.** Spawning potential ratio and age-2 fishing mortality estimates from retrospective analysis of southern stock SS model. Black dashed lines are 95% confidence intervals based on asymptotic standard errors for base model estimates.



**Figure 190.** Spawning potential ratio estimates for the southern red drum stock from the previous benchmark stock assessment using a custom statistical catch-at-age model (ASMFC 2017; orange) and the current benchmark assessment SS base model (black). Dashed lines are 95% confidence intervals based on asymptotic standard errors. Estimates from the previous assessment are for calendar years while estimates in the current assessment are for fishing years.

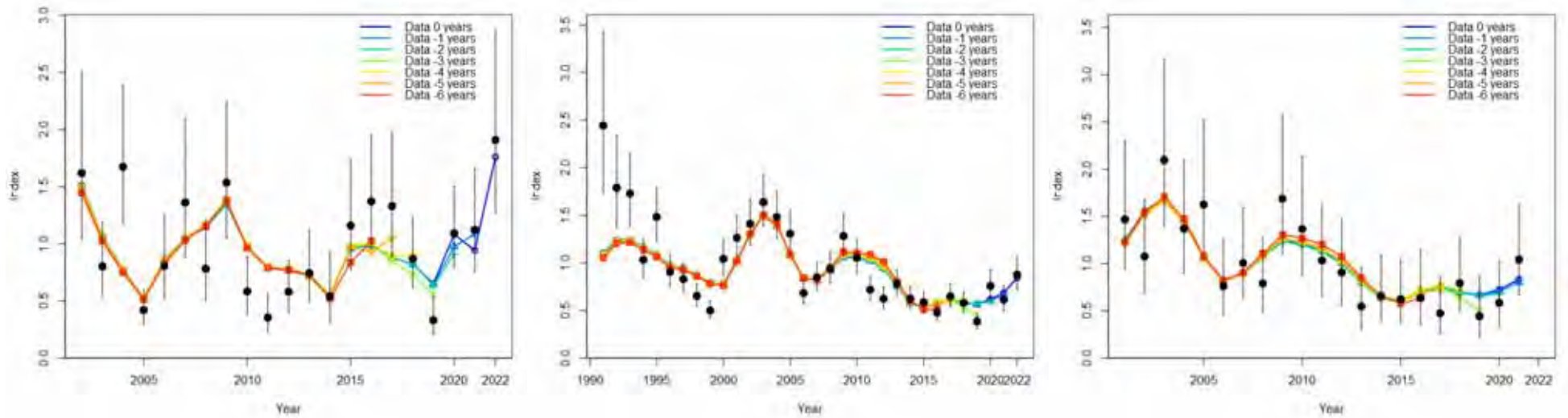
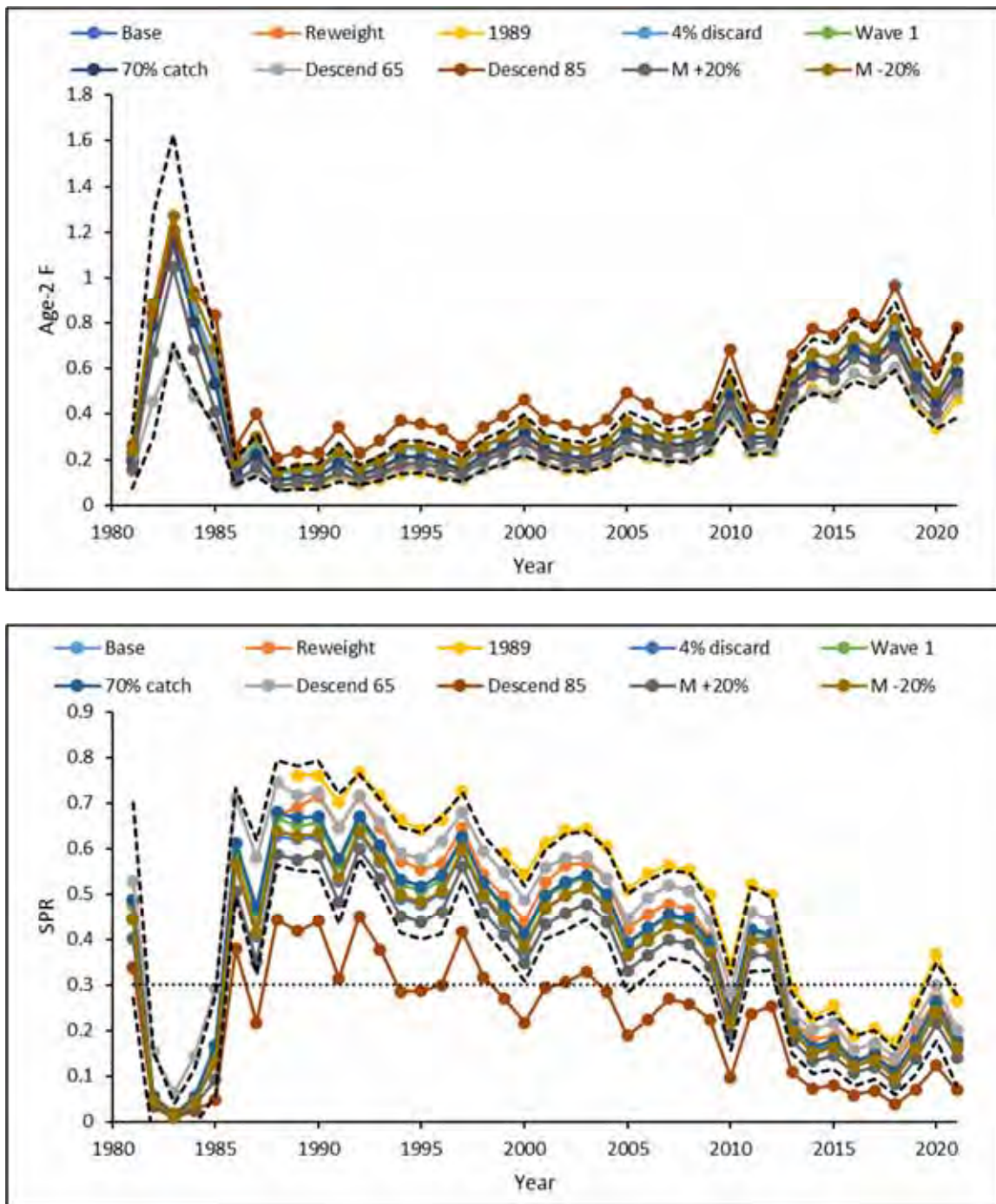
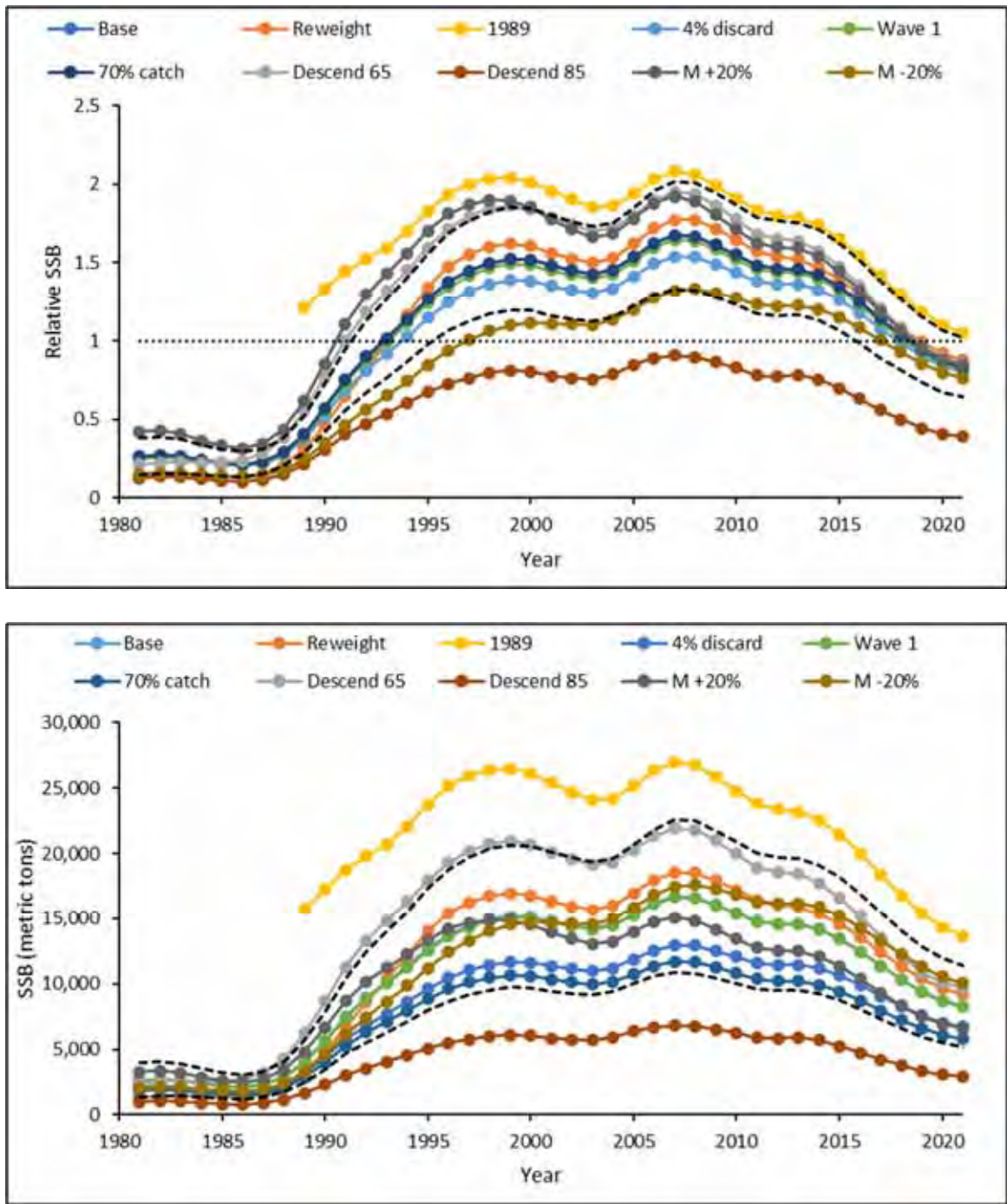


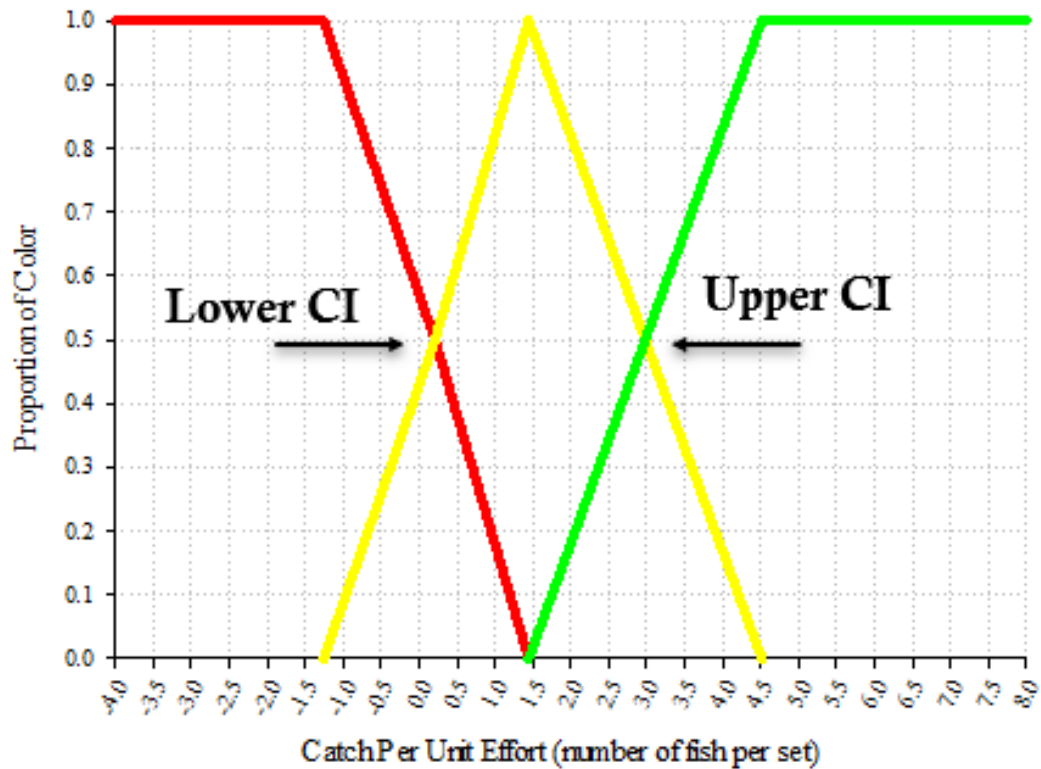
Figure 191. Observed and estimated index values for the GA\_GillNet (left), SC\_Trammel (middle), and FL\_183\_HaulSeine (right) surveys from the retrospective analysis for the southern stock SS model.



**Figure 192.** Age-2 fishing mortality and spawning potential ratio estimates from sensitivity analysis of southern stock SS model. Black dashed lines are 95% confidence intervals based on asymptotic standard errors for base model estimates. The dotted black horizontal line is the SPR threshold.

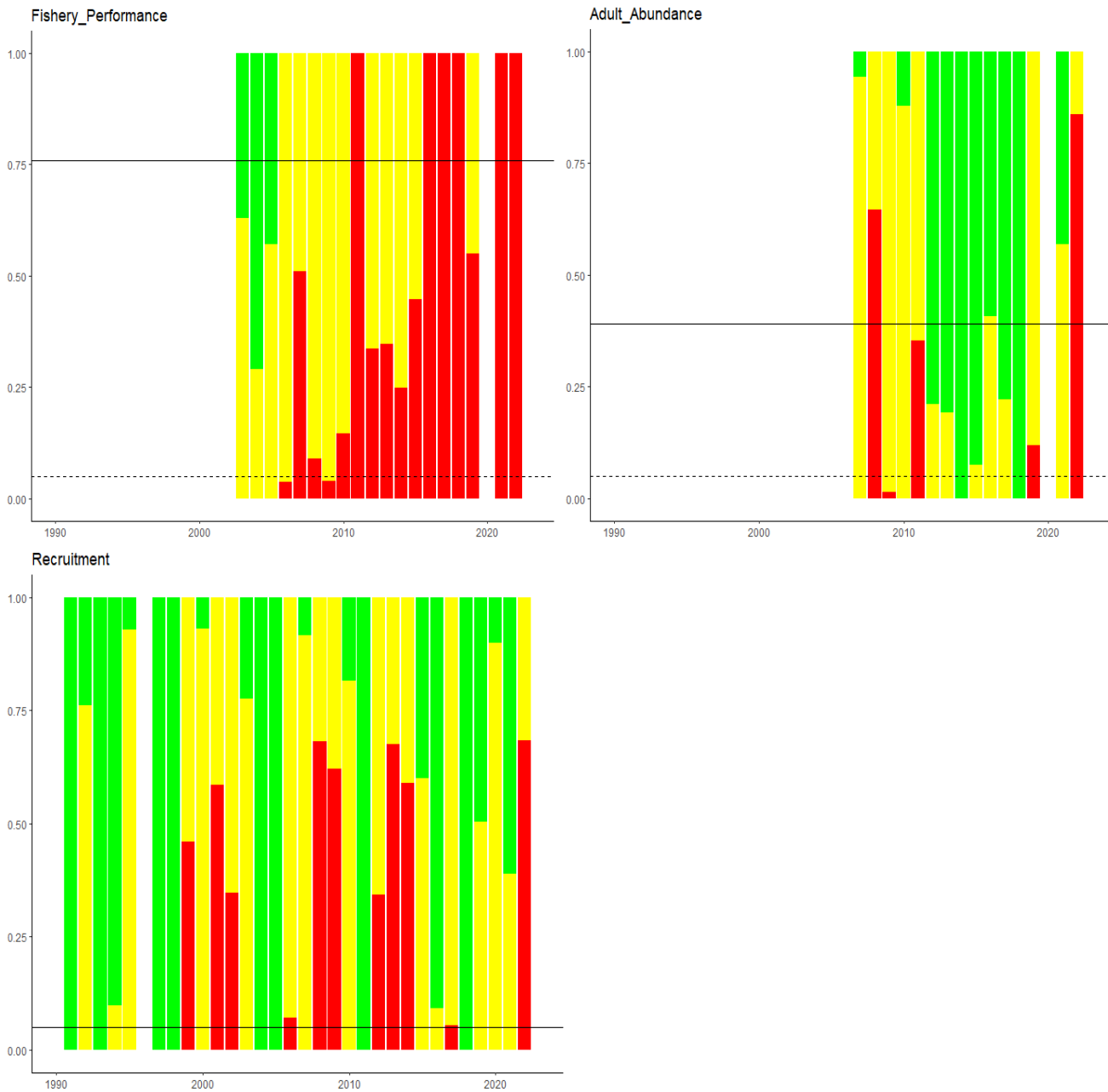


**Figure 193.** Relative spawning stock biomass and spawning stock biomass estimates from sensitivity analysis of southern stock SS model. Black dashed lines are 95% confidence intervals based on asymptotic standard errors for base model estimates. The dotted black horizontal line is the relative biomass threshold.

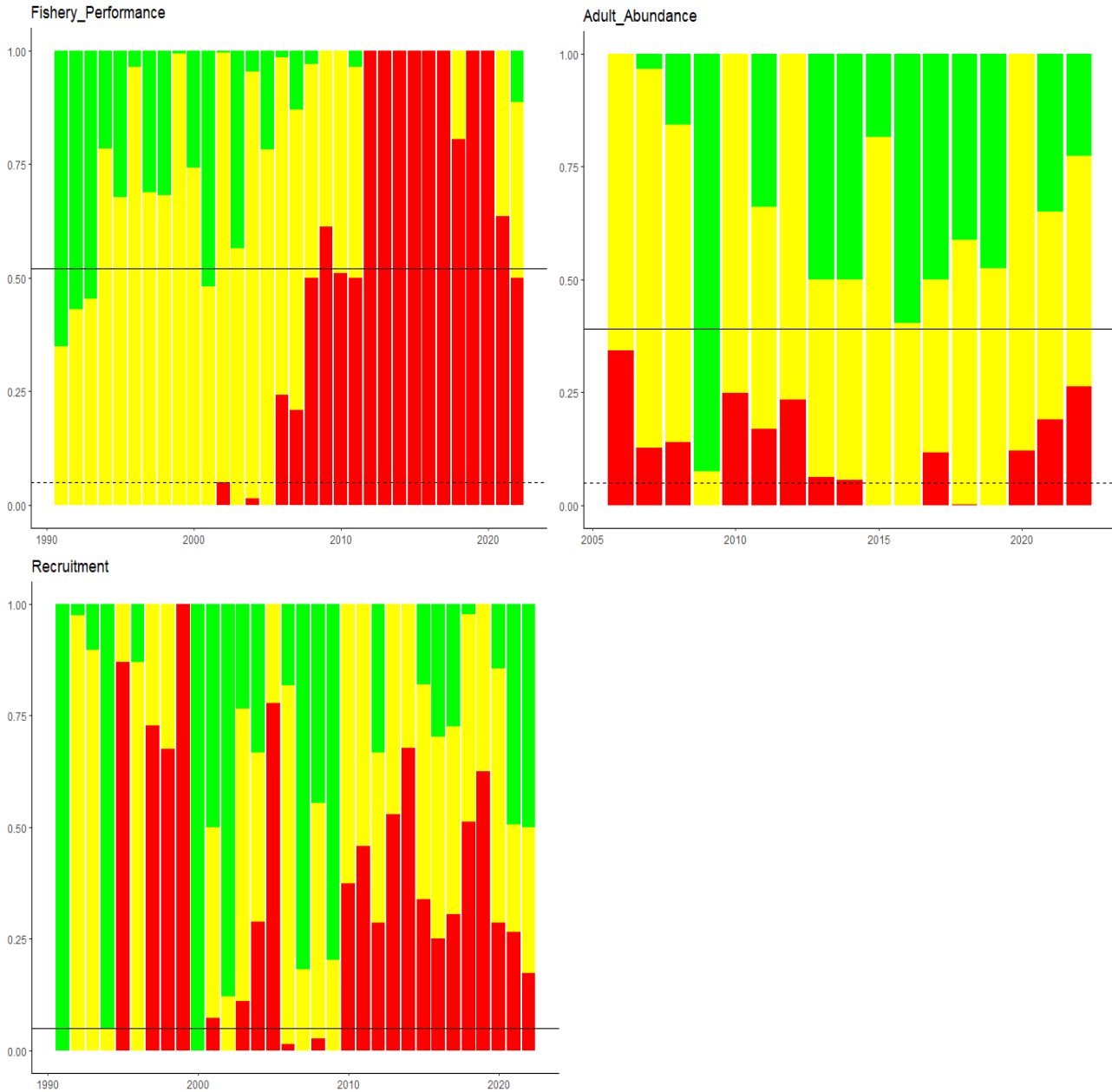


**Figure 194.** Graphical representation of traffic light analysis fuzzy method regression calculations of proportion of color using relative abundance index data. Intersection of red and yellow lines occurs at the lower 95% confidence interval and the intersection of yellow and green lines occurs at the upper 95% confidence interval. Figure adapted from ASMFC (2020).

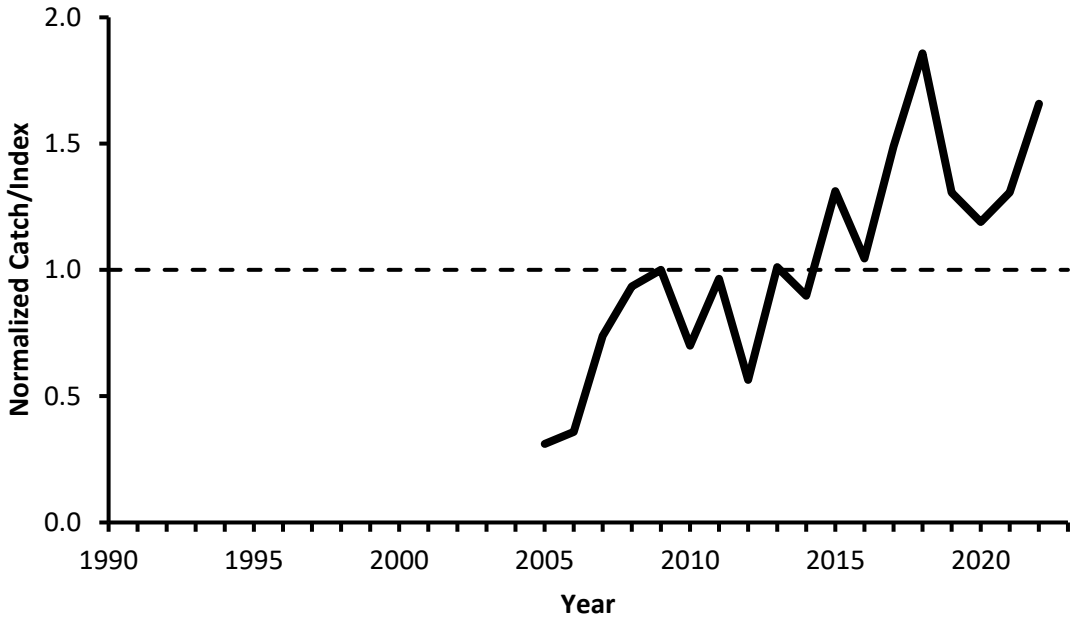




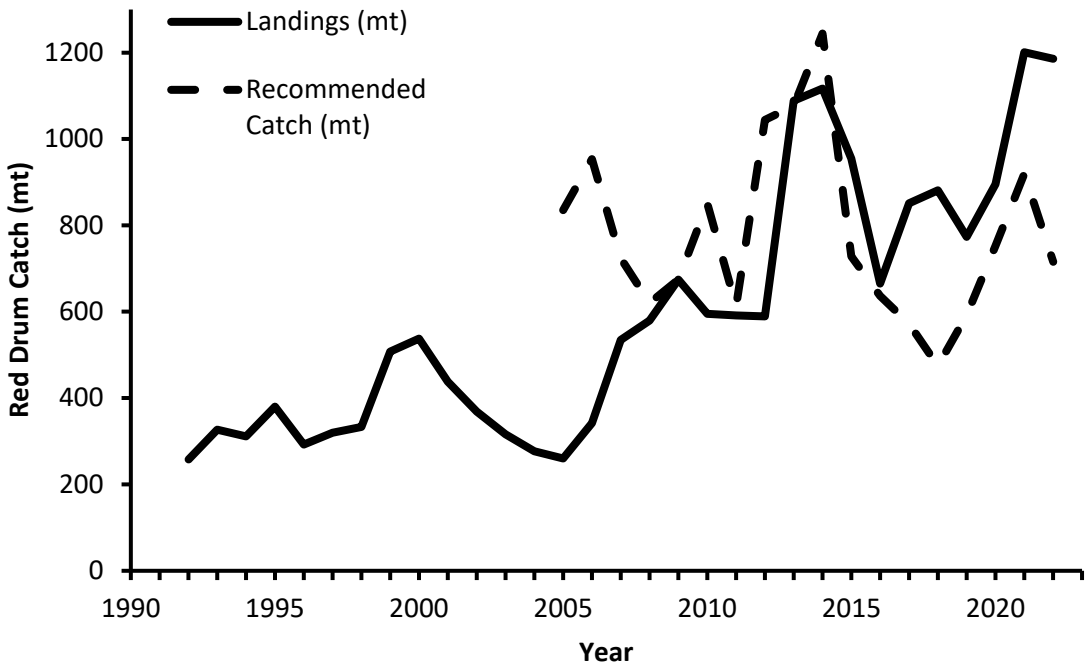
**Figure 195. Annual TLA results for each selected characteristic in the northern stock. Threshold values are represented by the solid horizontal line. The color at the threshold is the color determination for that year.**



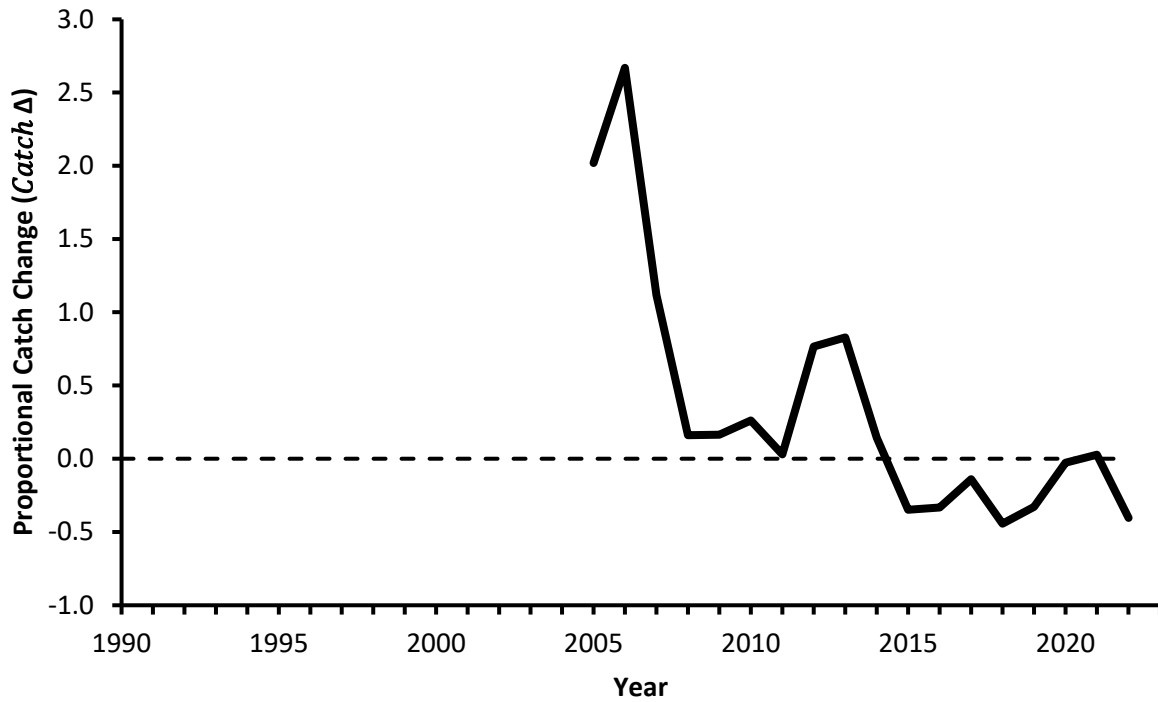
**Figure 196. Annual TLA results for each selected characteristic in the southern stock. Threshold values are represented by the solid horizontal line. The color at the threshold is the color determination for that year.**



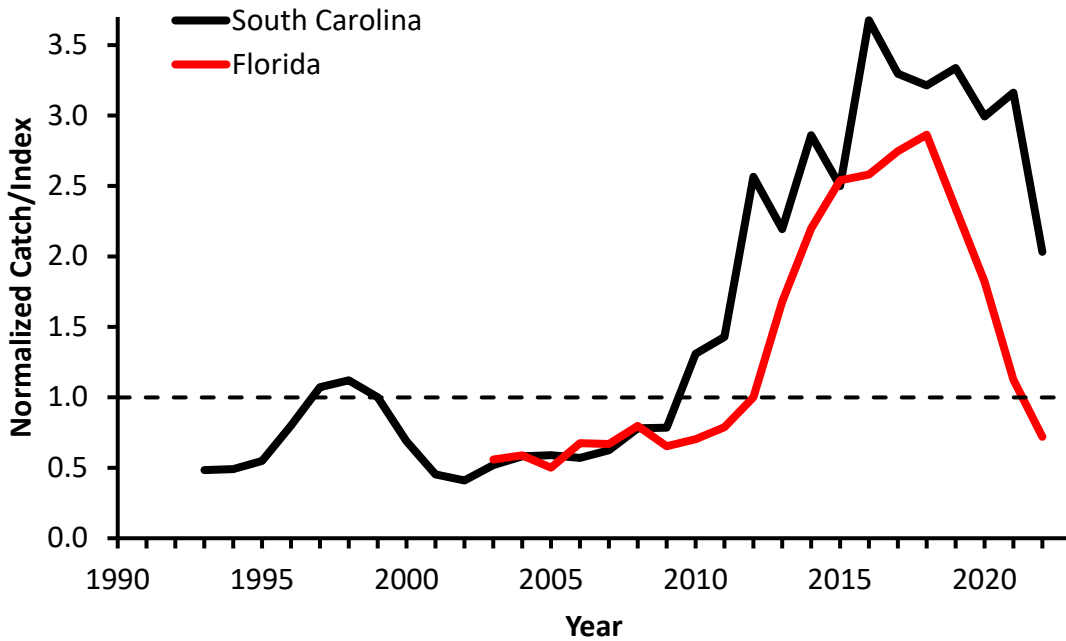
**Figure 197.** Normalized catch:index ratio for the northern stock using MRIP data recreational harvest of red drum in North Carolina and states further north + North Carolina commercial harvest and the NCDMF gill net index.



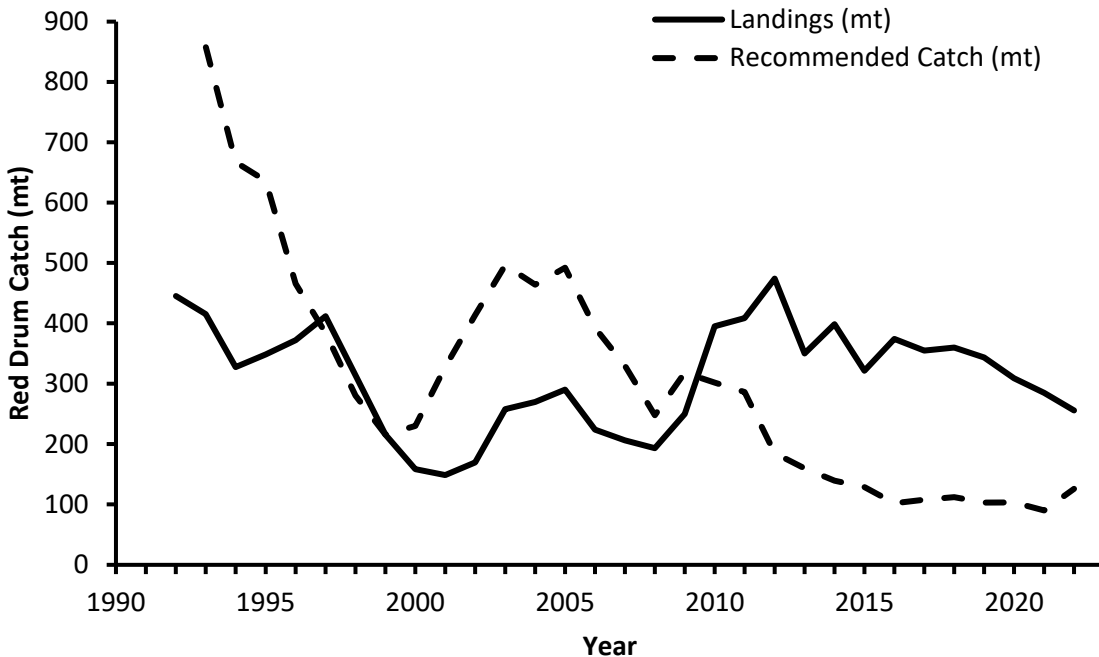
**Figure 198.** Time series of observed (solid line) and recommended (dashed line) northern stock catch based on Skate analysis using MRIP data on North Carolina and states further north recreational harvest + North Carolina commercial harvest and the NCDMF gill net index.



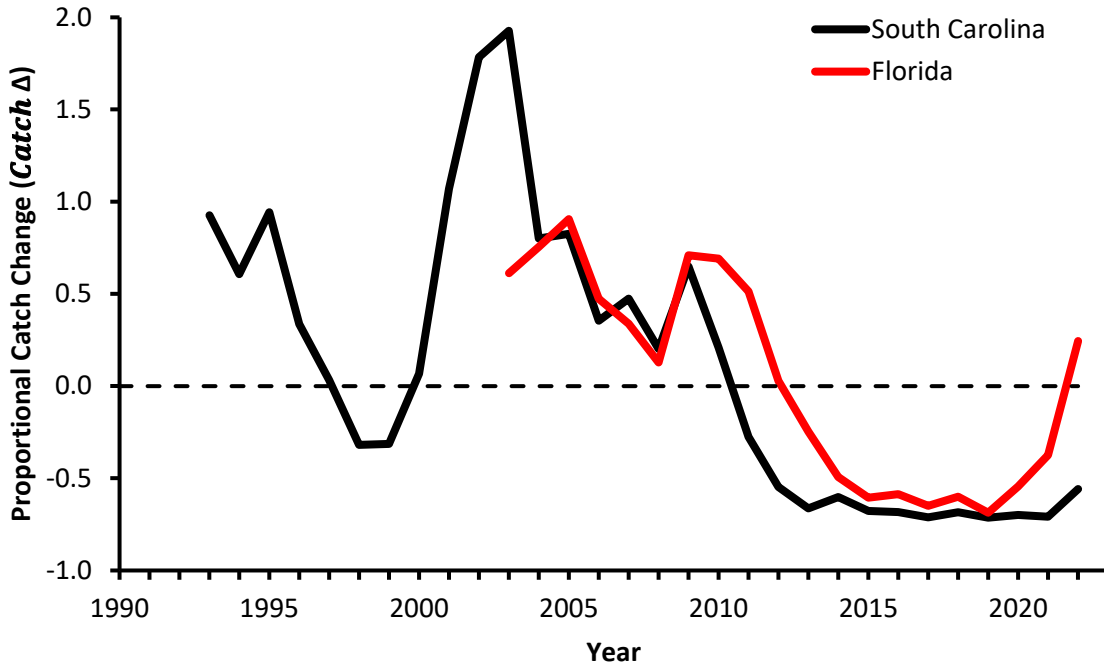
**Figure 199.** Proportional change in catch (Catch  $\Delta$ ) relative to previous fishing year as estimated for the northern stock using the Skate method. No change is denoted by the dashed line at 0, with a reduction in catch (relative to the previous year) needed when less than 0 and vice versa when above.



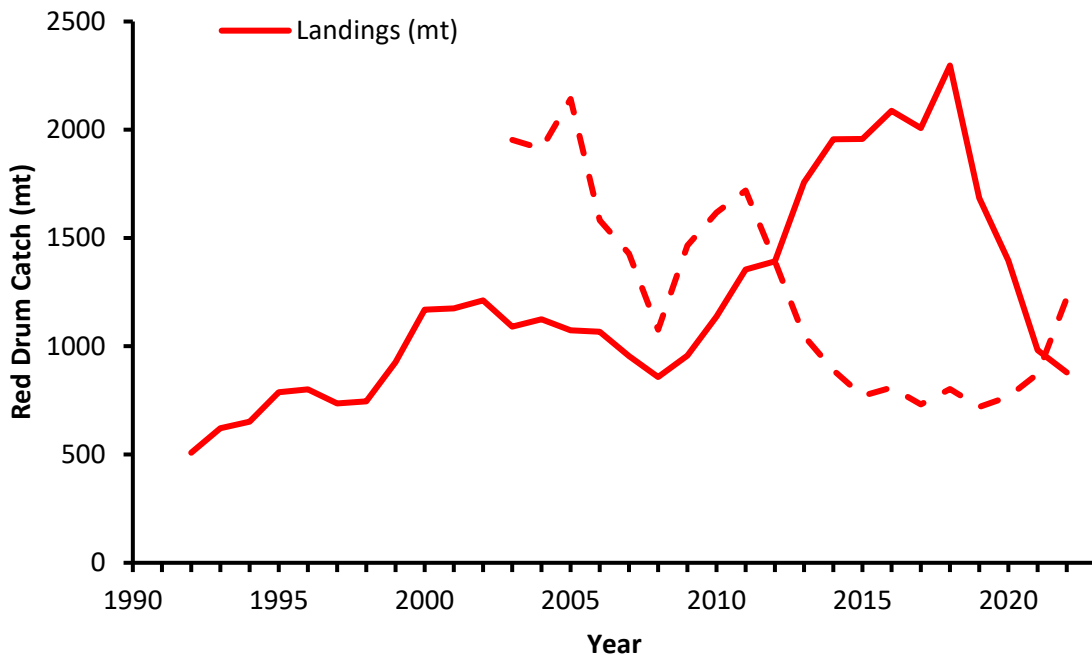
**Figure 200.** Normalized catch:index ratio for South Carolina (black line) and Florida (red line) and normalized relative F (black dashed line). South Carolina data used MRIP data on South Carolina recreational harvest and the SCDNR ages-2 and -3 trammel net index. Florida data used MRIP data on Florida recreational harvest and the FL FWRI 183 m haul seine survey.



**Figure 201.** Time series of observed (solid line) and recommended (dashed line) South Carolina catch based on Skate analysis using MRIP data on South Carolina recreational harvest and the SCDNR ages-2 and -3 trammel net index.



**Figure 202.** Proportional change in catch ( $Catch \Delta$ ) relative to previous fishing year as estimated for South Carolina (black line) and Florida (red line) using the Skate method. No change is denoted by the dashed line at 0, with a reduction in catch (relative to the previous year) needed when less than 0 and vice versa when above.



**Figure 203.** Time series of observed (solid line) and recommended (dashed line) Florida catch based on Skate analysis using MRIP data on Florida recreational harvest and the FL FWRI 183 m haul seine survey.

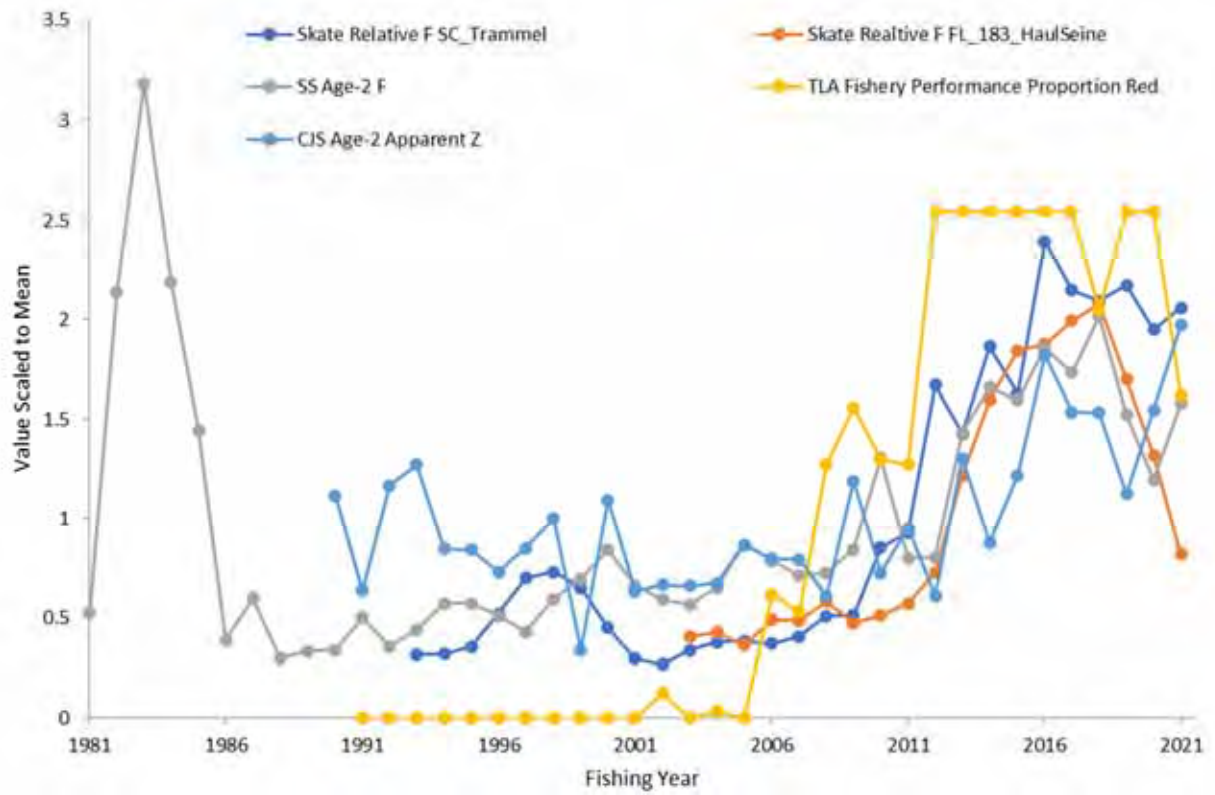


Figure 204. Comparison of scaled mortality estimates/metrics from analyses for the southern red drum stock.

## **12 APPENDIX A: OTHER DATA SOURCES CONSIDERED**

### **12.1 Fishery Dependent Data Sources**

#### **12.1.1 Commercial**

##### **Maryland Pound Net Sampling**

The Maryland Department of Natural Resources (MD DNR) has monitored commercial pound nets primarily in the Chesapeake Bay and mouth of the Potomac River since 1993. No cooperating fishermen could be located on the Potomac River in 2009 and sampling was not conducted in this area that year, but resumed in 2010. The lower portions of other rivers such as the Nanticoke and Hoga Rivers have been sampled sporadically depending on year. Generally, each site was sampled once every two weeks from May - September, weather and fisherman's schedule permitting. The commercial fishermen set their nets as part of their regular fishing activity. Net soak time and manner in which they were fished were consistent with the fisherman's day-to-day operations. All red drum captured were measured to the nearest mm TL (maximum or pinched). Other data collected includes water temperature (°C), salinity (ppt), and soak time (duration in minutes).

Red drum have been encountered sporadically throughout the 31 years of the commercial pound net survey, with none measured in nine years of the time series. Fifty-five percent of all red drum recorded by this survey were measured in 2012 (458 fish), a year of unusually high presence of red drum in the Chesapeake Bay. The TL of red drum has ranged from 187 – 1,332 mm, though almost all individuals encountered by this survey were outside of the commercial slot limit (18"-25"). None of the 458 red drum sampled in 2012 were of legal size.

Due to the limited sampling and relatively infrequent commercial harvest of red drum from Maryland waters, these data were not used in the stock assessment.

#### **12.1.2 Recreational**

##### **MRIP CPUE**

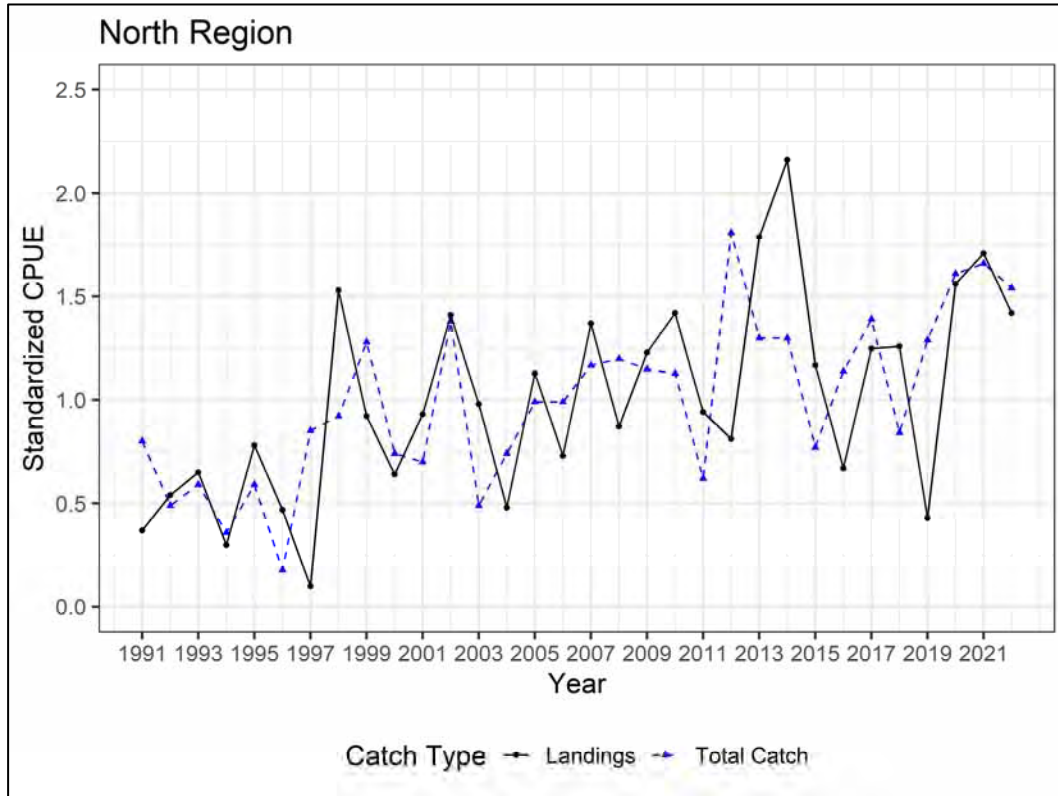
In addition to being used for total catch estimation, catch rate data collected during MRIP APAIS sampling (Section 4.2.1) have been used to generate relative indices of abundance for past red drum stock assessments and as such were updated at the beginning of this assessment. Standardized indices to account for factors affecting nominal catch rates using only landed catch as well as total catch (landed and released alive) were calculated using similar methods to those described in Appendix 1 of ASMFC 2022.

In the northern stock, catch rates increased throughout the time series, with high interannual variability (Figure A1).

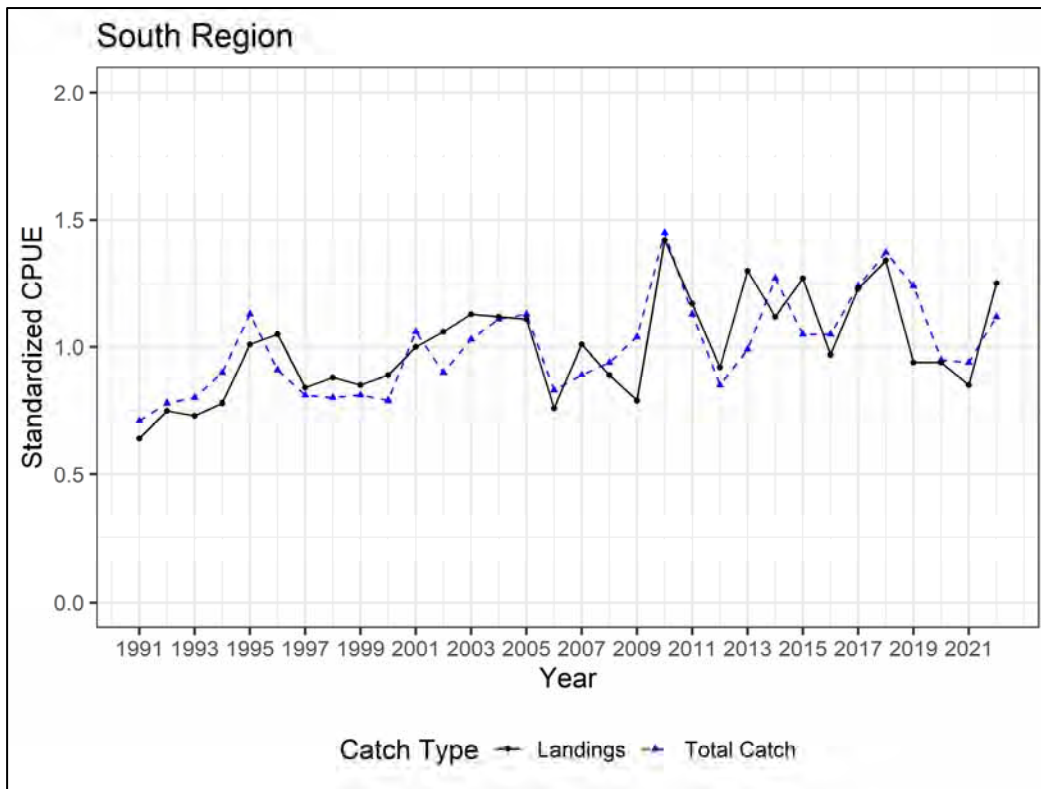


In the southern stock, standardized catch rates were variable with an increasing trend across the time series (Figure A2). There was a period of decline starting in 2019, before increasing again in 2022.

During this assessment, comparisons of these FD CPUE data sets to available FI indices of abundance indicated conflicts that may represent hyperstability of the MRIP CPUE. Given the conflicts and available FI indices tracking the same components of the population, the SAS decided not to use these data sets in the stock assessment.



**Figure A1.** Standardized indices of abundance for red drum caught within inshore waters of the northern sock (Virginia and North Carolina) using hook and line gear calculated from MRIP APAIS data.



**Figure A2.** Standardized indices of abundance for red drum caught within inshore waters of the southern stock (South Carolina, Georgia, and Florida) using hook and line gear calculated from MRIP APAIS data.

*Southeast Region Headboat Survey*

The Southeast Region Headboat Survey samples the recreational fishery headboat mode in states from North Carolina through Florida to generate estimates of catch and effort. Data through 2009 was considered during the SEDAR 18 stock assessment but deemed not useful due to inconsistent and low catches. The data were revisited during this assessment to determine if any changes in catches had occurred in South Atlantic headboats. Red drum encounters remain inconsistent and low, ranging from 0-148 fish per year from 1980-2021 with 823 fish observed over the time series. These data were not included in the assessment but should be reviewed periodically in future assessments to determine if red drum catches become more substantial.

*South Carolina Charterboat Logbook Program*

In 1993, SCDNR’s Marine Resources Division (MRD) initiated a mandatory trip-level logbook reporting system for all charter vessels to collect basic catch and effort data. Under state law, vessel owners/operators purchasing South Carolina Charter Vessel Licenses and carrying fishermen on a for-hire basis, are required to submit trip level reports of their fishing activity. Logbook reports are submitted to the SCDNR Fisheries Statistics section monthly either in person, by mail, fax, or scan and beginning in 2016, electronically through a web-based

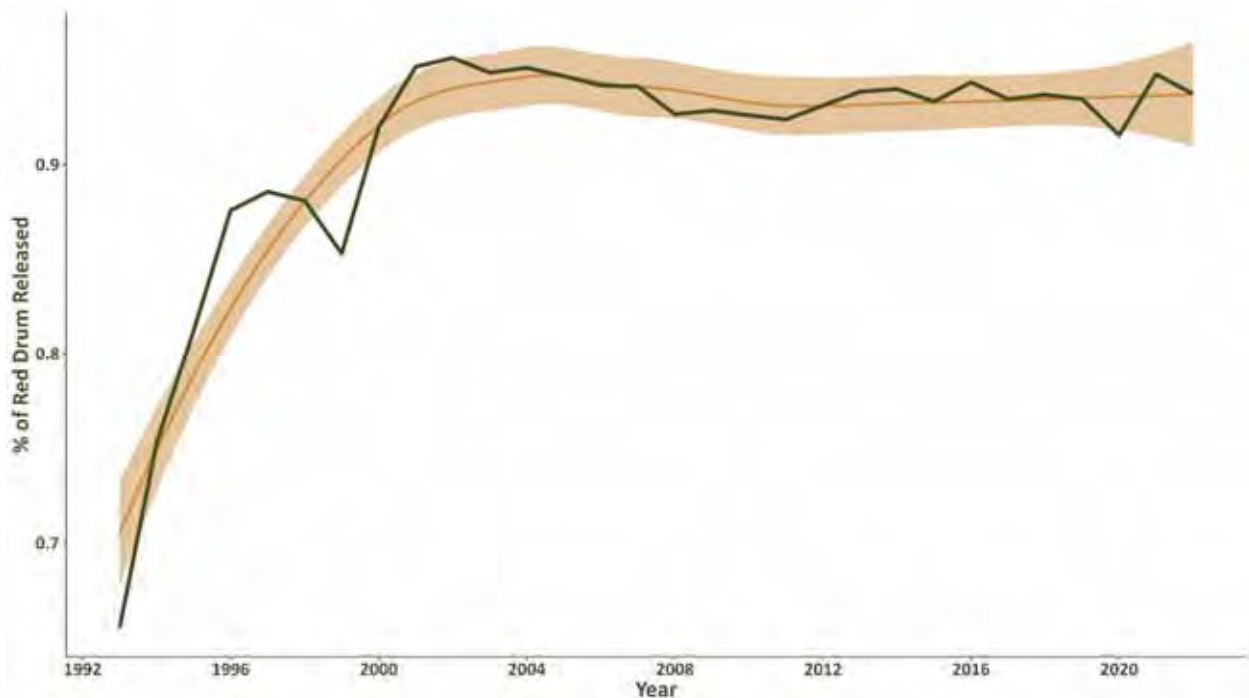
application. Reporting compliance is tracked by staff, and charter vessel owners/operators failing to submit reports can be charged with a misdemeanor. The charterboat logbook program is a complete census and should theoretically represent the total catch and effort of the charterboat trips in waters off of SC.

The charterboat logbook reports include: date, number of fishermen, fishing locale (inshore, 0-3 miles, >3 miles), fishing location (based on a 10x10 mile grid map), fishing method, hours fished, target species, depth range (minimum/maximum), catch (number of landed vs. released fish by species), and estimated landed pounds per vessel per trip. The logbook forms have remained similar throughout the program's existence with a few exceptions: in 1999 the logbook forms were altered to begin collecting the number of fish released alive and the number of fish released dead (prior to 1999 only the total numbers of fish released were recorded) and in 2008 additional fishing methods were added to the logbook forms, including cast, cast and bottom, and gig. Furthermore, the fishing method dive was added in 2012.

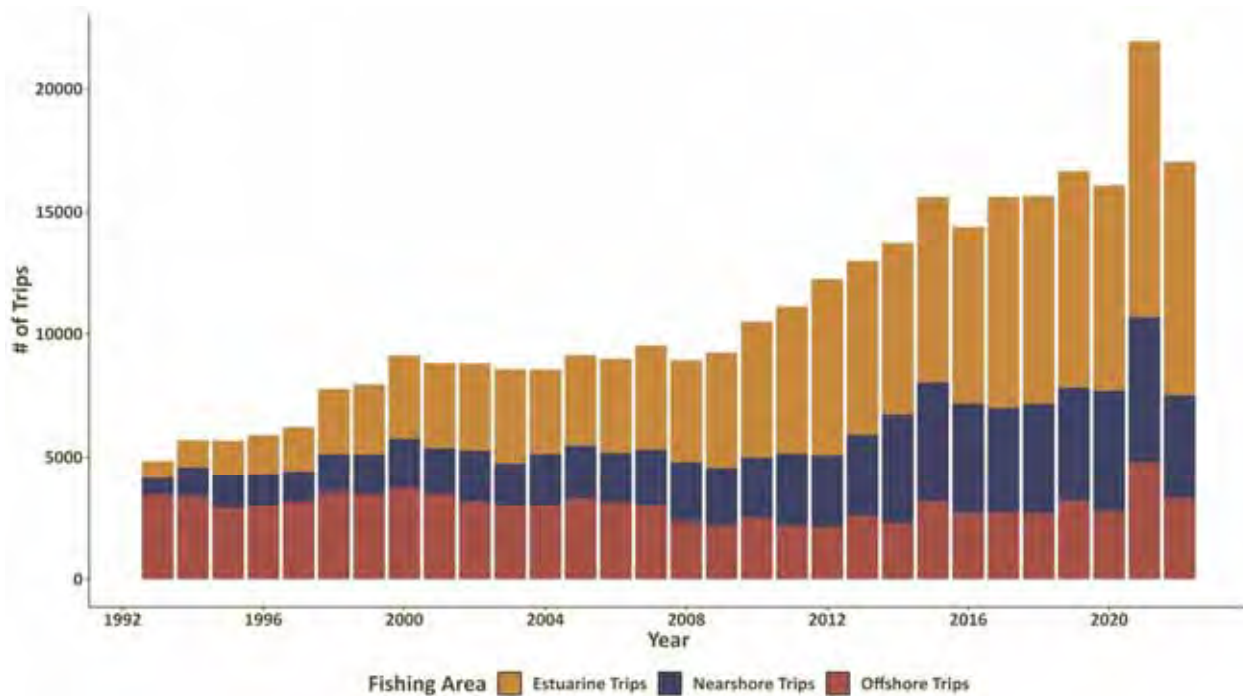
After being tracked for compliance, each charterboat logbook report is coded and entered, or uploaded into an existing database. Since the inception of the logbook program, a variety of staff have coded the charterboat logbook data. From ~1999 to 2006, only information that was explicitly filled out by the charterboat owners/operators on the logbook forms were coded and entered into the database. No efforts were made to fill in incomplete reports. From 2007 to present, staff have tried to fill in these data gaps through outreach with charterboat owners/operators by making assumptions based on the submitted data (i.e., if a location description was given instead of a grid location – a grid location was determined; if fishing method was left blank – it was determined based on catch, etc.). From 1999 to 2006, each individual trip recorded was reviewed to look for anomalies in the data. Starting in 2007, queries were used to look for and correct anomalous data and staff began checking a component of the database records against the raw logbook reports. Coding and QA/QC measures prior to 1999 were likely similar to those used from 1999 to present, however, details on these procedures are not available since staff members working on this project prior to 1998 are no longer with SCDNR. Data are not validated in the field and currently no correction factors are used to account for reporting errors via paper submission; however, the online system is built with error messages and constraints to prevent common reporting mistakes and overlaps in the data. Recall periods for logbook records are typically one month or less. However, in the case of delinquent reports, recall periods could be up to several months. The electronic reporting application has already shown a decrease in recall bias.

Through 2022, the charterboat logbook program had logged 238,270 charterboat trips across South Carolina, with red drum being caught in 129,817 individual trips (~54% of all trips). The positive trips reported the capture of 963,786 fish, with 65,778 (7%) harvested and 898,008 released (Figure A3). Note, South Carolina charterboat owners/operators have developed a strong catch-and-release ethic for red drum (and other species) over time, with most captains either requiring or strongly suggesting catch and release for even legal-sized fish since the early 2000s. This has led to a reported release rate increasing from ~70% in the mid-1990s to >95% since the early 2000s across the South Carolina charterboat fleet (Figure A3).

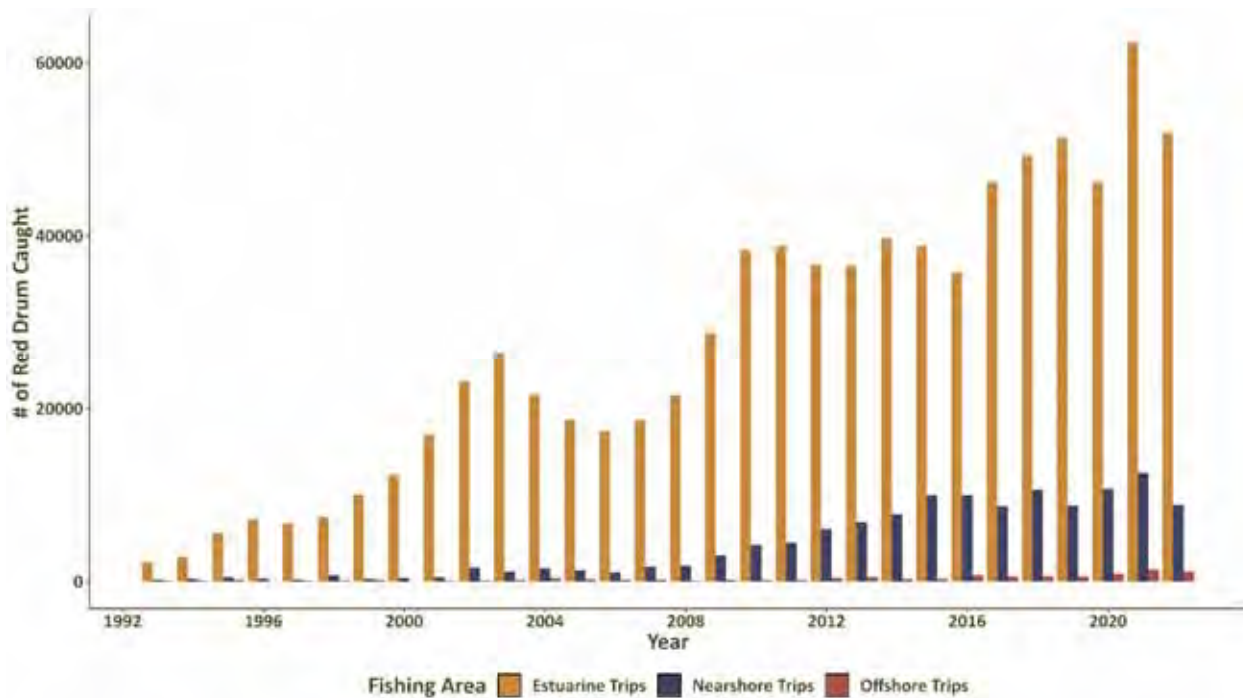
As a census of the catch and effort of the South Carolina charterboat owners/operators, the SCDNR charterboat logbook program has several potential uses in stock assessments of red drum, including as a mechanism to understand temporal changes in fishermen behavior with regards to fishing practices, fishing locations, and within year timing of fishing activities. Cursory investigations of the charterboat logbook data suggests shifts in charterboat owner/operators behavior through time, with an increase in the rate of catch-and-release fishing practices (Figure A3) as well as a shift to more effort to nearshore waters (Figure A4, Figure A5, and Figure A6), which given red drum life history suggests increasing fishing pressure on the adult component of the red drum stock found along coastal South Carolina.



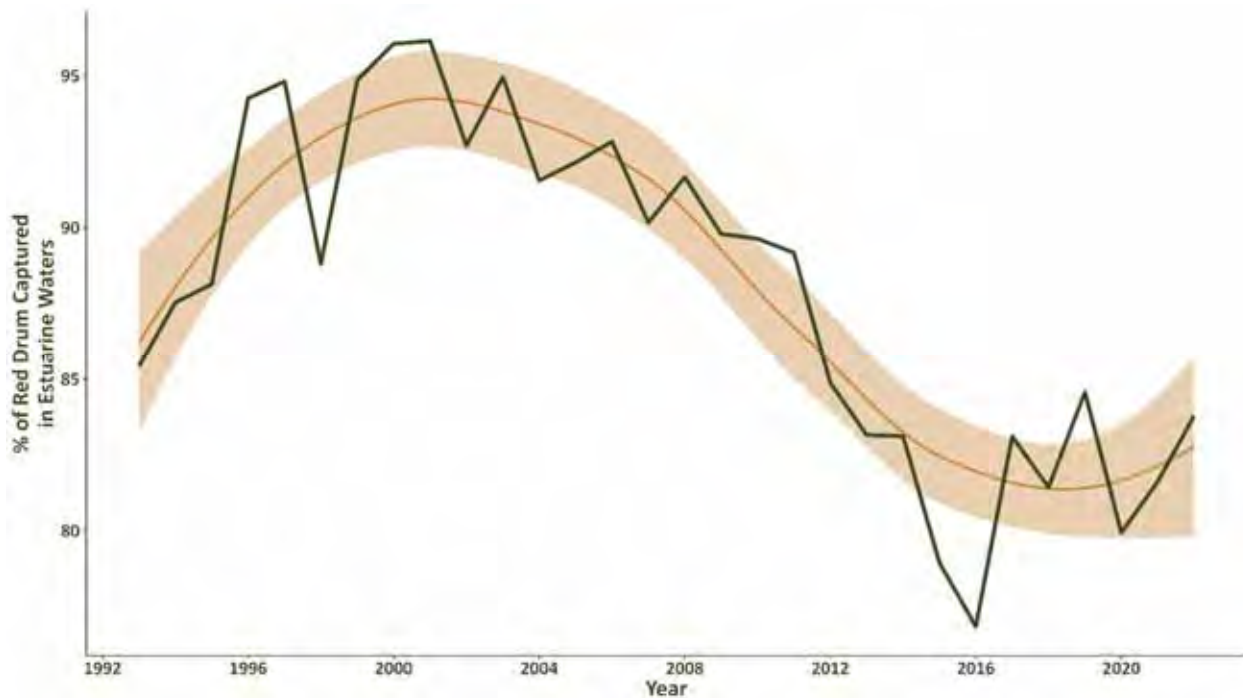
**Figure A3.** Proportion of red drum reported released alive annually by the SCDNR charterboat logbook program. Shown is an annual estimate (solid green line) and a LOESS smoother of annual estimates with 95% confidence interval (orange line and orange shaded region, respectively).



**Figure A4.** Annual trips by geographic area made by charter boat anglers across coastal South Carolina. Note, these are all trips regardless of target species but given 54% of all trips reported capturing at least one red drum and the occurrence of zero catch trips, the general pattern is representative of general shifts in geographic focus of targeting of red drum through time.



**Figure A5.** Number of reported red drum caught annually in estuarine (orange), nearshore (blue), and offshore (red) charterboat trips as reported by the SCDNR charterboat logbook program.

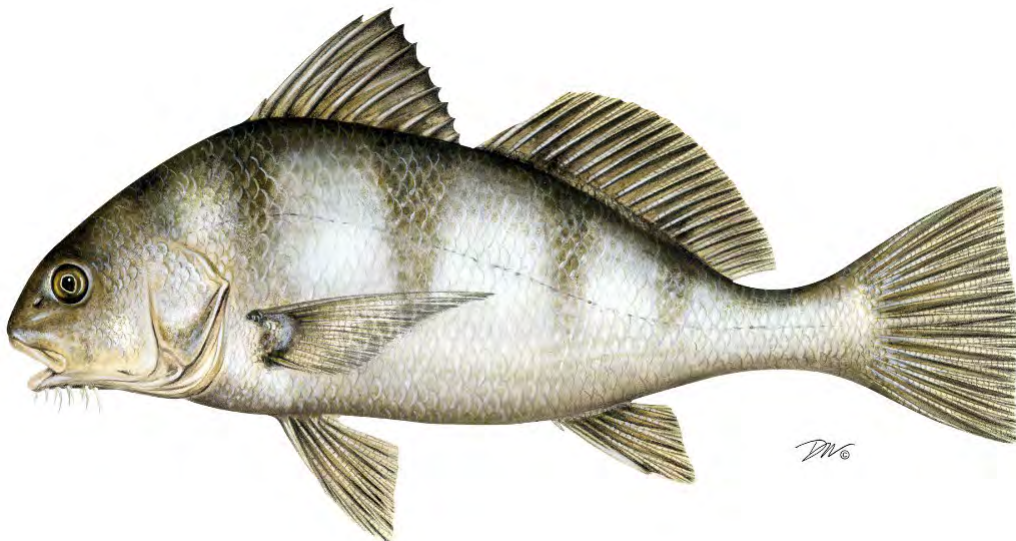


**Figure A6.** Percent of red drum captured annually in estuarine waters as reported by the SCDNR charterboat logbook program. Shown is the annual percentage of fish reported harvest in estuarine waters (green line) as well as a LOESS smoother of annual estimates depicting smoothed annual estimates and 95% confidence intervals of estimates (orange line and orange shaded region, respectively).

**ATLANTIC STATES MARINE FISHERIES COMMISSION**  
**REVIEW OF THE INTERSTATE FISHERY MANAGEMENT PLAN**

**FOR BLACK DRUM**  
***(Pogonias cromis)***

**2023 FISHING YEAR**



Prepared by the Plan Review Team  
Drafted September 2024



*Sustainable and Cooperative Management of Atlantic Coastal Fisheries*

## Table of Contents

I.	Status of the Fishery Management Plan.....	1
II.	Status of the Stocks .....	2
III.	Status of the Fishery.....	2
IV.	Status of Assessment Advice .....	3
V.	Status of Research and Monitoring .....	4
VI.	Status of Management Measures and Issues .....	4
VII.	Implementation of FMP Compliance Requirements for 2023 .....	4
VIII.	Recommendations of the Plan Review Team .....	5
IX.	References .....	5
X.	Figures.....	6
XI.	Tables .....	8



## I. Status of the Fishery Management Plan

<u>Date of FMP Approval:</u>	Original FMP – June 2013
<u>Addendum:</u>	Addendum I – May 2018
<u>Management Areas:</u>	The entire Atlantic coast distribution of the resource from New Jersey through the east coast of Florida
<u>Active Boards/Committees:</u>	Sciaenids Management Board; Black Drum Technical Committee; Plan Review Team; South Atlantic Species Advisory Panel

The Atlantic States Marine Fisheries Commission (ASMFC) adopted an [interstate Fishery Management Plan \(FMP\) for Black Drum in 2013](#). Prior to the FMP, management was state-specific, from no regulations in North Carolina to various combinations of size limits, possession limits, commercial trip limits, and/or annual commercial quotas from New Jersey to Florida. While the Maryland portion of the Chesapeake Bay was closed to commercial fishing in 1998, it was reopened in 2019 via Addendum 1 which was approved in 2018.

The FMP requires all states with a declared interest in the species to have established a maximum possession limit and minimum size limit of at least 12 inches total length (TL) by January 1, 2014, and to have increased the minimum size limit to at least 14 inches TL by January 1, 2016. The FMP also includes a management framework to adaptively respond to future concerns or changes in the fishery or population.

There are four plan objectives:

- Provide a flexible management system to address future changes in resource abundance, scientific information, and fishing patterns among user groups or area.
- Promote cooperative collection of biological, economic, and sociological data required to effectively monitor and assess the status of the black drum resource and evaluate management efforts.
- Manage the black drum fishery to protect both young individuals and established breeding stock.
- Develop research priorities that will further refine the black drum management program to maximize the biological, social, and economic benefits derived from the black drum population.

The management unit for black drum under the FMP is defined as the range of the species within U.S. waters of the northwest Atlantic Ocean, from the estuaries eastward to the offshore boundaries of the Exclusive Economic Zone (EEZ).

In 2018, [Addendum I](#) allowed Maryland to reopen their commercial fishery in the Chesapeake Bay, starting in the 2019 fishing year (ASMFC 2018). Prior to this addendum, a commercial moratorium

was in place for these waters due to the FMP's requirement that states maintain measures in place at the time of the FMP's approval.

## **II. Status of the Stocks**

The most recent coastwide benchmark stock assessment for black drum, which incorporated data through 2020, was accepted in 2023 by the Sciaenids Management Board for management use. Based on assessment results, the black drum stock is not overfished and not experiencing overfishing. Management action was not taken because there are no major concerns with the stock.

The assessment model, JABBA-Select, uses recreational CPUE as an index of abundance, total fishery removals (commercial landings, recreational harvest, and recreational dead discards), life history information, and selectivity information to estimate black drum spawning biomass and exploitation (i.e., the proportion of stock biomass removed by fishing), as well as their associated thresholds. The assessment model estimated increasing spawning biomass, which has remained above the spawning biomass threshold throughout the time series (Figure 1). Exploitation has remained below the exploitation threshold throughout the time series. Exploitation was estimated to be relatively high in the mid-1980s, followed by lower levels throughout the 1990s. Exploitation increased around 2000 and remained at a higher, stable level throughout the remainder of the time series. Overall, black drum remains a data poor stock and the assessment acknowledges a relatively high level of uncertainty in available data sets and population estimates, although there is greater certainty in qualitative stock status determinations.

Due to data limitations and assessment uncertainty, a suite of indicators from black drum data sets developed as part of this assessment will be used to annually monitor the stock for any concerning trends and identify the need for an expedited stock assessment. Indicators include eight indices of abundance, one index of range expansion, and six indices of fishery characteristics (i.e., regional catch time series). The assessment reviewed the indicators through 2020. The indicators show increased fishery removals in the last twenty years and less frequent large recruitment events in the Mid-Atlantic in the last ten years. There are no clear indications of a declining trend in abundance from abundance indicators, but there is a declining trend in the final two years of the recreational releases time series that may be reflective of abundance in addition to other factors. There is some indication of northern range expansion. Overall, stock indicators did not appear negative.

After the assessment was complete, the indicators were updated with data through 2022. Overall, indicators show mixed signs of stability and declines since the assessment. Despite some observed declines in a few of the indicators, in each case the two additional years of data were still within the historical range of that indicator. The TC did not express concern at this time and recommended no changes to the current black drum stock assessment schedule, but to continue to closely monitor the indicators. The Board agreed with the TC's recommendations.

## **III. Status of the Fishery**

Total black drum landings from New Jersey through the east coast of Florida are estimated at 5.5 million pounds in 2023, a 6% increase from total harvest in 2022 (Tables 2 and 3; Figure 2). The 2023 harvest is slightly below the previous ten-year (2013-2022) average. The commercial and recreational fisheries harvested 6% and 94% of the 2023 total, respectively.

Commercial landings of black drum in 2023 spanned from New York through Florida. Although landings from outside the management unit (i.e., north of New Jersey) were less than 1% of the coastwide total, commercial landings in states north of the management unit have increased marginally and become more frequent in the last 10-15 years; black drum have been observed spawning in areas northward of Great Bay, NJ. Coastwide commercial landings show no particular temporal trends, ranging from approximately 82,000 pounds in 1985 to 556,000 pounds in 2002 annually since 1981 (Figure 2). Black drum commercial landings in 2023 were 347,506 pounds, a 42% increase from 2022. North Carolina led commercial harvest with 69% of the landings, followed by Virginia with 21% (Table 2).

Recreational harvest of black drum peaked by weight in 2008 at 10.7 million pounds (Table 3) and by numbers of fish in 2003 at 2.9 million (Table 4). Overall, landings have ranged between 650 thousand pounds in 1988 and 10.7 million pounds in 2008, and numbers of fish have fluctuated between 260,000 in 1989 and 2.9 million fish in 2003 (Figures 3 and 4).

The 2023 recreational harvest (1.2 million fish or 5.2 million pounds) represents a 46% increase in numbers and a 5% increase in pounds from 2022. Florida anglers landed the largest share of the coastwide recreational harvest in numbers (60%), followed by North Carolina (19%). No recreational harvest was estimated in New Jersey in 2023, the first time since 2000.

Since the beginning of the time series (1981), recreational anglers have released increasing percentages of black drum, with percentages of fish released exceeding 70% seven times in the past ten years. In 2023, 69% (2.7 million fish) of the recreational catch was released (Figure 3; Table 5). It is worth noting that release rates increased substantially after 2013, when the FMP established minimum sizes in every state and required that undersized drum be released for the first time. Recent high release rates can be attributed to these measures, as well as encouragement of catch and release practices.

#### **IV. Status of Assessment Advice**

Current stock status information comes from the 2023 benchmark stock assessment (ASMFC 2023) completed by the ASMFC Black Drum Stock Assessment Subcommittee and Technical Committee, peer reviewed by an independent panel of experts, and approved by the Sciaenids Management Board for use in management decisions. It has a terminal year of 2020.

The [assessment report](#) outlines several data and research needs that would improve the next benchmark assessment, such as the need for a fishery-independent adult survey and associated biological data, expansion of current tagging programs, and increased biological sampling in commercial and recreational fisheries.

The favorable stock status estimates from the 2023 benchmark stock assessment indicate that no immediate management action is needed. However, black drum remains a data-poor stock and the assessment acknowledges a relatively high level of uncertainty in available data sets and quantitative population estimates despite greater certainty in qualitative estimates of stock status (i.e., overfished vs. not overfished and overfishing occurring vs. overfishing not occurring). Due to this uncertainty, the stock assessment recommends that stock indicators as established in the Black Drum Benchmark Stock Assessment and Peer Review Report be reviewed annually by the Sciaenids Management Board to closely monitor the stock for any concerning trends between stock assessments. It is recommended that the next benchmark assessment should be conducted in five years.

## **V. Status of Research and Monitoring**

There are no monitoring or research programs required annually of the states except for the submission of a compliance report. The following fishery-dependent (other than catch and effort data) and fishery-independent monitoring programs were reported in the 2024 reports. Delaware, Maryland, Virginia, North Carolina, South Carolina, Georgia, Florida, and National Marine Fisheries Service have fishery-dependent monitoring for black drum. States that encounter fish through fishery-independent monitoring include New Jersey, Delaware, Maryland, North Carolina, South Carolina, Georgia, and Florida.

## **VI. Status of Management Measures and Issues**

### *Fishery Management Plan*

The Black Drum FMP required all states with a declared interest in the species to have established a maximum possession limit and minimum size limit of at least 12 inches TL by January 1, 2014, and to have increased the minimum size limit to no less than 14 inches TL by January 1, 2016.

### *De Minimis*

The black drum FMP allows states to request *de minimis* status if, for the preceding three years for which data are available, their average combined commercial and recreational landings (by weight) constitute less than 1% of the average coastwide commercial and recreational landings for the same three-year period. A state that qualifies for *de minimis* will qualify for exemption in both their commercial and recreational fisheries.

### *De Minimis Requests*

No state requested *de minimis* status through the annual reporting process.

### *Recent Changes to State Management*

None in 2023.

## **VII. Implementation of FMP Compliance Requirements for 2023**

The PRT found no inconsistencies between state compliance reports and requirements of the Fishery Management Plan.

## **VIII. Recommendations of the Plan Review Team**

Research recommendations can be found in the [2023 Black Drum Benchmark Stock Assessment and Peer Review Report](#).

### Management and Regulatory Recommendations

- Begin or continue biological sampling to collect age and size composition from both recreational and commercial fisheries as well as fecundity data. Data gaps include size and age of discards, catch and release mortality, age and size-specific fecundity, spawning frequency, and spawning behaviors by region.
- Continue and expand current tagging programs to obtain mortality and growth information and movement at size data, and consider conducting a high reward tagging program to obtain improved return rate estimates. Tagging studies that utilize implanted radio tracking tags compatible with coastal tracking arrays along the Atlantic coast in order to track movement and migration of adults and juveniles would also help fill the data needs.

## **IX. References**

ASMFC. 2013. Interstate Fishery Management Plan for Black Drum. Arlington, VA. 72 p.

ASMFC. 2015. Black Drum Stock Assessment for Peer Review. Atlantic States Marine Fisheries Commission, Stock Assessment Report. 352 p.

ASMFC. 2018. Addendum I to the Black Drum Interstate Fishery Management Plan. Arlington, VA. 4 p.

ASMFC. 2023. [Black Drum Benchmark Stock Assessment and Peer Review Report](#). Atlantic States Marine Fisheries Commission. Arlington, VA. 299 p.

Winker, H., F. Carvalho, J.T. Thorson, L.T. Kell, D. Parker, M. Kapur, R. Sharma, A.J. Booth, and S.E. Kerwath. 2020. JABBA-Select: Incorporating life history and fisheries' selectivity into surplus production models. Fisheries Research 222.

X. Figures

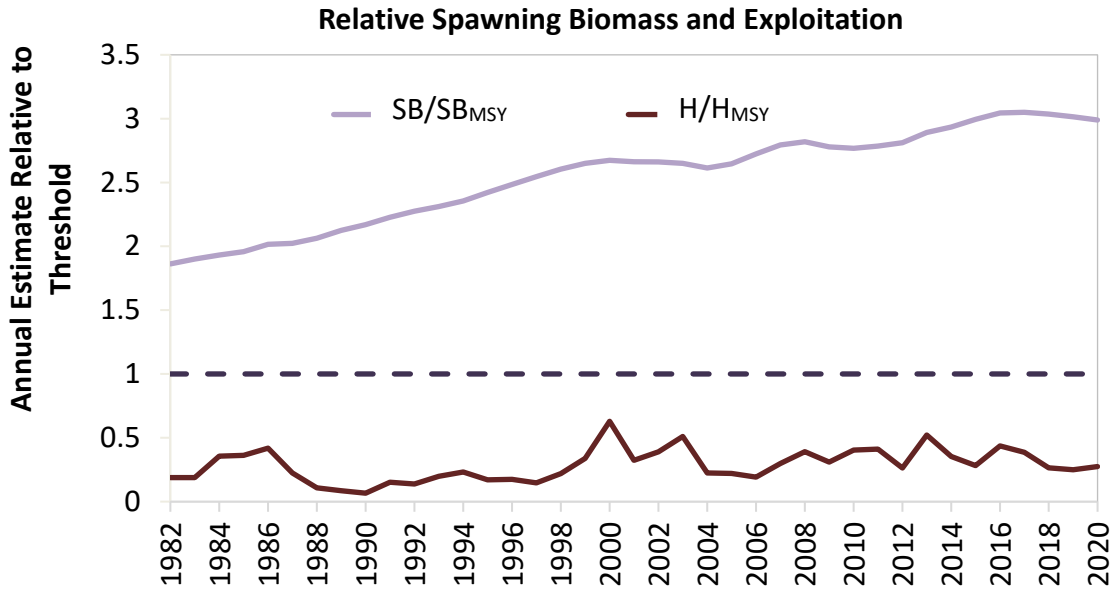


Figure 1. JABBA-Select annual estimates of spawning biomass ( $SB/SB_{MSY}$ ) and exploitation ( $H/H_{MSY}$ ) relative to the threshold (dashed line), from 1982-2020 (Source: ASMFC 2023).

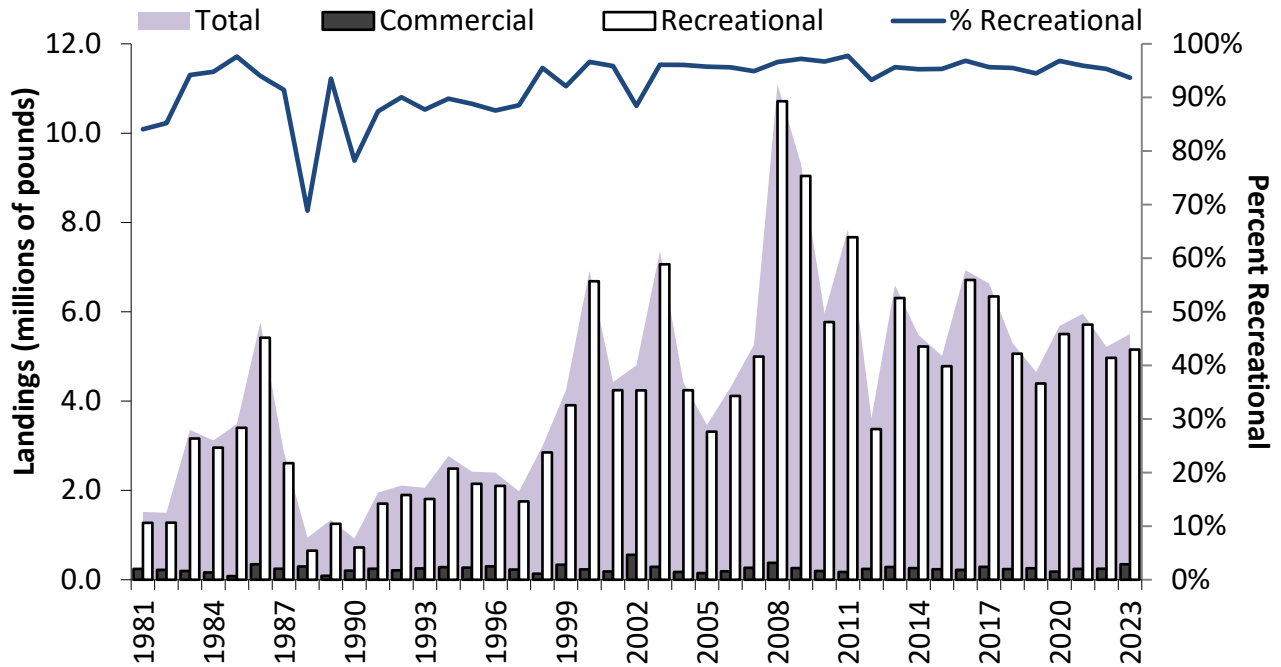
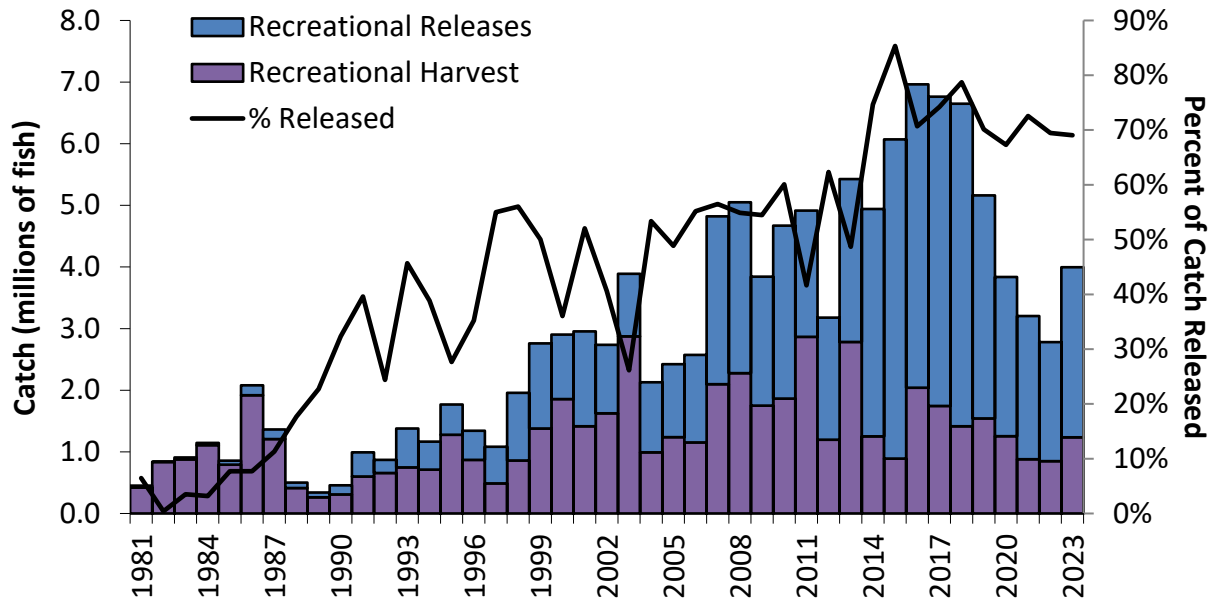


Figure 2. Commercial and recreational landings (pounds) of black drum, 1981-2023. See Tables 2 and 3 for values and data sources.



**Figure 3. Recreational catch (harvest and alive releases) of black drum (numbers) and the proportion of catch that is released, 1981-2023. See Tables 4 and 5 for values and data sources.**

**XI. Tables**

**Table 1. Black drum regulations for 2023.** The states of New Jersey through Florida are required to meet the requirements in the FMP. All size limits are total length.

State	Recreational		Commercial			Notes
	Size limit	Bag limit	Size limit	Trip Limit	Annual Quota	
ME - NY	-	-	-	-	-	
NJ	16" min	3/person/day	16" min	10,000 lbs	65,000 lbs	
DE	16" min	3/person/day	16" min	10,000 lbs	65,000 lbs	
MD	16" min	1/person/day 6/vessel	16" min (ATL) 28" min (Bay)	10/vessel/day (Bay)	1,500 lbs (ATL)	
PRFC	16" min	1/person/day	16" min	1 fish possession		
VA	16" min	1/person/day	16" min	1/person/day*	120,000 lbs	*without Black Drum Harvesting and Selling Permit
NC	14" min - 25" max; 1 fish > 25" may be retained	10/person/day	14" min - 25" max; 1 fish > 25" may be retained	500 lbs/trip		
SC	14" min - 27" max	5/person/day	14" min - 27" max	5/person/day		Commercial fishery primarily bycatch
GA	14" min	15/person/day	14" min	15/person/day		
FL	14" min - 24" max; 1 fish >24" may be retained	5/person/day	14" min - 24" max	500 lbs/day		



**Table 2. Commercial landings (pounds) of black drum by state, 2014-2023.** (Totals include coastwide landings outside of the management area, NJ-FL. Sources: 2024 state compliance reports for 2023 fishing year; for years prior to 2023, personal communication with ACCSP, Arlington, VA)

Year	NJ	DE	MD	PRFC	VA
2014	9,270	C	C	C	88,402
2015	6,478	39,282	C	C	87,011
2016	2,210	49,109	C	C	49,832
2017	21,248	699	423	C	42,695
2018	C	32,375	734	C	76,337
2019	C	6,030	8,025	C	129,556
2020	C	C	4,767	C	50,318
2021	1,057	C	821	0	63,340
2022	C	C	2,462	C	51,087
2023	C	C	2,097	C	71,855
	NC	SC	GA	FL	Total
2014	51,217	C	C	91,587	259,650
2015	51,073	C	C	50,477	234,727
2016	90,715	C	C	26,978	219,350
2017	182,882	C	C	41,280	289,431
2018	109,757	C	C	19,465	239,124
2019	80,036	C	C	21,954	256,051
2020	98,118	C	C	26,895	188,410
2021	131,724	C	C	45,300	243,278
2022	144,339	C	0	42,563	244,198
2023	240,814	C	0	30,486	347,506

C: Confidential landings

**Table 3. Recreational harvest (pounds) of black drum by state and coastwide average weight, 2014-2023.** (Sources: 2024 state compliance reports for 2023 fishing year; for years prior to 2023, personal communication with NOAA Fisheries, Fisheries Statistics Division)

<b>Year</b>	<b>NJ</b>	<b>DE</b>	<b>MD</b>	<b>VA</b>	<b>NC</b>
<b>2014</b>	11,476	22,070	18,684	97,043	230,834
<b>2015</b>	443,907	16,992	16,575	25,216	780,876
<b>2016</b>	159,589	2,180	8,924	77,672	1,322,547
<b>2017</b>	406,068	22,998	3,001	81,275	856,081
<b>2018</b>	814,965	179,071	53,599	29,120	428,273
<b>2019</b>	172,735	8,117	59,912	101,535	404,452
<b>2020</b>	535,249	90,950	53,825	251,724	612,932
<b>2021</b>	1,851	14,659	80,563	345,108	359,481
<b>2022</b>	190,561	1,412	19,580	18,130	1,710,528
<b>2023</b>	0	115	10,697	351,895	973,869
	<b>SC</b>	<b>GA</b>	<b>FL</b>		<b>Total</b>
<b>2014</b>	238,616	249,118	4,353,686		5,221,527
<b>2015</b>	82,484	88,698	3,325,410		4,780,158
<b>2016</b>	623,449	226,558	4,292,398		6,713,317
<b>2017</b>	681,976	187,698	4,105,686		6,344,783
<b>2018</b>	652,179	392,380	2,511,235		5,060,822
<b>2019</b>	899,976	557,714	2,191,274		4,395,715
<b>2020</b>	493,001	298,894	3,163,767		5,500,342
<b>2021</b>	345,225	178,803	4,386,989		5,712,731
<b>2022</b>	319,324	295,514	2,395,463		4,969,409
<b>2023</b>	433,013	285,898	3,097,376		5,152,863

**Table 4. Recreational harvest (numbers) of black drum by state, 2014-2023.** (Sources: 2024 state compliance reports for 2023 fishing year; for years prior to 2023, personal communication with NOAA Fisheries, Fisheries Statistics Division)

<b>Year</b>	<b>NJ</b>	<b>DE</b>	<b>MD</b>	<b>VA</b>	<b>NC</b>
<b>2014</b>	482	1,052	1,690	10,676	109,307
<b>2015</b>	10,793	462	1,091	1,600	276,126
<b>2016</b>	6,008	138	250	5,807	459,078
<b>2017</b>	18,435	1,214	828	16,700	355,544
<b>2018</b>	40,153	9,211	1,262	3,721	134,624
<b>2019</b>	7,506	931	4,897	6,600	156,401
<b>2020</b>	27,594	5,207	14,092	17,000	213,320
<b>2021</b>	382	1,115	2,724	17,607	121,454
<b>2022</b>	8,594	54	2,945	1,231	264,634
<b>2023</b>	0	7	1,202	18,587	348,374
	<b>SC</b>	<b>GA</b>	<b>FL</b>		<b>Total</b>
<b>2014</b>	96,967	47,807	983,582		1,251,563
<b>2015</b>	37,186	48,229	514,606		890,093
<b>2016</b>	256,158	96,351	1,217,913		2,041,703
<b>2017</b>	241,832	64,240	1,044,752		1,743,545
<b>2018</b>	185,648	114,263	925,794		1,414,676
<b>2019</b>	344,933	265,364	755,638		1,542,270
<b>2020</b>	198,239	100,973	678,484		1,254,909
<b>2021</b>	92,232	65,955	577,906		879,468
<b>2022</b>	92,122	111,492	367,912		849,406
<b>2023</b>	142,438	67,430	657,786		1,235,824

**Table 5. Recreational alive releases (numbers) of black drum by state, 2014-2023.** (Sources: 2024 state compliance reports for 2023 fishing year; for years prior to 2023, personal communication with NOAA Fisheries, Fisheries Statistics Division)

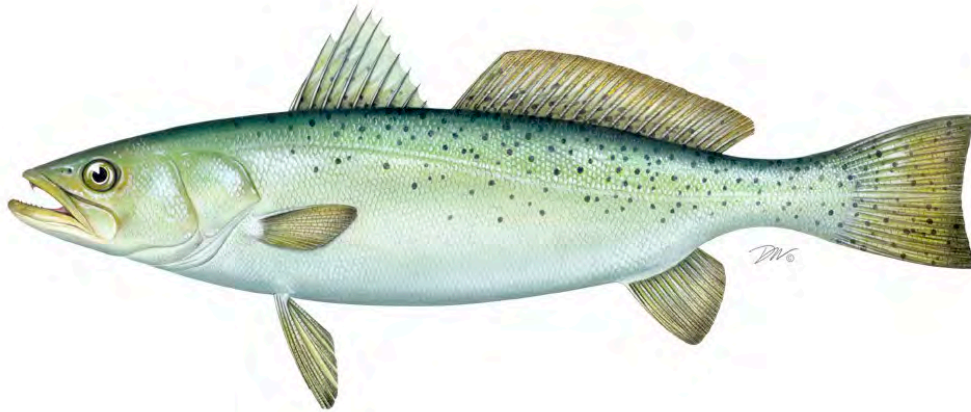
<b>Year</b>	<b>NJ</b>	<b>DE</b>	<b>MD</b>	<b>VA</b>	<b>NC</b>
<b>2014</b>	37,364	11,243	0	269,648	1,964,749
<b>2015</b>	545,613	17,109	25,115	164,322	1,791,758
<b>2016</b>	9,399	361	114	46,494	2,530,596
<b>2017</b>	111,739	3,689	2,809	137,987	2,336,352
<b>2018</b>	51,148	15,249	27,849	169,204	1,450,855
<b>2019</b>	1,953	29,878	6,346	151,074	756,749
<b>2020</b>	10,474	8,301	1,997	142,394	704,357
<b>2021</b>	41,807	19,517	92,542	168,208	681,121
<b>2022</b>	59,745	7,064	10,268	44,621	647,304
<b>2023</b>	18,252	29,231	3,908	71,964	591,980
	<b>SC</b>	<b>GA</b>	<b>FL</b>		<b>Total</b>
<b>2014</b>	335,600	21,581	1,047,833		3,688,018
<b>2015</b>	1,483,956	55,773	1,096,185		5,179,831
<b>2016</b>	1,268,667	54,266	1,012,670		4,922,567
<b>2017</b>	692,616	85,365	1,648,030		5,018,587
<b>2018</b>	1,087,536	167,974	2,265,550		5,235,365
<b>2019</b>	998,869	339,599	1,333,745		3,618,213
<b>2020</b>	678,836	239,371	797,425		2,583,155
<b>2021</b>	304,632	94,097	922,962		2,324,886
<b>2022</b>	647,853	168,502	345,227		1,930,584
<b>2023</b>	791,140	291,336	960,813		2,758,624

**ATLANTIC STATES MARINE FISHERIES COMMISSION**  
**REVIEW OF THE INTERSTATE FISHERY MANAGEMENT PLAN**

**FOR**

**SPOTTED SEATROUT**  
*(Cynoscion nebulosus)*

**2023 FISHING YEAR**



Prepared by the Plan Review Team  
Drafted September 2024



*Sustainable and Cooperative Management of Atlantic Coastal Fisheries*

## Table of Contents

I.	Status of the Fishery Management Plan.....	1
II.	Status of the Stock .....	2
III.	Status of the Fishery.....	3
IV.	Status of Assessment Advice .....	4
V.	Status of Research and Monitoring .....	5
VI.	Status of Management Measures and Issues .....	5
VII.	Implementation of FMP Compliance Requirements for 2023 .....	5
VIII.	Recommendations of Plan Review Team .....	5
IX.	References .....	6
X.	Figures.....	8

## I. Status of the Fishery Management Plan

<u>Date of FMP Approval:</u>	Original FMP – October 1984
<u>Amendments:</u>	Amendment 1 – November 1991 Omnibus Amendment to Spanish Mackerel, Spot, and Spotted Seatrout -- August 2011
<u>Management Area:</u>	The Atlantic coast distribution of the resource from Maryland through the east coast of Florida
<u>Active Boards/Committees:</u>	Sciaenids Management Board; Spotted Seatrout Plan Review Team; South Atlantic Species Advisory Panel

The Atlantic States Marine Fisheries Commission (ASMFC) adopted the [Fishery Management Plan \(FMP\)](#) for spotted seatrout in 1984. The ISFMP Policy Board approved Amendment 1 to the FMP in November 1991. In August 2011, the South Atlantic State/Federal Management Board approved the Omnibus Amendment to the Spanish Mackerel, Spot, and Spotted Seatrout FMPs, bringing the Spotted Seatrout FMP under the authority of the Atlantic Coastal Fisheries Cooperative Management Act (Act, 1993) and the ASMFC Interstate Fishery Management Plan Charter (1995). The management unit is comprised of the states of Maryland through Florida.

The goal of the management plan is "to perpetuate the spotted seatrout resource in fishable abundance throughout its range and generate the greatest possible economic and social benefits from its harvest and utilization over time." Plan objectives include:

1. Attain optimum yield over time.
2. Maintain a spawning potential ratio of at least 20% to minimize the possibility of recruitment failure.
3. Promote conservation of the stocks to reduce inter-annual variation in availability and to increase yield per recruit.
4. Promote collection of economic, social, and biological data required to effectively monitor and assess management efforts relative to the overall goal.
5. Promote research that improves understanding of the biology and fisheries of spotted seatrout.
6. Promote harmonious use of the resource among various components of the fishery through coordination of management efforts among the various political entities having jurisdiction over the spotted seatrout resource.
7. Promote determination and adoption of standards of environmental quality and provide habitat protection necessary for the maximum natural protection of spotted seatrout.

The [Omnibus Amendment](#) added the following objectives to support compliance under the Act:

1. Manage the spotted seatrout fishery by restricting catch to mature individuals.
2. Manage the spotted seatrout stock to maintain sufficiently high spawning stock biomass.
3. Develop research priorities that will further refine the spotted seatrout management program to maximize the biological, social, and economic benefits derived from the population.

Management measures include a minimum size limit of 12 inches in total length (TL), with comparable mesh size regulations in directed fisheries, and data collection for stock assessments and monitoring of the fishery. All states with a declared interest in spotted seatrout (NJ-FL) have implemented, at a minimum, the recommended minimum size limit. In addition, each state has either initiated spotted seatrout data collection programs or modified other programs to collect improved catch and effort data. Table 1 provides the states' recreational and commercial regulations for spotted seatrout in 2023.

## **II. Status of the Stock**

A coastwide stock assessment of spotted seatrout has not been conducted, given the largely non-migratory nature of the species and the lack of data on migration where it does occur. Instead, state-specific age-structured analyses of local stocks have been performed by several states. These stock assessments provide estimates of static spawning potential ratio (SPR), a measure of the effect of fishing pressure on the relative spawning power of the female stock. The FMP recommends a goal of 20% SPR. South Carolina and Georgia have adopted this goal while North Carolina and Florida have established a 30% and 35% SPR goal, respectively.

A benchmark stock assessment for spotted seatrout in North Carolina and Virginia waters was completed and approved to use for management in late 2022 (<https://www.deq.nc.gov/marine-fisheries/fisheries-management/spotted-seatrout/2022-spotted-seatrout-stock-assessment/open>; NCDMF 2022). The assessment indicated the spotted seatrout stock in North Carolina and Virginia waters was not overfished with spawning stock biomass (SSB) above  $SSB_{35\%}$ , but overfishing was occurring. A review of the North Carolina FMP is currently underway. Amendment 1 to the North Carolina Spotted Seatrout FMP will focus on management to end overfishing and ensure sustainable harvest.

The South Carolina Department of Natural Resources packaged several state-specific assessments into a report in 2001, though these were not peer reviewed. The initial assessment covering 1986-1992 indicated female SPR was just above the 20% goal in the terminal year (Zhao and Wenner 2001), leading to a minimum size limit increase and a creel limit reduction. A more recent assessment was conducted for the period 1981-2004 (de Silva, Draft 2005). Two modeling approaches were used, and both models indicated the current SSB is below the requirement to maintain 20% SPR.

Florida completed a new statewide assessment in 2018, which in 2019 was updated with data through 2017 (<https://myfwc.com/media/26731/seatrout-assessment-summary-2019.pdf>;



Addis et al. 2018; Muller and Addis 2019). They assessed the status of spotted seatrout populations among management regions in Florida waters using an integrated statistical catch-at-age model, Stock Synthesis, as the primary modeling platform. Spotted seatrout population dynamics were described for the period 1950-2017 utilizing available information on catch, effort, relative abundance, and size/age composition. For the Northeast (Nassau through Flagler counties) and Southeast (Volusia through Miami-Dade counties) management regions along Florida's Atlantic coast, the regional base SS model estimates of current transitional spawning potential ratios ( $tSPR_{Current}$ , geometric mean for 2015-2017) are 31% in the northeast, and 34% in the southeast region. The  $tSPR_{Current}$  values for the two Atlantic coast regions were found to be below the Commission's 35%  $tSPR_{Current}$  management target. These assessment results led to changes in spotted seatrout regulations in Florida, including decreasing bag limits and modifying the slot size limit (Table 1). Work on a new benchmark stock assessment is underway in Florida, and is scheduled to be completed in by the end of 2024.

### **III. Status of the Fishery**

Spotted seatrout are typically caught both commercially and recreationally from Delaware through the east coast of Florida. In South Carolina, spotted seatrout are declared a gamefish and can only be taken by recreational means. Landings from states north of Delaware are minimal and/or inconsistent from year to year. In 2023, landings ranged as far north as Connecticut. State catch estimates in this section include those in the management area only (NJ-FL), but coastwide totals include the entire Atlantic coast. Total recreational landings have surpassed total commercial landings every year since recreational landings were first recorded in 1981 (Figure 1). Spotted seatrout, particularly those found from Virginia through South Carolina, are susceptible to cold stuns that result in sporadic, high winter mortality, which can lead to sudden declines in harvest. The last cold stun occurred in 2018, prompting in-season changes to management in affected states.

#### *Commercial Fishery*

Commercial harvest statistics were obtained from the Atlantic Coastal Cooperative Statistics Program (ACCSP) for years prior to 2023 and from state compliance reports for 2023. Atlantic coast commercial landings (1950-2023) range from 157,000 pounds in 2011 to 2.3 million pounds in 1952 (Figure 1). Historically, commercial landings primarily came from Virginia, North Carolina, and Florida, with Maryland, South Carolina, Georgia, and occasional landings from Delaware and north accounting for a small portion. From 1950 to 1976, annual commercial landings averaged 1.3 million pounds, followed by a decline due to increased regulations and possible declines in abundance. Significant changes to regulations include the 1987 designation of spotted seatrout as a gamefish in South Carolina, and the 1995 prohibition on the use of entangling nets in Florida's coastal waters. From 2014 to 2023, commercial landings averaged approximately 453,178 pounds. In 2023, commercial landings totaled 522,290 pounds, a 31% decrease from a peak in 2021 (Table 2). North Carolina, Virginia, and Florida accounted for 83%, 14%, and 2% of the total commercial landings, respectively.

### *Recreational Fishery*

Recreational harvest statistics were obtained from the Marine Recreational Information Program (MRIP) for years prior to 2023 and from state compliance reports for 2023. Over the last 41 years, recreational catch of spotted seatrout (kept and released) has shown an upward trend, increasing from 4.3 million fish in 1981 to 31.2 million fish in 2018 and had remained high through 2022. In 2023, recreational catch declined by 37% from the previous year, to 16.2 million fish, the lowest recreational catch since 2008 (Figure 2). Recreational harvest has remained without trend throughout the time series. From 2019 through 2022, recreational harvest was relatively high, averaging 6.6 million pounds or 3.9 million fish. However, recreational harvest in 2023 declined by approximately 40% from this average, to 4.3 million pounds or 2.4 million fish (Tables 3 and 4), with North Carolina (41%), Georgia (20%), and Virginia (17%) responsible for the largest shares in numbers of fish. Due in part to recreational size and creel limits and closed seasons, as well as the encouragement of catch and release practices, the percentage of caught fish being released has increased throughout the time series, with the 10-year average (2014-2023) at 82%. The percent of fish released in 2023 (85%) was approximately equal to the percent of fish released in 2022 (85%; Figure 2, Table 5). The number of fish released has averaged 18.9 million fish in the last 10 years (2014-2023). In 2023, 13.7 million fish were released, which was a 38% decline from the previous year. Rod and reel is the primary recreational gear, but some spotted seatrout are taken by recreational nets and gigging where these methods are permitted. Most recreational fishing is conducted from private boats and the majority of the catch is taken from nearshore waters.

#### **IV. Status of Assessment Advice**

A coastwide stock assessment of spotted seatrout has not been conducted and the Plan Review Team (PRT) does not recommend that one be completed due to the life history of the fish and the availability of data. Several states have performed age-structured analyses on local stocks, and recent assessments provide divergent trends on the status of the species. The 2005 stock assessment in South Carolina indicated an increasing population trend but a status level that is still below target spawning stock biomass levels (de Silva 2005).

The 2022 North Carolina and Virginia stock assessment indicated overfishing was occurring but that the stock was not overfished (NCDMF 2022). The stock assessment model was a novel, size structured model with winter and non-winter seasonal time-steps. Additionally, the model allowed winter natural mortality (M) to vary year to year in order to capture the signature of increased winter M from cold stuns and predicted high or rising M in most years with documented cold stuns.

In the 2019 Florida stock assessment update, the regional base SS model estimated current transitional spawning potential ratios of 31% in the Northeast management region, and 34% in the Southeast management region on Florida's Atlantic coast. The transitional spawning potential ratio for the spotted seatrout stock in northeast Florida was below the Commission's 35%  $tSPR_{Current}$  management target and in southeast Florida, it was just below or at the management target (Muller and Addis 2019).

The PRT supports the continuation of state-specific assessments, yet recognizes the difficulty most states face to attain sufficient data of assessment quality and personnel who can perform the necessary modeling exercises. The lack of biological and fisheries data for effective assessment and management of the resource was recognized in the 1984 FMP and continues to be a hindrance. Some states are increasing their collection of biological and fisheries data, which will provide insight on stock status over time.

## **V. Status of Research and Monitoring**

In addition to commercial and recreational fishery-dependent data collected and/or compiled through the NMFS Fisheries Statistics Division, some states have implemented fishery-independent or additional fishery-dependent monitoring programs. States currently conducting fishery dependent sampling include Delaware, Maryland, Virginia, North Carolina, South Carolina, Georgia, and Florida. Delaware, Maryland, North Carolina, South Carolina, Georgia, and Florida currently conduct fishery independent surveys for spotted seatrout or run surveys encountering spotted seatrout. Virginia, North Carolina, and South Carolina conduct aging, and in 2023 the NCDMF aging lab aged a total of 1,045 spotted seatrout by otoliths with a maximum age of 8 and a modal age of 1. In 2023, Virginia aged 259 spotted seatrout, with a modal age of 1.

## **VI. Status of Management Measures and Issues**

### ***De Minimis Requests***

A state qualifies for *de minimis* status if its previous three-year average combined commercial and recreational catch is less than 1% of the previous three-year average coastwide combined commercial and recreational catch. Those states that qualify for *de minimis* are not required to implement any monitoring requirements, as none are included in the plan.

The states of Delaware and New Jersey request continuation of *de minimis* status, and the PRT notes they meet the requirements of *de minimis*.

## **VII. Implementation of FMP Compliance Requirements for 2023**

The PRT found no inconsistencies in relation to the FMP compliance requirements among state compliance reports.

## **VIII. Recommendations of Plan Review Team**

### **Management and Regulatory Recommendations**

- Consider approval of *de minimis* requests by New Jersey and Delaware.

### **Prioritized Research Recommendations**

- The PRT recommends focusing on addressing important missing components to improve state specific stock assessments. Specific focal areas include the development or

improvement of state specific abundance indices, particularly for juvenile abundance indices, research into fecundity and recruitment relationships, and additional research into B2 releases due to a rise in popularity of the catch and release fishery.

- Consider trigger factors to allow for a swift management response to environmental events that have been shown to heavily impact spotted seatrout. An example is a temperature trigger in North Carolina to protect spotted seatrout that have had long-term exposure to cold temperatures. Additional research into links between spotted seatrout population dynamics and life history variability in response to environmental factors such as land use patterns, climate change, etc.

## **IX. References**

- De Silva JA. 2005. Draft. Stock assessment of spotted seatrout, *Cynoscion nebulosus*, in South Carolina with recommendations on the management of the recreational fishery. South Carolina Department of Natural Resources, Marine Research Institute, Charleston (SC).
- Florida Fish and Wildlife Conservation Commission's Fish and Wildlife Research Institute. 2013. Species Profile: Spotted Seatrout. In: R.H. McMichael, editor. Fisheries-independent monitoring program, 2012 annual data summary report, St. Petersburg (FL).
- Addis D, Mahmoudi B, O'Hop J, Muller R. 2018. The 2016 stock assessment of Spotted Seatrout, *Cynoscion nebulosus*, in Florida. Florida Fish and Wildlife Conservation Commission's Fish and Wildlife Research Institute, St. Petersburg, (FL).
- Jensen CC. 2009. Stock status of spotted seatrout, *Cynoscion nebulosus*, in North Carolina, 1991-2008. Morehead City (NC): North Carolina Division of Marine Fisheries. 89 p.
- Moravec F, de Buron I, Roumillat WA. 2006. Two new species of Philometra (Nematoda: Philometridae) parasitic in the perciform fish *Cynoscion nebulosus* (Sciaenidae) in the estuaries of South Carolina, USA. *Folia Parasitologica*, 53: 63-70
- Muller, R, and Addis D. 2019. An update assessment of the status of spotted seatrout in Florida waters through 2017. Florida Fish and Wildlife Conservation Commission's Fish and Wildlife Research Institute, St. Petersburg, (FL).
- Murphy MD, Chagaris D, Addis D. 2011. An assessment of the status of spotted seatrout in Florida waters through 2009. Florida Fish and Wildlife Conservation Commission Fish and Wildlife Research Institute. In-House Report 2011-002, St. Petersburg (FL).
- North Carolina Division of Marine Fisheries. 2014. Stock assessment of spotted seatrout, *Cynoscion nebulosus*, in Virginia and North Carolina waters. North Carolina Department of Environment and Natural Resources, Division of Marine Fisheries, Morehead City (NC).

North Carolina Division of Marine Fisheries. 2022. Stock Assessment of Spotted Seatrout, *Cynoscion nebulosus*, in Virginia and North Carolina waters, 1991–2019. North Carolina Division of Marine Fisheries, NCDMF SAP-SAR-2022-02, Morehead City, North Carolina. 137

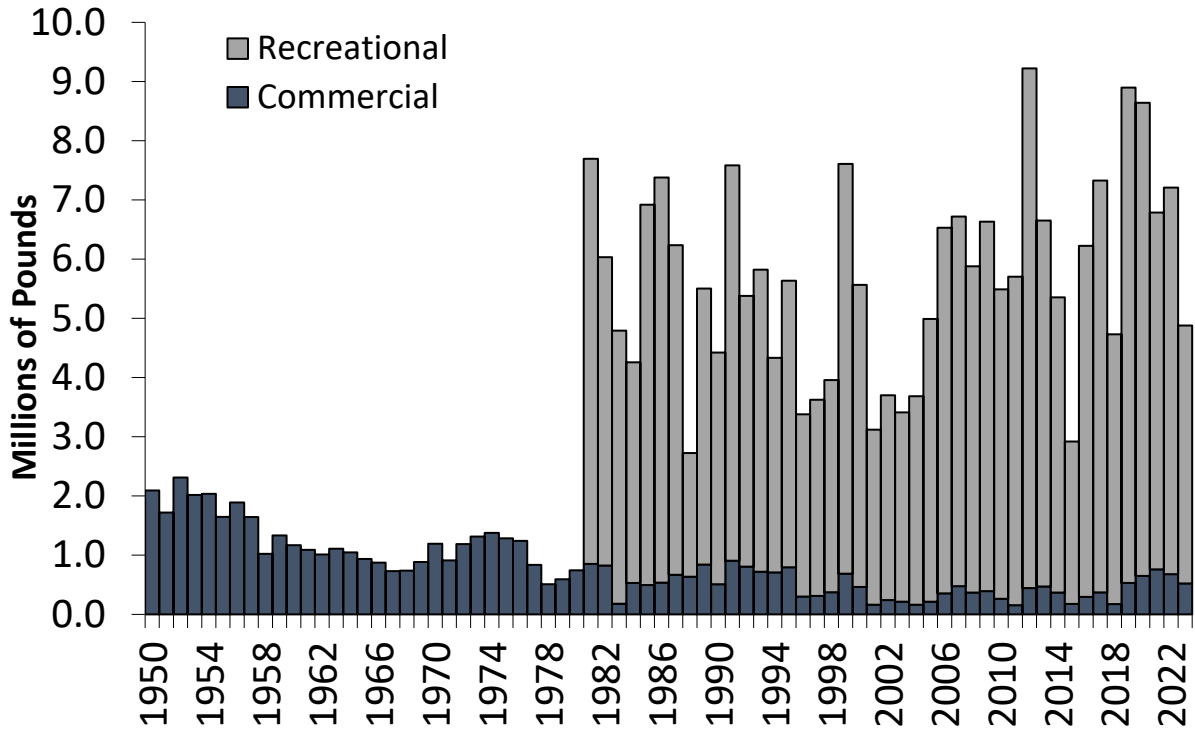
Roumillat WA, Brouwer MC. 2004. Reproductive dynamics of female spotted seatrout (*Cynoscion nebulosus*) in South Carolina. Fisheries Bulletin, 102: 473-487

Zhao B, Burns B. 2001. Stock assessment of the spotted seatrout, *Cynoscion nebulosus*, on the North Carolina coast, 1981-1997. In: South Carolina Department of Natural Resources. Cooperative Research on the Biology and Assessment of Nearshore and Estuarine Fishes along the Southeast Coast of the U.S: Part III. Spotted Seatrout, *Cynoscion nebulosus*. Charleston (SC): SC DNR. Final Report, Grant NA77FF0550.

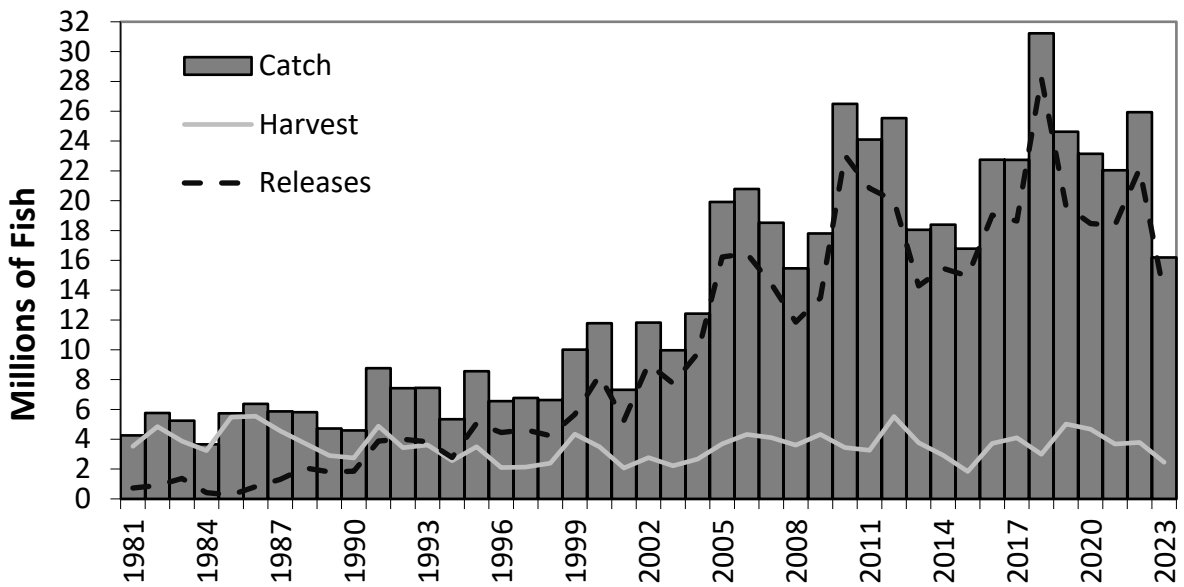
Zhao B, Wenner C. 2001. Stock assessment of the spotted seatrout, *Cynoscion nebulosus*, on the South Carolina coast, 1986-1992. In: South Carolina Department of Natural Resources. Cooperative Research on the Biology and Assessment of Nearshore and Estuarine Fishes along the Southeast Coast of the U.S: Part III. Spotted Seatrout, *Cynoscion nebulosus*. Charleston (SC): SC DNR. Final Report, Grant NA77FF0550.

Zhao B, Wenner C, Nicholson N. 2001. Stock assessment of the spotted seatrout, *Cynoscion nebulosus*, on the Georgia Coast, 1986-1995. In: South Carolina Department of Natural Resources. Cooperative Research on the Biology and Assessment of Nearshore and Estuarine Fishes along the Southeast Coast of the U.S: Part III. Spotted Seatrout, *Cynoscion nebulosus*. Charleston (SC): SC DNR. Final Report, Grant NA77FF0550.

X. Figures



**Figure 1.** Coastwide commercial landings (1950-2023) and recreational landings (1981-2023), in pounds (See Tables 2 and 4 for values and sources). Recreational data not available prior to 1981.



**Figure 2.** Coastwide recreational catch, harvest, and releases (numbers), 1981-2023 (See Tables 3 and 5 for values and sources).

**XI. Tables**

**Table 1.** Summary of state regulations for spotted seatrout in 2023.

State	Recreational	Commercial
New Jersey	13" TL; 1 fish	13" TL; 100 lbs/vessel/day during open seasons 100 lbs bycatch allowance during closed season if equal lbs of other species are also harvested.  Gill net: 3.25 in minimum mesh size; closed season from 5/21-9/2 and 10/20-10/26.  Otter trawl: 3.75 in minimum diamond stretched mesh size or 3.375 in stretched square mesh; closed season 8/1 to 10/12  Pound net: closed season 6/7 to 6/30  Hook and line: must follow recreational bag and size limit
Delaware	12" TL	12" TL
Maryland	14" TL; 4 fish	14" TL. 150 lbs limit per day or trip (whichever is longer). Trawl and gill net mesh size restrictions.
PRFC	14" TL; 10 fish	14" TL
Virginia	14-24" TL; 1 fish >24" allowed; 5 fish	14" TL; pound nets/seines allowed 5% by weight less than 14".  Hook & line fishermen must follow rec limits.  Quota: 51,104 lbs (Sept-Aug). After it's been announced the quota has been reached, then daily incidental catch of 50 lbs/licensee aboard the vessel, not to exceed 100 lbs per vessel
North Carolina	14" TL; 4 fish	14" TL; 75 fish limit. Unlawful to possess or sell Friday 12:00am-Sunday 12:00am.
South Carolina	14" TL; 10 fish. Gig March-Nov.	Gamefish status since 1987; native caught fish may not be sold.
Georgia	14" TL; 15 fish	14" TL; 15 fish. BRD requirement for trawl; gear mesh regulations.
Florida	15-19" TL slot; 1 fish >19" allowed per vessel, or per person if fishing on land; 0 captain and crew bag limit on for-hire trip; hook & line/cast net only. Western Panhandle: 3 fish, closed February; Big Bend: 5 fish; South: 3 fish; Central East: 2 fish, closed Nov -Dec; Northeast: 5 fish	Hook & line/cast net only; 15-24" TL; Season varies by region; 50 fish per person per day or 100 fish vessel limit with two or more licensed fishermen on board South, Big Bend, and Western Panhandle: Open June 1 - October 31. Central East: Open May 1 - September 30. Northeast: Open June 1 - November 30.

Note: A commercial fishing license is required to possess spotted seatrout for sale in all states with a fishery.

**Table 2.** Commercial landings (pounds) of spotted seatrout by state, 2014-2023 (Source: ACCSP for years prior to 2023 and State Compliance Reports for 2023). Totals are for the coastwide fishery and may extend beyond the management unit. "C" represents confidential data.

Year	NJ	DE	MD	VA	NC	SC	GA	FL	Total
2014			C	90,051	242,245	C	C	37,710	370,110
2015			C	7,888	128,752	C	C	39,226	175,931
2016			C	18,483	254,590	C	C	23,105	296,419
2017			C	55,219	299,910	C	C	16,194	371,590
2018			C	17,526	128,980	C	C	22,105	173,651
2019			C	100,763	378,491	C	C	16,700	531,010
2020		C	C	67,794	568,764	C	C	12,591	650,034
2021			C	51,594	694,784	C	C	12,352	760,690
2022	C		72	68,479	603,155	C	C	5,696	679,576
2023	133	0	1,596	70,913	434,610	0	0	10,732	522,290

**Table 3.** Recreational harvest (A + B1; numbers of fish) of spotted seatrout using the FES effort calibration, by state, 2014-2023 (Source: MRIP). Totals are for the coastwide fishery and may extend beyond the management unit.

Year	NJ	DE	MD	VA	NC	SC	GA	FL	Total
2014		3,514	21,560	84,537	725,086	260,321	724,411	1,111,177	2,930,606
2015		39	11,619	23,062	249,260	311,106	740,932	504,137	1,840,155
2016	547	12	10,092	163,529	978,624	311,168	1,290,220	962,946	3,717,042
2017			24,255	172,288	1,217,834	647,679	1,060,493	977,797	4,100,346
2018		344		189,537	449,473	175,191	1,096,602	929,155	2,993,485
2019		4,644	36,314	596,428	1,937,250	813,548	1,008,284	620,337	5,016,805
2020		774	11,951	591,624	2,053,354	511,261	830,771	678,934	4,678,669
2021			17,664	399,529	1,223,508	483,046	935,052	621,389	3,680,188
2022			8,739	248,150	1,963,400	281,274	952,260	337,142	3,790,965
2023			21,533	410,505	1,002,906	304,452	497,679	222,214	2,459,289



**Table 4.** Recreational harvest (A + B1; pounds of fish) of spotted seatrout using the FES effort calibration, by state, 2014-2023 (Source: MRIP). Totals are for the coastwide fishery and may extend beyond the management unit.

Year	NJ	DE	MD	VA	NC	SC	GA	FL	Total
2014		6,295	46,870	166,182	1,451,592	382,155	825,903	2,111,818	4,984,520
2015		10	23,546	48,477	430,579	462,498	794,861	984,940	2,744,901
2016	451	8	20,024	341,977	1,724,492	475,749	1,740,513	1,625,597	5,928,352
2017			48,624	342,463	2,157,198	992,938	1,403,646	2,011,777	6,956,646
2018		248		226,786	658,555	414,442	1,556,782	1,701,275	4,557,840
2019		10,878	61,935	1,256,916	3,334,163	1,238,834	1,440,368	1,033,847	8,366,063
2020		790	28,170	1,375,062	3,632,315	713,197	1,196,591	1,045,536	7,990,871
2021			40,801	815,724	2,241,421	696,038	1,277,168	956,682	6,027,834
2022			12,902	549,095	3,756,040	423,318	1,268,493	519,335	6,529,183
2023			47,091	938,451	1,923,165	463,895	669,434	313,986	4,356,022

**Table 5.** Recreational releases (number of fish) of spotted seatrout using the FES effort calibration, by state, 2014-2023 (Source: MRIP). Totals are for the coastwide fishery and may extend beyond the management unit.

Year	NJ	DE	MD	VA	NC	SC	GA	FL	Total
2014		2,926	74,250	1,059,287	3,949,284	1,407,310	1,687,540	7,279,660	15,460,257
2015		604	242,150	834,028	4,824,088	1,147,982	1,763,638	6,131,007	14,943,497
2016	15,423	15,066	133,223	3,708,969	6,475,193	1,791,072	2,113,253	4,783,644	19,035,843
2017	0	71	107,611	3,154,997	5,147,567	1,949,554	2,436,867	5,845,559	18,641,985
2018	418		54,795	4,455,420	15,245,249	1,062,769	2,022,125	5,306,034	28,230,566
2019	2,262	5,905	334,805	2,865,887	7,161,183	2,476,659	2,673,432	4,098,551	19,643,063
2020		9,027	237,023	2,830,854	6,155,571	1,301,634	2,632,036	5,306,269	18,471,640
2021			84,300	3,035,971	6,284,614	1,467,051	3,022,516	4,467,598	18,362,050
2022			97,241	2,291,186	10,860,575	1,189,063	2,039,833	5,667,898	22,145,796
2023		19,472	49,493	3,557,195	4,566,788	1,068,702	1,644,289	2,825,335	13,731,274

# Atlantic States Marine Fisheries Commission

## Coastal Pelagics Management Board

October 22, 2024

12:30 – 2:30 p.m.

### Draft Agenda

The times listed are approximate; the order in which these items will be taken is subject to change; other items may be added as necessary.

1. Welcome/Call to Order (*S. Woodward*) 12:30 p.m.
2. Board Consent 12:30 p.m.
  - Approval of Agenda
  - Approval of Proceedings from August 2024
3. Public Comment 12:35 p.m.
4. Update on SEDAR 95 Stock Assessment for Atlantic Cobia 12:45 p.m.
5. Consider 2025 Atlantic Cobia Regional Recreational Measures **Action** 12:50 p.m.
  - Technical Committee Report (*A. Giuliano*)
  - Consider Options for Northern Region Recreational Measures and Timeline for Selecting and Implementing Final Measures **Action**
6. Atlantic Cobia Technical Committee Report (*A. Giuliano*) 2:00 p.m.
  - Addendum II Confidence Interval Approach
7. Update from South Atlantic Fishery Management Council on Mackerel Port Meetings (*J. Carmichael*) 2:25 p.m.
8. Other Business/Adjourn 2:30 p.m.

The meeting will be held at The Westin Annapolis (100 Westgate Circle, Annapolis, MD; 888.627.8994) and via webinar; click [here](#) for details.

# MEETING OVERVIEW

**Coastal Pelagics Management Board**  
**October 22, 2024**  
**12:30 – 2:30 p.m.**

Chair: Spud Woodward (GA) Assumed Chairmanship: 1/24	Technical Committee Chair: Cobia: Angela Giuliano (MD) Spanish Mackerel: Vacant	Law Enforcement Committee Rep: Capt. Scott Pearce (FL)
Vice Chair: Lynn Fegley (MD)	Advisory Panel Chair: Craig Freeman (VA)	Previous Board Meeting: August 7, 2024
Voting Members: RI, NY, NJ, DE, MD, PRFC, VA, NC, SC, GA, FL, SAFMC, NMFS (13 votes)		

## 2. Board Consent

- Approval of Agenda
- Approval of Proceedings from August 2024

**3. Public Comment** – At the beginning of the meeting, public comment will be taken on items not on the agenda. Individuals that wish to speak at this time must sign-in at the beginning of the meeting. For agenda items that have already gone out for public hearing and/or have had a public comment period that has closed, the Board Chair may determine that additional public comment will not provide additional information. In this circumstance, the Chair will not allow additional public comment on an issue. For agenda items that the public has not had a chance to provide input, the Board Chair may allow limited opportunity for comment. The Board Chair has the discretion to limit the number of speakers and/or the length of each comment.

## 4. Update on SEDAR 95 Stock Assessment for Atlantic Cobia (12:45-12:50 p.m.)

### Background

- A benchmark stock assessment for Atlantic cobia, [SEDAR 95](#), is being conducted through the SouthEast Data, Assessment and Review (SEDAR) process.
- Assessment work began in March 2024 with an initial expected completion date of November 2025.
- The timeline has been delayed due to staff availability for a lead assessment analyst.

### Presentations

- Update on SEDAR 95 timeline from ASMFC Staff

## 5. 2025 Atlantic Cobia Regional Recreational Measures (12:50-2:00 p.m.) Action

### Background

- Atlantic Cobia Addendum II established a new regional recreational allocation framework, resulting in regional recreational harvest targets based on the current coastwide total recreational harvest quota of 76,908 fish per year from 2024-2026.

- To determine 2025 measures for each region, the average 2021-2023 recreational harvest for each region was compared against its regional harvest target.
- The Northern Region's (RI-VA) average harvest was above its target, requiring a 15.9% reduction in harvest in 2025.
- The Southern Region's (NC-GA) average harvest was below its target, so states in the Southern Region will maintain status quo measures for 2025.
- The Atlantic Cobia Technical Committee met in September 2024 to determine the methodology for calculating regional management measures and identify measures for the Northern Region to meet the required 15.9% reduction (**Briefing Materials**).

#### **Presentations**

- Technical Committee Report by A. Giuliano
- Overview of Potential Timelines for Selecting and Implementing Measures by E. Franke

#### **Board action for consideration at this meeting**

- Approve 2025 recreational measures for the Northern Region

### **6. Atlantic Cobia Technical Committee Report on the Confidence Interval Approach (2:00-2:25 p.m.)**

#### **Background**

- Atlantic Cobia Addendum II includes a provision allowing the Board to switch from the current rolling average approach using point estimates for harvest evaluations against targets, to a confidence interval approach for those evaluations to address the uncertainty around MRIP point estimates.
- In August 2024, the Board tasked the Cobia Technical Committee (TC) with reviewing and discussing the potential application of the confidence interval approach to the new regional allocation framework.
- The TC met in September 2024 to provide initial input on applying the confidence interval approach (**Briefing Materials**).

#### **Presentations**

- Technical Committee Report by A. Giuliano

### **7. Update on South Atlantic Fishery Management Council Mackerel Port Meetings (2:25-2:30 p.m.)**

#### **Background**

- The South Atlantic Fishery Management Council (SAFMC) is conducting a series of [port meetings](#) for king and Spanish mackerel throughout 2024 to gain a comprehensive understanding of those fisheries from stakeholders to inform management efforts.
- Port meetings have already taken place in North Carolina, New England states (virtual), New York, Georgia, South Carolina, and Florida.
- Port meetings in Virginia, Maryland, and New Jersey are being scheduled for November 18-21, 2024.

#### **Presentations**

- Update on SAFMC Mackerel Port Meetings by J. Carmichael

### **8. Other Business/Adjourn (2:30 p.m.)**

## Coastal Pelagics (Cobia and Spanish Mackerel)

**Activity level: Moderate**

**Committee Overlap Score: Moderate**

### Committee Task List

- Cobia TC – determine methods and conduct analysis for regional recreational measures for 2025 based on harvest target evaluation
- Cobia TC – Most TC members participate in the SEDAR 95 benchmark stock assessment process
- Spanish Mackerel TC/PRT – October 1: Compliance Reports Due
- Cobia TC/PRT – July 1: Compliance Reports Due

### Technical Committee Members:

**Cobia TC:** Angela Giuliano (MD, Chair), Nichole Ares (RI), Zachary Schuller (NY), Jamie Darrow (NJ), Brooke Lowman (VA), Melinda Lambert (NC), Justin Yost (SC), Chris Kalinowsky (GA), Christina Wiegand (SAFMC), Michael Larkin (SERO)

**Spanish Mackerel TC:** Reuben Macfarlan (RI), Zachary Schuller (NY), Jamie Darrow (NJ), Devon Scott (DE), Harry Rickabaugh (MD), Ingrid Braun (PRFC), Joshua McGilly (VA), McLean Seward (NC), Pearse Webster (SC), Jeff Renchen (FL), Christina Wiegand (SAFMC)

### Plan Review Team Members:

**Cobia PRT:** Angela Giuliano (MD), Chris McDonough (SC), Emilie Franke (ASMFC)

**Spanish Mackerel PRT:** McLean Seward (NC), Pearse Webster (SC), Christina Wiegand (SAFMC), John Hadley (SAFMC), Emilie Franke (ASMFC)

**DRAFT PROCEEDINGS OF THE  
ATLANTIC STATES MARINE FISHERIES COMMISSION  
COASTAL PELAGICS MANAGEMENT BOARD**

**The Westin Crystal City  
Arlington, Virginia  
Hybrid Meeting**

**August 7, 2024**

These minutes are draft and subject to approval by the [Coastal Sharks Management Board.  
The Board will review the minutes during its next meeting.

**TABLE OF CONTENTS**

Call to Order, Chair Spud Woodward .....1

Approval of Agenda .....1

Approval of Proceedings from May 1, 2024 .....1

Public Comment .....1

Consider Approval of Atlantic Cobia Fishery Management Plan Review and State Compliance for the 2023 Fishing Year .....4

Consider Atlantic Cobia Addendum II on Recreational Allocation, Harvest Target Evaluation, and Measures Settings for Final Approval .....4

    Review Options and Public Comment Summary .....4

    Advisory Panel Report .....5

    Consider Final Approval of Addendum II .....10

Update from South Atlantic Fishery Management Council on Mackerel Port Meetings .....29

Adjournment .....30

These minutes are draft and subject to approval by the Coastal Pelagics Management Board.  
The Board will review the minutes during its next meeting.

## INDEX OF MOTIONS

1. **Approval of agenda** by consent (Page 1).
2. **Approval of Proceedings of May 1, 2024** by consent (Page 1).
3. **Move to approve the Atlantic Cobia FMP Review for the 2023 fishing year, state compliance reports, and *de minimis* requests for Rhode Island, New York, New Jersey, Delaware, Maryland, Georgia, and Florida.** Motion by John Clark; seconded by David Sikorski (Page 3). Motion approved by consent (Page 3.)
4. **Motion to postpone deliberation on Addendum II to the Atlantic Cobia Management Plan until the Annual Meeting.** Motion by Erika Burgess; seconded by Doug Haymans (Page 10). Motion fails (4 in favor, 7 opposed, 1 abstention, 1 null). (Roll Call: In favor – SC, GA, FL, SAFMC; Opposed – RI, NY, NJ, NC, VA, PRFC, DE; Abstention – NOAA; Null – MD) (Page 16).
5. **Move to postpone final action on Addendum II until the Board receives the presentation of SEDAR 95 results and receives TC recommendations on applying SEDAR 95 to management, including recommendations for the total harvest quota.** Motion by Ben Dyar; second by Erika Burgess (Page 16). Motion fails (3 in favor, 7 opposed, 2 abstentions, 1 null). (Roll Call: In favor – SC, GA, FL; Opposed: RI, NY, NJ, NC, VA, PRFC, DE; Abstentions – NOAA, SAFMC; Null – MD) (Page 19).
6. **Main Motion**  
**Move to adopt for issue 3.1 Recreational Allocation Framework, a combination of Option C4 – Northern Regional Allocation for RI, CT, NY, NJ, DE, MD, VA and Option B2 – State Allocations for NC, SC, GA, with allocations based on 50% of 2014-2023 landings and 50% of 2018-2023 landings (excluding 2016, 2017, and 2020).** Motion by Shanna Madsen; second by Jason McNamee (Page 19).

### **Motion to Substitute**

**Motion to substitute to adopt Option A for Issue 3.1 until the SEDAR 95 stock assessment is concluded.**

Motion by Doug Haymans; second Ben Dyar (Page 20). Motion fails (3 in favor, 6 opposed, 2 abstentions, 2 null). (Roll Call: In favor – SC, GA, FL; Opposed – RI, NY, NJ, DE, PRFC, VA; Abstentions – NOAA, SAFMC; Null – MD, NC) (Page 22).

### **Main Motion**

**Move to adopt for issue 3.1 Recreational Allocation Framework, a combination of Option C4 – Northern Regional Allocation for RI, CT, NY, NJ, DE, MD, VA and Option B2 – State Allocations for NC, SC, GA, with allocations based on 50% of 2014-2023 landings and 50% of 2018-2023 landings (excluding 2016, 2017, and 2020).** Motion by Shanna Madsen; second by Jason McNamee. Motion substituted (Page 22).

### **Motion to Substitute**

**Move to substitute to approve in Section 3.1 Recreational Allocation Framework Option C4. regional harvest allocations based on 50% of 2014-2023 landings and 50% of 2018-2023 landings (excluding 2016, 2017, and 2020) with a northern region of Rhode Island through Virginia and a southern region of North Carolina through Georgia.** Motion by Ben Dyar; second by Doug Haymans (Page 23). Motion passes (11 in favor, 2 abstentions). (Roll Call: In favor – RI, NY, NJ, FL, NC, VA, PRFC, MD, DE, SC, GA; Abstentions – NOAA, SAFMC) (Page 23).

### **Main Motion as Substituted**

These minutes are draft and subject to approval by the Coastal Pelagics Management Board.

The Board will review the minutes during its next meeting.



**Move to approve in Section 3.1 Recreational Allocation Framework Option C4. regional harvest allocations based on 50% of 2014-2023 landings and 50% of 2018-2023 landings (excluding 2016, 2017, and 2020) with a northern region of Rhode Island through Virginia and a southern region of North Carolina through Georgia. Motion carries without opposition (Page 24).**

7. **Move to adopt for issues 3.2 Updates to State/Regional Allocations - Option B Allocation Changes via Board Action, 3.3 Data and Uncertainty in Recreational Landings Evaluations - Option B Extend Rolling Average to Five Years, 3.4 Overage Response for Recreational Landings Evaluations – Option A Status Quo, 3.5 Timeline for Setting Commercial and Recreational Measures – Option B Five-Year Specifications.** Motion by Shanna Madsen; second by John Maniscalco (Page 24). Motion passes (10 in favor, 3 abstentions). (Roll Call: In favor – RI, NY, NJ, NC, VA, PRFC, MD, DE, SC, GA; Abstentions: FL, NOAA, SAFMC) (Page 27).
8. **Move to approve Addendum II to Amendment 1 to the Atlantic Cobia FMP, as modified today, with an implementation date of today (August 7, 2024).** Motion by Shanna Madsen; second by John Clark (Page 29). Motion passes by unanimous consent (Page 29).
9. **Move to adjourn** by consent (Page 30).

**ATTENDANCE**

**Board Members**

Jason McNamee, RI (AA)	Chris Batsavage, NC, proxy for K. Rawls (AA)
Eric Reid, RI, proxy for Sen. Sosnowski (LA)	Chad Thomas, NC, proxy for Rep. Wray (LA)
John Maniscalco, NY, proxy for M. Gary (AA)	Ben Dyar, SC, proxy for Blaik Keppler (AA)
Jim Gilmore, NY, proxy for Sen. Thiele (LA)	Mel Bell, SC, proxy for Sen. Cromer (LA)
Joe Cimino, NJ (AA)	Malcolm Rhodes, SC (GA)
Jeff Kaelin, NJ (GA)	Doug Haymans, GA (AA)
Adam Nowalsky, NJ, proxy for Sen. Gopal (LA)	Spud Woodward, GA (GA)
John Clark, DE (AA)	Erika Burgess, FL, proxy for J. McCawley (AA)
Craig Pugh, DE, proxy for Rep. Carson (LA)	Gary Jennings, FL (GA)
Roy Miller, DE (GA)	Ron Owens (PRFC)
Lynn Fegley, MD (AA)	John Carmichael (SAFMC)
David Sikorski, MD, proxy for Del. Stein (LA)	Jack McGovern (NMFS)
Shanna Madsen, VA, proxy for Jamie Green (AA)	

**(AA = Administrative Appointee; GA = Governor Appointee; LA = Legislative Appointee)**

**Ex-Officio Members**

Angela Giuliano, MD, Cobia TC Chair

**Staff**

Bob Beal	Caitlin Starks	Katie Drew
Toni Kerns	Jeff Kipp	Jainita Patel
Tina Berger	Tracy Bauer	Chelsea Tuohy
Madeline Musante	James Boyle	Emilie Franke

The Coastal Pelagics Management Board of the Atlantic States Marine Fisheries Commission convened in the Jefferson Ballroom of the Westin Crystal City Hotel, Arlington, Virginia, via hybrid meeting, in-person, and webinar; Wednesday, August 7, 2024, and was called to order at 1:15 p.m. by Chair Robert E. Beal.

### CALL TO ORDER

CHAIR ROBERT E. BEAL: I'm going to call the Coastal Pelagics Board to order. Again, my name is Bob Beal. This is like déjà vu all over again from this morning. Spud Woodward is online but realizes that chairing this meeting remotely or virtually is difficult to do. He asked me to stand in and be the Chair for this meeting, and I'm glad to do that.

### APPROVAL OF AGENDA

CHAIR BEAL: Spud will likely be participating virtually in the conversation, however. With that we'll go ahead and review the agenda. Are there any changes or edits to the agenda that was provided ahead of time? Not seeing any; the agenda stands approved.

### APPROVAL OF PROCEEDINGS

CHAIR BEAL: Then consideration of approval for the Proceedings from May 2024. Are there any edits or changes to the proceedings from May, '24? Yes, Emilie.

MS. EMILIE FRANKE: Just to let the Board know, we did receive two edits on Page 11 and Page 17, just making sure the names of Board members who provided comments are correct.

### PUBLIC COMMENT

CHAIR BEAL: Great, thank you, and we will make those changes. All right, with that it brings us to Public Comment. Are there any members of the public that would like to comment to the Board at this time? Seeing no hands in the room and no hands online, we will jump right into the FMP Review for Cobia. Emilie, take it away, thank you.

These minutes are draft and subject to approval by the Coastal Pelagics Management Board. The Board will review the minutes during its next meeting.

### CONSIDER APPROVAL OF ATLANTIC COBIA FISHERY MANAGEMENT PLAN REVIEW AND STATE COMPLIANCE FOR THE 2023 FISHING YEAR

MS. FRANKE: For this Cobia FMP Review, this is for fishing year 2023, so I will go over the status of the FMP, status of the stock, the fishery and the PRT comments, and the Board's action for consideration today is to consider approving this review for fishing year 2023, the state compliance reports and *de minimis* requests. For the FMP, cobia is currently managed under Amendment 1 and Addendum I to Amendment 1. Again, this is the Atlantic cobia stocks, so we're only talking about cobia from the Florida/Georgia border and northward.

Amendment 1 transitioned Atlantic cobia to sole management by the Commission, and currently the total harvest quota, this is across both sectors, is 80,112 fish. This was initially set as a total quota in 2020 and has been the total harvest quota since then. It is currently set for 2024 through 2026. The allocation is 96 percent recreational and 4 percent commercial, and in 2023, there were no management changes. States maintained the same management measures they had in place in 2021 and 2022. For the commercial fishery, the coastwide quota is about 73,000 pounds. It's a 33-inch fork-length minimum size limit, 2 fish per person, 6 fish per vessel, and non *de minimis* states do submit landings reports in season. If we reach the commercial closure trigger, then the commercial fishery closes with 30-day notice, and 4 percent of the commercial quota is set aside to cover *de minimis* harvest.

For the recreational fishery there is a 76,908 fish coastwide harvest quota. The non *de minimis* states right now are Georgia, South Carolina, North Carolina, and Virginia. They have a minimum size of 40-inch total length or 36 inches fork length, and the seasons and the vessel limits for those states are determined by each state, but the maximum vessel limit is 6 fish.

Each of these four states has a state-specific harvest target, and every few years there is an evaluation of the state's average landings against that target, to

determine if they have to make changes to those seasons or vessel limits. Then right now, the *de minimis* states are from Maryland northward.

They have a different set of measures, a minimum size of 37 inches total length, and 33 inches fork length, a vessel limit of 1 fish, and a year-round season, or *de minimis* states can choose to implement the same measures as the nearest non *de minimis* state. For example, Maryland and PRFC have implemented the same measures as Virginia.

For these *de minimis* states, there is a quota set aside to cover the *de minimis* harvest. There is no *de minimis* evaluation against any sort of target. As far as the status of the stock, SEDAR 58, which was completed in 2020 with data through 2017, indicated the stock was not overfished, and overfishing is not occurring.

There is a new stock assessment, SEDAR 95 that is ongoing as we speak, and is expected to be complete in late 2025. As far as the fishery, last year in 2023 total landings across both sectors was about 2.8 million pounds. Commercial comprised about 2 percent of that and recreational almost 98 percent of those landings.

In 2023 landings were a 45 percent increase from 2022, driven by an increase in recreational landings. On the commercial side, landings were about 64,500 pounds. This was a decrease from 2022 and was below the commercial quota. North Carolina and Virginia comprised the majority of landings, and again, the quota was not exceeded, and so the commercial fishery was not closed.

On the recreational side, recreational landings last year were 98,311 fish. This is the second highest harvest in the time series and a 41 percent increase from 2022. Just note that the 2023 landings were above the coastwide quota. Just to sort of illustrate the increase in landings we've seen in the past decade or so.

Over the past ten years the average landings were about 79,500 fish versus the time series average of about 40,500 fish. Then as far as live releases, live releases last year about almost 249,000 fish were released alive. The PRT just notes that in the most recent years we've seen an increase in the proportion of fish that have been released alive, as compared to previous years. This is just a figure of total landings in pounds. You can see in orange there at the bottom the commercial sector relatively stable, given their percent quota that they are allocated. Then you can see the recreational landings in blue. You know you see the increase in recent years, but you also see the continued year to year variability that we tend to see with cobia.

Here on the screen, I know it is a lot to look at, but just to kind of give a little bit of visual of the recreational landings data in number of fish for the last ten years. Then at the bottom you can see the current state targets. You can see the *de minimis* states from Rhode Island through Maryland, pretty variable.

Some years you see a couple thousand fish harvested, however, last year in 2023 it was a much lower harvest estimate. You can see Virginia has been above their target in recent years. North Carolina has seen a little bit of a decrease and has been below their target. South Carolina has been just below or sort of right around their target in recent years, and then Georgia has had a couple years below their target, and then a couple years above their target.

Again, some variability. You can see in red there '21 and '23, the coastwide recreational quota was exceeded. The PRT does want to note that changes in harvest year to year for states is likely due to multiple factors, including poor stock distribution. But also, fish availability nearshore or offshore, as well as state regulatory changes in effort.

Then the other item of note for last year was North Carolina's harvest estimate was very low. North Carolina noted that weather conditions in 2023 reduced the number of fishable days, and anecdotal observations in North Carolina suggest that cobia

These minutes are draft and subject to approval by the Coastal Pelagics Management Board.  
The Board will review the minutes during its next meeting.

are staying in North Carolina waters for a shorter period of time. This all could have contributed to that low estimate.

The PRT does want to note though that this could be an anomaly, and future estimates may not be this low. As far as implementation, the PRT found no inconsistencies in state implementation. Just of note that New York did declare an interest in the cobia FMP earlier this year. New York has implemented measures consistent with a recreational *de minimis* state, and also implemented commercial measures for a non *de minimis* state.

New York is providing in-season landings reporting at this time. As far as *de minimis*, *de minimis* qualifies for the recreational sector if states have been less than 1 percent of the coastwide total for two or three years. Rhode Island, New York, New Jersey, Delaware, Maryland, and Florida have requested and qualified.

On the commercial side states need to be less than 2 percent of coastwide landings for two or three years. Rhode Island, New Jersey, Delaware, Maryland, Georgia, and Florida have all requested and all qualify except for New Jersey. New Jersey landings did exceed that 2 percent threshold in 2021 and 2023.

However, New Jersey is still requesting *de minimis*. They note that those landings were anomalously high, compared to their past decade, and New Jersey notes they are continuing to work toward in-season reporting should that become necessary. As far as PRT comments, the PRT recommends the Board approve all *de minimis* requests, including the New Jersey commercial request. The PRT notes that multiple states could exceed the *de minimis* threshold over the next few years if landings continue to increase in the Mid-Atlantic. This could have some implications, including more states needing to implement in-season monitoring. If state allocations are

maintained, then that would mean adding new states to the allocation framework.

This all kind of reflects some of the challenges and why Draft Addendum II was initiated. Then again, just a reminder that we have this new stock assessment that will inform stock status in management in the near term. I'm happy to take any questions.

CHAIR BEAL: Great, thanks, Emilie, appreciate that. Are there questions or comments on the FMP review? Yes, Joe.

MR. JOE CIMINO: Not a question, I just want to make a comment on New Jersey's commercial harvest. It's not a directed fishery, it's bycatch in our gillnet fishery, and it's really a small number of individuals, which does give us, we feel that if we need to move into a more update reporting system, that we can do that, getting into compliance then if it comes to that.

CHAIR BEAL: Great, thanks, Joe. Any other comments or questions? I keep forgetting to look online. Not seeing any. Great, is there a motion to approve the FMP Review and *de minimis* requests? John, I think we will have a motion on the board you can read in, hopefully.

MR. JOHN CLARK: **Move to approve the Atlantic Cobia FMP Review for the 2023 fishing year, state compliance reports, and *de minimis* requests for Rhode Island, New York, New Jersey, Delaware, Maryland, Georgia, and Florida.**

CHAIR BEAL: Great, thank you, is there a second to that? Dave Sikorski, thank you. **Any objection to the motion on the board to approve the FMP Review and *de minimis* requests? Seeing none; it stands approved.** Thank you, Emilie, and the Board. Now we move on to Addendum II.

These minutes are draft and subject to approval by the Coastal Pelagics Management Board.  
The Board will review the minutes during its next meeting.

**CONSIDER ATLANTIC COBIA ADDENDUM II ON RECREATIONAL ALLOCATION, HARVEST TARGET EVALUATION, AND MEASURES SETTINGS FOR FINAL APPROVAL**

CHAIR BEAL: We're going to go through essentially the usual process, which is reviewing the options that are in the document, and public comment summary and the Advisory Panel report, and then the Board will consider action on the final approval of Addendum II. With that, Emilie, are you ready to go? Jump right into the options and public comment summary, thank you.

**REVIEW OPTIONS AND PUBLIC COMMENT SUMMARY**

MS. FRANKE: I'll just plan at the beginning just one or two slides. I'm reminding everyone the current recreational management framework, because I think that is helpful as a reminder, before we get into the options. Then I will get into the options, the public comment summary and the AP report, sort of all in one.

The AP Chair could not be here today, so asked that I give the report. It is a lot of information to go through after each set of options I will talk through the public comments and AP comments for that set of options before I move on to the next set. Just bear with me. Just a visual reminder of how the current recreational management framework works. At the top you have the harvest quota that can be set for up to three years at a time. In that green box 1 percent of that recreational harvest quota is set aside for *de minimis* states, then you have the rest of the quota that is currently allocated to Georgia, South Carolina, North Carolina, and Virginia, currently based on landings data from 2006 to 2015. Then those allocation percentages determine the state harvest targets in number of fish. Then those four states again, every few years evaluate their average harvest relative to those targets. If they exceed the targets the state has to adjust measures to reduce to the target. If their harvest has been

below their target, they have the option to liberalize measures. That is where we are in terms of status quo.

Just a reminder, as I mentioned earlier, the total harvest quota and state recreational measures have been status quo for the last few years. The Board also decided to maintain status quo state recreational measures for this year for 2024, instead of adjusting measures based on the harvest evaluations.

Recreational measures could change for 2025. This Addendum would determine the allocation framework, which would determine the state harvest targets for 2025, which would impact the evaluations to determine the 2025 measures. Also, a reminder that measures could potentially change again in 2026 or 2027, as we get the results of the next stock assessment. That is SEDAR 95. It's expected to be complete in late 2025, so it is not clear whether we would have that information in time to inform 2026 management or not.

That leads us to Draft Addendum II, which covers several topics. This Addendum was initiated due to the concern about the data currently used for state allocations, which is currently 2006 to 2015. The distribution of landings has changed since 2015. We've seen increased landings in some Mid-Atlantic states, but has been relatively stable in southern states, which indicates a possible range expansion.

We've also had a couple states declare into the fishery, because of increasing cobia presence in their state waters. Updating the allocation data could account for these changes. Also, MRIP estimates for cobia tend to have really high PSEs. There have been some concerns about using these uncertain data to make state level management decisions.

One way to potentially reduce this uncertainty is by increasing the sample size and considering management at a regional or coastwide level. This Addendum also considers other ways to address uncertainty, so thinking about the number of years included in the average we're using for landings

These minutes are draft and subject to approval by the Coastal Pelagics Management Board.  
The Board will review the minutes during its next meeting.

evaluations, whether to use point estimates, and also thinking about whether to compare a state's performance on its own or relative to other states or regions.

Then also, there is this potential need to update allocation percentages in the future. If updates are considered via addendum, for example like this process. This of course takes several months. The Board is considering whether or not to be able to make changes in certain situations via Board action.

Then finally, there is concern about changing management measures too frequently. Right now, the Board can set the quota for up to three years, and the Board is considering whether or not to consider setting measures for a longer period of time. Here is the timeline. The Board initiated this Addendum back in October. The Addendum was developed and then approved for public comment in May. We did have our public comment period in June and early July, and we're currently here in August to review public comment, select management measures, and consider final approval of the Addendum. As far as the public comment period, we received 7 written comments from 6 individuals and 1 organization. We did hold 7 public hearings, 4 of those were in person and 3 of them were via webinar. There were 37 members of the public who attended, and some attendees provided comments. Some of those comments were on the specific options, others were on for the more general cobia management topics.

#### **ADVISORY PANEL REPORT**

Then the Advisory Panel, which is the South Atlantic Species Advisory Panel, as a reminder that is still a combined advisory panel covering both sciaenids and cobia and Spanish mackerel. The AP met on July 25, and we had five AP members in attendance from Virginia and North Carolina.

Getting into the management options. As I mentioned, I will go through each of these five option sets, and within each of those option sets I will go over the public comment and the AP report for those relevant options. First, Section 3.1. This is one of the biggest sections in this Addendum. This is the recreational allocation framework, and there is sort of two components to think about here.

The first is how the recreational quota is allocated at a geographic level, so state by state, regional or coastwide. The second thing to think about is the timeframe of data being used. Currently, we use a combination of 2006 to 2015 data, and 2011 to 2015 data. Alternatively, this Addendum considers using 2018 to 2023 data. However, excluding 2020 due to COVID impacts.

Then the other option is using a combination of 2014 to 2023 data, and 2018 to 2023 data. Just going back just a little bit further in the dataset. Again, you would exclude 2020, we would also exclude 2016 and 2017, because there were fishery closures during those years. As far as the options, we first start with the state-by-state framework.

Option A would be status quo. We have those state-specific targets, state-specific allocations, and the state specific targets for state specific management measures. Option B would maintain that same state by state specific framework, but it would update the data used for those allocations, so it would consider using those more recent data.

The Option B options would also consider increasing the amount of the quota that is set aside for the *de minimis* states. Currently, 1 percent of the quota is set aside to cover harvest in the *de minimis* states. These option B alternatives would set aside 5 percent to cover harvest in *de minimis* states.

On the screen you can see the allocation percentages for each of the options. I'm not going to go through each one, but you can see status quo, Option A, using the 2006 through 2015 data. Then you can see for Options B1 and B2, a lot of that quota shifts up to Virginia. You see Virginia's quota increases.

These minutes are draft and subject to approval by the Coastal Pelagics Management Board.  
The Board will review the minutes during its next meeting.

You see that set aside for *de minimis* states also increase, then you see a pulse of decrease in the North Carolina, South Carolina, and Georgia quotas. I did have a request from a Board member to include in my presentation what these percentages would mean for state targets in 2025, so just applying these percentages to our current total recreational quota. I'll show those up on the screen, but I just want to emphasize, this is under our current 76,908 quota regime. Of course, as this total quota changes, these state targets will change. But I had a request to include these calculations in the presentation. I also included here on the right in that gray column the average harvest for each date for the last three years.

These are the data that would be used in the harvest evaluations. I'll leave it up here for just a beat or two. As I mentioned, you can see Virginia's average harvest has been over the targets. North Carolina has been below their targets, and then depending on the option that you select, South Carolina has been either over or under, and then Georgia has been over as well.

As an alternative to a state-by-state framework, Option C considers a regional allocation framework. For all of these regional options they would use the more recent data. The goal here is to eventually establish a region-wide size and vessel limit for all the states that are in a region. States could still have different seasons, because cobia availability really depends on which state you're in, time of year.

But all states in a region would eventually have to have the same size and vessel limit. The next time a reduction is needed, which could be for next year, or after the next stock assessment. The states in a region would work together to determine what the regional measures would be. Up on the screen here you have the regional options.

The top half of the options would be a regional breakdown at the North Carolina/South

Carolina border. Your northern region would be North Carolina north, and your southern region would be South Carolina and Georgia. You can see that of course the northern region would have the majority of the quota, and then the South Carolina and Georgia would have about 12 to 13 percent. Again, these options are all using the more recent data.

The other bottom half of these options would be a different regional split at the Virginia/North Carolina line, so the northern region would be Virginia north. The southern region would be North Carolina, South Carolina, and Georgia. Again, with that request to see what those allocation percentages would translate to, in terms of state targets under our current 76,908 fish quota regime that is here on the screen.

You can also see the average harvest for each of the regions. For the first regional breakdown, both the northern and southern region have been above the potential targets. For the second regional breakdown, the northern region has been above their target, and the southern region it depends which option you choose. I'll leave it up there for just a beat.

Finally, as an alternative to state or regional allocations, we simply have a coastwide management. We would only have that coastwide recreational quota. There would not be any state or regional allocations. The goal here is that eventually all states in the management unit would have the same size and vessel limit, working toward that coastwide target. Again, states could have different seasons. The next time a reduction is needed or after the next stock assessment, the states would work to determine what the coastwide measures would be to reach the target. Again, just sort of where are we right now. The current coastwide quota is 76,908 fish. The coastwide average for the last three years has been about 86,000 fish. In terms of public comments. On the recreational allocation framework, we heard one comment for Option A, status quo, noting that high uncertainty, low harvest in the northern states, and the fact that overfishing is not occurring means that

These minutes are draft and subject to approval by the Coastal Pelagics Management Board.  
The Board will review the minutes during its next meeting.



management should not change., things should just remain status quo.

We did hear two comments for the state-by-state allocations using the more recent data, indicating that it is important to use the new data, and this would be easier to coordinate keeping that state-by-state allocation. We did hear some concerns from South Carolina stakeholders that South Carolina with their proposed decreased allocation would essentially be penalized for the conservation action that the state has voluntarily taken in implementing a spawning closure.

I believe that was in 2018, so that closure decreased harvest, and therefore decreased as opposed to allocation. We also heard one comment for the regional allocation, noting that this would best address uncertainty, and one comment for coastwide management, noting that this is the best way to address the MRIP PSE issue, and also captures the coastwide changes in stock distribution.

There were some commenters that did not select an option, but they noted that they are opposed to increasing Virginia's allocation. They noted there would be negative impacts to the stock if more quota were given to Virginia, due to higher effort, that this would not protect the resource questions about why management should change in the southern states when the impact is coming from the Mid-Atlantic states, and equity concerns about reducing quota in states that have important historical cobia fisheries.

Then one commenter also noted that the combined 10 year and 6-year timeframe would incorporate the most years of data. As far as the Advisory Panel, we did have 4 AP members who supported status quo. The AP members noted there should be no change while we have a current stock assessment in the works, that again, overfishing is not occurring so there is no reason to change anything before the next assessment.

These minutes are draft and subject to approval by the Coastal Pelagics Management Board.  
The Board will review the minutes during its next meeting.

They noted that changing management now and again after the assessment would be difficult on stakeholders, and concern that the proposed 2018 to 2023 basis for new allocations is too short of a timeframe, given the high uncertainty and the pulse nature of the fishery. Then we had 1 AP member that supported state allocations, somewhere between status quo and Option B.

This AP member noted that Virginia's allocation could increase, but not by the full amount proposed in the Addendum, and concern that if management moved to coastwide, without having some sort of state or regional allocation that Virginia's harvest could increase even more. That was the first section. That is by far the longest section.

I am going to go through the rest of the options and public comments, and then I am happy to take any questions. The next section is 3.2. This is future updates to allocations. Option A is status quo, allocations can only be changed via the addendum or amendment process. Then Option B would be a change via Board action. Allocations could change via Board action, but only under two very specific scenarios. One would be if a state loses *de minimis* status and needs their own harvest target, that is if we keep the state-by-state allocations, or if the harvest estimates for our source data are changed. For example, if we have those potential updates to MRIP data in the future, the Board could potentially address that via Board action.

As far as public comments on this section, we had two comments for the status quo Board Addendum process, noting that future discussions of allocations should have sort of more attention and high level of discussion and public participation. Also, a similar comment to before that given high uncertainty and overfishing not occurring, management process should simply stay the same right now.

The AP did not have any specific comments on this particular section. Moving on to Section 3.3 now. This is the data and uncertainty in the harvest target evaluations. Option A is status quo, and we use up to a three-year rolling average of harvest

data in the evaluations against the target. Just as a reminder, this is three years under the same management measures. Option B, the alternative here would be to use up to a five-year rolling average. Again, this would have to be five years under the same management measures.

For this next evaluation, since the last management change that we had was 2021, we could still only use three years. But this option would give the Board in the future the potential to use up to five years. Just sort of a reminder in this section. There is a provision we're calling the confidence interval provision.

If the Board were to move to a regional or coastwide framework, the Board could potentially in the future switch to using confidence intervals instead of averages of point estimates. This would be to directly address uncertainty. Again, you know we have the point estimates on the left as we compare the average against the target.

If the Board switched that confidence interval approach in the future, we could evaluate for each year, if the target fell within that confidence interval. That is not something the Board necessarily has to decide today. This is something the Board could address if they wanted to switch in the future.

As far as the public comments, we had two comments for the status quo, Option A, the three-year average, concern that we don't want too much time between evaluations, we don't want to miss a trend and take action too late, and again, management should stay the same given where things are right now. We also had two comments for the alternative, the five-year average, noting that additional years of data would help level out the landings, especially in low harvest years that might have been due to poor fishing conditions.

We had two AP members who supported that five-year average, again more data are better,

could balance out those years that are affected by weather conditions, limiting effort. Then we also had one AP member note support for that confidence interval approach in the future. Section 3.4, this is on the overage response during these evaluations. Status quo here if a state or a region exceed their target, that state or region has to adjust their measures to reduce down to their target. The alternative here is what we're calling performance comparison. If a state or region exceeds their target a reduction would not be required if two criteria are met. One, if another state or region is below their target, and that state or region is not liberalizing their measures, and two, if we have not exceeded the coastwide quota. We had two public comments for status quo, noting that we should keep the accountability by state, and also again that management should stay the same, given where things are in terms of uncertainty, overfishing not occurring.

For the AP comments we had one AP member who noted he would typically support Option B, so taking into account you know the performance of all states or regions, and performance of the coastwide quota. But he was unsure whether or not to support this for cobia, just due to the high uncertainty in determining how close are we actually to the target.

On to the last section here, this is the timeline for setting measures. The status quo here is the Board can set specifications for up to three years. The alternative is the Board could set specifications for up to five years. Again, the intent here is to reduce the frequency of management changes, and to better align with when the stock assessment would be available.

For public comment, we had two comments for status quo, setting measures for up to three years. Again, concern that five years would be too long. The assessment wouldn't provide that much new information, since cobia are pretty data limited, and again that same comment that everything should stay status quo, given the high uncertainty, low harvest in the northern states, and overfishing not occurring.

These minutes are draft and subject to approval by the Coastal Pelagics Management Board.  
The Board will review the minutes during its next meeting.

We then had four comments for Option B, setting measures for up to five years, noting that there is a need for consistency and continuity in the regulations, and to align with the stock assessments. As far as the AP comments, we had 1 AP member support setting measures for up to 5 years, again noting the importance of aligning with stock assessments. With that I am happy to take any questions. I know I went through that a little bit expediently. I am happy to go back to any slides.

CHAIR BEAL: Thanks, Emilie, as always, a great presentation. Any questions for Emilie? Lynn, go ahead, please.

MS. LYNN FEGLEY: Thank you, Emilie, for the excellent job running through that. Can you help me understand. I'm a little confused about the confidence interval approach and the reference to in the future. What does future mean in the mind of a PDT? Is that with the recalibration, or what is that?

MS. FRANKE: The PDT left that pretty open, sort of basically it's up to the Board, and the Board has the ability to make that switch to the confidence interval approach via a vote, so it wouldn't have to be an addendum. I think the PDT was thinking maybe when we have the new MRIP estimates.

Maybe if the Board switches to a regional approach, and uses that approach for a few years, and decides that it makes sense with the data to use a confidence interval approach. It is a little bit open, and I think depending on which allocation framework the Board selects for this Addendum, the Board could ask the TC to take a closer look at what are the PSEs, at whatever geographic scale we have. Would the confidence interval approach be viable at this time? It's a little slow open.

CHAIR BEAL: John Clark, please.

MR. CLARK: Thanks for the great presentation, Emilie. My question is actually more toward the states that have bigger cobia fisheries. I mean we've had these discussions. There has been a lot of concern about reallocation, and yet when I look at the public hearings and the comments, it doesn't look like there was that much public interest. I'm just curious for those states that do have the bigger cobia fisheries, if they had any thoughts as to why this document, which may actually result in some fairly large changes in allocation, has not elicited more public interest.

CHAIR BEAL: I'll look for hands from those states, yes 37 members of the public going to hearings is not a big crowd is it. We'll go to Shanna and then Chris.

MS. SHANNA MADSEN: Yes, thanks for the question, John. I found myself asking that question as well. I did talk to our AP members, and there seem to be some confusion surrounding the document, as to when things would be implemented. A lot of people said they were having a hard time essentially engaging with some of their constituents.

Because people didn't understand that essentially no matter what in 2025, some levels of changes are going to have to be made to most of our state's management measures. I think there was a lot of hesitancy there in kind of speaking up and saying what was preferred, because they thought if they kind of ignored it, then there would not be management measure changes in 2025, frankly.

CHAIR BEAL: Chris, do you have some perspectives as well?

MR. CHRIS BATSAVAGE: Yes, the short answer is I'm not sure why we had such low turnout in North Carolina, but online and in person I went to considerable lengths to get the word out and to set the meeting up, the in-person meeting, to be as convenient as possible for people who fish for cobia, and they still didn't show up. I mean I have just got to look at, at least in North Carolina, the lack of public engagement.

These minutes are draft and subject to approval by the Coastal Pelagics Management Board.  
The Board will review the minutes during its next meeting.

Outside of the AP, I will credit the AP was well attended by North Carolina members, that although cobia is an important recreational fishery, it is pretty far down the list, in terms of important fisheries, at least in North Carolina, and I'm just meaning look at the landings and the timing of the fishery. But I think also, just the lack of engagement in an important action like this. I think that probably spoke louder to me than no one turning out. That is just kind of my perspective on it. Thanks.

CHAIR BEAL: John, you have follow-up?

MR. CLARK: I was just curious if either Georgia or South Carolina had any input. You know as I said, I know that it seems from the conversations we've had here, they were both very concerned in their states about the reallocation.

CHAIR BEAL: Yes, Doug Hayman and Ben Dyar have their hands up online, so I will go to Doug first, please.

MR. DOUG HAYMANS: I don't mean to be flippant about this comment, but red snapper. I think there is a high level of apathy amongst our fishing public. They don't believe that we're hearing them, and it's possibly due to red snapper issues and other things that are outside of the Commission's purview. But we had 7 members of the public plus a whole lot of staff there. I mean overall, that is probably average for what we get in Georgia, no matter what the fishery is. But I do think that other issues affected this and other meetings.

CHAIR BEAL: Ben, you are ready to go.

MR. BEN DYAR: The in-person meetings, I think we had 12 or 13, which we were relatively happy with, obviously more is always better, and had some good comments in that in-person meeting. The virtual meeting from our end was poorly attended, but we do have a historical very important fishery down in the southern zone, South Carolina.

Some of those comments alluded to that. It is still felt in those areas. But as far as more people, I'm not sure if it was the timing of everything, where we were kind of first on the list. You know it was kind of, about a week maybe week and a half turnaround to get the word out. We did as much public outreach as we could, with all the different groups. But again, felt like our attendance in the in-person meeting was relatively well attended.

CHAIR BEAL: Great, thanks, Ben. Other comments or questions around the table on Emilie's presentation?

### APPROVAL OF ADDENDUM II

CHAIR BEAL: Not seeing any around the table or online, so that brings us to considering approval of Addendum II. I see Erika's hand up, go ahead, please.

MS. ERIKA BURGESS: Thank you, Bob. Given the fact that many of the Commissioners that would be affected by their state specific by the decisions made today, I would like to **offer this motion for the Board. That would be to postpone deliberation on Addendum II the Atlantic Cobia Management Plan until the annual meeting.**

CHAIR BEAL: Thank you, Erika, is there a second to that motion? I see Doug Hayman's hand up online, so I am going to assume that is a second from Doug, unless I hear different. Erika, do you want to comment more on the motion?

MS. BURGESS: Yes, Bob, thank you. Having experienced the challenges with participating in a hybrid meeting on Monday with the discussions about menhaden, I know how difficult it is, sorry that was Tuesday. I know how difficult it is to engage and have dialogue and discussions, and effectively make your case for your positions. I think just out of consideration for the folks who are unable to be here out of something that is completely out of their control, I would like to give them the opportunity to discuss this in-person in the fall.

These minutes are draft and subject to approval by the Coastal Pelagics Management Board.  
The Board will review the minutes during its next meeting.

CHAIR BEAL: Doug, as seconder of the motion, do you have any comments on it?

MR. HAYMANS: Considering the difficulty I have in unmuting myself, I think Erika has made the point quite well, and I agree with her motion and her reasoning.

CHAIR BEAL: I have Ben Dyar's hand up online, go ahead, Ben.

MR. DYAR: I was actually going to second the motion as well, but now that I'm online. Yes, difficulties in trying to communicate. You know I know we have hybrid opportunities, but not sure if they were exactly foreseeing this specific scenario, where something, a large decision that could affect a lot of constituents in our state and others, trying to have these dialogues in person, and then being virtual making it very difficult to have that back and forth. Anyway, just wanted to second that as well.

CHAIR BEAL: Other comments around the table? John Clark.

MR. CLARK: Just curious what this would do to the timeline if this was postponed until the annual meeting.

CHAIR BEAL: Emilie, can you handle that?

MS. FRANKE: Yes. If the Board was interested in applying any potential new allocation framework for 2025, this would obviously shorten the timeline for getting 2025 measures in place. If the Board selected options at the annual meeting, so it would be up to the Board and states as to how fast they could then do their evaluations against the target, and figure out what the new management measures would be for 2025, and also discuss, would measures be ready in time for January?

I would guess probably not. Would it be something like a middle of 2025 implementation or would states just need to wait until 2026 to sort of use that new

allocation framework? That does still leave the question of what to do for 2025, and I think the Board is sort of still in the position of using the current allocations then perhaps to figure out 2025 measures, or as I mentioned, using any new allocation and maybe implementing like mid-2025.

CHAIR BEAL: All set, John? Other questions or comments on the motion? Dave.

MR. DAVID SIKORSKI: I'm supportive of the motion, but I am interested in hearing other states talk about what is the big problem with this extension. One question that comes to mind with Emilie's last comment is, what is the earliest season that any state has on the coast, and how does October affect implementation for that? I'm comfortable with not changing anything for 2025, personally, given all the confusion and all the uncertainty. I'll stop there, but I'm supportive of this motion.

CHAIR BEAL: I think Emilie can answer your question about the timing of the seasons.

MS. FRANKE: Yes, so we do have some states that have a year-round season. Of course, the states on the northern end, of course there is not many cobias around in the early part of the year. South Carolina does have a year-round season. Again, it would be up to the Board.

If there was some sort of middle of 2025 implementation or using the current allocations to do 2025 measures and then switching in 2026, or something like that. It really would be up to the Board as to whether there is enough time to apply any new allocation to 2025 measures. We do have some states that have a year-round season, and then Georgia's season, I believe opens March 1.

CHAIR BEAL: Chris.

MR. BATSAVAGE: Yes, I think just with the timing and the administrative processes that states have, it looks like if we waited until October, we probably won't have something in place until 2025, which means then if we stick to the FMP, at least a couple states will have to take reductions in 2025, unless

These minutes are draft and subject to approval by the Coastal Pelagics Management Board.  
The Board will review the minutes during its next meeting.

the Board gets them on a free pass, which personally I don't support.

I'm kind of torn on this motion. I mean I understand not being in the room is challenging for these hybrid meetings, but we've kind of been in this format for a while now, and for a while we were completely, all on webinar, and we also addressed some pretty big allocation actions like bluefish, and then flounder, scup, black sea bass I think might have been hybrid. You know with the challenges with timing and the fact that we've kind of been operating in this realm for a while. I'm struggling to support this motion at this time.

CHAIR BEAL: Joe Cimino.

MR. CIMINO: Yes, I am in the same boat as Chris. For some reason I seem to always draw parallels with sea bass here. What we had to go through doing hybrid votes for sea bass, when we were coming up with motions on the fly, and all trying to text each other. I don't know that we're necessarily in the same situation here, you know with two states that aren't able to make it. But hopefully I'm in communication.

The other parallel to sea bass here is that it is one of the species that we're constantly setting regulations at the last minute. You know it doesn't make our regulation books, because those get printed earlier in the year, and we do it with fluke too. It's a crummy way to do business. I always feel bad that is how we approach the public. If we end up with a regional approach and the *de minimis* states are moving away from the regulations that they have, then I would like to have the time available to make that known. I really struggle with this motion.

CHAIR BEAL: Ben Dyar online, I see your hand up. Is that a holdover hand or is that a new one?

MR. DYAR: That was holdover.

CHIA BEAL: Okay, thank you. Mel Bell, go ahead, please.

MR. MEL BELL: I appreciate what Chris said, and yes, we've done this before. We've operated in the virtual world. But that was not an optimal situation. Erika mentioned it. I just know from Tuesday, in trying to just coordinate with each other, regarding menhaden discussions. It was extremely difficult, and it kind of felt like we're at a disadvantage.

Sure, if we're all operating like that, that is one thing. But if some states are having to operate with kind of their hands a bit restricted, and other states can operate more freely together, because it is much easier when we're all there. We can talk to each other, we can talk to whoever we need to talk to, and we can argue our case, whatever it might be.

But just because we have done it and lived in that world before, doesn't mean that is an optimal way to operate. I really feel like, from South Carolina's perspective, I feel like we're at a disadvantage, certainly. It is a big fishery for us. I know the public hearing attendance wasn't what many folks would like. Ours wasn't bad.

A lot of the input that was received was from our fishermen, so it is still a big deal fishery for them. I'm going to make sure we're representing them well in their concern. I just feel like given the circumstances that we didn't choose to get stomped on by this storm, and I know folks have been through other weather situations as well.

But we're just kind of regionally at a disadvantage, in terms of our ability to properly participate in deliberations. From my perspective, whether the decision is made now or October, from South Carolina's standpoint, it is going to take us a while to implement what we would need to implement, in terms of changes.

That is really more whether it's now or October, it's going to be about the same if we get things in place. We wouldn't be any worse off, in terms of being able to implement changes if we waited 'til

These minutes are draft and subject to approval by the Coastal Pelagics Management Board.  
The Board will review the minutes during its next meeting.

October. But just feel like those of us that are not there and believe me we really wanted to be there. But things just didn't work out that way and couldn't make it up. I'm in favor of the motion, myself.

CHAIR BEAL: Thank you, Mel, and it's good to hear from you. Other hands online or, Ben, your hand is back up again, is that a new comment?

MR. DYAR: Mel covered what I was going to say, thank you.

CHAIR BEAL: Yes, Eric.

MR. ERIC REID: Yes, I am sympathetic to the three or four states that actually have a fishery for real, that they couldn't communicate with each other, and they couldn't be here. We have been doing this for a long time, and we are only talking about three or four states that had to talk to each other. We've had plenty of time to do it. That being said, I would prefer to move ahead today. Thank you.

CHAIR BEAL: Other comments around the table? Erika.

MS. BURGESS: I've already addressed my motion at the beginning, but I would just like to highlight that this was not a planned absence from the Commission, and this did not give them opportunity to really make their case ahead of the meeting. If they had known months out that they were not going to be here, they might have taken a different approach. Additionally, I would hate to be in the situation that they are currently in and be facing the same prospect where we've got some of the largest participants, traditional participants in the fishery not able to fully participate in deliberations of the management plan.

CHAIR BEAL: Other comments, or are we ready to caucus and vote on this motion? Spud, go ahead, I see your hand online.

MR. A. G. "SPUD" WOODWARD: Thank you, Bob, and thank you for Chairing. Just a couple of comments from my perspective. I know it has been mentioned, well we've had to live in this world before. But I chaired menhaden during the COVID virtual world, and it is fundamentally different when everybody is in a virtual environment versus some in and some not. With all due respect to what Erika had to say, it's one thing to discuss options and possibilities before meetings, but in-meeting dynamics are completely different.

When you're not there to caucus both formally and informally, it is a disadvantage. You know the will of the Board be done, but I think the spirit of the Commission has always been to afford maximum opportunity for coordination and for consideration of other points of view. That is all we're asking in this situation is that we be given the opportunity to be there, so that we can most effectively participate in deliberations on a subject matter that at its best is extraordinary difficult, and that is allocation.

CHAIR BEAL: I'll try John Clark, and then Ben, you have your hand up. I'm not sure, it sort of keeps coming back. I just want to make sure I'm not missing you. John, go ahead.

MR. CLARK: This is very difficult, because I certainly understand what our Commissioners from South Carolina and Georgia are going through. It must be horrible, and then have this decision. But I'm just curious, I mean I have full sympathy. But we have had a lot of time we've been discussing this. Are there new arguments that they've come up with? I understand there are some motions that are probably ready to go here if this is voted down. That they think they could make better in person than they have made already at like previous meetings here?

CHAIR BEAL: Thanks, John, I'm not sure if that is a rhetorical question or a direct question to Board members, or if any Board members want to respond to that.

MR. CLARK: Well, it's kind of not really rhetorical, because I'm just thinking that we have had this

These minutes are draft and subject to approval by the Coastal Pelagics Management Board.  
The Board will review the minutes during its next meeting.

Addendum has been available for months now, and I have heard from different states on this. I was just like I said, just curious if there is something that has changed that they might be able to bring up at the meeting.

CHAIR BEAL: Other hands, other perspectives? Jim Gilmore.

JAMES J. GILMORE: Just a more practical thing. I am having difficulty understanding something. Like when Doug talks, yes when Doug Haymans is talking, I'm having difficulty hearing him, whereas some of the others I can. I mean we start getting into that first section and we start getting into back and forth, it's going to be tough to follow.

As much as I don't like to delay, I think I would support the motion, just because I'm really having difficulty understanding some of what is coming over the PA. Maybe we should get a standard microphone for these guys so that in the future we can really hear them more clearly. Whoever the second person was you can hear very clearly. I mean that is just a technology thing we may want to think about in the future.

CHAIR BEAL: Lynn Fegley.

MS. FEGLEY: I guess Chris Batsavage alluded to this, but I guess what I really want to understand is the negative impacts. We understand the timeline, so it sounds like if we delay this until October, and I am sympathetic to what is happening here. But if we delay until October, it seems to me that what we're going to have for '25 is states that are going to have to make some very substantial changes, and we're going to have turnaround. It sounds like we're going to set ourselves up for some pretty severe regulatory change pretty quickly. I guess I'm maybe facing my colleague in Virginia, or to better understand, what are the impacts of delay?

CHAIR BEAL: Yes, Shanna, do you want to respond?

MS. MADSEN: Yes, so I think some of the concerns that are going around the table right now have me very concerned when there is talk of us potentially using the same allocations for 2025 that we hold right now, whilst we redebate this document. Virginia would take a 50 percent cut if we went ahead and used the same allocations that we have currently in 2025.

I think that I've said this on the record several times that we are at the point right now where Virginia recognizes that no matter what they are going to take a cut. Every single option in this document will lead to Virginia making a management change, and we are onboard with that, and we will do so.

However, that sort of management whiplash that we would have to potentially go through, would be potentially completely crushing for our entire fishery for a whole year. From our standpoint, I do feel for our comrades down in the south that are unfortunately not able to be here in person. However, with the amount of change that we could potentially see from this document, we need the time to be able to react fast. I would not support this motion today.

CHAIR BEAL: David Sikorski.

MR. SIKORSKI: I think Chris used the word free pass earlier. I guess we've done that before. Can anyone speak to the biological ramifications of that because I think we all know the economic.

CHAIR BEAL: Emilie will give it a try.

MS. FRANKE: Just to be very clear with what is being referred to. Last year the Board was considering setting measures for this year, 2024. The TC did do the typical state target our landings evaluation against the targets, but the Board also asked the TC to do another analysis looking at if the Board just stayed status quo in 2024, you know was there a big risk to the stock.



In short, the analysis found, and someone can help me out, because I wasn't actually there for that meeting, if needed, but that there wasn't a big risk of staying status quo in 2024. The Board decided, let's just stay status quo in 2024, let's develop this Addendum and go from there. The Board could potentially discuss that approach, perhaps again for 2025.

I think that maybe Bob or Toni could weigh in, but the FMP doesn't specifically say that the Board cannot sort of do those extra analysis to stay status quo. However, the FMP does lay out this process of doing the target harvest evaluations against the target, and setting measures based on that. I think the Board has to think about just how to move forward for 2025.

CHAIR BEAL: Shanna, do you have a follow up?

MS. MADSEN: I do. Frankly, I don't think that I would support kicking that can down the road and going status quo again in 2025. We're at the point right now where we are pretty unsure of what the *de minimis* states are landing. We are landing a very considerable amount of cobia without taking changes to our management measures. I do think that it is a bad idea for the stock right now. I would not support us staying status quo for 2025.

CHAIR BEAL: Eric Reid.

MR. REID: I didn't mean to hurt Spud's feelings, but it occurs to me that we don't, okay we have people who are not here in person, which apparently, we don't know what their options are, what their discussion points are. But we have motions that are coming to address final action today. I don't know whether or not it would make any sense to table this motion until after we dispose with what's coming, and if everybody is comfortable at that point, what is the point of delaying?

We don't even know what's coming here. We get some motions on the board, we talk about

These minutes are draft and subject to approval by the Coastal Pelagics Management Board.  
The Board will review the minutes during its next meeting.

it, we debate it like we would do, which whether we're in person or not we can still debate it. If we get to a point where everybody is comfortable with that, we just vote it, we move along, as opposed to stopping now, not knowing what is in front of us in the next 5 minutes, 10 minutes, 16.5 minutes, Ms. Madsen, hopefully.

I don't want to make a motion to table and everyone is like, the hell with it, let's just stop now. But that is what I would propose. I don't know how you all feel about that. If you feel like that makes sense, I'll make the motion to table this and we'll move along, and then you can kill it at the end. That is my proposal, but I'm not going to make it unless I get some support for it in a pretty unanimous support.

CHAIR BEAL: I had a couple hands, John Maniscalco, Joe and then Jeff Kaelin. We'll go right down the row then. Go ahead, John.

MR. JOHN MANISCALCO: That does sound like a viable option to maybe debate where we want to go with the Addendum, and perhaps check back in with the states not present in person, to see if they feel as if they can either live with the results and/or if they feel as if they were able to communicate their points with that.

CHAIR BEAL: Joe Cimino.

MR. CIMINO: Ditto.

CHAIR BEAL: That was quick, thank you, Jeff.

MR. JEFF KAELIN: Yes, I think we should move along and work through the motions we have ahead of us, so we can get our regulations in place for 2025. You know why come back here in two months and go through the same material, when the hearings have been over for a couple of months, and we've all chewed on this for a long time, so I'm in favor of moving ahead.

CHAIR BEAL: Erika, go ahead, please.

MS. BURGESS: I don't know if point of order is the right thing in here, but my motion is very specific to deliberation. If we could just vote on this motion, and then I think we could resolve whether we're going to have deliberation or not today. I don't know why you would table the motion to discuss it and then have the same motion, because we've already don't have point of the motion, so if we could just vote on this, I would appreciate that.

CHAIR BEAL: I have one more hand, and then we're going to vote. Shanna.

MS. MADSEN: Erika covered it, thanks, Erika.

CHAIR BEAL: All right, two-minute caucus on the motion on the board. All right, I think we're pretty close to the three minutes. Does anyone else, either online or in the room, need more time to caucus? Seeing no hands; for the couple states that are online that have multiple representatives online, please just vote once, so it will be a lot easier to count these votes. With that, **all those in favor of the motion to postpone, please raise your hand and we'll call out the state names.**

**MS. TONI KERNS: The South Atlantic Council, South Carolina, Georgia, Florida.**

**CHAIR BEAL: All right, if you could lower those hands, it would be great. Those in opposition to the motion to postpone.**

**MS. KERNS: Rhode Island, New York, New Jersey, North Carolina, Virginia, Potomac River Fisheries Commission, and Delaware.**

**CHAIR BEAL: Are there any abstentions?**

**MS. KERNS: NOAA Fisheries.**

**CHAIR BEAL: Any null votes? Maryland has a null vote. The motion fails for lack of majority, 4 to 7, 1 and 1.** With that where does the Board want to go? Ben, you have your hand up, are you going to help us move along?

MR. DYAR: Yes, I have another motion, thank you, Mr. Chair, that I would like to make.

CHAIR BEAL: Yes, go ahead, please.

**MR. DYAR: I move to postpone final action on Addendum II until the Board receives the presentation of SEDAR 95 results and receives Technical Committee recommendations on applying SEDAR 95 to management, including recommendations for the total harvest quota.** If I get a second, I can make comments.

CHAIR BEAL: Is there a second to that motion? Erika, are you seconding? Ben, do you have any additional comments on the motion?

MR. DYAR: Yes, Mr. Chair, thank you. The most recent cobia assessment that was completed in November of 2019 had a terminal year of 2015. Although stock status indicated the stock was not overfished or undergoing overfishing, since that terminal year, as noted recently, Mid-Atlantic states have recorded increased levels of harvest, including some non *de minimis* states, while southern states harvest have stayed relatively stable, potentially indicating an expansion of the range.

This increase in harvest has led to exceeding the coastwide target by 18 percent in three of the last six years. There has not been a stock status determination encompassing this same timeframe to account for these changes. Furthermore, harvest levels, allocations and soft targets were established, and projections created in the previous stock assessment that had low probability for the stock being overfished through 2024, nor did it project a decline in the spawning stock biomass.

But the previous stock assessment could not have accounted for this level of increase in harvest or effort. Before allocating harvest towards one of the stocks largest spawning aggregations, the stock status determination seems prudent. Cobia tick nearly all the boxes for a hyper stability fishery, which is exactly what we went through and witnessed in South Carolina.

These minutes are draft and subject to approval by the Coastal Pelagics Management Board.  
The Board will review the minutes during its next meeting.

For a minute, just kind of giving some background. There were high levels of skilled effort, charter captains and tournament fishermen, which were directed seasonally on a main spawning aggregation. This was our genetically distinct cobia population we have in South Carolian. This was done without supporting independent data.

This led to catch numbers being relatively stable, and then basically falling off the cliff within a 3-to-4-year time span and ultimately crashing. We have currently then set in 2016, set management measures to close state waters during that spawning run of cobia, and we have a cobia stocking program. Seven years later, we are still not clear on the status of that stock. That is not to say that this would happen or is currently happening with the Cobia Atlantic Migratory Group. I have no evidence to allude that this is the case and realize that it is on a much larger scale. But this is something that we should as a collective body in managing this stock, should be attentive to. Something that I feel important that we should always bring, I should have brought forward and note, that not just for this Addendum, but in future management for this fishery, and the need for independent data.

A second point, and one that was noted in the public comment and by the AP. Allocation options in the Addendum have a likelihood of requiring immediate management changes, which will potentially need to be revisited with just in two years, based on the outcome of the benchmark stock assessment.

This contrasts with some of the options in the Addendum, as it includes options to increase the timeline for setting major measures with a goal to decrease management whiplash, and to better align with the new stock assessment information. The goal of this motion is to preserve the work of the PDT and the Addendum II document, as they have beneficial options that address the difficulties in managing a data poor fishery.

These minutes are draft and subject to approval by the Coastal Pelagics Management Board.  
The Board will review the minutes during its next meeting.

I fear that moving forward with immediate changes to allocations without exhausting all the tools allowed to us as managers, would not be in the best interest of the resource, feeling it would be cleaner for management changes that the document is taking as a whole, and revisited once we have management recommendations resulting from the ongoing stock assessment that accounts and incorporates the changes we have seen in the fishery since this last stock assessment. Thank you.

CHAIR BEAL: Erika, as seconder, do you have anything to add? She does not. Any other comments? Chris.

MR. BATSAVAGE: This question is for Ben. If the stock assessment doesn't pass peer review, what is the status of this Addendum? Can we move forward or is the action on this Addendum dependent on the assessment passing peer review?

CHAIR BEAL: Ben, do you want to respond to that?

MR. DYAR: Yes, I do, Mr. Chair, thank you. Chris, good question, thank you. That was taken into account when trying to formulate this motion, and that it doesn't necessarily hinge on the assessment passing peer review, just that there would be recommendations from the TC regardless.

If it did not pass peer review there would still be recommendations to either utilize the same total harvest quota as we have in the past, or whatever that might be, barring not passing peer review, or hopefully as it would pass peer review. If I'm misinterpreting that, please, Emilie or someone correct me.

CHAIR BEAL: Other comments around the table or online. Joe.

MR. CIMINO: I have been giving this a lot of thought, both MRIP recalibration and the idea of the assessment. Reallocation is a very difficult decision. We have a chance here to do this kind of a priori, right. Like we do this based on what we believe is the best formula, regardless of whether or

not it is more painful or less painful, based on what we see where the stock is at. I almost don't see the connection for the two. Yes, we will have to respond to this assessment, and I very much hope it passes. That happens regardless. To move us into the current timeframe, and away from something that was happening a decade ago, and isn't reflective of the management system that we're in now, I also think happens regardless of the assessment. I can't support this motion.

CHAIR BEAL: Other comments? John Clark.

MR. CLARK: Just a question. What is the timeframe of this SEDAR 95, and when would the recommendations be coming? Couldn't we complete the Addendum now, and then just change things either through an addendum or if the other option passes for Board action, do things at the time when this comes through?

MS. FRANKE: Yes, so SEDAR 95 is anticipated to be complete near the end of 2025. I'm not sure if it would be done in time for the Board to receive the presentation at the 2025 annual meeting. It might be that the Board receives the presentation at the January or February 2026 meeting, so maybe it could inform 2026 management, maybe the soonest it could be used is 2027. Can you repeat the second part of your question?

MR. CLARK: Well, I think that answers it. I was just curious as to why we, I was thinking like if we go with an option now based on the Addendum, we would always have the ability to change it once we do get this, because you're talking way off into the future now. Okay, thank you.

CHAIR BEAL: John, we're trying to keep that for the annual meeting in Delaware, so there is some excitement.

MR. CLARK: Isn't Wilmington exciting enough?

CHAIR BEAL: That's a good point. Other comments on, yes, Shanna.

MS. MADSEN: It will surprise no one that Virginia is not going to support this motion. I've heard comments today kind of to the effect that if we wait until SEDAR 95, we are avoiding management whiplash. I think we're increasing the likelihood of us actually going through management whiplash, quite frankly. Either way, any option in this document, including status quo, requires many of the states to change their management measures.

We're having issues with our *de minimis* states popping in and out of *de minimis*. We have no way of actually addressing that unless we do something in this document today. We have two states that are over their soft target, so they will also be changing their management measures. Management whiplash is going to occur if you pass this motion. I will not be supporting this motion today.

CHAIR BEAL: I have one hand online, Doug Haymans, and I think we're quickly getting to the point where more debate on this may not change anyone's mind. I'll let Doug have the last comment, and then it will be time to vote on the motion. Go ahead, Doug, please.

MR. HAYMANS: I guess to Shanna's comment I would ask; you know these are soft targets in a fishery, it's not overfished, not undergoing overfishing. Yet if I read soft target right, from the document it means that management measures are adjusted to reduce harvest to the target. Since 2021, Virginia has not changed its regulations, even though it has exceeded every year.

I can see that every year since 2024. I hate to go out of compliance, because I don't see us changing our regulations based on PSEs under 50 percentile, so if anything, it seems to me that the states that are doubling their quota should be the ones that have changed their regulations over the last three years. I will be voting in support of this motion.

CHAIR BEAL: With that, we'll do a two-minute caucus, I don't think we need the full three. Then we'll vote. We're at the two minutes, so with that **all Board members in favor of the motion to postpone final action, please raise your hand.**

**MS. KERNS: Florida, Georgia, South Carolina.**

**CHAIR BEAL: All right, please lower those hands. All those in opposition to the motion to postpone, please raise your hand.**

**MS. KERNS: Rhode Island, New York, New Jersey, North Carolina, Virginia, Potomac River Fisheries Commission, Delaware.**

**CHAIR BEAL: All right, any abstentions?**

**MS. KERNS: NOAA Fisheries and South Atlantic Council.**

**CHAIR BEAL: Any null votes? I'm looking at you, Maryland, null votes.**

**MS. KERNS: Maryland.**

**CHAIR BEAL: Great, thank you. The motion fails for lack of majority, 3 in favor, 7 in opposition, 2 abstentions and 1 null vote.** That brings us to a really good point to take a break, I think. Let's take about a five-minute break, and then we'll see where we go from here.

(Whereupon a recess was taken.)

CHAIR BEAL: All right, looks like everyone is back in the room, maybe not quite back in their seats, but close enough. We're going to get started. What is the Board's pleasure? Where do you want to go from here? Shanna.

MS. MADSEN: I would like to get a motion up so we can start to have some conversation on it. I am going to start with Issue 3.1. My motion is, **move to adopt for Issue 3.1 recreational allocation framework, a combination of Option C4, northern regional**

**allocation for Rhode Island, Connecticut, New York, New Jersey, Delaware, Maryland and Virginia, and Option B2, state allocations for North Carolina, South Carolina and Georgia, with allocations based on 50 percent of 2014 to 2023 landings, and 50 percent for 2018 to 2023 landings, excluding 2016, 2017, and 2020.** If I can get a second, I will speak to that.

CHAIR BEAL: Is there a second for the motion? Jason McNamee. Go ahead, Shanna, please.

MS. MADSEN: This action that I have before us I think remains consistent with a lot of the comments that folks around the table have heard me make in the past year or so. Our MRIP uncertainty still remains high, and I've really tried to support this move away from state-by-state allocation. But I did want to recognize that our southern neighbors have some differing management measures that they would like to maintain.

I'm trying to attempt a compromise to support their fisheries with this motion. In this motion, *de minimis* states are going to be captured in those harvest estimates for MRIP and our PSEs should be better grouping up as a region. I went with the longer historical timeframe that continues to acknowledge historical landings, but also more accurately representing the expansion of the stock. That is what I've got.

CHAIR BEAL: Jason, do you have any additional comments?

DR. JASON McNAMEE: I'll be quick, Shanna did a nice job, so I'll just add it. I agree with her characterization, it seems like a really nice compromise, and the original approach for the northern extent of the stock, I think is becoming increasingly important. You know as we're seeing fish up in Rhode Island, that is why we're sitting at the table.

It is intermittent at this point, but it's becoming more frequent. To be involved in the management in a way that we wouldn't have to come back to the table at some point scrapping for allocation. You

These minutes are draft and subject to approval by the Coastal Pelagics Management Board.  
The Board will review the minutes during its next meeting.

know I think this regional approach does the trick of kind of looking up to the north, looking to the future a little bit for the stock.

CHAIR BEAL: Other hands around the table? Chris, and then I see Doug Haymans online, so go ahead, Chris.

MR. BATSAVAGE: Yes, I support this motion. As has been stated plenty, the cobia stock has changed a lot in terms of timing and distribution. This motion addresses it, especially for the *de minimis* states, where we know there are more fish being caught north of Virginia, so allocating 5 percent of the RHL is appropriate, as opposed to 1 percent.

Yes, this will shift a lot of the allocation to Virginia, and we heard concerns from Board members and the public on that. It will shift allocation away from the states south of there. However, as Emilie shared in the presentation, it doesn't necessarily mean that the states losing allocation will need to make management changes on this. I think another important point, two other important points to think about. If we did make this change with more current years is the base years we're using, the base allocations on. We're at a time where we had much more liberal regulations, it was a 33-inch size limit, 2-fish possession limit, no vessel limit, year-round season. But we're probably not going to have regulations like that again. The other point is, at least North Carolina, the fish they aren't there like they used to be. Instead of a 6-to-8-week season, it is sometimes only a week, sometimes it's maybe 4. Although it's I think it's probably just maybe more for stakeholders in my state that are concerned about a shift in allocation.

This is maybe more reflective of just how the fishery is operating now, and how the fish are distributed. Just one final thing, just about allocations in general. I think at the Council and ASMFC level, we're not setting allocations for 20 years anymore. Yes, I think we've all realized if we need to revisit allocation decisions on a

fairly regular basis, and I see this with cobia as well. That's it.

CHAIR BEAL: Doug Hayman, go ahead, please.

MR. HAYMANS: I would like to offer a substitute motion, please.

CHAIR BEAL: Yes, go ahead.

MR. HAYMANS: I would **move that we adopt A, status quo, until the SEDAR 95 Stock Assessment is complete.**

CHAIR BEAL: Is there a second to that motion for status quo in Section 3.1? I see Ben Dyar's hand went up first, there is another hand as well. Ben has seconded it, Doug, would you like to comment in support of your motion?

MR. HAYMANS: Sure, we're working with a fishery that is not overfished or undergoing overfishing. We've been fishing that at the same levels for about the last six years, and there hasn't been tremendous outcry over the levels at that point. We haven't enforced the south's quota to this point in the states that continue to overfish. I do not see the harm in continuing the level of harvest that we have now, until the time that the stock assessment is complete.

CHAIR BEAL: Ben, do you have any comments relative to the motion?

MR. DYAR: Yes, echoing some of my sentimental statements in the motion I had to postpone, this concerns allocating more resources until we have more information through some type of stock assessment through these changes in effort that we've seen. But also, in regards to the motion.

In some of my comments from our constituents in South Carolina, concerns again with us closing areas, a season closure for our spawning stock aggregation in South Carolina having that affect our harvest levels, and therefore our quotas in these allocations are a concern. Then having to take even more cuts with this potential motion that Shanna

These minutes are draft and subject to approval by the Coastal Pelagics Management Board.  
The Board will review the minutes during its next meeting.

made. For that reason, I am in support of status quo.

CHAIR BEAL: Emilie has a comment.

MS. FRANKE: I just want to clarify, and just make sure the maker of the motion is aware that since the motion says until the SEDAR 95 stock assessment is concluded, that just means that the Board would be required to at least talk about allocation when the stock assessment is complete.

CHAIR BEAL: Comments around the table, John.

MR. CLARK: Emilie, I'm just curious as to, just to visualizes in my head again, can you put up that table you had before that showed with the main motion that is up there right now, not the substitute, what the actual impact would have been based on last year's landings.

CHAIR BEAL: Staff is working on getting that up there, John, any other comments while they're working on that? Yes, John, the other John, Maniscalco.

MR. MANISCALCO: I can't support this motion, status quo doesn't provide any of the *de minimis* states with data that could be used to determine allocations, given that status quo stopped in 2015, I believe, and many of the *de minimis* states have little to no useable MRIP estimates of landings from which to base an allocation upon, in the event that we exceed 1 percent.

CHAIR BEAL: Other comments around the table? I see Doug's hand is back up, so go ahead, Doug, please.

MR. HAYMANS: To John's comment a moment ago. I don't think that's going to change whether the northern states get allocation or not. MRIP is still going to be off the charts and unusable. Again, the northern states that are *de minimis* have continued to harvest, and there hasn't been a penalty applied with their

overages, and I don't believe there will be one applied, even if we stick to those. I'm sorry, we stick with status quo. There is not going to be a penalty applied and they will continue to be able to fish.

CHAIR BEAL: Emilie, do you want to explain the figure that is up on the screen now, relative to the main motion, prior to the motion to substitute.

MS. FRANKE: Sure, I had a request to pull this table back up, so this table shows if you apply the allocation percentages for the state-by-state options to our current 76,908 quota regime, these are the state targets you would get. In the main motion made by Ms. Madsen, you can see that would be Option B2 for the southern states, so North Carolina, South Carolina, and Georgia.

Then in the gray column you can see the average harvest for the last three years that would be used in the evaluation. For example, Georgia's new target under B2 would be 4,647 fish, and their average harvest the last three years has been 8,840 fish. Again, the main motion this would apply to Georgia, South Carolina, and North Carolina.

CHAIR BEAL: Great, thanks, Emilie. Other comments around the table? Doug, your hand is still up, is that just a leftover? All right, thank you. Any other comments around the table on the motion to substitute or the main motion since we're sort of debating these at the same time. Seeing none; let's caucus for two minutes and we'll vote on the motion to substitute. Is everyone ready to vote? Not seeing a need for more caucus time. Just as a reminder, the **Board is about to vote on the motion to substitute to adopt Option A for Issue 3.1. All those in favor of the motion to substitute, please raise your hand.**

**MS. KERNS: South Carolina, Georgia, Florida.**

**CHAIR BEAL: All right, we can lower those hands, please, all those opposed to the motion, please raise your hand.**

These minutes are draft and subject to approval by the Coastal Pelagics Management Board.  
The Board will review the minutes during its next meeting.

**MS. KERNS: Rhode Island, New York, New Jersey, Delaware, Potomac River Fisheries Commission, Virginia.**

**CHAIR BEAL: All right, any abstentions?**

**MS. KERNS: NOAA Fisheries and South Atlantic Council.**

**CHAIR BEAL: Any null votes?**

**MS. KERNS: North Carolina and Maryland.**

**CHAIR BEAL: The motion fails for lack of majority, 3 in favor, 6 in opposition, 2 abstentions and 2 null votes.** That brings us back to the main motion. Is there any more debate on the main motion or are folks ready to have a one-minute caucus and vote? Ben, I see your hand up, do you have a comment?

MR. DYAR: Yes, Mr. Chair. I think I would like to offer a secondary motion.

CHAIR BEAL: Ben, did you say you want to make a substitute motion?

MR. DYAR: Yes.

CHAIR BEAL: Go ahead, Ben, please.

MR. DYAR: **Move to adopt for Issue 3.1 Recreational Allocation Framework Option C4 for Rhode Island, Connecticut, New York, New Jersey, Delaware, Maryland, Virginia, as well as North Carolina, South Carolina and Georgia with the weighted 10 year and 6-year average, 50 percent of the 2014 -2023 landings and 50 percent of the 2018-2023 landings, excluding 2016, 2017, and 2020.**

CHAIR BEAL: All right, thanks, Ben, we're getting that motion up on the board. While we're getting it up there, is anyone comfortable seconding that now, or do you want to see the text. There is the text. Go ahead and second that motion. I don't see a hand for a second, so that motion fails for lack of a second. Oh, Doug,

your hand was up. Was that to second the motion?

MR. HAYMANS: Yes, that is a second.

CHAIR BEAL: Eric Reid has a point of order, go ahead.

MR. REID: Yes, point of order, Mr. Chair. When you have a main motion and a motion to substitute, the procedure is you perfect both motions and then you dispose of both motions before you can take another motion. That is the way I see Robert's Rules, that is the way we use it. The second motion as substitute would be inappropriate at this time. That is my opinion.

CHAIR BEAL: The way we've been doing it at the Commission is allowing for multiple substitutes under the main. I think we'll go forward with this motion to see where it goes, and we may come back to your point. But I think **where we are is we have a motion from Ben Dyar, essentially adopting or substituting the main motion with Option C4.**

Is there any need to caucus on this, or are folks ready to go? Caucus, all right, one-minute caucus. For those online we're, obviously that was a lot longer than a one-minute caucus. We're trying to work through one technical question that has come up. While I saw Doug Hayman's and Ben's hand up before we went into caucus, or right as we went into caucus, and they've gone down now.

But I did not give either of them, which I should have, the opportunity to talk in support of their motion. I should have done that, so I'll do that first, starting with Ben then go to Doug, and then while they are speaking, we are going to continue to work on the question that has come up, sort of in the room, and then we'll explain where we are with that after Ben and Doug make their comments. Ben, go ahead, please, and then we'll go to you, Doug.

MR. DYAR: Yes, that is why I had my hand raised, actually, so I appreciate that. **The motion to substitute is for region, for North Carolina, South Carolina, Georgia.** The document, one of the main

These minutes are draft and subject to approval by the Coastal Pelagics Management Board.  
The Board will review the minutes during its next meeting.



points the document tries to address is the concerns for PSEs and the data. When looking at, I don't know if we had that slide that was just up back up, but it kind of gets at that with the harvest numbers if you go state by state.

Georgia having to take almost a 50 percent potential reduction immediately, I know all this can change in the future, but that is what we're looking at, and then South Carolina having to take a reduction as well, with Georgia having in the last, since 2018 not having any PSEs below 30, and only one of those years, so 5 out of the last 6 years they have been above 50 in their PSEs, and South Carolina has had 3 out of the last 6 above 50 as well, and no years below 30.

Having to take 50 percent reductions in Georgia and taking reductions in South Carolina with PSEs at that level, it makes it very difficult. When we got to go in South Carolina, in the timing of things in South Carolina, we do not have a Commission, we are legislatively managed in all of our fisheries, so choosing to change size limits or bag limits or seasons we have to go through the full legislative process.

That doesn't commence until July the next year, so you know when we're talking about trying to make these nimble changes, and any changes based on high level PSEs, we have to try to explain that to our legislatures, and that makes it very difficult to base those management changes on. When you look at the PSEs provided in the document for the region, the southern region, they get no PSEs are above 50 in that C4 option, and some years even being below 30. That is one main reason I think that this document was trying to address not only the changes in harvest in recent years, in different regions, but also the high-level PSEs, and specifically this unique fishery, this pulse fishery. Again, that I mentioned it has kind of the potential for hyperstability and fear that we would be heading down that road. Thank you.

CHAIR BEAL: Doug, do you want to follow up?

MR. HAYMANS: I was just echoing Ben's comments. I agree, and that's why I had my hands up. That option would provide the least risk to PSEs. I echo Ben's comments.

CHAIR BEAL: There was one question about a number in one of the tables associated with one of the options, and I think staff is correct on where we are, and Emilie can explain it now. Thanks, Emilie.

MS. FRANKE: I just had a question or someone had a question about sort of looking at the percent allocations for the regional options, and noticed, you know if you look at for example, C4. The southern region gets 31.31 percent. Then when you look at the state-by-state table and add up North Carolina, South Carolina, and Georgia, it only adds up to 30.5 percent. That is because the calculations for the percent allocations are slightly different for state by state versus regional.

That is because for state by state the *de minimis* comes off the top. For those four Virginia, North Carolina, South Carolina, and Georgia, we're looking at those four states on their own, what the proportion of each of those states for that four-state total, and then we take 5 percent off the top for *de minimis*. It's a little bit different. For the regional approach we look at what's the coastwide total and just what is the percent for each region. I double checked, triple checked the math, I promise it's right. I almost had a heart attack, but we're fine.

CHAIR BEAL: All right, deep breath, everything is okay. All right, any other? I think we've caucused, or everyone has caucused, and we've given the opportunity to the maker and the seconder to comment. Is there any need for additional caucus time now that you've heard those comments of the maker and seconder? I don't see any, so we're going to go ahead and vote. **All those in favor of the motion to substitute, please raise your hand.**

**MS. KERNS: Rhode Island, New York, New Jersey, Florida, North Carolina, Virginia, Potomac River Fisheries Commission, Maryland, Delaware, South Carolina, Georgia.**

These minutes are draft and subject to approval by the Coastal Pelagics Management Board.  
The Board will review the minutes during its next meeting.

**CHAIR BEAL: Thank you, could you lower those hands. Those in opposition, please raise your hand. Seeing no hands around the table, abstentions.**

**MS. KERNS: NOAA Fisheries and South Atlantic Council.**

**CHAIR BEAL: Any null votes n-u-l-l? Look at that, the first vote without a null vote, we're making progress. That motion carries 11 in favor with 2 abstentions and no votes in opposition. That becomes our main motion.** I assume, I hope there is no need to caucus on this one. Is everyone ready to vote?

Let me try this and see if I can get away with it. **Is there any opposition to this motion? Seeing no opposition, is there any abstentions for voting on this motion? I see no abstentions or opposition, so this motion carries.** That is Section 3.1. Are there any other motions to move us along with the document? Yes, Shanna. Well, actually, Shanna, Spud has his hand up. I'm not sure if it's a question about what just happened or if he has another motion, so Spud, go ahead, please.

MR. WOODWARD: I've got a question. If we have made a decision to go to regional management, and all of the *de minimis* states are in the north region. Shouldn't the *de minimis* quota be taken off of that regional allocation and not the overall? It's a question.

MS. FRANKE: Thanks, Spud. For the regional calculations, the calculations have nothing taken off the top. That northern region accounts for all of those states. There was no taken off the top calculation for the regional. That taken off the top calculation was only for the state by state.

CHAIR BEAL: Are you okay, Spud, with that explanation?

MR. WOODWARD: I guess so, I've got to ponder on it. Thank you.

CHAIR BEAL: I'll go back to Shanna; you had your hand up before that.

MS. MADSEN: I'm going to make an attempt to make a mega motion, we'll see how this goes. The mega motion I have is **move to adopt for Issues 3.2, Updates to State and Regional Allocations - Option B, Allocation Changes via Board Action. Section 3.3 Data and Uncertainty in Recreational Landings Evaluation – Option B Extend the Rolling Average to Five Years, 3.4 Overage Response for Recreational Landings Evaluations - Option A Status Quo, and 3.5 Timeline for Setting Commercial and Recreational Measures – Option B Five-Year Specifications.**

CHAIR BEAL: Is there a second to Shanna's mega motion? John Maniscalco, thank you. Shanna, do you want to explain?

MS. MADSEN: I guess I'll go through each one of these and kind of talk through what my justification or thought process was. For Issue 3.2, I selected Option B to allow the Board some flexibility in being able to update allocations with those calibrated numbers from MRIP. It does not force the Board to necessarily do things that way but does allow us a little bit of flexibility to be able to address that issue.

For Issue 3.3 I chose to extend the rolling average to five years, again my thought process here was to address yearly variation in MRIP estimates, as well as allow us in the future the option a few things of confidence intervals, which I think really is the future management of this fishery that we're looking for. For Issue 3.4 I selected Option A, status quo, and I did this to protect stock. I think having regional allocations and those longer rolling averages should help us to smooth out variation. I don't think it's a good idea for us to go borrowing from other regions, in this case it is in the best interest for the conservation of the species, and for Issue 3.5 I selected Option B, five-year specification setting. I was doing this in hope of getting us in line with the assessment schedule and the landings

These minutes are draft and subject to approval by the Coastal Pelagics Management Board.  
The Board will review the minutes during its next meeting.

evaluations, while once again trying to smooth out those large swings in recreational estimates.

CHAIR BEAL: Thank you, Shanna. John, do you have any follow up comments?

MR. MANISCALCO: Shanna said it well, you know allow the Board to be nimble, pay attention to the quality of the data that we are working with, being responsible to the stock, and also to hopefully align us in order to be able to react to stock assessments.

CHAIR BEAL: Yes, Joe.

MR. CIMINO: A question for Emilie. Emilie, can you bring us back to 3.2 B, since as you mentioned. Well, if we just voted to get rid of *de minimis* then what are the situations in which the Board would be looking at this?

MS. FRANKE: Sure, for Section 3.2 this is the option for the Board to update the, in this case regional allocations via Board vote, instead of an addendum. Originally there were two specific scenarios the Board could use that Board vote ability. The first is if a state came out of *de minimis* and needed their own state harvest target.

However, we're now in regional allocation, so that scenario is no longer applicable. Now, the other scenario where the Board could make a change to allocation percentages via Board action is if the harvest estimates for the allocation source data are revised. In a couple years if MRIP says, our time series has been updated, then the Board could look at that revised time series that would impact those percentages and make those changes via Board vote instead of an addendum.

CHAIR BEAL: Just for clarity, I want to make sure that everyone is on the same page that I am now, is Option B for Section 3.2 doesn't give the Board the ability to move from state by state to regional and regional to state by state. The previous motion that was passed was

regional, and if this were to pass that gives the Board the opportunity to move regional allocation but doesn't allow the shift to a different allocation scheme altogether. Just want to clarify that on the record. I had Lynn, and then Ben Dyar online, so go ahead, Lynn.

MS. FEGLEY: I was going to ask for the same clarification, but also, I wanted to clarify for the record that Option B wouldn't preclude the Board going to an addendum if they really felt like they needed to. It just allows them to take Board action if it's appropriate.

CHAIR BEAL: Yes, that is correct, and toward the end of the motion there is a notion of setting five-year specs, and it is sort of up to five-year specs. If the Board didn't feel comfortable with that and they want to set three, that is fair as well. Just providing sort of the maximum flexibility for the Board should they chose to use that, the way I view this. Ben Dyar, go ahead, please.

MR. DYAR: Just clarification, apologies for not fully understanding. The second bullet, that would not include, that would specifically be for harvest estimates, or would that include any changes in allocation for a stock assessment, so the Board would be able to make those changes as well, or would that again have to go through, that would be done through the TC and their management recommendations, is that correct?

MS. FRANKE: Correct. For that second bullet this is the scenario when the Board could use this Board action, harvest estimates for allocation source data are revised. That is only if the MRIP time series is revised. Based on the vote that just happened, our source data for allocation are 2014-2023 MRIP data. If MRIP changes the estimates for that time series, then the Board could use this Board action to update the allocation percentages accordingly. This does not give the Board the ability to change allocations based on the stock assessment, that would be an addendum.

CHAIR BEAL: Other hands, yes, John.

These minutes are draft and subject to approval by the Coastal Pelagics Management Board.  
The Board will review the minutes during its next meeting.

MR. MANISCALCO: Just to clarify though. If a stock assessment suggested a different catch limit is appropriate, that would be advice from the TC that would automatically be implemented, right? That would not require an addendum to adjust.

MS. FRANKE: Correct. I guess just to clarify, there are sort of two separate things we're talking about here. We're talking about allocations, which is the percent each region gets, so that is what this option is addressing. That is addressing the potential changes to the MRIP historical time series. When we're thinking about the stock assessment, which would potentially tell us what the total quota should be for the coast, that is something separately in the FMP the Board can already set via a Board action.

CHAIR BEAL: Other comments. Doug, I see your hand up, go ahead, please.

MR. HAYMANS: A question, if we combine regionally, that means that each of the states within the region need to come to the same management measures with the exclusion of seasons. I think that is right. Does that mean that Rhode Island through Delaware have to match Virginia's 40-inch total length, or does Virginia have to come down to the 37 inches? I'm trying to figure out what the implications are.

MS. FRANKE: Absolutely, thanks, Doug. That is for the region to decide. After this meeting we have the regional allocation that northern regions average harvest has been over that northern regional target, so those states in the region are going to have to get together, you know via the Technical Committee, to figure out what the size limit and vessel limit should be for every state in that region. It could be that all the states end up, maybe at Virginia's current size limit, it could be maybe a size limit in between. That is for the TC and the states to figure out, but yes, all those states.

MR. HAYMANS: If I may, a follow up. Then the TC recommendation comes back to the Board, so the southern region gets to vote on the northern region's management measures and vice versa.

MS. FRANKE: Correct, so the FMP is set up so any recommended changes to state measures are considered by the Board. That is how it currently is as well for the state-by-state allocations. If states have had to change their measures in the past the Board has had to vote on that.

MR. HAYMANS: Okay, thank you.

CHAIR BEAL: Other comments or questions. Are we ready for a caucus on this? I see no other hands, let's go two-minute caucus and we'll take a vote.

MR. HAYMANS: Bob, I'm sorry to interrupt the quiet in the room, but could we possibly get a few extra minutes on that caucus, please, it's pretty difficult to text between all of our constituents on this end.

CHAIR BEAL: Yes, fair enough, Doug, we'll give you a couple more minutes, and then I'll check back in with you to see if you need more time. Doug Haymans, I'm just checking in to see how you're doing and see if you need some additional time.

MR. HAYMANS: Well, I think what I need, Sir, is a clarification on Option B regarding confidence intervals. Is that rolled in as if under Option B or is it not? I'm not clear. I can't get my compadres to clear it up for me.

MS. FRANKE: Sure, so the question is for Section 3.3, Option B, which extends the number of years used in the rolling average for harvest target evaluations. The confidence interval is a separate piece that is part of Section 3.3. Selecting Option B does not require the Board to move to confidence intervals.

Basically, Addendum II just has that option, that provision in there that allows the Board to switch from a rolling average to confidence intervals when the Board sees fit. It is not tied to selecting Option

These minutes are draft and subject to approval by the Coastal Pelagics Management Board.  
The Board will review the minutes during its next meeting.

B. Until the Board says otherwise, we're going to continue to use this rolling average approach, and Option B would allow up to five years to be used for the rolling average.

MR. HAYMANS: Okay, thank you.

CHAIR BEAL: Doug, does that indicate you are ready to vote, or you need another minute?

MR. HAYMANS: I guess I am ready to vote.

**CHAIR BEAL: Those in favor of the motion that is up on the board, please raise your hand.**

**MS. KERNS: Rhode Island, New York, New Jersey, North Carolina, Virginia, Potomac River Fisheries Commission, Maryland, Delaware, South Carolina.**

**CHAIR BEAL: All right, please lower those hands. Those in opposition.**

**MR. HAYMANS: I'm sorry, Bob, I went the opposite direction, my hand is raised in support.**

**CHAIR BEAL: All right, we will record Georgia as in support of the motion, thanks, Doug. Okay, is there anyone in opposition to the motion? Any abstentions?**

**MS. KERNS: Florida, NOAA Fisheries, and the South Atlantic Council.**

**CHAIR BEAL: I believe that is all the votes, so there shouldn't be any null votes, is that correct? All right, that motion carries, 10 in favor, 0 in opposition, and 3 abstentions.** We have one clarification on how the regulations will work within the regions, and Emilie will make that, and then we'll carry forward with approval of the document.

MS. FRANKE: Great, so yes, I just wanted to go back to Doug's question, just to again clarify for the record how this regional allocation will work. All of the states in a region, you know

right now states have differing regulations. When a reduction is needed, or after the next stock assessment, whichever comes first. All states in a region are required to come to the same vessel limit and the same size limit.

Because, as you saw on table earlier, that a reduction is going to be needed in the northern region, all those northern region states will be required to come up with the same size and vessel limit for next year. For the southern region, North Carolina, South Carolina, and Georgia, because a reduction is not needed at this time, those states can all stay status quo for now, until a reduction is needed in the future or until the next stock assessment. I hope that is clear, if you have any questions, let me know.

CHAIR BEAL: John, go ahead.

MR. CLARK: But the northern region states can still have different seasons, correct?

MS. FRANKE: Yes, correct.

CHAIR BEAL: John Maniscalco.

MR. MANISCALCO: This question is on a different matter if that is okay.

CHAIR BEAL: Is everyone okay with what Emilie just described? All right, seeing none, go ahead, John.

MR. MANISCALCO: I am just curious as to what it would take for the Technical Committee to kind of start considering how they would approach this confidence in full process, rather than, I almost don't see any reason why we should consider point estimates. Moving forward if we have the ability to look at utilized confidence intervals. I would like the TC to start thinking about how they would implement that then.

CHAIR BEAL: Is the Board comfortable with, Jason, go ahead and comment on that, then I'll go back to my question.

These minutes are draft and subject to approval by the Coastal Pelagics Management Board.  
The Board will review the minutes during its next meeting.

DR. McNAMEE: I maybe put my hand up too quick, because I was just going to support it. I think that is a great idea. I think there are some options, like there are some bells and whistles to tinker with on the approach. For instance, what confidence limit, what metric are we using for the confidence limit, 96 percent, 80 percent? There are like some options in there that I think we need to see and think about a little bit, but I would like to start by seeing and thinking about that, so I'm supportive of thinking about this in some way.

MS. FRANKE: Yes, so I think if it sounds like the Board would like to task the TC while they are doing the analysis to determine the measures for the northern region, the TC can also discuss the confidence interval approach, what that would look like for the regional approach that was selected. Two things to point out.

The confidence interval approach does specify 95 percent confidence intervals already, and the second thing, just to remind folks that will be part of the TCs discussion is, if you have a year with a harvest estimate that has a PSE between 30 and 50, the TC sort of has the ability to discuss whether or not the approach would be appropriate for that year.

That would be part of the TC discussion. But I think we can bring all of that back to the October meeting, the discussion of the confidence interval approach, as well as the analysis of potential northern region measures. As I mentioned, right now the rolling average approach indicates that the northern region needs to take a reduction.

If for some reason the confidence interval approach indicates a different outcome, then again, we can bring all of that to the October meeting, and the Board can discuss how to move forward, and whether to use the confidence interval approach. I think if you basically bring all analysis to the table.

CHAIR BEAL: Jason and then Toni.

These minutes are draft and subject to approval by the Coastal Pelagics Management Board.  
The Board will review the minutes during its next meeting.

DR. McNAMEE: I'm fine if Toni wants to go first.

MS. KERNS: Just a reminder that when the TC was trying to work through the confidence interval approach, they could not reconcile some issues with the SAS code, and so they may or may not be able to address that between now and the October meeting, because they are going to have a pretty big lift anyway, bringing forward recommended management measures. It may take a little bit longer than just the next meeting as it adds up, but we'll see what we can do.

CHAIR BEAL: Jason.

DR. McNAMEE: Yes, and just I'll throw a response. That is fine with me, like I'm not feeling like the house is on fire when you could do this now. In fact, I think we should slow walk it a little bit and ensure we're comfortable. That is actually my question. I recognize that it was specified in the document, but I guess what if we wanted to change that? Is it another document that would need to be produced, because I don't know, I am thinking people might want to think about that a little more, the actual size of the confidence limits.

CHAIR BEAL: Yes, Jason, I think for better or for worse it will probably take a new addendum, because the draft addendum specifically stated the 95 percent confidence intervals. Ben, you have your hand up, go ahead, please.

MR. DYAR: I just want to say, I am all in support of getting more information to make better decisions as managers, and so I've been looking into the confidence interval approach and analyzing that. I do support, just wanted to make a comment, and again not to continue to ring the bell. When you're looking at, and I think Jason you alluded to that when looking at maybe different percentage confidence intervals.

But when looking at the coastwide right now, which has the lowest PSEs of all, you know the confidence interval ranges from 40,000 to 150,000 fish. With a pulse fishery resource that unfortunately lacking independent indices, just want to throw caution

there when starting to look at this. I know once these things get rolling, they kind of get rolling, but just wanted to mention that again. I am for getting more information, but didn't want to seem like once we task folks that then we have to continue down that path.

CHAIR BEAL: I don't see any other hands up. Where we are now is final approval of Addendum II with an implementation date, ideally. Is anyone willing to make a motion to that effect? Shanna.

MS. MADSEN: I don't necessarily want to make it a motion just yet, but I do want to just let the Board know what Virginia's intention is here. We are going to offer an implementation date of the end of February. This is just so that we can go through our regulatory process. We need a little bit longer of a buffer than we used to.

I am also quite frankly down two whole staff members, so we've got a long list of things on our plate, so we're going to just kind of ask for forgiveness if it is okay that we go ahead and implement in February. I'll let folks talk about that if there is some discomfort.

CHAIR BEAL: Emilie, go ahead, please.

MS. FRANKE: Are you talking about implementation for 2025 measures and not necessarily implementation of the Addendum? Because just to sort of clarify, you know if the implementation of the Addendum is effective today immediately, then all of this would be into effect, we would use the new allocations to determine measures for next year. I just want to clarify that you're talking about implementation of 2025 measures.

MS. MADSEN: Apologies, Emilie, I got those two things confused. You are 100 percent right, as always. We are fine with an implementation date of today. Then in the future we would want to have a conversation about when we are implementing our management measures.

These minutes are draft and subject to approval by the Coastal Pelagics Management Board.  
The Board will review the minutes during its next meeting.

CHAIR BEAL: Great, so is anybody ready to make that motion by filling in the blank at the end of the motion? Thank you, Shanna, go ahead, please.

MS. MADSEN: **Move to approve Addendum II to Amendment 1 to the Atlantic Cobia FMB, as modified today, with an implementation date of today.**

CHAIR BEAL: Is there a second? John Clark, thank you. Any comments? I think, Shanna, you've already made your comments in support of the motion. John, do you have anything to add?

MR. CLARK: I do not, thank you.

CHAIR BEAL: Great, thank you. Let's try this. **Is there any opposition to the motion on the board? Seeing no hands in the room, and no hands online, any abstentions? Seeing none; the motion passes unanimously by consent.** All right that's it for the Addendum.

#### **UPDATE FROM THE SOUTH ATLANTIC FISHERY MANAGEMENT COUNCIL MACKEREL PORT MEETINGS**

CHAIR BEAL: The only thing left on the agenda is an update from John Carmichael on the South Atlantic Fishery Management Council Mackerel Port Meetings. John, are you ready to go?

MR. JOHN CARMICHAEL: Yes, let me get this right quick. Since our last update as I had mentioned we had completed the April meetings there in North Carolina and they went quite well, appreciated all the support. Soon after our last meeting we rolled out webinars in New England. There weren't a lot of attendees, which is not surprising, given the fishery is really just getting started up there in some ways.

But those that did attend gave a lot of good insight, and heard a lot about the species and I think made good connections up there to let people know about this fishery and how it's managed really, which is so important. In June there was a meeting

held with the Mid-Atlantic Fishery Management Council meeting.

(Whereupon the meeting adjourned at 3:32 p.m. on Wednesday, August 7, 2024)

Only one member of the public was there, but there was a lot of input from the Mid-Atlantic Council members who were in attendance. and got a lot of great information there as well. Things have been a little tough since then, we had meetings planned in July here recently, and towns in Georgia, ran into issues with another meeting that was planned in Pooler, because of air condition problems with the venue, and also had issue with Murrel's Inlet in South Carolina dealing with Tropical Storm Debbie here this week.

Staff is working on rescheduling the meetings for South Carolina. Upcoming in the end of September on the 30th, working on meetings in Florida, finalizing the locations now, but there is definitely a lot of interest down there, which is not surprising, and we appreciate the ongoing help with FWC to get that going.

Then Mid-Atlantic Council region scheduled for the week of November 18, and our staff will be reaching out to the Commission to get something set up for that. Good thing is, we're getting a lot of positive feedback, even when there is not a lot of attendance we're getting great input from the fishermen, and certainly helping spread awareness of this fishery and potential management changes that are coming. That concludes that report, Mr. Chair.

#### **ADJOURNMENT**

CHAIR BEAL: Great, thank you, John, and thank you and your staff for all the hard work on these Port Hearings, you're really putting a lot of time and effort into getting those comments, so we appreciate that. Any questions for John on the meetings? Seeing none in the room and none online, I think that is everything before the Coastal Pelagics Board today, unless I see any other hands. All right, we stand adjourned.

These minutes are draft and subject to approval by the Coastal Pelagics Management Board.  
The Board will review the minutes during its next meeting.





# Atlantic States Marine Fisheries Commission

1050 N. Highland Street • Suite 200A-N • Arlington, VA 22201  
703.842.0740 • 703.842.0741 (fax) • www.asmfmc.org

---

## MEMORANDUM

**TO:** Coastal Pelagics Management Board

**FROM:** Emilie Franke, FMP Coordinator

**DATE:** October 9, 2024

**SUBJECT:** Timeline for Selecting and Implementing New Regional Recreational Measures for Atlantic Cobia

Addendum II to Amendment 1 of the Atlantic Cobia Fishery Management Plan (FMP) implements a new regional allocation framework which allocates the total 2024-2026 recreational harvest quota of 76,908 fish to two regions: Northern Region (RI-VA) and Southern Region (NC-GA). Per the harvest evaluation for each region against its regional harvest target, the Southern Region can maintain status quo measures but the Northern Region must implement recreational measures in 2025 to reduce harvest by 15.9%. For the new measures, all States in the Northern Region must have the same size and vessel limits, but seasons may vary by state. Refer to the enclosed Memorandum 24-78 from the Atlantic Cobia Technical Committee (TC) for details on management options to meet the reduction.

In response to questions from Coastal Pelagics Board (Board) members about the timeline for selecting the new Northern Region management measures, Commission Staff identified some possible timelines described below. This is not an exhaustive list; the Board may identify other timelines to consider.

**The timeline for selecting the new Northern Region recreational measures and the required implementation date is a Board decision, and should be discussed during Board deliberations at the 2024 Annual Meeting.**

### ***Possible Timelines for Selecting Measures***

- **Possible Timeline 1:** Board selects Northern Region measures at the 2024 Annual Meeting. States in the Northern Region are required to submit implementation plans by a specified date for full Board consideration via email vote.
- **Possible Timeline 2:** Board approves the range of options developed by the TC at the 2024 Annual Meeting. States in the Northern Region take time following the meeting to consider options. If States in the Northern region can come to consensus on which measures to implement, States will submit implementation plans by a specified date for full Board consideration via email vote.

M24-77

- Possible Timeline 3: Board approves the range of options developed by the TC at the 2024 Annual Meeting. States in the Northern Region take time following the meeting to consider options. If States in the Northern Region cannot come to consensus on which measures to implement, a full Board webinar will be scheduled to vote on which measures to implement for the Northern Region. Then, States will submit implementation plans by a specified date for full Board consideration via email vote.



# Atlantic States Marine Fisheries Commission

1050 N. Highland Street • Suite 200A-N • Arlington, VA 22201  
703.842.0740 • 703.842.0741 (fax) • www.asmfmc.org

---

## MEMORANDUM

**TO:** Coastal Pelagics Management Board

**FROM:** Cobia Technical Committee

**DATE:** October 9, 2024

**SUBJECT:** Cobia Recreational Measures for the Northern Region

The Cobia Technical Committee (TC) met via webinar on September 13 and September 25, 2024 to discuss methods for calculating recreational management measures for the Northern Region to meet its harvest target. This memorandum outlines those methods and resulting management options for the Northern Region for implementation in 2025.

**TC Members in Attendance:** Angela Giuliano (Chair, MD), Nichole Ares (RI), Zach Schuller (NY), Jamie Darrow (NJ), Brooke Lowman (VA), Melinda Lambert (NC), Justin Yost (SC), Chris Kalinowsky (GA), Michael Larkin (NOAA)

**ASMFC Staff:** Emilie Franke

**Others in Attendance:** Chris Batsavage (NC, Board Proxy), Alan Bianchi (NC), CJ Schlick (SC), Jesse Hornstein (NY), Shanna Madsen (VA), Will Poston

### ***Regional Allocations and 2021-2023 Harvest Evaluation***

Addendum II to Amendment 1 of the Atlantic Cobia Fishery Management Plan (FMP) implements a new regional allocation framework which allocates the total 2024-2026 recreational harvest quota of 76,908 fish to two regions: Northern Region (RI-VA) and Southern Region (NC-GA). With implementation of new regional harvest targets, each region's average harvest from 2021-2023 was compared to its harvest target to determine if management changes are needed for 2025. Addendum II specifies using a rolling average of up to five years of harvest estimates under the same management measures to determine each region's average harvest. Since management measures were changed in some states in 2021, this evaluation only includes harvest estimates from 2021 through 2023.

Each region's harvest target, 2021-2023 average harvest, and resulting management implication is outlined in Table 1. Since the Northern Region average harvest is above its target, management changes are needed to reduce harvest to the target (15.9%). Since the Southern Region average harvest is below its target, states in that region maintain status quo measures. Addendum II does not allow regions to consider liberalizing measures before completion of the ongoing stock assessment SEDAR 95.

M24-78

Table 1. Regional recreational harvest targets, 2021-2023 average harvest, and required management change per Addendum II.

Region	Recreational Harvest Target	2021-2023 Average Recreational Harvest	Difference from Target	Management Change
Northern Region RI-VA	52,825 fish	62,832 fish	10,007 fish over target	15.9% reduction
Southern Region NC-GA	24,083 fish	23,474 fish	609 fish under target	Status Quo

**FMP Requirements for Regional Management Measures**

As the Northern Region implements the 15.9% reduction for 2025 measures, the current state-by-state measures will change to a set of regional measures. All states in a region must have the same size and vessel limits, but seasons may vary by state. The regional minimum size limit cannot be below 40” total length (36” fork length) as required by the FMP. Current recreational management measures for the Northern Region states are listed in Table 2 for reference. The rest of this report will refer to size limits in total length (TL) since states in the Northern Region implement regulations using TL.

Table 2. 2024 Recreational Management Measures for States in the Northern Region.

	2024 Size Limit	2024 Vessel Limit	2024 Season
RI, NY, NJ, DE	37” TL	1 fish	All Year
MD, PRFC, VA	40” TL (Virginia allows only 1 fish >50” per vessel)	2 fish	June 15 – September 15

**Methods for New Management Measure Analysis**

To achieve the required 15.9% reduction, managers could consider changing the size limit, vessel limit, season, or changing multiple measures simultaneously. The TC agreed on methods to address each type of management measure and potential combinations. The TC used MRIP data pooled across 2021, 2022, and 2023 for all analyses. Potomac River Fisheries Commission harvest is included as part of Maryland and Virginia’s harvest estimates.

Size Limit

First, the TC recognized the initial requirement for *de minimis* states that currently have a 37” minimum size limit (RI, NY, NJ, DE) to increase their minimum size to 40” per the FMP requirements. There is very little MRIP data for these four states given the limited, pulse nature of cobia in their state waters. Further, of the very few length samples available for these four states, none were <40”, so any potential reduction associated with RI, DE, NY, and NJ moving to a higher size limit cannot be quantified.

Assuming all states in the region would begin at a 40” minimum size, the TC compiled MRIP length frequencies for Rhode Island through Virginia to explore various size limit options and

associated reductions. The TC considered using only non-imputed (i.e., observed) length data, however, the sample size was much smaller than the sample size for combined non-imputed and imputed length data. The TC decided to include imputed data in the analysis to have a larger sample size. MRIP data were converted from fork length to total length based on cobia length data from the VMRC Sportfish Collection Program. The TC considered different ways to categorize the individual length datapoints into length bins to ensure the length bins matched with how regulations would be written (e.g., a 41" minimum size limit includes fish greater than or equal to 41.0"; a 53" maximum size limit includes fish up to and including 53.0"). The results of both length bin approaches were the same, and the 'floored' length bins (41" bin is 41.0" to 41.99") were ultimately used. For reduction calculations, fish no longer harvested under the new size limit of interest were assumed to be released, and the resulting additional release mortality was accounted for in the analysis. A 5% release mortality rate was used from the previous stock assessment SEDAR 58. Length datapoints under the current legal size of 40" were not counted toward the reduction as that non-compliance harvest is assumed to continue.

### Vessel Limit

If the Northern Region implements a 1-fish vessel limit, there would be a reduction from Maryland, Virginia, and the Potomac River Fisheries Commission decreasing from their current 2-fish vessel limit. MRIP trip-level intercepts for Maryland and Virginia private vessel and charter boat trips were compiled to determine harvest per vessel trip and number of anglers on the vessel. Head boat harvest has been zero in recent years, and the vessel limit does not apply to shore harvest (subject to 1-fish bag limit), so shore harvest was assumed status quo. The TC assumed all trips would still occur under the lower vessel limit, but trips that previously harvested two fish would now harvest one fish and release the other. Those new releases were accounted for in the reduction calculation using the 5% release mortality rate noted previously.

If the Northern Region implements a 2-fish vessel limit, there would be a potential increase in harvest from Rhode Island, New York, New Jersey, and Delaware increasing from their current 1-fish vessel limit. There is not sufficient MRIP intercept data from these four states to calculate the potential increase, so the TC identified an upper and lower bound of potential increase. The upper bound (greatest potential increase) would be if RI-DE harvest doubles with the increased vessel limit, resulting in an increase of the northern region harvest of 2.5%. The lower bound would be if RI-DE harvest stays the same with the increased vessel limit, resulting in a 0% increase. The average increase would be 1.3%. The TC applied the upper bound 2.5% increase and the average 1.3% increase to all option calculations and there was only one option combination that differed between the two scenarios (noted in the option table below).

### Season

The TC calculated estimated harvest by date (month, day) using combined 2021-2023 Maryland and Virginia MRIP data to explore various season date options and associated reductions. This method of using harvest at a daily level has been used for past cobia season analyses due to the short season duration and pulse nature of the fishery (i.e., catch may be much higher per day at the beginning of the season than at the end of the short season and may only occur for part of

a wave). Reductions could only be calculated for Maryland and Virginia season changes because there are not enough MRIP data for Rhode Island, New York, New Jersey, and Delaware to estimate reductions associated with season changes. Any available MRIP data for those states are typically for one year only (e.g., New York's estimated harvest in 2022 was 3,462 fish but was zero in 2021 and 2023). So, any change to season for those four states would not be credited toward the reduction.

Calculations for lengthening the Maryland and Virginia seasons were also calculated. If the vessel limit was reduced to 1 fish, the associated reduction would exceed the required 15.9%. To compensate, Maryland and Virginia could lengthen their season. Since there are no recent data for a season beyond the current June 15 through September 15 season, the TC calculated the daily harvest rate for the current season and assumed that constant daily rate for any additional days added to the season. The TC noted this was the only method available to conduct this analysis and there is a considerable amount of uncertainty, including varying daily catch rates across weekdays vs. weekends/holidays and the potential for cobia to be available earlier or later in the season as compared to previous years as the exact timing of fish arriving to particular state waters changes from year-to-year.

To combine reductions from multiple management changes (e.g., changing the size limit and season), the TC used the following equation  $A + B + (A*B)$ . This equation has been used to calculate cumulative reductions for cobia in the past, as well as for other species.

### ***Options to Achieve the Reduction***

Table 3 outlines the sets of management options that are estimated to achieve the 15.9% reduction based on the methods described above. The table is not an exhaustive list of possible options; there are combinations of other slot limits and other seasons the TC could provide. For example, for some size limits the table only includes seasons in 5-day increments (e.g., Sep 1, 2, 3, 4 not listed between August 31 and September 5).

The TC emphasizes there are many sources of uncertainty and management considerations, including:

- Analysis assumes fish availability, size frequencies, and angler effort are the same in future years as was observed in 2021-2023.
- If cobia's range continues to expand, more fish could become available to northern states and harvest could increase despite management measures to reduce harvest.
- Regarding what size fish are available, if some states are seeing primarily larger fish, a maximum slot limit could limit the fish available for harvest.
- The season expansion analysis assumes a constant daily harvest due to lack of recent data outside of the current seasons.
- It is very difficult to measure large cobia due to their size, so the process of measuring a large fish to comply with a maximum size limit or with a much higher minimum size limit could result in injury to the fish and a resulting increase in dead releases. Additionally, the effect of gaffing on release mortality may not be fully captured in the assumed release mortality rate. Note Virginia has prohibited gaffing since 2021.

- Virginia’s current size limit allows only 1 of the 2-fish per vessel to be over 50”. If this provision is implemented for the coast, there is the potential for high grading. If this provision is removed in favor of a slot limit with a 2-fish vessel limit, there could potentially be more harvest of larger fish (e.g., 2 fish harvested up to 53”). However, in 2021-2023 only one-third of the MD-VA trips intercepted by MRIP harvested the full 2-fish vessel limit. Overall, it is difficult to quantify any potential impacts of this particular provision.

Table 3. Management options (not an exhaustive list) estimated to achieve at least a 15.9% reduction in harvest for the Northern Region. Each option includes three components: size limit, vessel limit, and season. This table lists options that were closest (but not below) 15.9%. Each season option includes two possibilities: shortening the beginning of the season or shortening the end of the season. Note: The 2-fish vessel limit options assume the upper bound increase of RI-DE harvest due to increasing their vessel limit (2.5% increase to regional harvest).

Size Limit for RI-VA (TL)	Vessel Limit for RI-VA	Season for MD-VA*	Total Estimated Cumulative Reduction
40” minimum	1-fish	June 8 – September 15, OR June 15 – September 22	-16.6%
40” minimum	2-fish	June 15 – August 25**, OR June 30 – September 15	-16.7% -24.4%
41” minimum	2-fish	June 15 – August 31, OR June 27 – September 15	-17.5% -17.1%
42” minimum	2-fish	June 15 – August 31, OR June 27 – September 15	-20.4% -20.1%
43” minimum	2-fish	June 15 – September 15	-20.5%
40” – 51” slot	2-fish	June 15 – September 15	-16.4%
40” – 52” slot	2-fish	June 15 – August 31, OR June 20 – September 15	-23.4% -17.3%
40” – 54” slot	2-fish	June 15 – August 31 OR June 27 – September 15	-19.3% -18.9%
40” – 55” slot	2-fish	June 15 – August 27, OR June 30 – September 15***	-18.3% -27.4%
41” – 52” slot	2-fish	June 15 – September 15	-19.1%
42” – 54” slot	2-fish	June 15 – September 15	-17.8%

\*Seasons implemented for RI, NY, NJ, DE would not be credited toward reduction due to lack of data for analysis.

\*\*All options in the table, including this end date of August 25 were calculated assuming the upper bound of RI-DE increasing their vessel limit (2.5%). If the average 1.3% increase for RI-DE increasing their vessel limit was applied, this season end date could be August 27 with a cumulative estimated reduction of 16.0%.

\*\*\*All options in the table, including this start date of June 30 were calculated assuming the upper bound of RI-DE increasing their vessel limit (2.5%). If the average 1.3% increase for RI-DE increasing their vessel limit was applied, the season start date would be one day earlier on June 29 with a cumulative estimated reduction of 16.1%.



# Atlantic States Marine Fisheries Commission

1050 N. Highland Street • Suite 200A-N • Arlington, VA 22201  
703.842.0740 • 703.842.0741 (fax) • www.asmfmc.org

---

## MEMORANDUM

**TO:** Coastal Pelagics Management Board

**FROM:** Cobia Technical Committee

**DATE:** October 9, 2024

**SUBJECT:** TC Initial Input on Addendum II Confidence Interval Approach

The Cobia Technical Committee (TC) met via webinar on September 13 and September 25, 2024 to discuss the Addendum II confidence interval approach as tasked by the Board in August 2024. The Board asked for TC discussion on the potential application of the confidence interval approach to the regional allocation framework, and to consider other confidence interval levels in addition to the 95% confidence intervals specified in Addendum II.

**TC Members in Attendance:** Angela Giuliano (Chair, MD), Nichole Ares (RI), Zach Schuller (NY), Jamie Darrow (NJ), Brooke Lowman (VA), Melinda Lambert (NC), Justin Yost (SC), Chris Kalinowsky (GA), Michael Larkin (NOAA)

**ASMFC Staff:** Emilie Franke

**Others in Attendance:** Chris Batsavage (NC, Board Proxy), Alan Bianchi (NC), CJ Schlick (SC), Jesse Hornstein (NY), Shanna Madsen (VA), Will Poston

### ***Rolling Average Approach for Harvest Target Evaluations (Current Approach)***

Recreational landings for each region are evaluated against that region's target as an average of annual landings. The timeframe for this average only includes years with the same recreational management measures (i.e., measures have not changed from year to year). If the same recreational management measures have been in place for at least five years, the timeframe includes the five most recent years under these regulations (a rolling 5-year average). If the same management measures have been in place for less than five years, the timeframe includes all years under the same regulations. If a region's averaged recreational landings exceed its annual recreational harvest target, that region is required to adjust its recreational management measures to reduce harvest, such that future annual landings are expected to achieve the regional recreational harvest target. If a region reports a consistent (i.e., consecutive) under-harvest during an evaluation time period for a minimum of 2 years, the region may present a plan to adjust management measures, if desired, to allow increased harvests that do not exceed the harvest target.

M24-79



### ***Confidence Interval Approach***

Per Addendum II, the Board can decide (via Board vote) to switch from a rolling average approach to a confidence interval approach for harvest target evaluation.

For this approach, when a region's harvest is evaluated against the region's harvest target to determine if a change is needed, the Cobia Technical Committee considers the 95% confidence intervals associated with MRIP harvest point estimates for the evaluation timeframe. If the same recreational management measures have been in place for at least five years, the timeframe will include the most recent five years under these regulations. If the same management measures have been in place for less than five years, the timeframe will include all years under these regulations.

If the regional harvest estimate's lower bound confidence interval is above the harvest target for a majority of the years within the evaluation timeframe, this indicates harvest has been above the target, and the region must adjust its management measures to reduce harvest to achieve the target. If the harvest target falls within the regional harvest estimate's confidence interval for a majority of the years within the evaluation timeframe, status quo measures may be maintained. If the regional harvest estimate's upper bound confidence interval is below the harvest target for a majority of the years within the evaluation timeframe, this indicates harvest has been below the target, and the region may adjust its management measures to liberalize harvest such that the target level of harvest is achieved, but not exceeded. To calculate the reduction or liberalization needed, the average landings over the evaluation time period is used relative to the target.

A majority of years within the evaluation timeframe means three out of five years or two out of three years. In the event of one out of two years or two out of four years, the Technical Committee will make a recommendation for Board consideration of a reduction or maintaining status quo measures.

To address years with particularly large confidence intervals (i.e., high uncertainty), years that have harvest estimates with a PSE greater than 50 are not included in the evaluation. Years that have harvest estimates with PSEs between 30 and 50 are subject to review by the Cobia Technical Committee to recommend whether they are appropriate to include in the evaluation. This aligns with MRIP's guidance to use caution for estimates with a PSE greater than 30, and not support the use of estimates with a PSE greater than 50.

### ***Initial TC Discussion on Confidence Interval Approach***

The TC discussed the potential application of the confidence interval approach to the regional framework, and reviewed what the CI approach would have looked like if applied to the current regional harvest target evaluation of 2021-2023 and the previous evaluation of 2017-2019 (assuming regional targets instead of state targets) (Table 1). The TC also reviewed the approach using different confidence intervals other than the specified 95%. The TC considered 90%, 85%, 80%, and 50% for range (Figure 1). Based on this information, the TC discussed observations and initial input for the Board. The TC noted the 95% confidence intervals are large, owing to the uncertainties in cobia removals data. Use of the 95% CI approach would likely result in less frequent management changes (i.e., more status quo determinations).

Although the current rolling average approach does not account for the uncertainties in the data, it allows the Board to respond more quickly to year-to-year changes in harvest. For example, applying the 95% confidence intervals to the current evaluation of 2021-2023 for the northern region would result in a management outcome of status quo while the rolling average approach indicates a reduction is required. Of the confidence intervals reviewed, a reduction was only required for the northern region using the 50% confidence interval<sup>1</sup>.

The TC also noted that Board consideration of management goals for harvest evaluations and how responsive to be could depend on other factors like the frequency of stock assessments. For example, if harvests have been on average above the harvest target and the time between stock assessments is long, the Board may want to be more responsive to year-to-year harvest changes given the infrequent updates on stock status.

Finally, the TC noted that this approach would require numerous TC decisions throughout the process since most years have a PSE between 30-50 (Table 2). For each year with a PSE between 30-50, the TC would evaluate whether to include that year in the analysis.

**The TC notes that more time to consider this approach would be beneficial, including discussion by the Board of how the rolling average and confidence interval approaches would align with their management goals.**

---

<sup>1</sup> If the Board wants to consider a confidence interval different from 95%, that change would need to be made through the next addendum/amendment to the FMP.

Table 1. Outcome of applying the rolling average approach and the confidence interval approach to evaluation of 2021-2023 regional harvest against regional targets, and evaluation of 2017-2019 regional harvest against hypothetical regional targets. Note: The confidence interval outcomes include all evaluation years in the analysis; however, some years have PSEs from 30-50 which could be eliminated at TC discretion.

	<b>2021-2023 Northern Region</b>	<b>2021-2023 Southern Region</b>	<b>2017-2019 Northern Region*</b>	<b>2017-2019 Southern Region*</b>
<b>Rolling Average</b>	Reduction	Status Quo	Reduction	Liberalization
<b>95% CI</b>	Status Quo	Status Quo	Status Quo	Status Quo
<b>90% CI</b>	Status Quo	Status Quo	Reduction	Liberalization
<b>85% CI</b>	Status Quo	Status Quo	Reduction	Liberalization
<b>80% CI</b>	Status Quo	Status Quo	Reduction	Liberalization
<b>50% CI</b>	Reduction	Status Quo	Reduction	Liberalization

\*The 2017-2019 evaluation took place during the previous state-by-state framework. For this exercise, the state harvest and state targets in 2017-2019 were combined into regions.

Table 2. PSE for regional recreational harvest estimates. Yellow indicates a PSE from 30-50. Source: MRIP.

<b>Year</b>	<b>Northern Region RI-VA</b>	<b>Southern Region NC-GA</b>
2014	42.5	30.1
2015	49.3	22.6
2016	18.8	38.6
2017	42.3	46.1
2018	35.2	27.7
2019	22.6	33.8
2020	24.4	27.1
2021	21.2	23.6
2022	23.7	32.7
2023	34.0	42.6

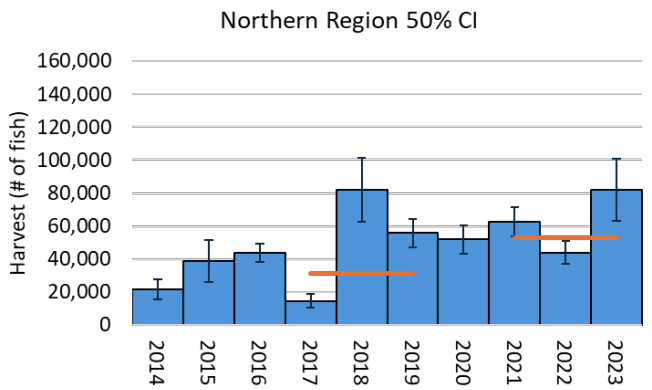
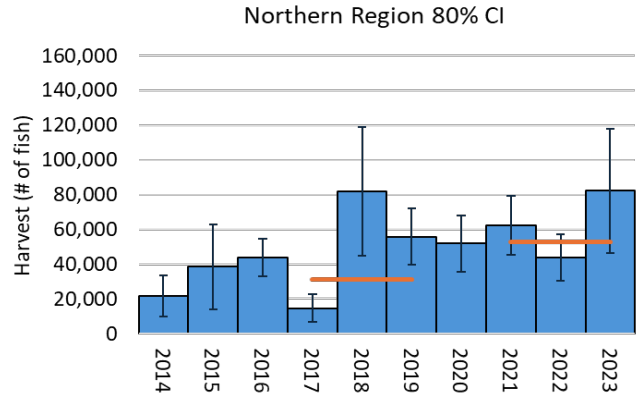
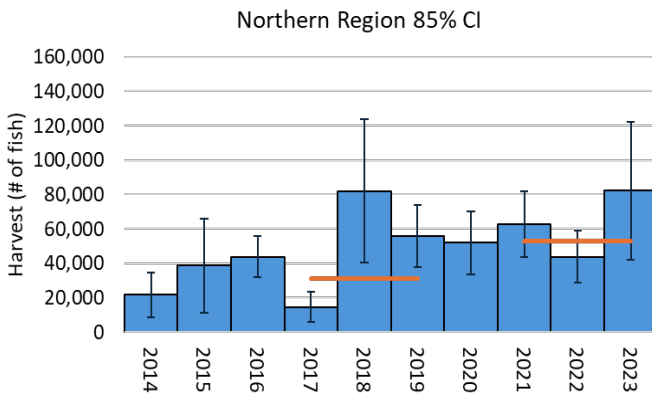
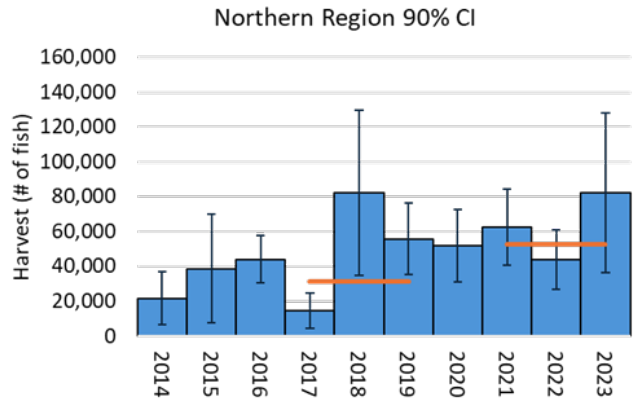
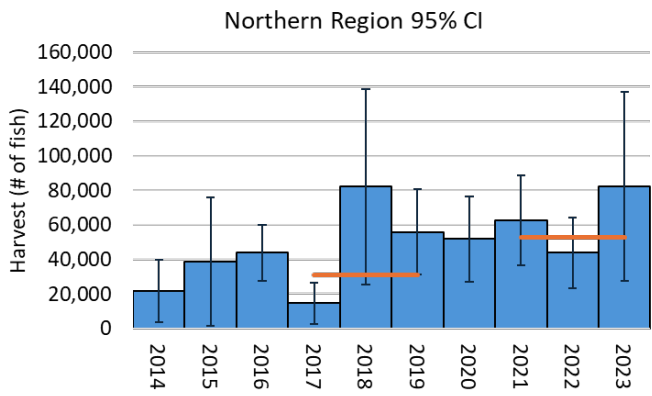


Figure 1. Northern region harvest with 95, 90, 85, 80, and 50 percent confidence intervals and regional harvest targets for the evaluation years considered.

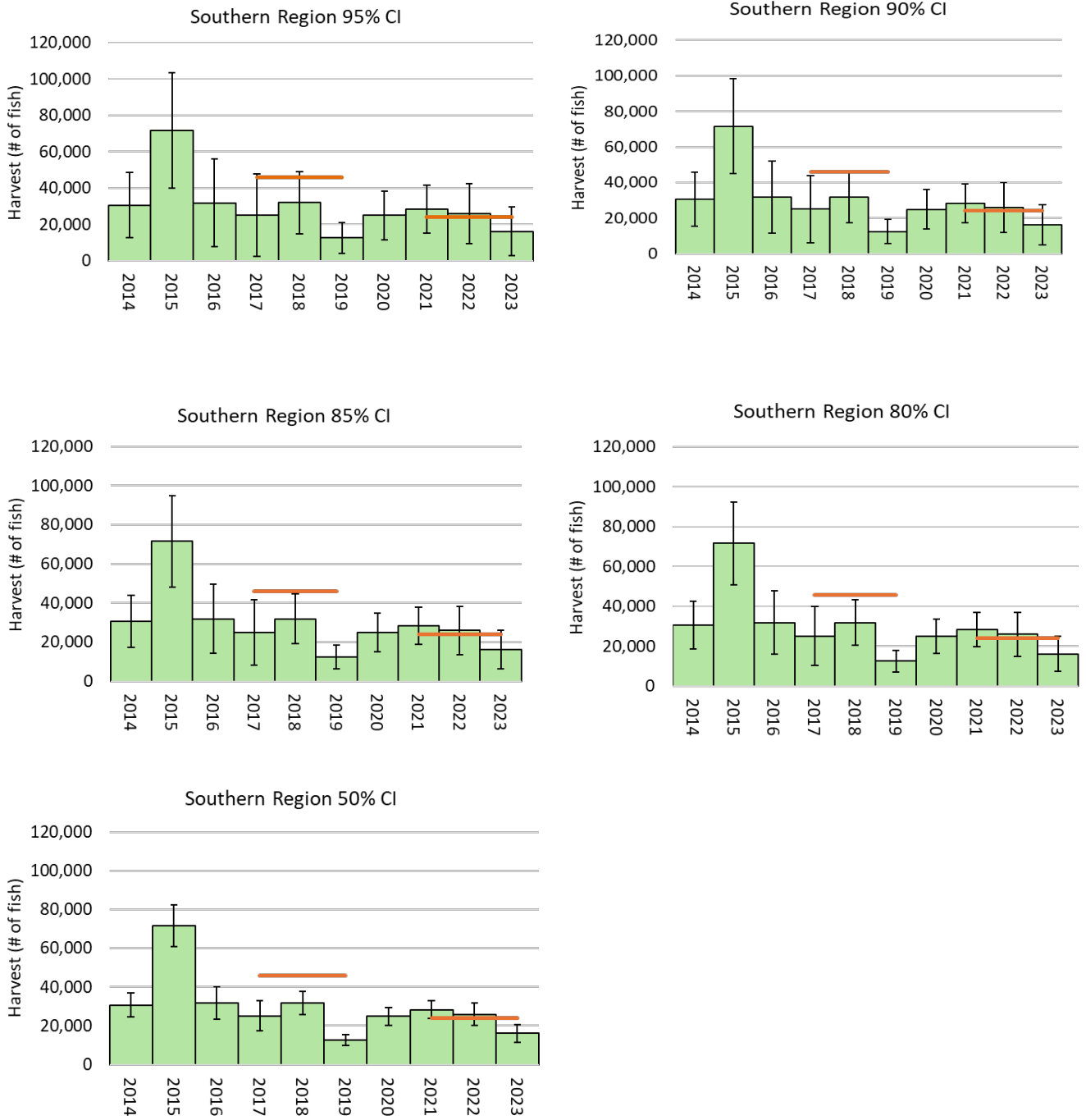


Figure 2. Southern region harvest with 95, 90, 85, 80, and 50 percent confidence intervals and regional harvest targets for the evaluation years considered.

# Atlantic States Marine Fisheries Commission

## Atlantic Menhaden Management Board

October 22, 2024

2:45 – 4:15 p.m.

### Draft Agenda

The times listed are approximate; the order in which these items will be taken is subject to change; other items may be added as necessary.

1. Welcome/Call to Order (*J. Clark*) 2:45 p.m.
2. Board Consent 2:45 p.m.
  - Approval of Agenda
  - Approval of Proceedings from August 2024
3. Public Comment 2:50 p.m.
4. Review Update from Work Group on Precautionary Management in Chesapeake Bay (*M. Gary*) 3:00 p.m.
5. Consider Approval of Fishery Management Plan Review and State Compliance for the 2023 Fishing Year (*J. Boyle*) **Action** 3:55 p.m.
6. Progress Update on 2025 Ecological Reference Point Benchmark Stock Assessment (*K. Drew*) 4:05 p.m.
7. Elect Vice-Chair **Action** 4:10 p.m.
8. Other Business/Adjourn 4:15 p.m.

The meeting will be held at The Westin Annapolis (100 Westgate Circle, Annapolis, Maryland; 88.627.8994) and via webinar; click [here](#) for details.

# Atlantic States Marine Fisheries Commission

## MEETING OVERVIEW

### Atlantic Menhaden Management Board

October 22, 2024

2:45 – 4:15 p.m.

Chair: John Clark (DE) Assumed Chairmanship: 5/24	Technical Committee Chair: Caitlin Craig (NY)	Law Enforcement Committee Representative: Matthew Corbin (MD)
Vice Chair: Vacant	Advisory Panel Chair: Meghan Lapp (RI)	Previous Board Meeting: August 6, 2024
Voting Members: ME, NH, MA, RI, CT, NY, NJ, PA, DE, MD, PRFC, VA, NC, SC, GA, FL, NMFS, USFWS (18 votes)		

### 2. Board Consent

- Approval of Agenda
- Approval of Proceedings from August 6, 2024

**3. Public Comment** – At the beginning of the meeting public comment will be taken on items not on the agenda. Individuals that wish to speak at this time should use the webinar raise your hand function and the Board Chair will let you know when to speak. For agenda items that have already gone out for public hearing and/or have had a public comment period that has closed, the Board Chair may determine that additional public comment will not provide additional information. In this circumstance, the Board Chair will not allow additional public comment on an issue. For agenda items that the public has not had a chance to provide input, the Board Chair may allow limited opportunity for comment. The Board Chair has the discretion to limit the number of speakers and/or the length of each comment.

### 4. Review Update from Work Group on Precautionary Management in Chesapeake Bay (3:00 –3:55 p.m.)

#### Background

- In August 2024, in response to concerns about the Chesapeake Bay ecosystem, the Board established a Work Group to evaluate potential actions for additional precautionary management in Chesapeake Bay (**Supplemental Materials**).

#### Presentations

- Review of Work Group Progress Report by M. Gary

### 5. Consider Fishery Management Plan Review and State Compliance for 2023 Fishing Year (3:55-4:05 p.m.) Action

#### Background

- State compliance reports were due August 1, 2024.
- The Plan Review Team reviewed each state reports and compiled the annual FMP Review.
- Pennsylvania, South Carolina, Georgia, and Florida have requested and meet the requirements for *de minimis*.

## **Atlantic States Marine Fisheries Commission**

### **Presentations**

- Overview of Atlantic menhaden FMP Review by J. Boyle (**Briefing Materials**)

### **Board Actions for Consideration**

- Accept 2023 FMP Review and State Compliance Reports
- Approve *de minimis* requests for Pennsylvania, South Carolina, Georgia, and Florida

### **6. Progress Update on 2025 Ecological Reference Point (ERP) Benchmark Stock Assessment (4:05 –4:10 p.m.)**

#### **Background**

- A Methods Workshop is scheduled for November 4-8, 2024, for both the Stock Assessment Subcommittee and ERP Work Group.
- The ERP Benchmark Assessment and the Atlantic Menhaden Single-Species Assessment Update are both scheduled to be completed for the 2025 Annual Meeting.

#### **Presentations**

- Update on the ERP Stock Assessment by K. Drew

### **7. Elect Vice-Chair**

### **8. Other Business/Adjourn**



## Atlantic Menhaden

### Activity level: High

**Committee Overlap Score:** High (SAS, ERP WG overlaps with American eel, striped bass, northern shrimp, Atlantic herring, horseshoe crab, weakfish)

#### Committee Task List

- 2025 Single-species and Ecological Reference Point Stock Assessments
- Annual compliance reports due August 1st

**TC Members:** Caitlin Craig (NY, Chair), Josh Newhard (USFWS), Holly White (NC), Keilin Gamboa-Salazar (SC), Jason McNamee (RI), Eddie Leonard (GA), Jeff Brust (NJ), Matt Cieri (ME), Ingrid Braun-Ricks (PRFC), Micah Dean (MA), Kurt Gottschall (CT), Shanna Madsen (VMRC), Chris Swanson (FL), Ray Mroch (NMFS), Sydney Alhale (NMFS), Amy Schueller (NMFS), Alexei Sharov (MD), Garry Glanden (DE), Heather Walsh (USGS), Kristen Anstead (ASMFC), James Boyle (ASMFC)

**SAS Members:** Amy Schueller (NMFS, SAS Chair), Caitlin Craig (NY, TC Chair), Brooke Lowman (VA), Matt Cieri (ME), Chris Swanson (FL), Sydney Alhale (NMFS), Jason McNamee (RI), Alexei Sharov (MD), Jeff Brust (NJ), Katie Drew (ASMFC), Kristen Anstead (ASMFC), James Boyle (ASMFC)

**ERP WG Members:** Matt Cieri (ME, ERP Chair), Jason Boucher (NOAA), Michael Celestino (NJ), David Chagaris (FL), Micah Dean (MA), Rob Latour (VIMS), Jason McNamee (RI), Amy Schueller (NMFS), Alexei Sharov (MD), Howard Townsend (NFMS), Jim Uphoff (MD), Shanna Madsen (VMRC), Kristen Anstead (ASMFC), Katie Drew (ASMFC)

**DRAFT PROCEEDINGS OF THE  
ATLANTIC STATES MARINE FISHERIES COMMISSION  
ATLANTIC MENHADEN MANAGEMENT BOARD**

**The Westin Crystal City  
Arlington, Virginia  
Hybrid Meeting**

**August 6, 2024**

These minutes are draft and subject to approval by the Atlantic Menhaden Management Board.  
The Board will review the minutes during its next meeting.

**TABLE OF CONTENTS**

Call to Order, Chair John Clark .....1

Board Consent .....1

Approval of Agenda .....1

Approval of Proceedings from April 30, 2024 .....1

Public Comment .....1

Review Report from US Geological Survey on Osprey Data in Chesapeake Bay.....2

Progress Update on 2025 Ecological Reference Point Benchmark Stock Assessment .....10

Discuss Possible Chesapeake Bay Management .....10

Other Business.....19

Adjourn.....19

## INDEX OF MOTIONS

1. **Approval of agenda** by consent (Page 1).
2. **Approval of Proceedings** of April 30, 2024 by consent (Page 1).
3. **Main Motion**  
**Motion to initiate an Addendum to the Atlantic Menhaden Interstate Fishery Management Plan to consider Chesapeake Bay-specific management options for the menhaden purse seine vessels larger than 300 gross tons in order to support the need of piscivorous birds and fish during critical points of their life cycle (e.g. osprey fledge and molt). The document should include options for seasonal closures of Chesapeake Bay Waters (inside the Colregs Line). The document should not consider changes to the Bay Cap of 51,000 MT. The document should also contain options to reevaluate seasonal closures within the Bay after 2, 3 or 4 years. The Plan Development Team should consult with outside experts as necessary to identify spatiotemporal patterns of predatory demand for menhaden** (Page 10). Motion by Lynn Fegley; second by Robert LaFrance. Motion to postpone (Page 16).

### **Motion to Postpone**

**Motion to postpone until the October meeting** (Page 16). Motion by Pat Geer; second by Robert LaFrance.

### **Motion to Amend**

**Motion to amend to postpone indefinitely** (Page 16). Motion by Pat Geer; second by Eric Reid. Motion fails due to lack of a majority (9 in favor, 9 opposed) (Page 17).

### **Motion to Postpone**

**Motion to postpone until the October meeting** (Page 16). Motion by Pat Geer; second by Marty Gary. Motion fails (6 in favor, 12 opposed) (Page 17).

### **Main Motion**

**Motion to initiate an Addendum to the Atlantic Menhaden Interstate Fishery Management Plan to consider Chesapeake Bay-specific management options for the menhaden purse seine vessels larger than 300 gross tons in order to support the need of piscivorous birds and fish during critical points of their life cycle (e.g., osprey fledge and molt). The document should include options for seasonal closures of Chesapeake Bay Waters (inside the Colregs Line). The document should not consider changes to the Bay Cap of 51,000 MT. The document should also contain options to reevaluate seasonal closures within the Bay after 2, 3 or 4 years. The Plan Development Team should consult with outside experts as necessary to identify spatiotemporal patterns of predatory demand for menhaden.** Motion by Lynn Fegley; second by Robert LaFrance. Motion substituted (Page 21).

### **Motion to Substitute**

**Move to substitute to establish a Board workgroup to consider and evaluate options for further precautionary management of Chesapeake Bay menhaden fisheries, including time and area closures, to be protective of piscivorous birds and fish during critical points of their life cycle** (Page 18). Motion by Allison Colden; second by David Borden. Motion passes (17, 0 opposed, 0 abstentions, 1 null) (Page 18).

These minutes are draft and subject to approval by the Atlantic Menhaden Management Board.

The Board will review the minutes during its next meeting.

**Main Motion as Substituted**

**Motion to substitute to establish a Board workgroup to consider and evaluate options for further precautionary management of Chesapeake Bay menhaden fisheries, including time and area closures, to be protective of piscivorous birds and fish during critical points of their life cycle (Page 18). Motion passes by consent (Page 19).**

4. **Move to adjourn** by consent (Page 19).

**ATTENDANCE**

**Board Members**

Megan Ware, ME, proxy for Pat Keliher (AA)	Kris Kuhn, PA, proxy for Tim Schaeffer (AA)
Rep. Allison Hepler, ME (LA)	Loren Lustig, PA (GA)
Cheri Patterson, NH (AA)	John Clark, DE (AA)
Dennis Abbott, NH, proxy for Sen. Watters (LA)	Lynn Fegley, MD (AA)
Doug Grout, NH (GA)	Dr. Allison Colden, MD, proxy for Del. Stein (LA)
Nichola Meserve, MA, proxy for Dan McKiernan (AA)	Russ Dize, MD (GA)
Sarah Ferrara, MA, proxy for Rep. Peake (LA)	Pat Geer, VA, proxy for Jamie Green (AA)
Ray Kane, MA (GA)	James Minor, VA (GA)
Eric Reid, RI, proxy for Sen. Sosnowski (LA)	Chris Batsavage, NC, proxy for K. Rawls (AA)
David Borden, RI (GA)	Chad Thomas, NC, proxy for Rep. Wray (LA)
Matt Gates, CT, proxy for Justin Davis (AA)	Ben Dyar, SC, proxy for Blaik Keppler (AA)
Rep. Joseph Gresko, CT (LA)	Mel Bell, SC, proxy for Sen. Cromer (LA)
Robert LaFrance, CT, proxy for Bill Hyatt, CT (GA)	Malcolm Rhodes, SC (GA)
Marty Gary, NY (AA)	Doug Haymans, GA (AA)
John Mansicalco, NY, proxy for M. Gary (AA)	Spud Woodward, GA (GA)
Jim Gilmore, NY, proxy for Assy. Thiele (LA)	Erika Burgess, FL, proxy for J. McCawley (AA)
Joe Cimino, NJ (AA)	Gary Jennings, FL (AA)
Adam Nowalsky, NJ, proxy for Sen. Gopal (LA)	Ron Owens, PRFC
Jeff Kaelin, NJ (GA)	Max Appelman, NOAA
	Rick Jacobson, USFWS

**(AA = Administrative Appointee; GA = Governor Appointee; LA = Legislative Appointee)**

**Staff**

Bob Beal	Caitlin Starks	Katie Drew
Toni Kerns	Jeff Kipp	Jainita Patel
Tina Berger	Tracy Bauer	Chelsea Tuohy
Madeline Musante	James Boyle	

These minutes are draft and subject to approval by the Atlantic Menhaden Management Board.  
The Board will review the minutes during its next meeting.

The Atlantic Menhaden Management Board of the Atlantic States Marine Fisheries Commission convened in the Jefferson Ballroom of the Westin Crystal City Hotel, Arlington, Virginia, via hybrid meeting, in-person, and webinar; Tuesday, August 6, 2024, and was called to order at 10:00 a.m. by Chair John Clark.

### **CALL TO ORDER**

CHAIR JOHN CLARK: Good morning, this meeting of the Atlantic Menhaden Management Board is now in session. I am Delaware Administrative Commissioner, John Clark, I'll be chairing this meeting. I am joined here up front from ASMFC by Plan Coordinator, James Boyle, Katie Drew, our Stock Assessment Scientist, and we have guests from the USGS, Dave Ziolkowski and Barnett Rattner, who will be giving a presentation later. We have a very full agenda and not a lot of time, so we will get right down to it.

### **APPROVAL OF AGENDA**

CHAIR CLARK: The consent items, are there any changes to the agenda? Seeing none; the agenda is approved.

### **APPROVAL OF PROCEEDINGS**

CHAIR CLARK: Are there any corrections to the proceedings from the April, 2024 meeting? Seeing none; the proceedings are approved.

### **PUBLIC COMMENT**

CHAIR CLARK: Now we move on to public comment for items that are not on the agenda, and a reminder that both the osprey issue and the Chesapeake management issue are on the agenda. Do we have comments for items not on the agenda? I see one hand here, is that Mr. Zalesak, and this is for an item not on the agenda, Phil.

MR. PHIL ZALESK: Just before I get started here, is John Clark the Chairman of this Committee? All right, Mr. Clark, my name is Phil Zalesak, I'm a spokesman for the Save Our

Menhaden Coalition. The Coalition is demanding an end to localized depletion of Atlantic Menhaden in the Chesapeake Bay and its entrance.

Simply capping the reduction harvest in the Chesapeake Bay to an unscientific quota, and ignoring the entrance to the Bay, is irrational, ineffective and violates common sense. As a U.S. citizen with family in both Maryland and Virginia, I am proposing a solution, which has proven to be effective in eliminating localized depletion of Atlantic menhaden.

I am requesting that you and members of the Delaware delegation put forth a motion to end purse seine fishing in Virginia waters, just as your legislature did in Delaware in 1984. I am also requesting that the motion be seconded by New York delegation. This delegate, his legislature took the same action in 2019.

Since 2019, striped bass recreational harvest in New York has increased by 50 percent from 7 million to 10.5 million. Since 2019, the New York for-hire recreational business has increased, and whales, predator fish, birds have returned to New York waters in abundance. This has been documented in a two-minute video produced by Tim Reagan, a fishing guide and professional videographer. This action is supported by the latest science as documented in the ERP assessment of 2019, is supported by the latest empirical data provided by NOAA.

It will not impact Virginia quota, will not impact Omega Protein's reduction harvest quota by one fish, will end bycatch of the port recreational fishing in Virginia waters, and will end fish spills in Virginia beaches. The current situation is an ecological and economic disaster for both Maryland and Virginia.

According to the Maryland Department of Natural Resources, the striped bass juvenile young of year index has decreased for long term value of 11 to 1. According to NOAA, since 2016 the striped bass recreational harvest in Maryland/Virginia has decreased by 72 percent, from 11.9 million pounds to 3.4 million pounds. According to the Southwest

These minutes are draft and subject to approval by the Atlantic Menhaden Management Board.  
The Board will review the minutes during its next meeting.

Associates Study of 2016, Maryland/Virginia striped bass recreational GDP was over 900 million dollars, and responsible for over 11,000 jobs.

What is the economic loss in GDP and employment of a 72 percent reduction in striped bass recreational harvest in Maryland/Virginia waters, 500 million dollars, 5,000 jobs? It is time to take action. End purse seine fishing in Virginia waters now. That is exactly what Delaware and New York did, nothing more, nothing less, and it worked. Mr. Chairman, be a leader and save the Bay. You can do it. Thank you.

CHAIR CLARK: Thank you, Mr. Zalesak. That concludes our public comments.

**REVIEW A REPORT FROM THE U.S.  
GEOLOGICAL SURVEY ON OSPREY DATA IN  
CHESAPEAKE BAY**

CHAIR CLARK: We will now move on to Item Number 4, which is Review a Report from the U.S. Geological Survey on Osprey Data in Chesapeake Bay, and we have to present, Dave Ziolkowski and Barnett Rattner from USGS.

MR. DAVID ZIOLKOWSKI: It is our pleasure to be here today. Barnett and I will be trading off as we present slides to you here. It is not difficult for me, but I am going to follow some notes to keep myself on schedule here, because we have a lot of information to cover in a very short period of time.

As Mr. Clark said, we're from the U.S. Geological survey, which is a bureau within the Department of Interior. We're often called the science arm of the department. That is just a bit of a misnomer, because some of our sister bureaus like Fish and Wildlife Service also have science capabilities.

But what makes USGS unique is that we're a non-management, non-regulatory agency that is solely dedicated to providing objective and

impartial science to resource managers like yourselves and the public. Barnett and I work at the Eastern Ecological Science Center, specifically at the Laurel Maryland Campus, but we have two other campuses as well, and those are in Kearneysville, West Virginia and Turners Fall, Massachusetts.

As you can see from the green on the map here, we have staff located through many states. Our Center has broad and diverse science capabilities, which you can see listed on the slide here, and we're recognized the world over as leaders in fish, wildlife and associated ecosystem science. But among the work that we do, we're probably most prominently known for our migratory bird science. We house two of the world's largest wildlife surveillance program, those being the North American Breeding Bird Survey and the Bird Banding Lab.

We also have a great many long term bird studies, including a collaborative study working on osprey in the Chesapeake Bay Region for over 50 years. Most of you are familiar with ospreys, you've probably seen them before. They are a large day hunting raptor that is found on every continent, except for Antarctica.

They are loud, they are conspicuous, they tolerate human activity relatively well, and not surprisingly, they are one of the world's best studied birds of prey. The wingspan is about the same as mine, so pretty big bird there. They weigh just under four pounds. They are a long-lived species; most adults can look forward to living up to ten years.

They are often called the fish hawk, which is a really fitting name, because their diet is almost wholly consisting of fish, and in particular they go for a certain size of fish. Most of them are about a foot long, sometimes a little bit less, and they weigh about as much as a small can of soup, so just under a pound.

Osprey plunge dive for their food, and they take food within the first three feet of the water column, just under the surface there. They can be found in pretty much any aquatic habitat close to wetlands, bays, rivers, lakes, mangroves, just about any

These minutes are draft and subject to approval by the Atlantic Menhaden Management Board.  
The Board will review the minutes during its next meeting.



habitat that has shallow water and the right size fish.

As you can see from the map here in North America, they occupy these northern regions and northern populations, start heading south as the waters cool, and then they will travel sometimes thousands of miles down to subtropical and tropical areas. We're very fortunate. Here in the Chesapeake Bay Region, we live in what is called the Osprey Garden oftentimes, just because it is the home of the greatest number of breeding pairs of ospreys in the world.

Here is just a quick look at the phenology of these birds in our area. Birds start arriving in the Chesapeake Bay around St. Patrick's Day each year, and many of them have traveled thousands of miles, excuse me, thousands of miles from their wintering areas, it probably feels like thousands of years, thousands of miles from their wintering areas in the Caribbean and Northeastern South America.

They've expended a lot of energy so their first order of business is to start eating, to get their bodies up to breeding condition, and then they start doing courtship activities, and they start nest building. Their nests are these enormous, magnificent structures built from sticks. In historical times, those were then erected in natural structures like trees, but now in modern times they are using channel markers, cell phone towers, utility poles, artificial net platforms, net platforms, and you name it.

By late April, most females begin laying up to four eggs. They are speckled brown, and they are about the size of a large chicken egg. Females do most of the incubation, and unlike songbirds, they start incubating once they've laid the first egg. This gives an advantage to the first chick, which Barnett will talk a little bit about in a few minutes. Then come June, the eggs are hatching and the parents stay close to the nest for about a month, helping the chicks

thermoregulate, and protecting them from predation.

Then by late July, in the Chesapeake Region, the young have grown to just about adult size, and they start exercising their flight muscles in preparation for fledging, and fledging is when a chick takes a voluntary movement off the nest to begin its life outside of the nest. For weeks after they fledge, they hang out with parents and they perfect their hunting techniques, and they learn how to acquire food. Then they start departing the Bay in September and start heading south again for their multi-thousand-mile journey to the south.

Osprey, being a very long-lived species and on the top of the food chain, they are very susceptible to the body of accumulation of contaminants, and in North America in the 1950s and '60s, osprey populations started declining rapidly, due to the effects of organochlorine pesticides like DDT.

It is estimated that the Chesapeake Bay probably lost about half or more of its population at that time. Partly in response, the North American Breeding Bird Survey was formed in 1966, to start measuring bird populations across the continent at that time. The BBS is a federal program that is jointly coordinated by the U.S. Geological Survey at the Eastern Ecological Center Science Center, in an environment it also partnered with Environment Canada.

The BBS provides the definitive record of large-scale long-term bird population change since 1966. It uses a statistically rigorous scientifically credible bird survey methodology that samples along predetermined roadside routes each year at the height of the breeding season. What I'm going to do in this slide is I'm going to cover a lot of information, but I'm going to walk you through it.

I'm going to review some of the results of the North American Breeding Bird Survey. Here you can see population growth is on the left-hand side, and it's increasing to the right. Between 1966 and 2022, the eastern population of osprey improves by about 300 percent. Then in the Atlantic Coast, where you

These minutes are draft and subject to approval by the Atlantic Menhaden Management Board.  
The Board will review the minutes during its next meeting.

can imagine abundance is even higher, the population increased by about 587 percent. Then in the Chesapeake Bay Region it has increased by about 1800 percent since 1966.

Now you can see here that these blue routes are BBS routes, and that this sampling is not entirely thorough in the area. This estimate of 1800 percent should be given a little less confidence than the other ones, just because the BBS methodology is not optimized for sampling very localized areas, such as the Chesapeake Bay.

But it's still informative, and what these numbers bear out is that osprey have made an astounding recovery by all accounts. The numbers are now in excess of historical numbers, and in part that is because they have returned to a world that is very different than the world was before they started declining. There are more suitable nesting structures, the water may be cleaner. This graph here on the Y axis is an index to abundance, so low abundance down low, and high abundance up high, and the time is on the bottom there, shows you what such great increase in population looks like over time, pretty tremendous climb there. But if you look on the right-hand side of this graph, you'll know something is going on in recent years. I'll take a closer look at this period of time; this is 2012 to 2022. In the lower left-hand corner that yellow section there. What you see is you'll see a line marked by zero. Everything to the right of that is population growth, everything to the left of that is population lost in that 11-year interval there.

The top figure there, that negative 8.8 percent is the trend estimate from BBS during that time period, and as I said, it doesn't operate very well at small scales, so you can see the confidence intervals there are pretty wide, and they cross zero, and that is telling us that we don't have enough statistical power to really say that that estimate is different from zero.

However, there is a bird program that collects recreational observations from birders, and that is called eBird. It's run by the Cornell Lab of Ornithology, and they started to produce trends from their pool of recreational birding observations. You can see those trends here, they are from Maryland is the second down, and Virginia is the third down there.

You can see them both estimating a lot here, and the confidence intervals don't cross zero, so suggesting that the population is declining in that time period in the Chesapeake Bay Region. One great thing about eBird is you can actually bear down and look at the count data to see where exactly those counts are changing.

What you see in this figure here is the state of Maryland, Virginia below it. You can see very large circles all around the Chesapeake Bay, very small circles to the left of it. That tells you that there is very high abundance. Larger circles are higher abundance in the Chesapeake region, dark red indicates the greatest amount of change in the count over that time period.

Care must be used when you are interpreting these kinds of results. To understand what I mean, it's helpful to look at osprey trends across the country for perspective. Here I'll point out three things that I hope you take notice of in these graphs. On the left-hand side here for example, California and Washington, opposite coasts.

You can see that there is something going on in the same time period as there is here in Maryland, Virginia and the Chesapeake Bay Region. Another thing to notice here is that in some of these graphs, even during the long-term increase, there are periods where there is short-term decline.

If you were to focus on those areas of short-term decline, not knowing what is coming to the right of it, you might feel like your population is in a full-scale nosedive, when in fact it's just having a perturbation over time. That is something to keep in mind. Then lastly, populations don't grow forever. We know this ecologically, and at some

These minutes are draft and subject to approval by the Atlantic Menhaden Management Board.  
The Board will review the minutes during its next meeting.

point, density dependency factors kick in and resources.

You would have food or territories, nest platforms, et cetera, become limiting and populations tend to level off to what is called the carrying capacity. Sometimes populations overshoot their carrying capacity and then have adjustment period to come back down. But one thing I wanted to point out on the right-hand side here is that when populations plateau off, like Florida, for example here, whose population underwent some growth but has by most suggestions leveled off now since prior to 2002. That leveling period, that plateau, is very uneven, and there are a lot of perturbations that can happen during that time. This information from these large-scale indices can be very informative. But really the gold standard for local population monitoring is to work with local census data, which are trying to completely enumerate a population. That is where Barnett is going to take us.

MR. BARNETT RATTNER: There have been two major surveys of the distribution and abundance of breeding osprey in the Chesapeake. A 1973 aerial survey in association with some intensive ground surveys of nests with ospreys present, indicated that the population was about 1450 pairs in 1973, and this was during really the height of the DDT use era.

In 1995 and '96, a boat survey of tributaries with some aerial survey components was undertaken and revealed that the population had more than doubled, that is the population of breeding pairs, up to almost 3500, and by the year 2020, it was estimated that there were 11,000 nesting pairs of ospreys in the Chesapeake.

Ospreys, as Dave mentioned, are nearly strictly piscivorous. If a fish species is abundant, the right size and catchable, it's eaten. A great deal is known about the energy requirements during osprey nesting, with males foraging daily during

daylight hours for more than three hours, traveling as much as five to ten miles to catch fish and to bring them back to the nest to provide its mate and young in the nest.

Provisioning depends on the number of young in the nest. For ospreys, what is eaten depends on where they are nesting in the Chesapeake. A snapshot of foraging activity can be gleaned from studies conducted in 2006, '7, '11, '12 and 2013. Catfish and gizzard shad in low salinity tributaries and in the upper bay estuarine areas are the principal foods, at least during some of those study years.

It's striped bass and menhaden in the midday, where there was moderate salinity, and it is sea trout and menhaden again as a snapshot in the lower bay in high salinity areas. Data summarized by Watts and Paxton during the recovery from the adverse effects of DDT documented an increasing reproductive rate for ospreys in the Chesapeake.

It is generally accepted that the rate for maintenance of a stable population is about 1.15 young fledged per active nest, an active nest being a nest in which an egg was laid. Prey abundance is a major factor that drives the osprey reproductive rate. When prey is abundant, the size of chicks is general symmetrical as portrayed on the left side of that slide. Chicks hatched but different days, but well into incubation they are all about the same size, because there is plenty of food.

However, when food is limited a dominance hierarchy is established with sibling aggression and actual brood reduction, which is kind of portrayed on the right. That smaller chick compared to its larger siblings. As you likely know, in the lower Chesapeake the osprey reproductive rate has been reported to be well below the threshold to maintain a stable population for a number of years, particularly in the Mobjack Bay area that is viewed as a demographic sync, and this is work that has been conducted by Brian Watts, students and coworkers. It's important to keep in mind that there are many factors and stressors that can affect osprey reproduction. Yes, limited food availability

These minutes are draft and subject to approval by the Atlantic Menhaden Management Board.

The Board will review the minutes during its next meeting.

can have effects on reproduction, as well as depredation, competition, disease events, inexperienced breeders. There can be storms, weather events, and even very hot weather like we've experienced this year that can affect reproduction.

Certainly, environmental contaminants and also water clarity, it's needed actually for the males to catch their prey. We have identified some important information needs and data gaps related to ospreys in the Chesapeake, specifically. The relation between osprey abundance and reproduction with factors like abundance and reproduction of their prey.

Potential shifts in fish community composition and population trends, not only in ospreys, but in other high trophic level feeders, fish eating birds, striped bass, and bluefish. More detailed information on the relation between salinity, osprey diet, brood provisioning and demography is also needed. Perhaps fisheries independent data on prey fish abundance, age and class size structure.

This year we in the USGS are working with collaborators of the U.S. Fish and Wildlife Service, the College of William and Mary, and others to study osprey productivity and craving brought to their nest in the lower Bay and in Patuxent River, Poplar Island and in the Choptank River vicinity. I think we'll stop at this point and Dave, and I will be glad to entertain any questions you might have. Thank you.

CHAIR CLARK: Thank you very much for that very interesting and informative presentation, Dave and Barnett. I'm sure there are a lot of questions, so I've got Dennis Abbott followed by David Borden.

MR. DENNIS ABBOTT: Mr. Ziolkowski and Mr. Rattner, a real informative presentation. I think we today at the Board are being asked to look at this in a manner of similarities between what was a canary in the mine is the osprey in the Bay, tied into a lack of menhaden. If you would

ask to believe that menhaden, lack of menhaden is the cause, and we should be taking action.

I do say that we can see what is going on physically with the osprey, but we can't see what is going on under the water with the help of the menhaden. If we're to use, can we with some assurance use your studies to tie into a lack of menhaden in the Bay at this point in time? I think that is what we're being asked to do. I'll leave it at that for the moment.

MR. RATTNER: Yes, that is a tough question, and in some areas, it may be a lack of menhaden, but as I showed in a couple of the slides, menhaden aren't in the diet in some regions of the Bay, and some of the work we're doing this year, just at a data collection stage, is really looking at what is being brought to the nest by the adult male, and also pulling together information. There may be some issues with menhaden populations in some parts of the Bay, and it could even be some other species that are dependent on menhaden in other parts of the Bay.

CHAIR CLARK: Go ahead, Dennis.

MR. ABBOTT: Yes, thank you. In your presentation you showed us that there was a 299 percent increase in the population of osprey. That seems counter to the fact that there is a lack of menhaden or adequate food supply in the Bay, with 11,000 pairs nesting there. Would they not be seeking other places to live if the food situation was so bad?

MR. ZIOKOWSKI: You know the response of populations to stressors is often density dependent. As the density of osprey increased, the acuity in which they feel stressors on the population as a whole, can change. If you have a very, very low abundance it may be that the stressor is not of a magnitude to cross threshold that amounts to a population loss.

That as the population increases, you reach a point where certain thresholds get crossed, once certain prey items decline. But ecological systems are very complex. It is often difficult to understand to have a one-to-one relationship between population in a region and one particular stressor.

These minutes are draft and subject to approval by the Atlantic Menhaden Management Board.  
The Board will review the minutes during its next meeting.

MR. CLARK: One last comment, Dennis.

MR. ABBOTT: All it is, is a comment. I noted in one of your slides that striped bass take up 48 percent of their diet, so we've really gotten to the problem of where the striped bass are going.

MR. CLARK: Next question is David Borden.

MR. DAVID V. BORDEN: Excellent presentation. I look forward to looking at it in more detail after the meeting, when we get the slides of it. I'm just wondering to what extent USGS has looked at competitor populations and the relationship between competitor populations like, up our way in Rhode Island, black back gulls, bald eagles, there is an interaction between them and ospreys, and to what extent have you modeled the different populations, to see whether or not that could possibly be having an influence on them.

MR. ZIKOWSKI: That is an excellent question, and that is work that has yet to be done. It can certainly be done with the resources and the datasets that we have. There are relationships between many species, and you can bear out the correlations between population trends. Then if you can understand the mechanism of the relationship between them, you can start to get to the heart of that.

But certainly, bald eagles have recovered as well in the Chesapeake Bay Region, very similar to how osprey have, and they compete for nest locations. Great horned owls have also experienced changes in their population, and they prey sometimes on osprey. It would be very interesting to look at the ecological interactions between these species as the populations change.

CHAIR CLARK: Follow up.

MR. BORDEN: Yes, just a personal observation. I have an osprey tower about maybe 90 feet from the house, not mine, somebody else put it

up. It's amazing how often the bald eagles in the area interact with the ospreys and try to get the ospreys to drop herring or menhaden. The same thing goes on with other species like black back gulls. I think it is worthwhile to look at that.

CHAIR CLARK: Next question is from Representative Gresko.

REPRESENTATIVE JOSEPH P. GRESKO: In your presentation you had some graphs indicating the plateauing or increasing in certain other states at the same time, but they didn't go as far north as New York, Connecticut, Rhode Island, Massachusetts and I'm wondering in simple terms if the potential reason for the plateau or decline of osprey in the Chesapeake Area is because they are going north. Because I'm seeing quite a multiple fold increase of osprey, even in the district that I represent, and I see it all over in New England. Could that be a factor, and has it been factored in?

MR. RATTNER: It's interesting you bring that up. There is a lot of data pouring in, in other states besides those around the Chesapeake Bay, and we've heard, at least I have, in the media, some issues in other estuaries up the Atlantic Coast. One thing to keep in mind is when a pair is formed, a male and female, it's a long-term relationship.

They exhibit nest site fidelity, returning to the same nesting location annually to reproduce. But it is certainly possible that the young might end up in a very different location, and they really don't reproduce until they are three, four or five years of age. It's a little bit of an unknown.

CHAIR CLARK: Next question is from Marty Gary.

MR. MARTIN GARY: Thank you, Dave, and Barnett, for your presentation and your good work. There was a slide you went through pretty quickly; I was wondering if you could bring it back up. It had to do with clutch and fledgling success. I guess the question when you get to that is, how are those trends, at least as they present today, relate to maintenance rates, if that is the right question, and I have a follow, Mr. Chair, if we could after that.

These minutes are draft and subject to approval by the Atlantic Menhaden Management Board.  
The Board will review the minutes during its next meeting.

MR. RATTNER: Could you just repeat the last part of that, please?

MR. GARY: Looking at the clutch success and fledgling success, and I'm not sure this is the right term, maintenance rate to maintain the population.

MR. RATTNER: Yes. That number has been around for quite some time, and it has a pretty good scientific basis. It's about 1.15 young fledged per nest. In the data that I showed from this lower bay, if you look at it, and I'm sorry it's small print. The reproductive rate in the middle column you see in the seventies and '85, well over 1.15, it's 1.7, 1.4, then around 2006, 2007 it is 0.08, so that is not a stable population.

Then more recently 2021, it's 0.3, which is very low. What happens then is birds are moving into that area, because it's a sync, essentially to try to fill in. But they are not doing well, and that is continuing on. It may be certainly beyond the lower Bay. We don't know that and have all that information at this point.

MR. GARY: All right, excellent, thank you, Mr. Chair for a quick follow, just an observation. Having grown up in Chesapeake Bay, worked there for a long time. I look at some of those trends in the charts and I flashback to my childhood, when I read Gilbert Klingel's iconic book, *The Bay*, which I'm always amazed, a lot of people have never even heard of. But in that book of vignettes that was captured in the 1940s from Klingel's very detailed observations, he talks about a huge colony in a very rural, undeveloped area near Smith Plain, Virginia, a tremendous osprey colony.

Now flash forward to the present day, the anthropogenic impacts throughout the Chesapeake Bay watershed, where development is everywhere, including that area that you describe near Smith Point. That osprey colony doesn't exist anymore, but upriver at the agency I worked up to through last year in

These minutes are draft and subject to approval by the Atlantic Menhaden Management Board. The Board will review the minutes during its next meeting.

Colonial Beach, Virginia. Ospreys are everywhere throughout highly suburban, honestly urban areas, and they seem to be doing fine up there. It was just an observation. It's interesting how these animals have adapted, and then one last point.

You mentioned catfish in one of the diet slides. It was amazing that in that part of the river where there are lots of blue catfish, they are obviously eating a lot, because they are dropping all over the streets, on people's cars. They are everywhere. I don't know how they catch the blue catfish, but they do that. Anyway, I did want to thank you for your presentation.

MR. RATTNER: I have one comment on one thing you said, and it's important to point out that in recent decades the ospreys have actually moved up the tributaries, where historically they were not. I think that was shown in one of the figures in a map that the volume wants published.

CHAIR CLARK: Thanks Marty, thanks, Barnett. Next question is from Eric Reid.

MR. ERIC REID: Most of my questions have already been asked. Everybody has talked about bald eagles, and I want to remind everybody that the last time we had a discussion about this, Craig Pugh brought up the interaction with bald eagles, which apparently are doing very well in the population.

My only other question would be, in one of your slides when you had a diet composition, you know in one area it was menhaden and striped bass, for 92 percent, but in the lower Bay, which according to your red dots the fish are not doing that well. I think it was 29 percent sea trout, 24 percent menhaden and 12 percent croakers. What is the other 35 percent?

MR. RATTNER: That I can pull out of Brian Watts paper for you. Please recognize that that is a snapshot, one year, and what was observed in a series of nests. There might be different things going on in other areas near there.

CHAIR CLARK: Next question is Roy Miller.

MR. ROY W. MILLER: I would like to ask your opinion, Dave, and Bennet. You said earlier that there was an 1801 percent increase in the breeding bird survey population for the Chesapeake Bay. I guess that was in comparison to the earlier time record. Given that, and let's just assume for a moment that the supply of osprey food in the Bay has remained relatively stable during that period of time. Is it possible that the osprey population has reached carrying capacity, and what you're seeing where there are fluctuations the last few years up and down a little bit, is just random population responses to other factors, other than forage. Is that a possibility or is there in fact in your view a crisis for the osprey population, in terms of its available forage and osprey nesting success. Are we in a crisis mode or is there a crisis mode in one particular portion of the Chesapeake range of the osprey? Where are we in that regard in your view?

MR. ZIOLKOWSKI: You know, I think that is right on the nose. That is the question right there. It depends on the scale that you look at. When you look at the population from the entire United States, or from the Eastern Region or the Atlantic Coast, or Maryland and Virginia or just the Chesapeake Region.

You can draw different conclusions based on what you see from these different datasets. It certainly may be the case that that localized population that is experiencing food depletion is in a very big nose dive, and it depends on what context and what frame of reference you take that in, as to what conclusions you draw from, in terms of whether we're in the red zone or we're okay there.

In terms of whether the population is plateauing off, well, I often tell people, when you're working with these trends at these very large scales, it's not that different than when you are trying to manage your investment portfolio. We all know, buy low and sell high. But most of us are not billionaires. That is because it is easier to tell what the stock market

is doing in retrospect, when you think, I should have bought.

These large datasets like this and these large trends, they can be very difficult to tell in the short time period what the long-term trajectory is going to end up being. You kind of have to just pick the scale that you're going to focus on. Then you know, you look at what is happening in that localized population or large regional population, and you make your decisions based on that as to whether or not that is an acceptable loss or not. Barnett, do you want to add to that?

MR. RATTNER: Yes, and that is really the answer to the question that was asked and Dave handled. Kind of ask yourself, and I hope not to get in hot water. The osprey is not endangered, it's doing very, very well compared to its history, recent history, 50 years. But, in some parts of the Bay it doesn't seem to be doing well. Maybe it's just the osprey, or maybe it's sort of a sentinel or ecosystem indicator that things might not be quite as well for some other species of fish-eating birds, and that is something that needs to be determined.

CHAIR CLARK: This is a fascinating topic, but we do have to move on, so Pat Geer will be the last question. Thanks.

MR. PAT GEER: I'm honored. Thank you for the great presentation. I just want to follow up on what Dave Borden was talking about. In our species competition we've already talked about bald eagles. But Dr. Watts has done a survey in Virginia, for a number of years going back to, I believe, 1993.

This has shown the double crested cormorant population has increased 1416 percent in that 25 years, and brown pelicans have been about 882 percent. Now those are species that are primarily piscivores. They are competing for the same food source as well. As you said, maybe the nests aren't surviving and they're moving out, and these two species are moving in. Is that possible?

MR. RATTNER: Yes, it's possible, certainly.

These minutes are draft and subject to approval by the Atlantic Menhaden Management Board.  
The Board will review the minutes during its next meeting.

CHAIR CLARK: Thank you very much for the great presentation, Dave, and Barnett. If there are other questions, I'm guessing you guys will be around for a little while here.

**PROGRESS UPDATE ON 2025 ECOLOGICAL REFERENCE POINT BENCHMARK STOCK ASSESSMENT**

CHAIR CLARK: Okay, thank you, and now we're going to move on to Agenda Item Number 5, which is a Progress Update on the 2025 Ecological Reference Point Benchmark Stock Assessment. I'll turn that over to Katie Drew.

DR. KATIE DREW: I'll keep this brief so we can stay on track, but the ERP Workgroup is continuing to work on the assessment, and we are working on bringing in this information from USGS on bird trends into the full model. We're going to see if we have enough information to do it at a finer spatial scale. But I think that still remains to be seen, based on data availability.

But that will include both the information on osprey that was presented here, in terms of trends and abundance, as well as information from basically the same data sources on other near-source piscivorous birds, like eagles and cormorants, where we can pull these data together. We're working on that.

The single-species assessment update continues on pace, more or less, and we will be having our next assessment workshop in the first week of November, the week of November 4, where we will be having the SAS meet to discuss the assessment update for the first day of that workshop, and then the ERP Workgroup to meet to conceive the SAS model runs for the rest of the week. We are continuing on pace with that, and I'm happy to take any questions.

CHAIR CLARK: Thank you, Katie, that is an amazing effort there. Are there any questions for Katie about this update? Not seeing any; let's move on to our, oh, excuse me, sorry. Jeff, go right ahead.

MR. JEFF KAELIN: Thank you, Katie. I have been listening in to the discussions, and you had some pretty positive eagle and osprey data, I think that is going to be part of that consideration. Can you comment on that now, or should we wait until a more full update? It was pretty positive, and I thought it was important for this discussion that we just had.

DR. DREW: Yes, it's positive in the sense that we're seeing a lot of the same trends coastwide that we just saw for osprey, which is really just increasing trends in a lot of these nearshore piscivorous birds coastwide. I think the question is, do we have enough additional information on things like diet composition and other vital rates coastwide, or coastwide versus the Chesapeake Bay, in order to fully incorporate them into the assessment models.

But definitely, I think that we will have better data on these species going into these models this time around, definitely for the full model than we did during the last benchmark assessment.

**DISCUSS POSSIBLE CHESAPEAKE BAY MANAGEMENT**

CHAIR CLARK: Okay, that brings us to Agenda Item 6, a little item that is Discuss Possible Chesapeake Bay Management. To get this started, I'm going to turn it over to Lynn Fegley, from Maryland. Go right ahead, Lynn.

MS. LYNN FEGLEY: I really appreciate it, and I also want to thank the Board for listening. I very much want to thank the team from USGS for providing us with a wonderful presentation that puts the birds in context for all of us, so thank you for that. I'm just going to go right ahead. I am going to make a motion, and Mr. Chair, if I get a second, I would like to speak to it.

**My motion is to initiate an Addendum to the Atlantic Menhaden Interstate Fishery Management Plan to consider Chesapeake Bay-specific management options for the menhaden purse seine vessels larger than 300 gross tons in order to support the need of piscivorous birds and**

These minutes are draft and subject to approval by the Atlantic Menhaden Management Board.  
The Board will review the minutes during its next meeting.



**fish during critical points of their life cycle (e.g. osprey fledge and molt). The document should include options for seasonal closures of Chesapeake Bay waters (inside the Colregs Line). The document should not consider changes to the current Bay Cap of 51,000 MT. The document should also contain options to reevaluate seasonal closures within the Bay after 2, 3 or 4 years. The Plan Development Team should feel free to consult with outside experts as necessary to identify spatiotemporal patterns of predatory demand for menhaden.**

CHAIR CLARK: Thank you, Lynn, we have a motion up and we have a second from Rob LaFrance. Now I will go to the maker of the motion for further discussion.

MS. FEGLEY: By this motion, you were asking for the development of options for seasonal closures of the Chesapeake to the largest of the purse seine gears, as a precautionary measure to ensure that animals such as osprey that depend on menhaden during critical points of their life cycle, have as much opportunity as they need to access these fish.

In Maryland, we do not believe that this motion addresses just the Chesapeake issue. If you need an essential estuary provides critical habitat for many of the species that we manage, and lots that we do not, during critical points in their life cycle. In Maryland we are seeing many signs of stress in our Chesapeake. There are no menhaden in Maryland.

The artisanal stational gears that Maryland watermen fish are not capturing bait for our crab fisheries. We are seeing bottlenose dolphins in unprecedented areas, and we are fielding far too many calls to remove dead dolphins from citizen shoreline. While we don't lay all this at the feet of the large purse seine fisheries, we believe it is common sense to alleviate stress where we can control it. As we saw from the presentation we just received,

bird populations have expanded tremendously in the Bay region.

The demand for forage in the Bay has increased, along with their population. Years ago, when a peer review panel from the Center of Independent Experts convened to review Chesapeake work, to examine localized depletion, they said, as the abundance of predators continues to increase, their food requirements will also continue to increase, to the point where they may become food limited. They also said things like, a stable menhaden population will not be able to sustain the increasing predator population, and offered to us that time and area zoning of fisheries would be a logical way to mitigate negative impacts. These experts gave the Commission the path, that at the time we chose not to take. All of this said, this Commission has diligently and carefully managed this resource, according to the best available science on a coastal level. I am personally extremely proud of the work to develop ecosystem reference points that ensure more conservative fishing levels to leave extra fish in the water.

However, I also believe it is hubris to some degree, to think that we understand all of the dynamics at play with menhaden and the animals that depend on them within the Chesapeake. While we can say with confidence that the stock is healthy on a coastal level, we have not been successful in getting the Chesapeake-specific science needed to ensure sustainable fisheries.

We are not asking that the Bay cap be changed, and we are not asking that gears of all sizes leave the Bay, just the very largest, to mitigate the amount of removals. We are also suggesting that any closures be reevaluated in a certain number of years, and this evaluation could be on new science around menhaden in the Chesapeake. To close this up, we feel that this is responsible to start this conversation to look at seasonal closures. I'm just going to stop and leave it there, Mr. Chair. Thank you for listening.

CHAIR CLARK: Thank you, Lynn, and Rob, as the seconder, would you like to make some comments?

These minutes are draft and subject to approval by the Atlantic Menhaden Management Board.  
The Board will review the minutes during its next meeting.

MR. ROB LaFRANCE: Just quickly, a few. I just want to point out that this particular management board, the Menhaden Management Board, has been a leader for system-based management. I think what we're asking here is to use that vision that we've had for this species, and focus that vision on the Chesapeake.

We have information from new science that we know about ospreys and the impact of that, and there is a lot of information that needs to be delved into. But to look at time of year closures to help species that may be in trouble in Chesapeake, given the large amount of output that we've heard from our constituents, I think is very important.

I also would argue that looking at the Chesapeake Bay, and looking at it in sort of precise terms, we're really looking at the ecological efficiency. We're not talking about changing the Bay Cap. What we're talking about is possibly changing where and how we take. I think that is an important element for us to look at, and I think we have some really talented folks in Atlantic States who can really delve into this, and give us some really helpful information.

CHAIR CLARK: I'm guessing there are a lot of people who would like to make comments, so why don't we do this. If you would like to speak in favor of the motion, would you please raise your hand now, so I can write it down? I've got Dennis, Allison, Russel, I'm going around, Jeff.

MR. KAELIN: I'm not raising my hand in support, I'm raising my hand to make a motion, Mr. Chairman.

CHAIR CLARK: Okay, well, why don't we do this. Why don't we take a few comments, and then I'll come back to you on that. Anybody else that wanted to speak in favor of the motion? Go right ahead, Eric.

MR. REID: How many purse seine vessels are over 300 tons in the Bay? How many vessels that actually carry purse seines and fish from a 300 ton or more vessel is there? There are a lot of carriers that are 300 tons, but they get fish from pairs of small boats. I'm not sure what this actually accomplishes, if anything at all, my only question.

CHAIR CLARK: Lynn, or perhaps Virginia, do you have an answer to that question?

MR. GEER: I kind of question that myself, because our licensing for purse seine boats is greater than 70 tons and less than 70 tons, so I'm not sure where this 300 is coming from as well.

CHAIR CLARK: Okay, we've got some confusion on that. Let me get the hand on those that want to speak against the motion, and then we will start going at comments. I've got Joe, Nichola, Pat and Megan. Anyone else? Emerson, okay. I guess we'll take some of these discussions, and then we will go to you, Jeff, for a motion. Let's start, we have Dennis to speak for the motion.

MR. ABBOTT: I do thank Lynn Fegley for bringing this motion forward. I can't thank her enough for doing it. Having sat on this Board since its inception, really, going back over 20 years. How many times have we heard that we should be doing something for the menhaden? I can remember a gentleman named Jim Price from Maryland, he used to come to every meeting, and give us history on what he felt was going on in the Bay with poor health of striped bass, and relating it to menhaden.

I think we should take a look at the previous meeting that we just had, where we saw that Atlantic herring are in, I'll call it serious trouble. It wasn't very long ago that we were harvesting over 100,000 metric tons of herring, and this morning we heard that we can be looking forward to harvesting, what 783 tons or something like that, some low number. How that all happened, I don't know.

But I go back to the canary in the mine situation, that we should be getting ahead of this problem, and we've waited too long. I won't dig into the

These minutes are draft and subject to approval by the Atlantic Menhaden Management Board.  
The Board will review the minutes during its next meeting.

weeds of this motion. But this gets us off the ground and doing something. I think that the people in Virginia and Maryland have been crying to us, crying to us for years for us to do something for the menhaden in the Bay.

I think in whole, we've sat back and done very little, very little for the benefit of menhaden, and for the people in the Chesapeake Bay Region. Therefore, even though I live up in New Hampshire, and don't have a very big oar in this water, by any means. I think that the time has come to do something.

CHAIR CLARK: Against I have Joe Cimino.

MR. JOE CIMINO: I'm certainly not against exploring this, I'm against seeing this motion prior to what Katie talked about, and seeing the ERP come out. What is happening in the Chesapeake Bay isn't happening in a vacuum. Striped bass stopped showing up in North Carolina over a decade ago, and coastal Maryland and southern Virginia stopped seeing coastal migrants of striped bass many years ago.

Six or seven years ago, Maryland started showing 0 harvest in their MRIP estimates. It's not just in the fisheries, the winter, which we'll be talking about later today, the winter tagging survey has been moving farther and farther north to find fish. Climate change is real. You know weakfish didn't disappear from the Chesapeake Bay, they disappeared from Massachusetts to Florida. We're dealing with something that we need to take a holistic approach to.

The idea that 300 gross ton vessels are part of the problem, and then the other end of that is part of the solution, is not something I'm very comfortable with. I do hope that as we move forward, because everything is changing, we are in unprecedented times. We do need to take a look at this. But I think we need to get past the ERP and see what happens, and take a holistic approach to this, you know all the literature

suggests that menhaden overwinter off of North Carolina.

Of course, the Chesapeake Bay would be a very important Ingress to where juvenile menhaden show up. The literature also suggested that some portion was overwintering off of New Jersey. It's very possible that a larger portion of those fish are now overwintering off of New Jersey. That is why we're seeing a year-round fishery for striped bass in New Jersey.

We're seeing the whales year-round in New Jersey, and because of that we wouldn't expect to see the Chesapeake Bay have the importance that it has had in the past. I think all these things are something that needs to be addressed. We need to do our best to stay on top of that, for the management of all of these species. But I think this is really jumping the gun and very pointed at something that may not be a solution in any way.

CHAIR CLARK: Next in favor of the motion I have Allison Coldon.

DR. ALLISON COLDEN: I just want to express my gratitude as well to USGS for being here and presenting that information. When it comes to menhaden management in Chesapeake Bay, I'll just go ahead and acknowledge there are a lot of things that we don't know. But there are a few things that we do know.

First of all, and maybe to Joe's point. We do know that the ERPs that they are currently being developed and worked on, will not address questions in the Chesapeake Bay. Those opportunities are very far off in the future, if they are possible at all. Our attempt thus far to get those studies and those data surveys and other things needed to answer those questions, have not been successful or fruitful.

We know a couple of other things, that we are seeing incredibly fast-paced changes in environmental conditions in the Chesapeake Bay. Our average water temperature has increased. The amount of fish habitat availability has decreased,

These minutes are draft and subject to approval by the Atlantic Menhaden Management Board.  
The Board will review the minutes during its next meeting.

and this recovery of osprey is absolutely tremendous. But what that translates to is a tremendous change in the predatory demands on the Chesapeake Bay's menhaden population. That necessitates a reevaluation of our approach to menhaden management in the Bay. Obviously, being around this table not nearly as long as some others. But this, even for me, is not a new conversation. It is obviously something that the Commission has been grappling with for a while. But the conditions that we're seeing now are new, and they are unprecedented.

Ospreys and other birds are now recovering from those DDT era levels, and increasing in abundance. Our large-scale fisheries have contracted to operating in only one state in the same time that those osprey populations have been increasing. When those menhaden fishing rates were higher historically, they were also more distributed along the coast.

We have not seen this overlap in space or time of high avian predatory demands with concentrated spatial harvest in the history of our management of the fishery thus far. Hopefully, I hope it's to say that the predatory demand will be increasing further in the Bay, as we work to rebuild and recover the striped bass population. Using again, osprey as a canary in the coal mine, or a signatory species for the Chesapeake Bay ecosystem, will only help serve our striped bass rebuilding, as we continue to move forward.

Lastly, I just want to address. We acknowledge the fact that there may be other factors at play here. I just listed a couple of them for you that our organization, DNR and others, are tracking within the Bay. But this Board is responsible for managing the menhaden fishery in the Chesapeake Bay and along the coast. While we can't possibly address all of the issues facing the Chesapeake Bay, I'll take that on in my day job. I don't think the public expects us to. But they do expect us to manage menhaden in the way that we have committed to, and that is to be

precautionary and protective of the ecosystem that relies on menhaden. I believe that this motion will have the opportunity for us to open that important conversation, provide opportunities for the public to weigh in, and provide opportunities to address the ecosystem concerns. I would urge everyone's support and thank you.

CHAIR CLARK: Next opposed, I have Nichola Meserve.

MS. NICHOLA MESERVE: I don't disagree with many of the comments that have been made, by supporters of the motion. What I'm struggling with a little bit is the process and diving immediately into an addendum process. The presentation and discussions have underscored the complexity of the issue here, that this is a significant action.

There have already been questions about the singular focus on purse seine vessels larger than 300 gross tons. I think the PDT could potentially use some additional direction than what's provided in the motion on the range of strategies to consider. I've been thinking about the process that this Board took when it began Addendum II to look at allocation, and the incidental catch provision.

All of that began with a work group, a board work group that discussed the issues and the concerns that developed potential strategies to address these concerns, outline the benefits and the challenges of those strategies. I think that in this instance that would be a better way to move forward at this time, to tackle this item. I am opposing it just on the basis of wanting there to be another step before we initiate a document. Thank you.

CHAIR CLARK: Next up in favor I have Russel Dize.

MR. RUSSEL DIZE: I'm speaking as a life long fisherman, around the Chesapeake Bay we're called watermen, and a pogy fisherman. I have actually worked on a pogy boat and seen what pogy boats catch. I think we're trying to save the osprey, and we're forgetting about the other predator, which is man.

These minutes are draft and subject to approval by the Atlantic Menhaden Management Board.  
The Board will review the minutes during its next meeting.

In Maryland, this year we have no menhaden, none. A friend of mine, Robbie Wilson, who has 3 pound-nets set in the Bay, his highest catch is a half a bushel. One half a bushel, Maryland has no menhaden. What we need to do, what I had planned to do, until Lynn put this motion up, was to ask for a moratorium for two years on pogy fishing in the lower Bay.

This isn't coming from someone who doesn't know it. My brother was a captain of a pogy boat for nearby 40 years. I fished on a pogy boat. I fished in Britain Sound, Mississippi Sound, and the Gulf of Mexico, all the way to Raccoon Point, which is Texas. I know what they can catch and I know what they can do.

But the problem in Maryland is, I want to say the creatures, the predators that have two arms and two legs, because we don't have them and we can't punish the fish for the crab industry. Where do you think the fish are coming from for the crab industry? Maine. They are shipping them down from Maine to furnish bait for the crab industry. Look, we can save the osprey, but I want to save our watermen too. We have plenty of osprey. I love the osprey; I don't want to see anything happen to the osprey.

I want to save our fishermen too. Think about this, because what I had planned to put up here was much more aggressive than this, because we're talking about pogy boats. Let's get down to it, 300-ton boats are pogy boats. There are the boats working out of the factory in Virginia. Think about crossing the Maryland area of the Chesapeake Bay, because we don't get any menhaden if they don't come through Virginia., so think about it. Thank you, Mr. Chairman.

CHAIR CLARK: Thank you, Russel, and opposed now we have Pat Geer.

MR. GEER: A number of factors are affecting osprey; we've already talked about that. You know huge increases in other bird species that are competing with them for food sources. This

motion is basically singling out an industry because of public opinion, in a sense. It doesn't seem appropriate without the necessary science.

You know we're saying, let's go in and try this and see what happens. This motion is leading down a path that the seasonal closure for a fishery, based on public opinion. We need the science first. We need to have that information. You know it is very frustrating for us, and it's embarrassing that we can't get the funding to do this if it is that important. I want to see the science done. I want to see the ERP results first. I want to see what is going on with that before we move forward with anything such as this. The ERP assessment will come out and we'll have information from that. We can look at that and see what happens with that first. But we shouldn't be taking a management action until we have that science in the ERP assessment.

CHAIR CLARK: In the interest of time, I know we have a couple more, Megan Ware and Emerson Hasbrouck that wanted to speak against this motion, but we are running up against it, and I know we have another motion that was wanted to be made by Jeff Kaelin. In the interest of time, I'm just going to turn it over to Jeff right now. My apologies.

MR. KAELIN: I move that this motion be tabled until the Ecosystem Reference Point Peer Review results are available in 2025. That's my motion.

CHAIR CLARK: That would be postpone, Jeff, are you okay with changing the wording.

MR. KAELIN: Postpone uncertain, yes if we're not going to table it.

CHAIR CLARK: Is there a second to that motion? I am not seeing a second, is there a second online? No second, so that motion goes away for lack of a second. That leaves us with the main motion. Pat Geer.

MR. GEER: I'll make a motion to table this.

These minutes are draft and subject to approval by the Atlantic Menhaden Management Board.  
The Board will review the minutes during its next meeting.

CHAIR CLARK: Table would be to consider it in this motion. Would you like to postpone the motion?

MR. GEER: I don't want to postpone it; I want to table it.

CHAIR CLARK: Based on the terminology, table we would still be coming back to it at this meeting.

MR. GEER: At this meeting.

CHAIR CLARK: This meeting, so you want to table it?

MR. GEER: Well, it doesn't have to come forward at this meeting, it has to come forward at the next meeting, according to Roberts Rule.

CHAIR CLARK: Okay, Toni.

MS. TONI KERNS: Pat, tabling is for just within the meeting, postpone you would postpone it to the October meeting.

MR. GEER: Sorry for the clarification on that.

CHAIR CLARK: We're getting a crash course in Roberts Rules of Order here. **Next motion here is to postpone this motion until our October meeting**, we have a second from Marty Gary.

MR. ABBOTT: Point of order.

CHAIR CLARK: Yes, sir.

MR. ABBOTT: Yes, thank you, Mr. Chair. Is this a debatable motion?

CHAIR CLARK: Bob.

EXECUTIVE DIRECTOR ROBERT E. BEAL: The only portion of a motion to postpone that is debatable is the time element, so if somebody wanted to suggest something other than October that could be debated, but the part

about postponing or not postponing is not debatable.

CHAIR CLARK: Thanks, Bob, so I see a hand there from Allison Colden, did you want to change the time?

DR. COLDEN: No, I have an additional motion.

CHAIR CLARK: Okay, based on the rules, do we have to vote on this first? Okay, so this is the motion that must be voted on, so I think we all want a little time to caucus here, so can we have a two-minute caucus? Okay, we've had caucus time. Does anybody need more time here? Please, raise hands if you do. Not seeing any hands, please return to the table. Thank you. Before we take a vote on this, we have a Board member who has asked to amend the motion with the legal part of the amendment, which is to change the time.

MR. GEER: We just had a discussion of tabling versus postponement, and it's different how you define Roberts Rules, but my intent was to postpone this indefinitely.

CHAIR CLARK: This would be to **amend the motion to change the October meeting to postpone indefinitely**. Do we have a second for that motion? We have a point of order coming from Mr. Abbott.

MR. ABBOTT: We have a motion made by Mr. Geer. That motion now belongs to the Board. I don't believe that it can be changed at this point.

CHAIR CLARK: In other words, Pat made the motion that is up on the Board right now. Let me go to Bob here. Boy this is quite a rule of order.

EXECUTIVE DIRECTOR BEAL: Thanks, turning into a parliamentarian by default. An individual on the Board can amend their own motion, so I don't think Mr. Geer is asking for a friendly amendment here. He is asking to make a motion to amend, changing October meeting to indefinitely.

CHAIR CLARK: Thanks, Bob, okay. It is a legal motion; we have a second from Eric Reid. Do we

These minutes are draft and subject to approval by the Atlantic Menhaden Management Board.  
The Board will review the minutes during its next meeting.

need to caucus on this, because now this is a whole different thing. Instead of bringing it back in October we would be motioning to just put this off forever. Does the Board need time to caucus? Yes, another two minutes. Does anybody need more time to caucus? It looks like everybody is back at the Board. I'm not seeing any hands. Before we vote on this, we do have a hand online from James Minor of Virginia.

MS. KEARNS: I think the Chair has just said, as a reminder you're speaking to the time only. James, you're talking but we can't hear you.

MR. THOMAS P. FOTE: Toni, this is Tom Fote, we can hear him online, it's just not getting through to the meeting.

MR. JAMES MINOR: Just leave the sea with the boat. I'm good. As long as you all can hear me. I was having, I think it was some technical difficulties going on, so I'm here.

CHAIR CLARK: Okay, we've had time to caucus, we have a motion to amend on the floor, and let's vote. **All those in favor of the motion to amend the motion to postpone, please raise your hand and hold them up there. Okay, put those hands down, and now for those opposed, please raise your hands.**

MS. KERNS: **Online we have Florida, South Carolina, and Georgia in opposition.**

CHAIR CLARK: **Is it 9 to 9? Okay, I'm sorry, are there any abstentions? Are there any nulls? Not seeing any, okay the motion fails. It's tied 9 to 9, so that means the original motion is now the main motion, and that motion is, move to postpone until the October meeting. All those in favor, please raise your hands. Okay, sorry about that, put your arms down now, I'm sure you're getting tired. All those opposed to the motion, please raise your hand.**

MS. KERNS: **I also have Florida, South Carolina, and Georgia.**

CHAIR CLARK: **Holy moly, so it looks like the main motion just failed there, right? That's what I meant, not the main motion, I meant the postponed motion. Our motions to postpone, in other words, have both been defeated.** Are we going back? Instead, I see, I think we have some other motions that want to be made here. Allison.

DR. COLDEN: Just procedure wise, I want to make sure we're back to the main motion now.

CHAIR CLARK: We are back to the main motion, yes.

DR. COLDEN: You know obviously I was giving my comments earlier, actually I just need to give you the motion first, hold on. **Move to substitute to establish a Board workgroup to consider and evaluate options for further precautionary management of Chesapeake Bay menhaden fisheries, including time and area closures, to be protective of piscivorous birds and fish during critical points of their life cycle.** I did add something to what you had there.

CHAIR CLARK: Thank you, Allison, and we have a second from David Borden. Would you like to speak to the motion, Allison?

DR. COLDEN: Yes, obviously this is something that is critically important to our delegation. I appreciate all of the supportive comments around the table for the main motion, but I do want to just point out that we hear and are responsive to the other members of the Board who have an interest in sitting with this for a little bit longer.

But we also want to make sure that if we were to revisit this later on that we continue to make progress, given all of the concerns that we have seen with the osprey information that was presented, given all the concerns that we hear on a consistent basis from our constituents. I wanted to offer the opportunity to continue that conversation, so that we can have a continued discussion of this at the October annual meeting.

These minutes are draft and subject to approval by the Atlantic Menhaden Management Board.  
The Board will review the minutes during its next meeting.

CHAIR CLARK: David, were there any comments you would like to make?

MR. BORDEN: I don't have much to add, other than the fact that I think this is a more logical way to proceed. We'll get back a product that has been thought through, carefully crafted, and hopefully refined. Thank you.

CHAIR CLARK: Okay, I think we've discussed this issue quite a bit, but we do have one person who has not had a chance to really comment on the motion, that is James Minor, oh and Bob has something to say here.

EXECUTIVE DIRECTOR BEAL: Just briefly, before Mr. Minor has a chance to talk. I just wanted to let everyone know that the Chair is recognizing James Minor, because he is a new Commissioner from Virginia, so he is not a member of the public. I just wanted to let people know that that is his position. He hasn't been able to attend the meeting, but he is a new Commissioner from Virginia.

CHAIR CLARK: Thanks, Bob, and thank you, and welcome to the Board, Mr. Minor, and please, go right ahead.

MR. MINOR: My hand was just raised. I think there is something going on with this internet, so I'm good. I don't have any comment, thank you.

CHAIR CLARK: All right, thank you. Do we need time to caucus? We have a comment from Doug Haymans.

MR. DOUG HAYMANS: I thought I heard the maker of the motion say something about time area closures in the motion that I don't see on the board. Also, I'm curious as to whether there is a time that this workgroup should be reporting back to the Board. Thank you.

CHAIR CLARK: Bob, looking at Allison, I think you meant to have some of that in there. Can

that be added as a friendly at this point, or is this that?

EXECUTIVE DIRECTOR BEAL: If she said it, and Allison, I don't remember, so I apologize. If Allison said it, as she was making the motion and it is just differed from what staff had, it's not even a friendly motion, it's just recording what she said, so we could do that. Then I think in her comments Allison mentioned that the workgroup could make some progress and bring at least a first report back at the annual meeting.

CHAIR CLARK: Okay, could the motion be modified to reflect that?

EXECUTIVE DIRECTOR BEAL: Maybe Allison can provide the language around potential spatial and temporal.

DR. COLDEN: Yes, would you like me to just read it into the record again from the beginning?

EXECUTIVE DIRECTOR BEAL: Please.

DR. COLDEN: **Move to substitute to establish a Board workgroup to consider and evaluate options for further precautionary management of Chesapeake Bay menhaden fisheries, including time and area closures, to be protective of piscivorous birds and fish during critical points of their life cycle.**

CHAIR CLARK: Okay, thank you. At this point we still have the second from Mr. Borden. I think we've discussed this issue quite a bit. Do any of the delegations need time to caucus? I am not seeing that, so in that case, **I'll call out the states. Okay, so want me to just do the roll call? You're going to do the roll call, okay. Toni is going to do a roll call of the states here. Okay, all in favor raise your hands, and Toni will call out the state. All right, go right ahead.**

**MS. KERNS: Massachusetts, Connecticut, New York, New Jersey, Fish and Wildlife Service, NOAA Fisheries, Pennsylvania, North Carolina, Virginia, Potomac River Fisheries Commission, Maryland,**

These minutes are draft and subject to approval by the Atlantic Menhaden Management Board.  
The Board will review the minutes during its next meeting.



**Delaware, Maine, New Hampshire, Florida,  
South Carolina, Georgia.**

**CHAIR CLARK: Okay, was that unanimous?**

**Okay, it was not unanimous, all those  
opposed, please raise your hand.**

**MS. KERNS: None.**

**CHAIR CLARK: Okay, so it was unanimous. Is  
anybody abstaining from this vote? Are there  
any null votes?**

**MS. KERNS: Rhode Island.**

**CHAIR CLARK: Oh, sorry, I'm sorry, Eric. You  
guys are confusing me. Now this motion  
becomes our main motion, correct, and we  
have to take another vote. Do we need  
another roll call, or is this just going to be,  
okay, is there any opposition to the motion?  
I'm looking at you, Rhode Island.**

**Okay, so we're not having any opposition, the  
motion passes, and I believe that will end this  
agenda items, correct?**

#### **ADJOURNMENT**

Now we are on to Other Business. Is there any  
other business to come before the Board? I  
hope not. I'm not seeing any, so with that is  
there a motion to adjourn? Yes, we do have a  
motion to adjourn, so we are adjourned. Thank  
you, everybody.

(Whereupon the meeting adjourned at 11:25  
a.m. on Tuesday, August 6, 2024)

# ATLANTIC STATES MARINE FISHERIES COMMISSION

## REVIEW OF THE INTERSTATE FISHERY MANAGEMENT PLAN

### FOR ATLANTIC MENHADEN (*Brevoortia tyrannus*)

2023 FISHING YEAR



Prepared by the Plan Review Team



*Sustainable and Cooperative Management of Atlantic Coastal Fisheries*

**REVIEW OF THE ASMFC FISHERY MANAGEMENT PLAN AND STATE COMPLIANCE FOR  
ATLANTIC MENHADEN (*Brevoortia tyrannus*) FOR THE 2023 FISHERY**

**Management Summary**

<u>Date of FMP:</u>	Original FMP: August 1981
<u>Amendments:</u>	Plan Revision: September 1992 Amendment 1: July 2001 Amendment 2: December 2012 Amendment 3: November 2017
<u>Management Unit:</u>	The range of Atlantic menhaden within U.S. waters of the Northwest Atlantic Ocean, from the estuaries eastward to the offshore boundary of the Exclusive Economic Zone (EEZ).
<u>States With Declared Interest:</u>	Maine – Florida, including Pennsylvania
<u>Additional Jurisdictions:</u>	Potomac River Fisheries Commission, National Marine Fisheries Service, United States Fish and Wildlife Service
<u>Active Boards/Committees:</u>	Atlantic Menhaden Management Board, Advisory Panel, Technical Committee, Stock Assessment Subcommittee, Plan Review Team, Plan Development Team, Ecological Reference Point Workgroup
<u>Stock Status:</u>	Not overfished, and overfishing is not occurring relative to the current ecological reference points (2022 Single-Species Stock Assessment Update)

**I. Status of the Fishery Management Plan**

Atlantic menhaden management authority is vested in the states because the vast majority of landings come from state waters. All Atlantic coast states and jurisdictions, with the exception of the District of Columbia, have declared interest in the Atlantic menhaden management program.

The first coastwide fishery management plan (FMP) for Atlantic menhaden was passed in 1981. The FMP did not recommend or require specific management actions, but provided a suite of options should they be needed. In 1992, the plan was revised to include a suite of objectives intended to improve data collection and promote awareness of the fishery and its research needs.

[Amendment 1](#), implemented in 2001, provided specific biological, ecological and socioeconomic management objectives. Addenda I and V revised the biological reference points for menhaden and specified that stock assessments are to occur every three years. Although Amendment 1 did not implement any recreational or commercial management measures, Addenda II through IV instituted a harvest cap on the reduction fishery in Chesapeake Bay. Specifically, Addendum II implemented a harvest cap for 2006-2010 fishing seasons; before its first year of implementation, Addendum III revised the cap amount to be the average landings from 2001 to 2005 (or 109,020 mt); and Addendum IV extended the provisions of Addendum III through 2013.

[Amendment 2](#), implemented in 2012, established a 170,800 metric ton (mt) total allowable catch (TAC) for the commercial fishery beginning in 2013. This TAC represented a 20% reduction from average landings between 2009 and 2011. This Amendment also used the 2009-2011 period to allocate the TAC among jurisdictions. Additionally, the Amendment established timely reporting requirements for commercial landings and required states to be accountable for their respective quotas by paying back any overages the following year. Amendment 2 also included provisions that allowed for the transfer of quota between jurisdictions and a bycatch allowance of 6,000 pounds per day for non-directed fisheries that operate after a jurisdiction's quota has been landed. Addendum 1 to Amendment 2 allows two licensed individuals to harvest up to 12,000 pounds of menhaden bycatch when working from the same vessel using stationary multi-species gear; the intent of this provision is to accommodate cooperative fishing practices that traditionally take place in Chesapeake Bay. The Amendment also reduced the Chesapeake Bay reduction fishery harvest cap by 20% to 87,216 mt.

Amendment 2 also enabled the Board to set aside 1% of the coastwide TAC for episodic events. Episodic events are times and areas where Atlantic menhaden are available in more abundance than they normally occur. Technical Addendum I to Amendment 2 established a mechanism for New England states from Maine to Connecticut<sup>1</sup> to use the set aside, which includes a qualifying definition of episodic events, required effort controls to scale a state's fishery to the set aside amount, and a timely reporting system to monitor the set aside. Any unused set aside quota as of October 31 is redistributed to jurisdictions on November 1 based on the Amendment 2 allocation percentages.

In 2015, the TAC was increased by 10% to 187,880 mt for the 2015 and 2016 fishing years. In 2016, the Board again increased the TAC by 6.45% to 200,000 mt for the 2017 fishing year.

Atlantic menhaden are managed under [Amendment 3](#). Approved in November 2017, the Amendment maintained the management program's single-species biological reference points until the review and adoption of menhaden-specific ecological reference points (ERPs) as part of the 2019 benchmark stock assessment process. In doing so, the Board placed development of menhaden-specific ERPs as its highest priority and supports the efforts of the ERP Workgroup to reach that goal. Amendment 3 also changed commercial quota allocations in order to strike

---

<sup>1</sup> At its May 2016 meeting, the Board added New York as an eligible state to harvest under the set aside.

an improved balance between gear types and jurisdictions. The Amendment allocated a baseline quota of 0.5% to each jurisdiction, and allocated the rest of the TAC based on average landings between 2009 and 2011. This measure provides fishing opportunities to states that had little quota under Amendment 2, while still recognizing historic landings in the fishery. States also have the option to relinquish all or part of its quota which is then redistributed to the other jurisdictions based on the 2009-2011 landings period. The Amendment also prohibits the rollover of unused quota; maintains the quota transfer process; maintains the bycatch provision (which was rebranded as the ‘incidental catch/small-scale fisheries’ (IC/SSF) provision and applicable gear types were defined) and the episodic event set aside program (EESA) for the states of Maine – New York. Finally, the Amendment reduced the Chesapeake Bay cap to 51,000 mt, recognizing the importance of the Chesapeake Bay as nursery grounds for many species by capping recent reduction landings from the Bay at current levels.

[Addendum I](#), implemented in 2023, modifies Amendment 3 by creating a three-tiered system for minimum allocations to the states, with Pennsylvania receiving 0.01%; South Carolina, Georgia, Connecticut, Delaware, North Carolina, and Florida receiving 0.25%; and the remaining states continuing to receive a minimum of 0.5%. Furthermore, the Addendum allocates the remainder of the TAC, excluding the 1% reserved for the EESA, on a state-by-state basis based on landings history of the fishery from 2018, 2019, and 2021. Regarding the IC/SSF provision, the Addendum codifies the ability for states to elect to divide their quotas into sectors, enabling individual sectors to enter into the provision at different times. Additionally, the Addendum removes purse seines as a permitted small-scale directed gear, thereby, prohibiting them from harvesting under the IC/SSF provision. Finally, the Addendum counts IC/SSF landings against the TAC and if IC/SSF landings cause the TAC to be exceeded, then the Board must take action to modify one or both of permitted gear types and trip limits under the provision.

State	Addendum 1 Allocations (%)
ME	4.80%
NH	1.19%
MA	2.12%
RI	0.81%
CT	0.33%
NY	0.84%
NJ	11.00%
PA	0.01%
DE	0.27%
MD	1.17%
PRFC	1.09%
VA	75.21%
NC	0.37%
SC	0.25%
GA	0.25%
FL	0.29%

In August 2020, the Board formally approved the use of ERPs to manage Atlantic menhaden, with Atlantic striped bass as the focal species in maintaining their population. Atlantic striped bass was chosen for the ERP definitions because it was the most sensitive predator fish species to Atlantic menhaden harvest, so an ERP target and threshold sustaining striped bass would likely provide sufficient forage for other predators under current ecosystem conditions. For the development of the ERPs, all other focal species in the model (bluefish, weakfish, spiny dogfish, and Atlantic herring) were assumed to be fished at 2017 levels.

In November 2022, the Board approved a TAC for 2023-2025 of 233,550 mt, based on the ERPs. The new TAC represents a 20% increase from the 2021-2022 TAC level. Based on projections, the probability of exceeding the ERP fishing mortality target of 0.19 is 2% in 2023, 22% in 2024, and 28.5% in 2025.

## II. Status of the Stock

In February 2020, the Board accepted the results of the [Single-Species](#) and [Ecological Reference Point \(ERP\)](#) Benchmark Stock Assessments and Peer Review Reports for management use. These assessments were peer-reviewed and approved by an independent panel of scientific experts through the 69<sup>th</sup> SouthEast, Data, Assessment and Review (SEDAR) workshop. The single-species assessment acts as a traditional stock assessment using the Beaufort Assessment Model (BAM), a statistical catch-at-age model that estimates population size-at-age and recruitment. According to the model, the stock is not overfished or experiencing overfishing relative to the current single-species reference points.

The ERP assessment evaluates the health of the stock in an ecosystem context, and indicates the fishing mortality rate ( $F$ ) reference points for menhaden should be lower to account for the species' role as a forage fish<sup>2</sup>. The ERP assessment uses the Northwest Atlantic Coastal Shelf Model of Intermediate Complexity for Ecosystems (NWACS-MICE) to develop Atlantic menhaden ERPs. NWACS-MICE is an ecosystem model that focuses on four key predator species (striped bass, bluefish, weakfish, and spiny dogfish) and three key prey species (Atlantic menhaden, Atlantic herring, and bay anchovy). These species were chosen because diet data indicate they are top predators of Atlantic menhaden or are key alternate prey species for those predators.

The ERP assessment indicates the  $F$  reference points for menhaden should be lower than the single-species reference points, but it also concluded that the final ERP definitions, including the appropriate harvest level for menhaden, depend on the management objectives for the ecosystem (i.e., management objectives for both Atlantic menhaden and its predators). Accordingly, instead of proposing a specific ERP definition, the assessment recommends a combination of the BAM and the NWACS-MICE models as a tool for managers to evaluate trade-offs between menhaden harvest and predator biomass.

Atlantic menhaden are now managed by menhaden-specific ERPs as indicated above. The ERP target is the maximum  $F$  on Atlantic menhaden that sustains Atlantic striped bass at their biomass target when striped bass are fished at their  $F$  target, a measure of the intensity with which the population is being fished, is used to evaluate whether the stock is experiencing overfishing. The ERP threshold is the maximum  $F$  on Atlantic menhaden that keeps Atlantic striped bass at their biomass threshold when striped bass are fished at their  $F$  target. Population fecundity, a measure of reproductive capacity, is used to evaluate whether the stock

---

<sup>2</sup> it should be noted, however, that the conservative TAC the Board has set for recent years is consistent with the ERP  $F$  target provided in the ERP Assessment

is overfished. According to the 2022 single-species stock assessment update, the 2021 estimate of fecundity was above both the ERP FEC target and threshold, and the 2021 estimate of fishing mortality was below the ERP F target and threshold, indicating the stock was neither overfished nor experiencing overfishing. The next ERP benchmark stock assessment and single-species assessment update are underway and scheduled to be presented to the Board in 2025.

### **III. Status of the Fishery**

#### *Commercial*

Total commercial Atlantic menhaden landings in 2023, including directed, incidental catch, and EESA landings, are estimated at 166,844 mt (367.8 million pounds), an approximate 15% decrease relative to 2022 and 71.4% of the coastwide commercial TAC of 233,550 mt (514.9 million pounds). There were no reported landings from the incidental catch fishery in 2023 (Table 1).

#### *Reduction Fishery*

The 2023 harvest for reduction purposes is estimated at 117,019 mt (258 million pounds), a 13% decrease from 2022 and 15% below the previous 5-year average of 137,583 mt (303.3 million pounds) (Table 2; Figure 3). Omega Protein's plant in Reedville, Virginia, is the only active Atlantic menhaden reduction factory on the Atlantic coast.

#### *Bait Fishery*

The coastwide bait harvest estimate for 2023 from state compliance reports, including directed, incidental catch, and EESA landings, is 49,825 mt (109.8 million pounds). This represents a 17% decrease relative to 2022 and a 13% decrease compared to the previous 5-year average (Table 2; Figure 3). New Jersey (37%), Maine (27%), Virginia (24%), and New Hampshire (4%) landed the four largest shares in 2023.

#### *Incidental Catch and Small-Scale Fisheries Landings*

There were no reported landings from the incidental catch fishery in 2023 (Table 4).

#### *Episodic Events Set Aside Program*

The 2023 EESA quota was 2,317 mt (5.1 million pounds), including a deduction of 40,723 pounds from an overage in 2022. Maine began harvesting under the EESA program on September 4<sup>th</sup> and continued until their EESA fishery closed on October 31<sup>st</sup>. Preliminary estimates reported landings of 2,622,635 pounds. Based on the preliminary estimate, 2,485,538 pounds of leftover set aside was redistributed to the states on November 3<sup>rd</sup>. However, late reporting resulted in a final estimate of 1,274 mt (2.8 million pounds) landed under the EESA fishery (Table 5), resulting in an overage of 185,538 pounds. In December 2023, January 2024, and July 2024, Maine transferred a total of 185,538 pounds to cover the overage (see Table 7).

#### *Chesapeake Bay Reduction Fishery Cap (cap)*

Amendment 3 implemented a 51,000 mt harvest cap for the reduction fishery in the Chesapeake Bay. The cap for 2023 was set once again at 51,000 mt with harvest remaining

under the limit in 2022. Reported reduction landings from Chesapeake Bay in 2023 were less than 40,000 mt, which is below the cap.

#### *Recreational*

Menhaden are important bait in many recreational fisheries; some recreational fishermen use cast nets to capture menhaden or snag them with hook and line for use as bait, both dead and alive. The Marine Recreational Information Program (MRIP) estimate for Atlantic menhaden harvest (A + B1) in 2023 is 3.9 million pounds (PSE of 20.6) which is a 55% decrease from 2022 (8.8 million pounds).

Additionally, it is important to note recreational harvest is not well captured by MRIP because there is not a known, identified direct harvest for menhaden, other than for bait. MRIP intercepts typically capture the landed fish from recreational trips as fishermen come to the dock or beach. However, since menhaden caught by recreational fishermen are often used as bait during their trip, they are typically not part of the catch that is seen by the surveyor completing the intercept.

#### *Quota Transfers*

There were 5 state-to-state transfers in 2023 (Table 8), a decrease from 24 in 2022. Quota transfers were generally pursued to ameliorate overages. One of the purposes of the commercial allocation changes in Addendum I to Amendment 3 was to reduce the need for quota transfers, and the PRT notes the significant decrease in transfers from 2022 to 2023.

### **IV. Status of Research and Monitoring**

#### Commercial fisheries monitoring

Reduction fishery - The NMFS Southeast Fisheries Science Center Beaufort Laboratory in Beaufort, North Carolina, continues to monitor landings and collect biological samples from the Atlantic menhaden purse-seine reduction fishery. The Beaufort Laboratory processes and ages all reduction samples collected on the East Coast. In addition, the purse-seine reduction fishery continues to provide Captains Daily Fishing Reports (CDFRs) to the Beaufort Laboratory where NMFS personnel enter data into a database for storage and analysis.

Bait fishery - Per Amendment 3, states are required to implement a timely quota monitoring system to maintain menhaden harvest within the TAC and minimize the potential for quota overages. The Standard Atlantic Fisheries Information System (SAFIS) daily electronic dealer reporting system allows near real time data acquisition for federally permitted bait dealers in the Mid-Atlantic and Northeast. Landings by Virginia's purse-seine for-bait vessels (snapper rigs) in Chesapeake Bay are tabulated at season's end using CDFRs maintained on each vessel during the fishing season. A bait-fishery sampling program for size and age composition has also been conducted since 1994. The Beaufort Laboratory, and some states, age the bait samples collected. See *Section VII* for more information on quota monitoring and biological sampling requirements.

#### Atlantic menhaden research



The following studies relevant to menhaden assessment and management have been published within the last few years:

- Anstead, K. A., K. Drew, D. Chagaris, A. M. Schueller, J. E. McNamee, A. Buchheister, G. Nessler, J. H. Uphoff Jr., M. J. Wilberg, A. Sharov, M. J. Dean, J. Brust, M. Celestino, S. Madsen, S. Murray, M. Appelman, J. C. Ballenger, J. Brito, E. Cosby, C. Craig, C. Flora, K. Gottschall, R. J. Latour, E. Leonard, R. Mroch, J. Newhard, D. Orner, C. Swanson, J. Tinsman, E. D. Houde, T. J. Miller, and H. Townsend. 2021. The path to an ecosystem approach for forage fish management: A case study of Atlantic menhaden. *Front. Mar. Sci.* 8: 607657.
- Chagaris D., K. Drew, A. M. Schueller, M. Cieri, J. Brito, and A. Buchheister. 2020. Ecological Reference Points for Atlantic Menhaden Established Using an Ecosystem Model of Intermediate Complexity. *Front. Mar. Sci.* 7:606417.
- Deyle, E., A. M. Schueller, H. Ye, G. M. Pao, and G. Sugihara. 2018. Ecosystem-based forecasts of recruitment in two menhaden species. *Fish and Fisheries* 19(5): 769-781.
- Drew, K., M. Cieri, A. M. Schueller, A. Buchheister, D. Chagaris, G. Nessler, J. E. McNamee, and J. H. Uphoff. 2021. Balancing Model Complexity, Data Requirements, and Management Objectives in Developing Ecological Reference Points for Atlantic Menhaden. *Front. Mar. Sci.* 8: 608059.
- Liljestrand, E.M., M.J. Wilberg, and A.M. Schueller. 2019. Estimation of movement and mortality of Atlantic menhaden during 1966-1969 using a Bayesian multi-state mark recapture model. *Fisheries Research* 210: 204-213.
- Liljestrand, E.M., M. J. Wilberg, and A. M. Schueller. 2019. Multi-state dead recovery mark-recovery model performance for estimating movement and mortality rates. *Fisheries Research* 210: 214-233.
- Lucca, B. M., and J. D. Warren. 2019. Fishery-independent observations of Atlantic menhaden abundance in the coastal waters south of New York. *Fisheries Research* 218: 229-236.
- Nessler, G. M., and M. J. Wilberg. 2019. A performance evaluation of surplus production models with time-varying intrinsic growth in dynamic ecosystems. *Canadian Journal of Fisheries and Aquatic Sciences* 76(12): 2245-2255.
- Schueller, A.M., A. Rezek, R. M. Mroch, E. Fitzpatrick, and A. Cheripka. 2021. Comparison of ages determined by using an Eberbach projector and a microscope to read scales from Atlantic menhaden (*Brevoortia tyrannus*) and Gulf menhaden (*B. patronus*). *Fishery Bulletin* 119(1): 21-32.

Theses and Dissertations of Potential Interest:

- McNamee, J. E. 2018. A multispecies statistical catch-at-age (MSSCAA) model for a Mid-Atlantic species complex. University of Rhode Island.

## **V. Implementation of FMP Compliance Requirements**

All states are required to submit annual compliance reports by August 1.

### *Quota Results*

The Board set the TAC at 233,550 mt (514.9 million pounds) for 2023-2025 based on the adopted ERPs. 1% is set aside for episodic events. States may relinquish all or part of its annual quota by December 1<sup>st</sup> of the previous year. Delaware relinquished one million pounds of quota, which was redistributed to the states according to procedures outlined in Addendum I to Amendment 3 and is reflected in the 2024 Preliminary Quota in Table 7.

Table 7 also contains 2023 state-specific quotas and directed harvest. The final quotas for 2023 account for one million pounds of quota relinquished by Delaware, state-to-state transfers (Table 8), and transfers to the EESA. Based on preliminary 2023 landings, Maine incurred an overage of 807,216 pounds, which was deducted from their 2024 quota.

### *Quota Monitoring*

The Board approved timely quota monitoring programs for each state through implementation of Amendment 3. Monitoring programs are intended to minimize the potential for quota overages. Table 6 contains a summary of each state's approved quota monitoring system.

Menhaden purse seine and bait seine vessels (or snapper rigs) are required to submit CDFRs. Maine, New York, and Virginia fulfilled this requirement in 2023. New Jersey did not require purse seine vessels to fill out the specific CDFR but did require monthly trip level reporting on state forms that include complementary data elements to the CDFR. Rhode Island purse seine vessels must call in daily reports to RI DMF and fill out daily trip level logbooks. New Hampshire also does not require the specific CDFR, but does require daily, trip-level reporting from dealers and monthly trip-level reporting from harvesters. Massachusetts requires trip level reporting for all commercial fishermen. Menhaden purse seine fisheries do not currently operate in all other jurisdictions in the management unit.

### *Biological Monitoring Requirements*

Amendment 3 maintains biological sampling requirements for non *de minimis* states as follows:

- One 10-fish sample (age and length) per 300 mt landed for bait purposes for Maine, New Hampshire, Massachusetts, Rhode Island, Connecticut, New York, New Jersey, and Delaware; and
- One 10-fish sample (age and length) per 200 mt landed for bait purposes for Maryland, Potomac River Fisheries Commission, Virginia, and North Carolina

Table 9 provides the number of 10-fish samples required and collected for 2023. These are based on the best available 2023 total bait landings data (including directed, incidental, and EESA landings) provided to the Commission by the states. In 2023, Connecticut fell short of the requirement, failing to collect one required sample. However, Connecticut noted the fishery-independent samples collected from the Long Island Sound Trawl Survey, which produced 100 age and 525 length samples over 158 tows.

The PRT continued to discuss whether a sufficient number of age and length samples are being collected from different commercial gear types as well as regions, and whether substituting samples from fishery-independent sources is appropriate for meeting the requirement. The Stock Assessment Subcommittee will evaluate the biological sampling as part of the 2025 single-species assessment update.

#### *Adult CPUE Index Requirement*

Amendment 3 requires that, at a minimum, each state with a pound net fishery must collect catch and effort data elements for Atlantic menhaden as follows; total pounds landed per day, number of pound nets fished per day. These are harvester trip level ACCSP data requirements. In May of 2013, the Board approved North Carolina's request to omit this information on the basis that it did not have the current reporting structure to require a quantity of gear field by harvesters or dealers. In recent years, NC DMF staff have worked to develop a proxy method to estimate effort but this approach likely would not work for developing an adult CPUE index.

#### *De Minimis Status*

To be eligible for *de minimis* status, a state's bait landings must be less than 1% of the total coastwide bait landings for the most recent two years. State(s) with a reduction fishery are not eligible for *de minimis* consideration. If granted *de minimis* status by the Board, states are exempt from implementing biological sampling as well as pound net catch and effort data reporting. The Board also previously approved a *de minimis* exemption for New Hampshire, South Carolina and Georgia from implementation of timely reporting. The states of Pennsylvania, South Carolina, Georgia, and Florida requested and qualify for *de minimis* status for the 2023 fishing season.

## **VI. Plan Review Team Recommendations and Notable Comments**

### Management Recommendations

- The PRT recommends that the *de minimis* requests from Pennsylvania, South Carolina, Georgia, and Florida, be approved.

## VII. Literature Cited

Atlantic States Marine Fisheries Commission (ASMFC). 2022. Atlantic Menhaden Stock Assessment Update. Prepared by the ASMFC Atlantic Menhaden Stock Assessment Subcommittee. 127 pp.

Southeast Data, Assessment, and Review (SEDAR). 2015. SEDAR 40 – Atlantic Menhaden Stock Assessment Report. SEDAR, North Charleston SC. 643 pp.

SEDAR. 2020. SEDAR 69 – Atlantic Menhaden Benchmark Stock Assessment Report. SEDAR, North Charleston SC. 691 pp. available online at: <http://sedarweb.org/sedar-69>

SEDAR. 2020. SEDAR 69 - Atlantic Menhaden Ecological Reference Points Stock Assessment Report. SEDAR, North Charleston SC. 560 pp. available online at: <http://sedarweb.org/sedar-69>

Table 1. Directed, bycatch, and episodic events set aside landings in 1000s of pounds for 2023 by jurisdiction. Source: 2023 ASMFC state compliance reports for Atlantic menhaden. NA = not applicable; C = confidential

State	Directed	Incidental Catch	EESA
ME	26,456	-	2,808
NH	4,376	-	-
MA	2,972	-	-
RI	160	-	-
CT	200	-	-
NY	650	-	-
NJ	40,857	-	NA
DE	47	-	NA
MD	2,001	-	NA
PFRC	2,051	-	NA
VA	284,270	-	NA
NC	826	-	NA
SC	0	-	NA
GA	0	-	NA
FL	155	-	NA

Table 2. Atlantic menhaden reduction and bait landings in thousand metric tons, 1989-2023.

	<b>Reduction Landings (1000 mt)</b>	<b>Bait Landings (1000 mt)</b>
<b>1989</b>	284	31.5
<b>1990</b>	343	28.1
<b>1991</b>	330	29.7
<b>1992</b>	270	33.8
<b>1993</b>	310	23.4
<b>1994</b>	260	25.6
<b>1995</b>	340	28.4
<b>1996</b>	293	21.7
<b>1997</b>	259	24.2
<b>1998</b>	246	38.4
<b>1999</b>	171	34.8
<b>2000</b>	167	33.5
<b>2001</b>	234	35.3
<b>2002</b>	174	36.2
<b>2003</b>	166	33.2
<b>2004</b>	183	34.0
<b>2005</b>	147	38.4
<b>2006</b>	157	27.2
<b>2007</b>	174	42.1
<b>2008</b>	141	47.6
<b>2009</b>	144	39.2
<b>2010</b>	183	42.7
<b>2011</b>	174	52.6
<b>2012</b>	161	63.7
<b>2013</b>	131	37.0
<b>2014</b>	131	41.6
<b>2015</b>	143	45.8
<b>2016</b>	137	43.1
<b>2017</b>	129	43.8
<b>2018</b>	141	50.2
<b>2019</b>	151	58.1
<b>2020</b>	125	59.6
<b>2021</b>	137	58.4
<b>2022</b>	134	60.1
<b>2023</b>	117	49.8
<b>Avg 2018-2022</b>	138	57.3

Table 3. Incidental fishery landings by state in 1000s of pounds, 2013-2023. Only states that have reported incidental catch landings are listed. Average total incidental catch landings for the time series is 7.7 million pounds.

State	2013	2014	2015	2016	2017	2018	2019	2020	2021	2022	2023
ME		-	-	506	5,374	2,995	10,751	13,605	11,771	15,602	-
MA								49	174	595	-
RI	16	99	70	40	136	-	-	-	C	-	-
CT	0	-	10	-	124	-	-	-	C	-	-
NY	0	325	769	281	807	-	-	282	310	-	-
NJ	0	626	241	196	-	204,240	-	20	C	-	-
DE	76	112	92	21	29	-	-	-	-	-	-
MD	2,864	2,201	1,950	996	-	-	-	-	-	-	-
PRFC	1,087	1,112	455	106	670	-	-	-	-	-	-
VA	268	2,232	2,103	326	-	110,281	-	-	-	1,784	-
FL	65	126	302	111	264	-	-	-	-	-	-
<b>Total</b>	<b>4,377</b>	<b>6,831</b>	<b>5,992</b>	<b>2,581</b>	<b>7,404</b>	<b>3,215</b>	<b>10,751</b>	<b>13,957</b>	<b>12,336</b>	<b>16,152</b>	<b>0</b>

Table 4. Total incidental landings (1000s of pounds), number of trips, and number of states reporting landings in the incidental catch fishery, 2013-2023.

Year	Landings (1000s of pounds)	Number of Trips	Number of states landing
2013	4,377	2,783	6
2014	6,831	5,275	8
2015	5,992	4,498	9
2016	2,581	2,222	9
2017	7,407	2,108	7
2018	3,310	1,224	3
2019	10,751	3,113	1
2020	13,957	3,565	4
2021	12,336	3,099	6
2022	17,980	4,134	3
2023	0	0	0
<b>Total</b>	<b>85,522</b>	<b>32,021</b>	

Table 5. Episodic Events Set-Aside (EESA) fishery quota, landings, and participating states by year. \*The 2022 overage was partially covered by a quota transfer and the remainder was deducted from the 2023 set aside.

Year	States Declared Participation	EESA Quota (MT)	Landed (MT)	% EESA Quota Used
2013		1,708	-	-
2014	RI	1,708	134	7.8%
2015	RI	1,879	854	45.5%
2016	ME, RI, NY	1,879	1,728	92.0%
2017	ME, RI, NY	2,000	2,129	106.5%
2018	ME	2,031	2,103	103.6%
2019	ME	2,160	1,995	92.4%
2020	ME & MA	2,160	2,080	96.3%
2021	ME, MA, RI	1,944	2,213	113.8%
2022	ME, MA	1,944	1,992	102.4%
2023*	ME	2,317	1,274	55.0%



Table 6. State quota reporting timeframes in 2023. The **bold** text indicates which reporting program (dealer or harvesters) the states use to monitor its quotas. **Blue text** indicates changes from 2022.

State	Dealer Reporting	Harvester Reporting	Notes
ME	monthly	<b>daily/weekly</b>	Harvesters must report same day during directed and episodic event trips; harvesters report daily trips weekly for trips <6,000 lbs. Harvest reports are used for quota monitoring.
NH	<b>daily</b>	monthly	Exempt from timely reporting. Implemented daily, transaction level reporting for state dealers.
MA	<b>weekly</b>	monthly/daily	Harvesters landing greater than 6,000 lbs must report daily
RI	<b>twice weekly</b>	quarterly/daily	Harvesters using purse seines must report daily
CT	<b>weekly/monthly</b>	monthly/daily	CT operates as directed fisheries until 90% of the quota is harvested. Then operates at the 6,000 pound bycatch trip limit.
NY	<b>Weekly</b>	monthly	Capability to require weekly harvester reporting if needed
NJ	<b>weekly</b>	monthly	All menhaden sold or bartered must be done through a licensed dealer
DE	—	<b>monthly/daily</b>	Harvesters landing menhaden report daily using IVR
MD	monthly	<b>monthly/daily</b>	PN harvest is reported daily, while other harvest is reported monthly.
PRFC	—	<b>weekly</b>	Trip level harvester reports submitted weekly. When 70% of quota is estimated to be reached, then pound netters must call in weekly report of daily catch.
VA	—	<b>monthly/weekly/daily</b>	Purse seines submit weekly reports until 97% of quota, then daily reports. Monthly for all other gears until 90% of quota, then reporting every 10 days.
NC	<b>monthly (combined reports)</b>		Single trip ticket with dealer and harvester information submitted monthly. Larger dealers (>50,000 lbs of landings annually) can report electronically, updated daily.
SC	<b>monthly (combined reports)</b>		Exempt from timely reporting. Single trip ticket with dealer and harvester information.
GA	<b>monthly (combined reports)</b>		Exempt from timely reporting. Single trip ticket with dealer and harvester information.
FL	<b>monthly/weekly (combined reports)</b>		Monthly through the FWC Marine Fisheries Trip Ticket system until 75% of quota is projected to have been met, then weekly phone calls to dealers who have been reporting menhaden landings until the directed fishery is closed.

Table 7. Results of 2023 quota accounting in pounds. The 2024 base quotas account for the redistribution of relinquished quota by Delaware (1 million pounds).

State	2023 Base Quota*	Returned Set Aside	Transfers^	Final 2023 Quota	Overages	2024 Base Quota*
ME	24,510,314	113,697	1,025,000	25,649,011	867,754**	23,642,560
NH	6,052,530	18,140		6,070,670		6,052,530
MA	10,838,902	42,919	-100,000	10,781,821		10,838,902
RI	4,147,882	8,279	-300,000	3,856,161		4,147,882
CT	1,472,767	2,170	-750,000	724,937		1,693,471
NY	4,298,217	9,057		4,307,274		4,298,217
NJ	56,172,891	277,616		56,450,507		56,172,891
PA	50,974	-		50,974		50,974
DE	375,998	527		376,526		375,998
MD	5,947,968	17,598		5,965,566		5,947,968
PRFC	5,547,544	15,525	-2,000,000	3,562,968		5,547,444
VA	384,164,855	1,975,692	2,000,000	388,140,547		384,172,558
NC	1,892,146	3,198		1,895,344		1,892,146
SC	1,274,601	1		1,274,603		1,274,601
GA	1,274,352	-		1,274,352		1,274,352
FL	1,490,464	1,119		1,491,583		1,490,464
<b>Total</b>	<b>509,387,305</b>	<b>2,485,538</b>		<b>512,226,250</b>		<b>508,872,958</b>

\*Includes redistributed relinquished quota for that year and any overages from the previous season.

\*\*Includes 2023 directed fishery overage and transfer of 2024 quota to EESA to ameliorate overage in 2023 EESA from late reporting.

^Includes inter-state transfers and transfers to the EESA quota.

Table 8. State-to-state transfers of menhaden commercial quota for the 2023 Fishing year.

Transfer Date	ME	NH	MA	RI	CT	NY	NJ	PA	DE	MD	PRFC	VA	NC	SC	GA	FL
8/24/2023											7,703	(7,703)				
10/11/2023											(2,000,000)	2,000,000				
10/13/2023	750,000				(750,000)											
12/21/2023	300,000			(300,000)												
1/26/2024	100,000		(100,000)													
<b>Total</b>	1,025,000	-	(100,000)	(300,000)	(750,000)	-	-	-	-	-	(1,992,297)	1,992,297				

Table 9. Biological monitoring results for the 2023 Atlantic menhaden bait fishery.

\*Age samples are still being processed

State	#10-fish samples required	#10-fish samples collected	Age samples collected	Length samples collected	Gear/Comments
ME	47	55	550	550	50 samples from directed fishery, 5 during EESA; 47 samples from purse seines, 8 samples gillnets
NH	7	7	70	70	Purse Seine
MA	4	10	100	100	All purse seine
RI	1	1	10	10	Otter Trawl (42 additional FI samples available)
CT	1	-	-	-	Long Island Sound Trawl Survey - 158 tows in 2023; collected 100 age/525 length samples
NY	1	16	161	161	cast net, seine net
NJ	58	85	85	850	Purse Seine
	3	3	3	30	Other Gears
DE	1	1	10	10	Gill net
MD	5	26	455	1,095	Pound net
PRFC	5	8	80	80	pound net
VA	3	5	56	56	Pound Net
	2	50	502	502	Gill Net
	-	12	120	120	haul seine
NC	2	9	86	236	gillnet
<b>Total</b>	<b>140</b>	<b>288</b>	<b>2200</b>	<b>3870</b>	

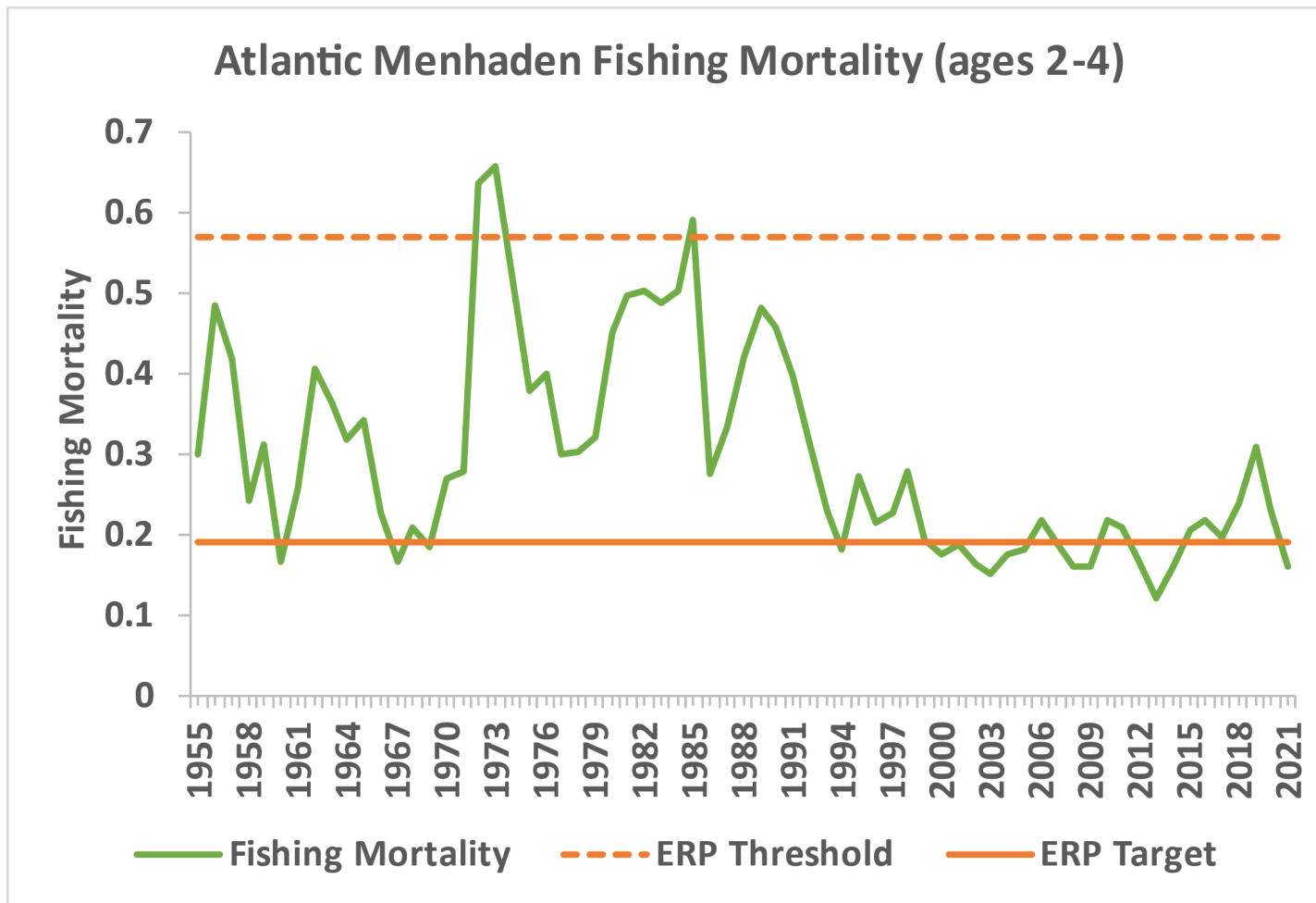


Figure 1. Fishing mortality, 1955-2021. The ERP fishing mortality reference points are  $F_{\text{target}} = 0.19$  and  $F_{\text{threshold}} = 0.57$ .  $F_{2017} = 0.16$ . Source: ASMFC 2022.

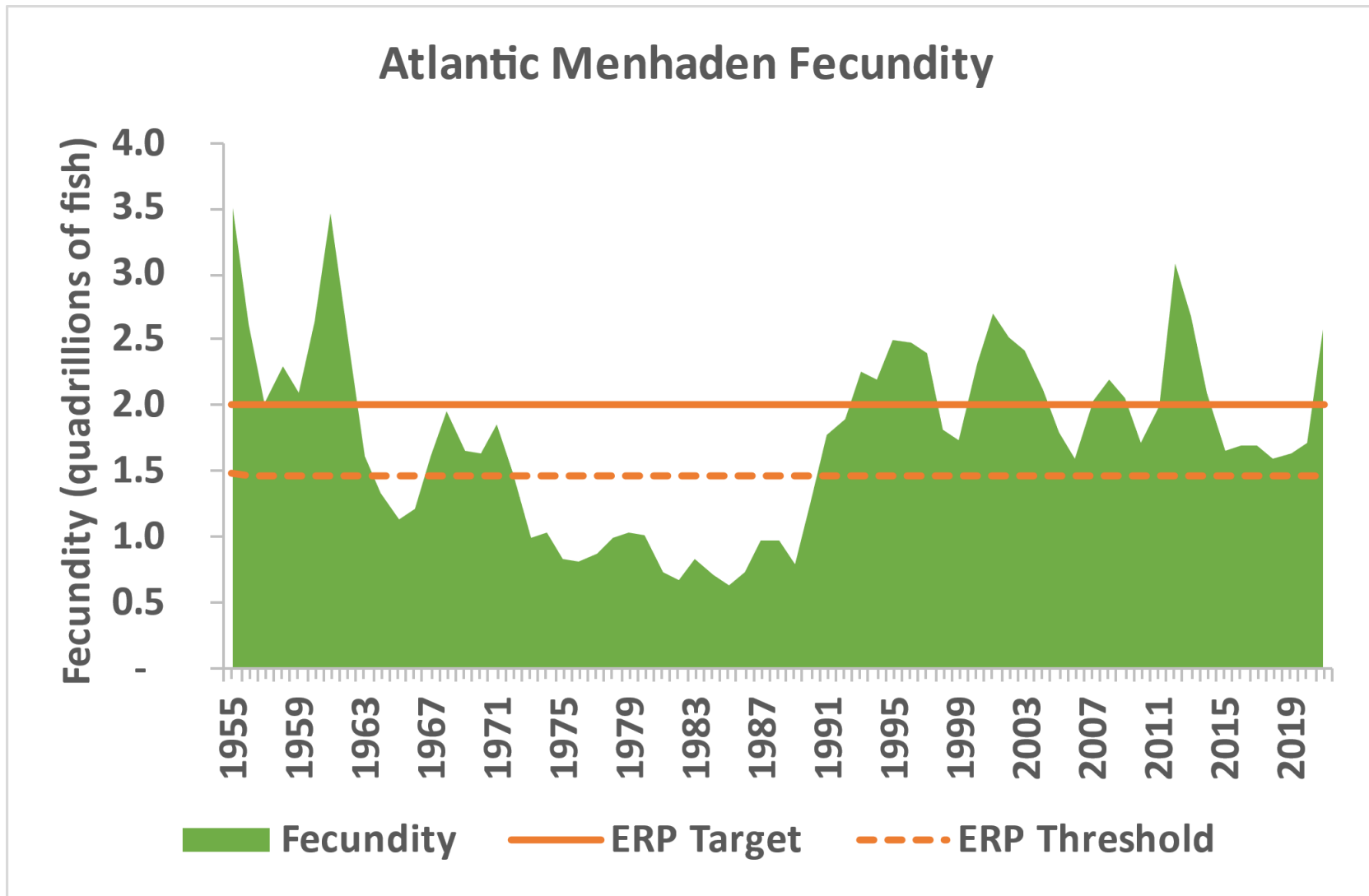


Figure 2. Atlantic menhaden fecundity, 1955-2021. The ERPs for population fecundity are  $FEC_{target} = 2,003,986$  (billions of eggs), and  $FEC_{threshold} = 1,492,854$  (billions of eggs). Source: ASMFC 2022.

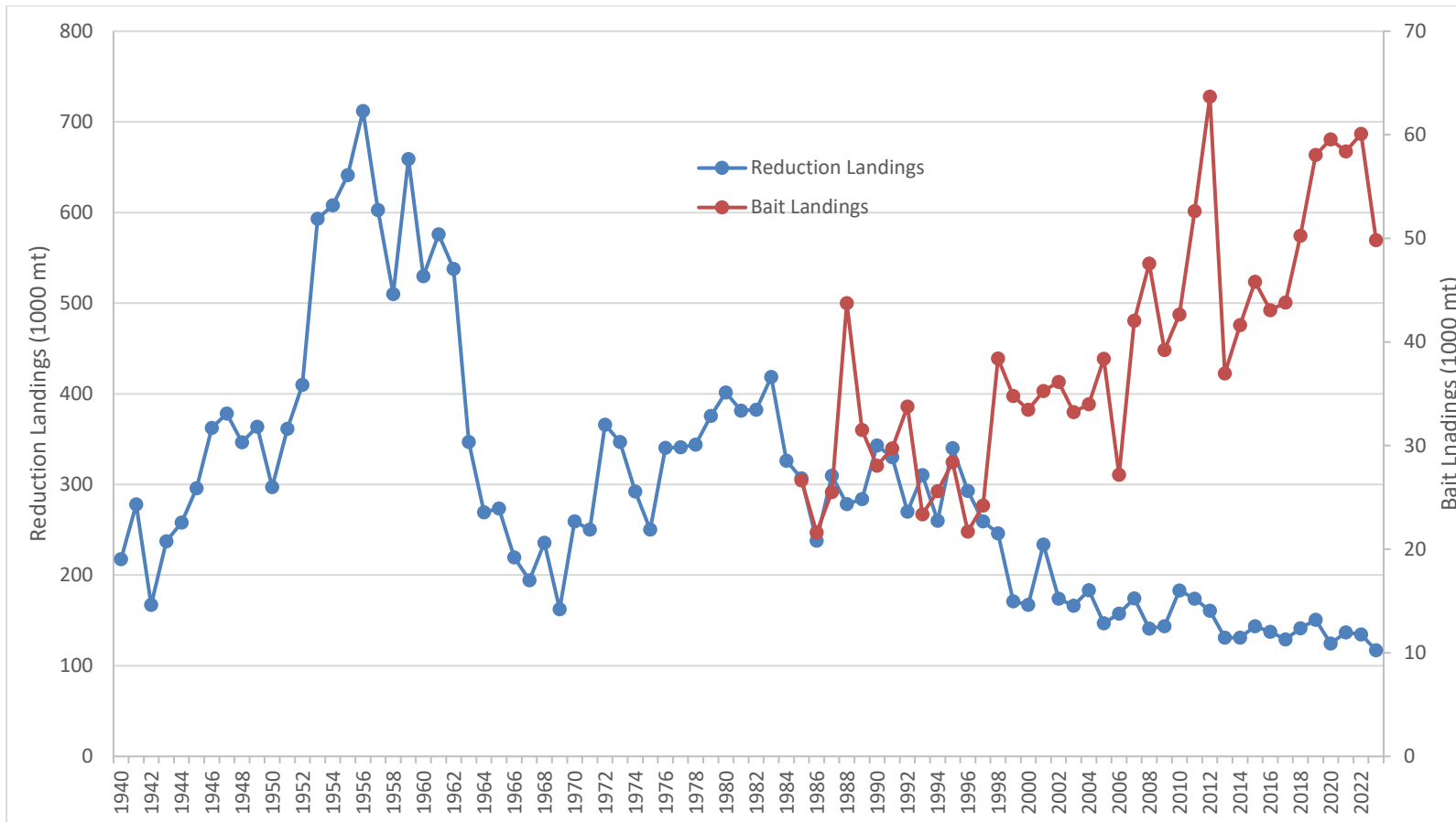


Figure 3. Landings from the reduction purse seine fishery (1940–2023) and bait fishery (1985–2023) for Atlantic menhaden. Note: there are two different scales on the y-axes.

## James Boyle

---

**From:** tomoko hamada <hamada.tomoko.san@gmail.com>  
**Sent:** Wednesday, September 18, 2024 4:28 PM  
**To:** John Clark; Caitlin Craig; Meghan Lapp  
**Cc:** James Boyle  
**Subject:** [External] Atlantic Menhaden 2024 Latest osprey report

ASMFC Menhaden Management board Please Distribute to Atlantic Menhaden working group in preparation for ASMFC October meeting.

Please include this as public comments before the upcoming October meeting. Thank you.

Dear Menhaden Management board and menhaden working group members .

I am a professor emerita of the College of William and Mary, Ph.d., who lives at 1076 Sand Bank Rd, Port Haywood, VA 23138 that faces the Chesapeake Bay. I have been an osprey observer and a citizen scientist member of [Osprey-watch.org](https://www.osprey-watch.org), which is a global community of observers focused on breeding osprey. The mission of Osprey-watch is to collect information on a large enough spatial scale to be useful in addressing most pressing issues facing aquatic ecosystems that include depletion of fish stocks and environmental degradation.

The Chesapeake is the world's largest osprey breeding ground. Live fish make up almost 99% of the osprey diet. In the lower Bay with waters above 10 ppt salinity, osprey pairs has been suffering due to very low menhaden stocks, while those nesting in the upper Bay continue to grow, partly because the States facing the Upper Bay waters (Maryland, Delaware, New Jersey, New York) have already banned commercial menhaden fishing and because the Upper Bay osprey can depend on other fish species (gizzard shad & blue/channel catfish) besides menhaden.

In the Mobjack Bay near my house, the osprey story is heart-breaking. In June 2022, the Center for Conservation Biology researchers at William and Mary found that only three chicks out of 84 nests in the Mobjack Bay were alive. The rest had starved to death. In 2023 the Center found that only 21 young among 167 nests were alive in the lower Bay. The fish delivery rate has declined despite the fact that male osprey spending more hunting effort to catch them. The current low reproductivity of osprey is worse than the worst of the DDT era.

In summer 2023, together with some 80 Virginians, I organized the OspreyWatch Alliance which is a group of private citizens who are very much concerned about the crisis of ospreys in our back water and who want to do something to save ospreys.

This year, in September 2024, the Center for Conservation Biology has compiled 2024 breeding performance results for osprey.

The CCB researchers' monitoring efforts included 511 osprey pairs distributed among twelve study areas. Nine study areas where salinity exceeded 10 ppt were selected as the main sample data, while two study areas on upper tributaries where salinity was less than 1ppt were used as reference sites for comparison. Cameras were mounted on a subsample of nests within all study areas to quantify diet and brood provisioning and to determine the cause of nest failure.

Collectively, the reproductive rate of osprey pairs in the main stem of the Bay was 0.55 young/pair, that was below the population maintenance level of 1.15. In comparison, reproductive rate within reference sites was 1.36 young/pair, that was above the maintenance target.



Based upon direct observations during nest visits, there was no question to osprey observers that the largest contributing factor to poor breeding performance was the loss of young due to starvation.

One of the best indicators of food stress in Chesapeake Bay ospreys is the frequency of single-chick broods in the population. Of all broods successfully produced within main stem study areas (N=152), more than half (53.3%) were single-chick broods. In contrast, only 18.2% of the 55 broods within reference study areas were single-chick broods. On average, main stem pairs lost 1.1 young between hatching and fledging compared to only 0.3 for pairs in reference sites. This subpopulation of osprey is underwater, demographically.

What is more, osprey observers noticed that a large number of osprey pairs did not lay clutches during the 2024 nesting season. These pairs arrived from wintering grounds in a timely manner (late Feb-early March) and defended their territories but they never laid eggs. This is the first time that this behavior has been documented on a large scale within the Bay. A likely explanation for the behavior is that females were not able to reach the adequate physiological body condition required to lay eggs. What we are seeing is a hollowing out of the population specific to the main stem of the Bay, and it was clear that ospreys in our water could not find menhaden to feed the young.

Please note that Omega Protein (<https://omegaprotein.com>) in Reedville VA is the ONLY commercial menhaden fishing Company in the State of VA. ALL other ASMFC member-States have already prohibited industrial menhaden fishery-- Thus, the Atlantic menhaden quota allocations of these states are very low (between 0.01% of the total in Pennsylvania to 11.0% in New Jersey), except for Virginia that gets a whopping 75.21% of menhaden quota allocations. And I like to repeat that Omega is the only commercial fishery company in Virginia, owned by Canada's Cooke Inc., and Omega uses most destructive purse seine fishing methods (to scoop up not only menhaden but also many bi-catches).

Against Virginia citizens' complaints, Omega has indicated that they have not fished in the Mobjack Bay area since 2000. But they state that their vessels work where the fish are; that they use spotter planes daily to determine where to fish; and then they send convoys of vessels to use purse seine fishing to catch menhaden.

I understand that the management board has already examined the USGS studies discussed during the August meeting. However, please do note that the USGS does not represent all that is known about the Bay osprey population. USGS did minimal (actual observation) fieldwork with osprey and they used breeding bird survey data (BBS) to examine regional trends. There are many other scientific data specific to ospreys. Please DO make sure to listen to other very reliable, scientific and osprey-specific studies compiled by scientists.

As precautionary measures, we osprey watchers sincerely and strongly request that the Atlantic Menhaden management board formalize restrictive rules and measures against menhaden reduction fishing in the Virginia/lower Bay waters in order to revive ospreys annual reproductive performances. For the sake of the osprey, we propose that there should be no fishing within the Chesapeake Bay from March 15 to August 15.

I can not see any compromise positions that would allow any fishing within 3 miles of the shoreline within the Bay during those months.

Sincerely yours

Tomoko Hamada, Ph.D.

Organizer

Osprey-Watch Alliance

[hamada.tomoko.sann@gmail.com](mailto:hamada.tomoko.sann@gmail.com)

CAUTION: This email originated from outside of the organization. Do not click links or open attachments unless you recognize the sender and know the content is safe.

## James Boyle

---

**From:** tomoko hamada <hamada.tomoko.san@gmail.com>  
**Sent:** Wednesday, September 18, 2024 4:47 PM  
**To:** John Clark; Caitlin Craig; Meghan Lapp; James Boyle  
**Subject:** [External] Response to Omega's claim re Menhaden issue

Dear Atlantic States Fisheries Management Board, Menhaden management board

As you may know Omega Protein is the only company that continues commercial purse-seine fishing of menhaden in the Virginia Water.

The company sent the comments re ospreys and menhaden to your board and the following response are given by Osprey scientist/expert.

Thank you

Tomoko Hamada, Ph.d.

Osprey-Watch Alliance

### RESPONSE TO OMEGA COMMENTS.

BY BRYAN WATTS

**COMMENT** - To put it charitably, the motion puts the proverbial horse before the cart, assuming that "further precautionary management" measures – *i.e.*, measures beyond the precautionary

Chesapeake Bay reduction fishery cap 51,000 metric tons ("mt") – are needed to protect

piscivorous birds and fish. There is no evidence, however, that the menhaden bait and reduction fisheries in the Bay are having any adverse impacts on avian or fish predators. Nor is it likely that the current menhaden fishery in the Chesapeake Bay is having adverse effects given that it is currently being prosecuted at some of the lowest levels in the past 150-plus years and the unitary, migratory menhaden stock is both highly abundant and conservatively managed.

**RESPONSE** – To the contrary, this assessment and consideration is overdue not premature. There has been evidence for at least 20 years that consumers in the Bay (osprey and striped bass as only 2 examples) that depend on menhaden as a primary food source have been impacted by low menhaden availability. The current level of harvest relative to historic harvest is not relevant to this issue. The famous collapse of the Pacific sardine stock is a prime example of this same pattern. When a stock is limited within a specific location you do not accelerate harvest you ease back on harvest to allow for recovery.

**COMMENT** - It is unclear what information the Working Group intends to base any recommendations upon. At the Summer Meeting, the Menhaden Board was presented with a detailed presentation by the U.S. Geological Survey ("USGS") on what is known, and not known, about the present state of local populations of osprey in the Chesapeake Bay region. The Board was informed that, overall, the regional osprey population increased 1,801% between 1966 and 2022. The USGS scientists noted that over a shorter timeframe – 2012-2022 – there had been a slight decline in their numbers within the mainstem of the Bay and its tributaries (though increased populations inland). That decrease appears to be more pronounced in the Maryland portion of the Bay, but it is a trend that has been seen all along the Atlantic Coast. (See Figure 1, below.)

**RESPONSE** – The USGS did not present all that is known about the Bay osprey population. USGS has done minimal fieldwork with osprey in the Bay. They used breeding bird survey data (BBS) to examine regional trends. This metric is based on point counts conducted by citizens and is a poor representation of the population. It is not really designed to examine fine-scale trends. Its use was not necessary in this case since we have population assessments for the Bay. Yes, it is true that the osprey population in the Bay has increased dramatically since the DDT era. As with virtually all osprey populations around the globe the Bay population declined by approximately 90% due to DDT. The population has recovered ten fold since the lows of the 1960s. We reached 3,500 pairs by 1995 and now are in the range of 10,000 pairs. However, we have seen dramatic spatial variation in recovery patterns. Pairs in lower salinity (<5 ppt) reaches have increased dramatically and this increase is continuing to

present. These lower salinity subpopulations are driving the Bay-wide recovery. Subpopulations around the main stem of the Bay are either stable or declining since the mid-1990s. See Watts et al. 2004 – Status and distribution of osprey in the Chesapeake Bay. We are now seeing a hollowing out of populations along the main stem. The main stem of the Chesapeake Bay was considered a global stronghold for osprey during the DDT era and was a key population that supported the restoration of osprey populations across many states. This historic population is now suffering from an inadequate prey base.

Osprey populations are not declining along the entire Atlantic Coast. Your figure is from e-bird data which reflects reports of detections from birders. These should not be confused with systematic or benchmark surveys. What is going on in the Bay should not be conflated with what is going on elsewhere. The patterns we are seeing in the main stem of the Bay are specific to the main stem of the Bay.

**COMMENT** - Importantly, the USGS does not know exactly what accounts for this trend. One of the scientists mentioned that it is not uncommon for recovering populations to increase levels past carrying capacity, though did not speculate that this is the cause of the general coastal decline in osprey populations. They did note likewise increasing trends for competitor species, such as bald eagles, cormorants, pelicans, gulls, etc. Competition can lead to intraspecific competition for nest sites and prey and depredation. Other things they identified include weather events which are becoming more frequent and severe with climate change, disease like the avian influenza epidemic currently underway, environmental contaminants, and water quality. None of these have been specifically implicated in the current decline in breeding success seen along the Atlantic coast.

**RESPONSE** – There is no documented general coastal decline in osprey. Yes, there are many ways for an osprey nest to fail and these have been documented widely. The facts in this case which have been presented in several different ways and are unequivocal demonstrate that poor breeding performance in the main stem of the Bay is due to brood reduction via starvation. We have shown this in the 40+ year retrospective (see Watts et al. 2024) that indicates 1) reproductive rates have gone from surplus to deficit during the 1990s, 2) this decline is due to an increase in brood reduction (chicks starving in the nest) and 3) the brood reduction is the result of reduced provisioning rates with menhaden. We later demonstrated this deficit by conducting a food supplementation study (Academia and Watts 2023) and showed definitively that increases in menhaden provisioning will drive productivity back to surplus. The issue here is that there is not enough menhaden available to osprey to support a viable breeding population within the main stem of the Bay. In 2024, we worked throughout the main stem of the Bay and showed that 1) none of the 10 study areas broke even demographically and 2) low reproductive rates were attributed to brood reduction via starvation. Let me be clear that the issue of 1) reproductive rates for osprey in the main stem of the Bay are below that required to sustain a population and 2) the driving factor for the poor reproductive performance is brood reduction via starvation is settled. The debate needs to move beyond this point.

The issue of food competition continues to be brought up in this discussion. Yes, it is true that a number of species that depend on fish within the Bay have recovered from DDT lows including osprey, bald eagle, great blue heron, brown pelican, double-crested cormorants and others. However, to suggest that food competition between these birds is driving the poor reproductive performance in osprey shows no understanding of the basic metabolic demands. It was shown in McLean and Byrd (1991) – (the diet of Chesapeake Bay ospreys and their impact on the local fishery) that consumption by osprey is trivial compared to harvest. Later modeling that I conducted in the 2000s showed that the entire bird community does not have the capacity to exert control on fish populations. All of the species combined represent a rounding error on both the commercial harvest and the estimated consumption by fish predators. The birds on their own do not have the capacity to undermine productivity. However, both the commercial harvest and the community of fish predators do.

**COMMENT** - The USGS team did indicate, however, that a study is currently underway to investigate historical and present-day availability of prey for osprey. Those results are expected at the end of 2025. It would be prudent to postpone any such management actions until that study is complete.

**RESPONSE** – The study that USGS is referring to is mine. The intent is to compile data from osprey monitoring efforts along the entire Atlantic Coast (dozens of efforts some of which date back several decades). This includes hundreds of thousands of nest checks. Once the data have been compiled, we would be in a position to relate population and demographic metrics for osprey to menhaden indices over time. The amount of effort expected to collect, compile and make the monitoring data usable is significant. To date, there has been no funding made available to support this work. Without funding this effort will not be completed by the end of 2025.

**COMMENT** - Beyond the lack of scientific information to inform any management action, another reason to avoid a narrow focus on the menhaden fisheries is that it is far from the only or even most important food source for osprey. USGS presented information that only in the large mid-Bay

region, where salinity is about 8-13 parts per million, do menhaden comprise a significant portion of ospreys' diet. And in that region, osprey are even more dependent on striped bass, an overfished population currently subject to a rebuilding program. In the southern portion of the Chesapeake Bay, where the reduction fishery is concentrated, menhaden comprise only about 24% of osprey diet, with spotted sea trout being the dominant forage fish.

**RESPONSE** – This statement is nonsensical. Ospreys nesting in waters of the Chesapeake Bay that are >10ppt (including all the way to the mouth) are menhaden-dependent. This is a very large swath of the Chesapeake and includes the lower reaches of major tributaries. Within these waters menhaden appear to be a keystone species. Historically, menhaden accounted for more than 70% of the diet and Chesapeake Bay osprey were considered from the 1960s to 1980s to be menhaden specialists. Osprey are not more dependent on striped bass which represents a minor diet component. The importance of menhaden in the diet since the 2000s has declined to below 30% and this is why we believe that productivity has declined. I have no idea where the comment comes from about dietary percentages in the lower Bay.

Globally and within the Chesapeake, osprey take a wide range of fish species. However, all of these species are not equal. I would ask why is it that Omega does not run the reduction operation on spot or trout? It is because these species do not have the same energy density (lipid content) and they do not school in the same way. The same is true for osprey. Osprey depend on the energy density and the schooling behavior of menhaden to break even. They do not do well with a diet dominated by species with low energy density.

**COMMENT** - If the primary factor in recent declines is lack of forage, then the Working Group should focus on the full suite of forage available to osprey, which, of course, are generalists when it comes to feeding. Indeed, it would be responsible to look at whether environmental factors, such as water temperature, salinity, and dissolved oxygen levels during breeding season may be influencing fish availability.

**RESPONSE** – Osprey are not generalists when it comes to feeding. As indicated above, menhaden are a keystone species for osprey and for other piscivores in the Bay. Their characteristics of high energy density and dense schooling make them unique in the Bay to predators.

**COMMENT** - There is only one study that purports to identify the menhaden fishery as the culprit in the lack of nesting success in one small portion of the Chesapeake Bay. That report, "[Food supplementation increases reproductive performance of ospreys on the lower Chesapeake Bay](#)," authored by master's candidate Michael H. Academia and Bryan D. Watts, director of the College of William & Mary's Center for Conservation Biology ("CCB"), focuses on observed low rates of reproductive success among osprey inhabiting Mobjack Bay, an area along the western side of the lower Chesapeake Bay. The study found that providing fish to nests improves survival of the young birds.

**RESPONSE** – This is not the only study focused on the issue. See Watts et al. 2024 that examines a range of reproductive metrics across more than 40 years and concludes that changes in menhaden abundance and the most likely explanation for shifts in reproductive rates, provisioning rates, brood reduction, nest failure, etc.

The food supplementation study shows that not only are supplemented nests more productive than control nests but reproductive rates were pushed above maintenance levels which has implications at the population level.

**COMMENT** - Going beyond the evidence, the authors conclude that the Chesapeake Bay menhaden fishery—specifically the reduction, and not the bait, fishery—could cause osprey populations to “decline precipitously, threaten population stability, and eventually lead to widespread population collapse.” They call for a return to the 1980s levels of menhaden in the Bay to be accomplished by further reducing or eliminating the reduction fishery's Bay harvest. These recommendations are not supported by the study's findings. In fact, as shown below, it is highly unlikely that the fishery has any impact on foraging issues facing osprey in this small area.

**RESPONSE** – As indicated above, the food stress experienced by osprey pairs and the resulting poor breeding performance extends throughout the main stem of the Bay and is not restricted to Mobjack Bay.

**COMMENT** - There is reason to suspect that foraging success by adult osprey in Mobjack Bay has declined based on CCB provisioning studies over the years. But nothing suggests that menhaden abundance is a cause. For example, compared to the last study in 2007, **menhaden comprised a higher percentage of fish delivered to nests in 2021**. So, while the amount of forage fish caught by or available to osprey (which are generalists when it comes prey) may be lower than years past, menhaden are *relatively* more abundant than other stocks compared to 2007.

**RESPONSE** – Everything in the patterns we have collected suggests that menhaden abundance is the cause of the lower provisioning rates and poor reproduction. Provisioning overall and with menhaden has declined dramatically. If you look at the energy content of the diet it has declined by 50% due to the lack of menhaden. The data we have indicates that the change in reproductive performance occurred during the 1990s and likely the late 1990s. If you don't believe the osprey in terms of menhaden declines in Mobjack Bay then listen to both the bait and reduction fisheries. During the partnership meeting in the summer of 2023, both Omega and the bait companies indicated that they used to fish for menhaden in Mobjack but have not since about 2000. Given that they are using spotter planes the clear implication is that there are now not enough menhaden in Mobjack to make it worth their while to fish there. Their own fishing behavior suggests that there has been a change in menhaden within Mobjack Bay.

**COMMENT** - Beyond that, overall menhaden biomass has been high for decades. In 2021, the year of the study, it was at its second highest level since 1961. Within the Chesapeake Bay, the menhaden young-of-the-year index for the two mid-Bay rivers, the Choptank and Patuxent, were at their highest and fifth highest levels in 2021, meaning there were abundant small menhaden in this region. For the Bay overall, recruitment of menhaden was the highest in the late 1970s and into the 1980s when environmental conditions were favorable and the striped bass population had crashed. As striped bass recovered menhaden recruitment declined, suggesting that osprey may be competing with that stock.

**RESPONSE** – Typical osprey fish size is 10-12 inches but will take smaller and larger fish. Most of the menhaden taken by osprey are likely in the year 2-4 classes. I do not know of any menhaden data that will help to resolve the spatial variation in menhaden abundance at the consumer level. If such data existed it would be a simple matter to relate osprey reproductive success at the subestuary level with menhaden abundance.

**COMMENT** - Finally, the Chesapeake Bay menhaden fishery is currently at its lowest sustained levels on record due to decreases in the Bay reduction fishery cap and actions by Omega Protein and Ocean Harvesters to reduce their Bay footprint and minimize user conflicts. Importantly, this fishery has been prosecuted in the Chesapeake Bay since the 1850s. For most of that time, menhaden removals from the Bay have been three or more times higher than currently. More importantly, the only reduction fishing that occurred during the study period in May 2021 when most nests failed was north of Mobjack Bay and thus had no impact on that area.

**RESPONSE** – These comments are reminiscent of those made during the 1940s before the loss of the Pacific sardine fishery. The gross take is not the issue but rather the take relative to what the stock can sustain. Since we have no independent data on the abundance of menhaden in the Bay, we have no way of independently assessing if the current take is sustainable. Omega is the only entity that has the data to evaluate trends in menhaden over time. Release the flight logs and the catch data so that we can evaluate the trend in catch per unit search over time. Since this is the only dataset capable of resolving trends over time, without using it we will continue to twist in the wind and have unproductive debates.

**COMMENT** - The researchers never asked why there are fewer forage fish of all types in Mobjack Bay, such as whether its environmental conditions have become less favorable. Given that osprey are declining all along the east coast, it appears broader forces are at work.

**RESPONSE** – I have been asking about fisheries data since the early 2000s. It is clear that the fisheries data is inadequate to address the questions. This is why in 2021 we did a supplementation study. If the menhaden data were available at a scale that is relevant to the consumer it would have been a simple matter to relate the two. There is no indication that osprey are declining along the entire south Atlantic. I would say that along the Atlantic north of the Chesapeake where menhaden have shown recent recovery, osprey are producing very well.

**COMMENT** - The timing and location of the menhaden fishery do not suggest that it could have had an impact on the availability of menhaden in Mobjack Bay. At the recent meeting of the Ecological Reference Point Working Group meeting, Dr. Watts indicated that the highest number of nest failures in 2021 occurred in May. However, that month, none of Ocean Harvester's vessels made all of its sets above the study area, indicating that

menhaden had entered the Bay, but apparently did not choose to enter Mobjack Bay in significant numbers. Likewise in June, no sets were made anywhere near the nesting sites.

**RESPONSE** – To suggest that the only way that harvest can impact the distribution and availability of fish is when the fleet is removing them is far too limited a perspective. It is hard to know how repeated harvest over a long time period will influence distribution. In terms of water quality, development pressures, etc. may have on menhaden in Mobjack we will never know since the menhaden data do not exist. However, poor performance across the 10 study areas monitored in 2024 which vary in many respects suggest that this is not solely a localized cause. One of the more interesting findings in 2024 was that Lynnhaven River and Eastern Shore study areas did marginally better than the other sites. These two areas are near where Omega operated during the year which may indicate that menhaden were more available in those areas. Again, we have no direct menhaden data.

**COMMENT** - It is important to keep in perspective the current levels of menhaden fishing effort in the Chesapeake Bay. Due both to management action (the Bay Reduction Cap) and efforts by Ocean Harvesters to minimize its footprint in this estuary, current harvest levels are about a third of those during the 1980s when the first big osprey feeding habits study was conducted. It is also worth bearing mind that this fishery has been in operation since the mid-1800s and over most of that time, the reduction fishery in the Chesapeake Bay and coast-wide landed far more menhaden than it does today.

**RESPONSE** – There is no question that menhaden abundance was adequate to support osprey during the 1980s. Again, the gross take is not the issue but rather the take relative to what the stock can sustain. Since we have no independent data on the abundance of menhaden in the Bay, we have no way of independently assessing if the current take is sustainable. Omega is the only entity that has the data to evaluate trends in menhaden over time. Release the flight logs and the catch data so that we can evaluate the trend in catch per unit search over time. Since this is the only dataset capable of resolving trends over time, without using it we will continue to twist in the wind and have unproductive debates.

**COMMENT** - The Chesapeake Bay Working Group has been given a task greater in difficulty than that of the Ecological Reference Point Working Group. Specifically, it has been asked to determine the needs of all predatory fish and birds at each life-stage and time of the year, and then to develop a highly calibrated system of time/area closures and catch levels throughout the Chesapeake Bay such that the “need” for menhaden among the full suite of predators is fully met.

**RESPONSE** – This is not my understanding of the charge of the working group.

**COMMENT** - Any pretense of an impartial, science-driven process would be informed by basic information that is simply not available. These include: dietary demands of all predators in the region relative to the time-varying amount of migratory menhaden within the Bay and biomass of all other prey species; the impact on populations of interest (*e.g.*, osprey, striped bass) of competition not only among avian predators, or among species of predatory fish, but of competition between birds, fish, terrestrial and marine mammals, etc., and humans for a fixed set of resources in specific locations and times of the year; and, of course, a basic understanding of the patterns of movement of menhaden and other prey species within the Chesapeake Bay throughout the year, along with the environmental factors favoring or disfavoring their abundance in a particular area.

**RESPONSE** – I would argue that policy related to harvest has never been science-driven. Aside from the ecosystem issues, how are you able to evaluate impacts of harvest levels on the stock itself without an independent measure of the Chesapeake Bay stock and a reasoned assessment of risk to the stock which we have never had. The answer is you can't. In lieu of such an independent assessment, you have set harvest limits based on the past five years of harvest. I don't believe that meets anyone's definition of science-driven. In short, decisions about harvest have been based on political influence rather than biological data.

**CAUTION:** This email originated from outside of the organization. Do not click links or open attachments unless you recognize the sender and know the content is safe.

## James Boyle

---

**From:** Dylan Joyner <joynerde@gmail.com>  
**Sent:** Wednesday, September 25, 2024 11:12 AM  
**To:** Comments  
**Subject:** [External] ASMFC atlantic menhaden work group

Please help impose fishing regulations in the lower chesapeake bay! The fishing and wild life are suffering due to the drastic over fishing of menhaden by the omega protein company out of reeds reedsville VA.

R,  
Dylan Joyner

CAUTION: This email originated from outside of the organization. Do not click links or open attachments unless you recognize the sender and know the content is safe.



## James Boyle

---

**From:** Jake Monahan <monahanjake3@gmail.com>  
**Sent:** Wednesday, September 25, 2024 10:56 AM  
**To:** Comments  
**Subject:** [External] ASMFC Atlantic Menhaden Work Group

Commercial fishermen and their families are essential to a healthy economy and restaurants.....OMEGA Factories floating around strip mining our oceans taking product that small business owners need is a CRIME

***Jake***

CAUTION: This email originated from outside of the organization. Do not click links or open attachments unless you recognize the sender and know the content is safe.

## James Boyle

---

**From:** Ellen Stromdahl <ellen.stromdahl@gmail.com>  
**Sent:** Tuesday, September 17, 2024 8:32 PM  
**To:** Comments  
**Subject:** [External] Pungoteague creek

Hello,

We have been fishing Pungoteague Creek for nearly 20 years and have noticed a big decline in numbers of fish and size of species (croaker, kingfish, spot). Nowadays these once abundant species rarely measure more than 7". Ten years ago we could catch 30-40 big (12 - 14" long) of these fish on a good day - summer after summer.

Stop the menhaden removal and let's see if these species rebound.

Ellen Stromdahl

Harborton 23389

Sent from my iPhone

CAUTION: This email originated from outside of the organization. Do not click links or open attachments unless you recognize the sender and know the content is safe.

## James Boyle

---

**From:** jtefankjia <jtefankjia@aol.com>  
**Sent:** Wednesday, September 25, 2024 11:24 AM  
**To:** Comments  
**Subject:** [External] ASMFC Atlantic Menhaden work group

I am a 65 yr old NJ fisherman and enviornmentalist, Fished the Atlantic City/ Brigantine waters all.my life, I've participated in fish and Osprey surveys and tagging , I also build and install Osprey Nesting platforms, I monitor the arrival , feeding, nest building , egg laying, incubation and feeding habits , I also observe the chicks development feeding and fledging.. As a young man I remember Adult Menhaden schools the size of football fields in our bays and Oceans ! In March huge adult bunker would come in and lay their eggs, They would be "popping" everywhere! Now barely any adult bunker come in during the spring , hence a shortage of any Menhaden. I also volunteer with Ben Wurst to help with the NJ Osprey Project! Even Ben has recognized the absence of the main food source Menhaden! We have had consecutive years of very poor Osprey fledglings, Many young birds are perishing due to lack of Menhaden from the Chesapeake to New York, pretty coincidental that the Menhaden Reduction fleet and failing Osprey nests are in the same areas, Whales, Dolphins, Seals, Striped Bass all depend on Menhaden for survival.. Did you know the Ospreys get their hydration from the Menhaden they consume, So lack of bunker not only causes starvation but dehydration as well.. Many Osprey fly further to find their favorite food leaving nests for long period of time, many Ospreys have gone missing looking for food leaving a starving female with starving chick's.. Striped Bass follow the Menhaden schools during migration, the absence of the once large schools has caused a reduction in Striped Bass population as well as Dolphins, Whales, Seals, Bluefish, Tuna, Gannets etc.. Menhaden is one of the primary food sources for all sea creatures, This practice of harvesting Menhaden must stop before more species already struggling gets much worse.. We closed down Striped Bass and they rebounded let's do the same with Menhaden.. ASMFC let's make an intelligent decision based on facts , NOT POLITICAL OR DOLLARS! THANK YOU FOR YOUR TIME JOHN TEFANKJIAN

Sent from my Verizon, Samsung Galaxy smartphone

CAUTION: This email originated from outside of the organization. Do not click links or open attachments unless you recognize the sender and know the content is safe.

## James Boyle

---

**From:** Phil Zalesak <[smrfo2021@gmail.com](mailto:smrfo2021@gmail.com)>  
**Sent:** Thursday, October 3, 2024 9:26 AM  
**To:** James Boyle  
**Cc:** Marty Gary; Philip Zalesak  
**Subject:** [External] Fwd: MENHADEN WORK GROUP PROBLEM STATEMENT  
**Attachments:** 2024-0916 Menhaden Working Group Comments.pdf

----- Forwarded message -----

From: **Phil Zalesak** <[smrfo2021@gmail.com](mailto:smrfo2021@gmail.com)>  
Date: Wed, Oct 2, 2024, 12:23 PM  
Subject: MENHADEN WORK GROUP PROBLEM STATEMENT  
To: SPUD WOODWARD <[SWOODWARD1957@gmail.com](mailto:SWOODWARD1957@gmail.com)>, ALLISON COLDEN <[acolden@cbf.org](mailto:acolden@cbf.org)>  
Cc: Philip Zalesak <[flypax@md.metrocast.net](mailto:flypax@md.metrocast.net)>, Phil Zalesak <[smrfo2021@gmail.com](mailto:smrfo2021@gmail.com)>

Spud / Allison,

Here's a problem statement based on previous work done for the ASMFC in 2009. It is concise and encompasses the problem - "Localized depletion of Atlantic menhaden is occurring in the Chesapeake Bay." See reference (a) and the enclosure.

The Fishery Subgroup can get all the data they need from Ray Mrock regarding menhaden purse seine harvest in the Chesapeake Bay on a monthly and annual basis. All they have to do is call him. This is the most critical data set.

The Osprey Subgroup can get peer reviewed publications from Dr. Bryan Watts.

Forwarded for your review and consideration.

Take care, Phil

### Reference

(a) [Report on the evaluation \(noaa.gov\)](#) - "Localized depletion in the Chesapeake Bay is defined as a reduction in menhaden population size or density below the level of abundance that is sufficient to maintain its basic ecological (e.g. forage base, grazer of plankton), economic and social/cultural functions. It can occur as a result of fishing pressure, environmental conditions, and predation pressures on a limited spatial and temporal scale."

CAUTION: This email originated from outside of the organization. Do not click links or open attachments unless you recognize the sender and know the content is safe.

**From:** [Tom Lilly](#)  
**To:** [Tina Berger](#); [Comments](#)  
**Subject:** [External] Fw: comments to menhaden board  
**Date:** Tuesday, October 8, 2024 9:47:00 AM  
**Attachments:** [Two on Page Landing data.pdf](#)  
[Virginia Southwick data.pdf](#)  
[Frontiers 2021 and pg 12.pdf](#)

---

Tina please acknowledge one more time ...this is for the board and James Tom

James, Martin, Spud, Allison and Bob,

What happens next in menhaden management is very important to me, my family and friends that have seen the disappearance of our striped bass and the starvation of our ospreys as the menhaden have quit coming to the Wicomico River where I live a short distance from the Virginia line. It's very hard to stay here anymore looking out on the river every day knowing I have failed in my best efforts to protect this wildlife that meant so much to us.

We thought this would change for the better when the Commission adopted the ERP science in 2020 and said striped bass were the "canary in the coal mine" as to menhaden harvests, but, sadly, we now know that the interests of one foreign owned fishing company in Virginia, is much more important to the menhaden board than the ecology of Chesapeake bay and millions of people and their children that would benefit if that intense wasteful fishing stopped in Virginia waters.

That said, will you please advise what recommendations the work group will be making to the board on October 22 ? Will the board have access to the total landing by the factory fishing in the bay for 2023 and the monthly landings for the bay for this season to see if the disturbing trends discussed in the mail below are continuing? Will they recommend moving the factory fishing out of Virginia waters? Will they take steps to protect the small amount of menhaden migrating to the bay in the spring to rebuild the forage base? Will they take steps to prevent the factory from catching 1,000s of menhaden schools just before they migrate to Maryland to feed our wildlife? Will they prevent the factory from catching the schools migrating from Maryland in the fall to the Atlantic that would have become the bay's future breeding stock ? Moving the factory fishing into the US Atlantic would accomplish all these goals.

Thank you for a prompt reply so we can pass this on the supporting groups listed in note 2 of the below mail in time for them to make their own comments to the board (send to [comments@asmfc.org](mailto:comments@asmfc.org) attn

menhaden board, J. Boyle) prior to the deadline of 10 am Friday October 18th. Tom Lilly Whitehaven , MD

----- Forwarded Message -----

**From:** Tom Lilly <foragematters@aol.com>

**To:** comments@asmfc.org <comments@asmfc.org>; Tina Berger <tberger@asmfc.org>

**Sent:** Tuesday, September 24, 2024 at 04:08:27 PM EDT

**Subject:** comments to menhaden work group

To the work group ( Tina can you once again confirm receipt?)

#### DECLINE IN SPRING MENHADEN IN BAY

From the monthly catch charts (n.1) (scan) for 2017-2023 there is much less menhaden in the bay in the spring. The end of May totals are a strong proxy for what was there in March and April when our striped bass spawning stock and ospreys need it the most. There is no limit on what eight purse seiners can catch of the little bit coming in. The cause of this decline is debatable but whatever the cause isn't it more important than ever to fully protect what is coming in and what's there? That can be done by closing the season entirely until say June 15th to allow menhaden to migrate to safety to Maryland and moving the factory fishing into the US Atlantic zone to protect the bay's forage base.

#### PROTECTING THE MARYLAND SPAWNING STOCK

Please note the uptick in catching that consistently starts around mid September until end October. (n.1) Is this increase in fish coming mainly from schools that are migrating out of Maryland and the Potomac river on their way to the Atlantic wintering grounds to become the new spawning stock in spring 2026? Don't these fish have it in their genes to return to the bay but they are getting caught? They are being caught in the thousands of schools before they spawn the first time. Those fish migrating from and then back to Maryland would be largely protected by moving the factory and bait purse seining into the US Atlantic a reasonable distance from

the bay entrance. In a few years time that could lead to a much larger and more age diverse breeding stock to benefit the bay. This would also solve other bay problems of bycatch, toxic bilge discharges and net snags fouling beaches.

#### WHO SUPPORTS CHANGE

The people that care about the bay ecology and want to enjoy it with their families, friends, children and grandchildren and the organizations they support have done about everything possible in the last fifteen years or so to convince this board and the MRC to take decisive action (n.2) .

#### BAY STUDIES AND EXPERT ADVICE

In 2004 Chesapeake Bay fish and wildlife were in such poor condition that the menhaden board began looking at menhaden depletion issues. After five years with no action the board turned to a consultant, Dr. Maguire, for advice. In 2009 he said further research wasn't necessary, that time and area controls could be used to mitigate the factory fishing and avoid the "negative consequences" of inaction.(n.3) All of the states but Maryland and Virginia followed his advice and moved the factory fishing to the US Atlantic Zone. Maryland is the only state that cannot protect its bays, in this case Chesapeake Bay , from factory fishing because Maryland alone can't control what happens in Virginia so thousands of menhaden schools are being caught in VA near the Maryland line just before they get into Maryland to feed our wild life. The menhaden board did not follow Dr. Maguire's advice on Chesapeake bay and Virginia and the factory fishing continued. That was fifteen years ago and counting.

#### CONSEQUENCES NO SUCH THING AS A FREE LUNCH

The resulting decline in striped bass recreational fishing and its economic impact in Virginia was measured from 2009-2016 by Southwick Associates (n.4) The data shows that in Virginia striped bass trips declined annually from over a million in 2009 to less than half that by 2016 . So a half million trips with family, friends and children and all the physical and mental benefits that this nature based recreation would have provided ( especially for children) was lost. (n.5) The economic losses were staggering. By 2016 economic impact from striped bass trip expenses had fallen annually in Virginia to \$106 million

from \$240 million in 2009 and related jobs had declined from 3,583 to 1,444 by 2016. Two thousand jobs lost. We expect current Va information if available will continue these trends. Because recreational fishing in Maryland has declined 70% in the last ten years it is expected the current Maryland data would show the same scale of losses. What is the social and cultural impact of hundreds of charter captains leaving the business in both states ? What is the dollar loss when thousands of baby ospreys starve in the nest and the whales and bluefin tuna are disappearing ? We are told that NOAA values the landings of menhaden in Reedville at about 36 million dollars a year. Under the ERP science there is a direct connection between menhaden harvests and the well being of our striped bass stocks and ospreys.(n.6) So can an argument be made that when Virginia ( and the Commission) "gave" the factory fishing 90 % of the Virginia quota worth 36 million dollars a year the economic cost to Virginians in 2016 was at least \$140 million in lost income for businesses and the loss of over two thousand jobs? And what is the dollar value of Virginian's missing out on 500 thousand striped bass fishing trips a year? Fifty dollars a trip? A hundred? for a parent, friend or grandparent Priceless? There are hundreds of thousands of people in the two states involved with groups concerned with wildlife welfare.(n.2) What is the dollar cost to these people when they see bay wildlife suffering ? What is the value of their loss of enjoyment of bay resources? What is the cost in quality of life lost when millions of people in the two states see the very culture of the bay slipping away?

So there is no free lunch....someone always pays and it is the Chesapeake Bay ecology and the people of Maryland and Virginia that are paying a very high price when the factory fishing takes something approaching a hundred thousand tons of menhaden from the bay and approaching the bay a year and exports all that resource and profits to Canada. The people pay for it in their loss of business income, loss of jobs and most important in the loss of use and enjoyment of Chesapeake Bay.

In conclusion, we urge you to weigh the consequences of



leaving the factory fishing in Virginia "as is" compared to requiring that company that has received and is receiving hundreds of millions of dollars worth of resources that belonged to the people to do its future fishing in the US Atlantic zone during the times you judge best in your exercise of protective management for Chesapeake Bay.

Thank you for listening Tom Lilly

PS will the group chair or James Boyle please ask Ray Mroch at Beaufort Lab for the total factory landings in Chesapeake Bay for this season to see if the factory was able to catch the quota? Will they also ask for the weekly bay landings for this May and June to see if the trends for less and less menhaden continued in 2024. From what was observed there were many days they did not fish in the bay or ocean this season there were so few fish. Although confidential all that data is available to a menhaden board member or ASMFC staff on request according to the latest agreement between the industry and NOAA. Please request it.

NOTES;

(n.1) scan of charts below

(n.2) Theodore Roosevelt Conservation Partnership, Sierra Club Maryland ( 85,000 members) Virginia and National Audubon Society( 1.6 million members), Southern Md Audubon, Virginia Salt Water Fishing Assoc.- VSSA, CCA, American Sport fishing Association, National Marine Mfgs Assoc, Marine Retailers Assoc of the Americas, International Game Fish Assoc, Guy Harvey Ocean Foundation. Izaak Walton Foundation, Virginia Anglers Assoc., and seven other Virginia fishing groups, Southern Md Recreational Fishing Org., SMRFO, Maryland Saltwater Fishing Assoc., Center for Conservation Biology.. William and Mary and many other osprey groups, Maryland Charter Captains and Watermen, Northampton County Virginia Board of Supervisors , Delaware-Maryland Synod of the Lutheran Church, Blue Water Baltimore, Virginia Aquarium and Science Center, Chesapeake Legal Alliance, Audubon Societies of Northern Virginia and Richmond ( 5,000 members) , The 30 senators and delegates of the Maryland Legislative Sportsmen's Caucus collectively representing over a million Marylanders . Sierra Club of Virginia ( 5,000

members) , St Marys (Md) River Watershed Assoc ( 92 members) numerous other MD fishing groups, Save our Menhaden Coalition..... Endorsements on request  
(n.3) From the letter to Secretary Ross from Bob Beal dated November 15,2019 copy on request  
(n.4) From " Economic Contributions of Recreational and Commercial Striped Bass fishing" Southwick 2018 (scan)  
(n.5) References on request  
(n.6) See ASMFC ERP Press Release , For osprey as ERP indicator species for menhaden harvests and for inclusion in MICE model etc see journal article "The Path to an Ecosystem Approach to Forage Fish Management. Frontiers...May 2021 page 11 (scan) by 30 menhaden scientists from the MRC, ASMFC, Chesapeake Biological Lab, MD DNR and VIMS etc (scan)

**CAUTION: This email originated from outside of the organization. Do not click links or open attachments unless you recognize the sender and know the content is safe.**

Monthly Chesapeake Bay /Atlantic Landings from the NOAA Review of the 2017 Fishing Season  
NOAA Beaufort Lab

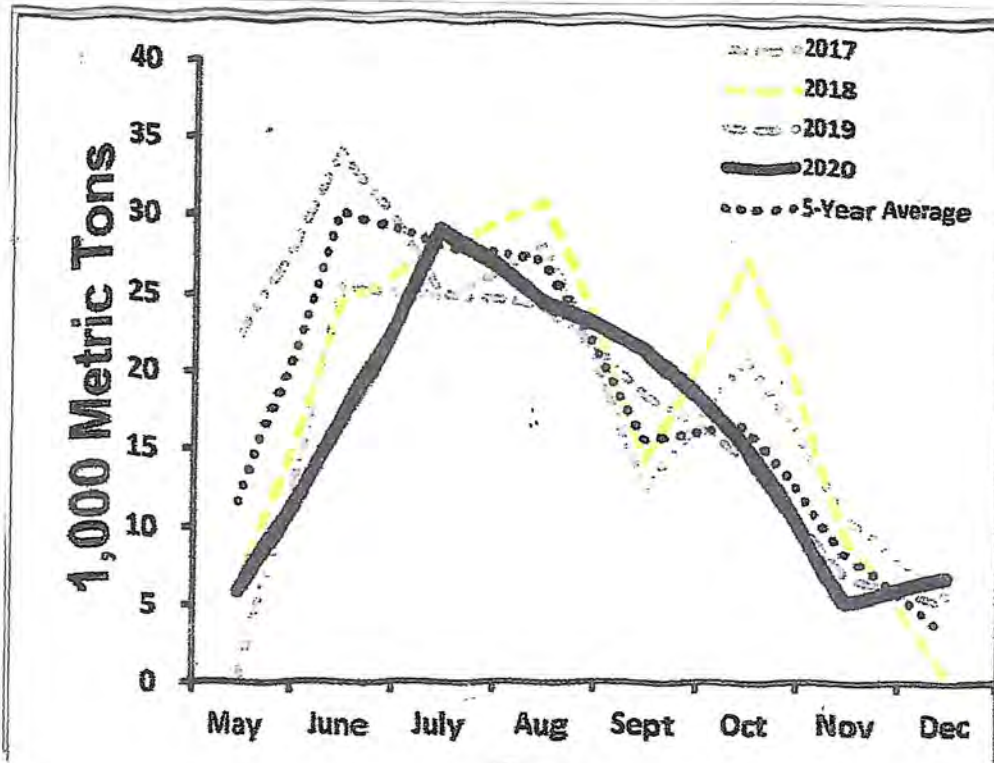
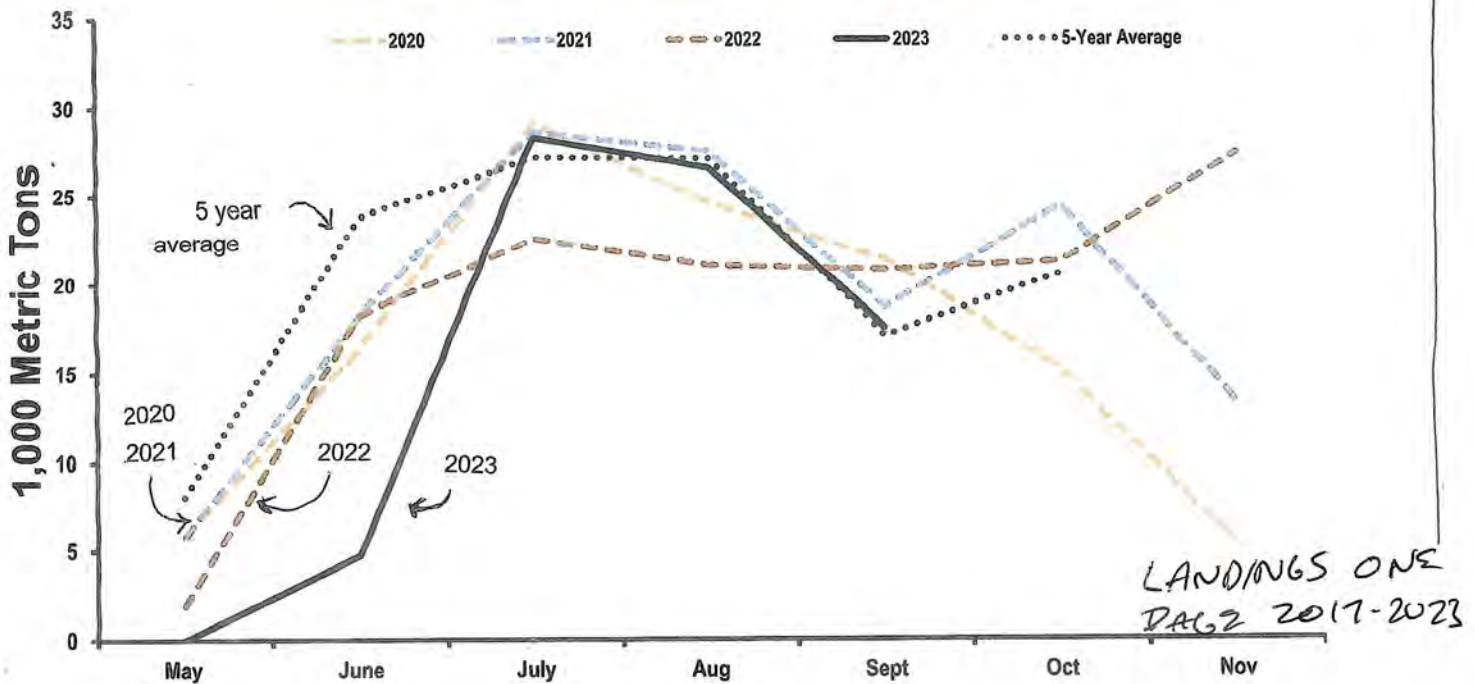


Figure 4. Atlantic Menhaden landings by month, 2017-2020.

Monthly Chesapeake Bay/ Atlantic Landings from the NOAA Review of the 2020 Fishing Season NOAA Beaufort Lab\*

**Reduction Landings by Month**



# **The Economic Contributions of Recreational and Commercial Striped Bass Fishing**

---

Produced for:

**The McGraw Center for Conservation Leadership**



**SOUTHWICK  
ASSOCIATES**

Revised April 12, 2019

PO Box 6435 ■ Fernandina Beach, FL 32035 ■ Office (904) 277-9765

# Virginia

## Participation

In 2016 and 2009, over 724,000 and over 907,000 anglers fished in Virginia, respectively. In each year, the average angler participated in around 10 fishing trips, of which a moderate portion was striped bass trips.

Table VA-1. Anglers and angler trips in Virginia

	2009	2016
Total Anglers	907,422	724,276
Total Trips	8,410,827	7,247,361
Striped Bass Trips	1,192,172	436,169
Bass Trips % of total	14%	6%

Table VA-2. Trip distribution by type in Virginia

	2009	2016
For-Hire	4%	4%
Private	79%	68%
Shore	18%	28%

## Spending & Revenues

For Virginia, total landings and their associated expenditures are presented below. We caution about using spending and revenues to make statements about the economic impacts created by the recreational and commercial fisheries, however. The multiplier effects for a dollar associated with each fishery are markedly different. A better approach is to examine each fishery's economic impacts which are in the next section.

Table VA-3. Sales and spending attributed to striped bass fishing in Virginia

	2009	2016
Commercial Landings (lbs)	2,108,685	1,333,572
Commercial Revenue (\$000s)	\$4,219.4	\$4,968.3
Recreational Landings (lbs)	5,387,784	1,024,378
Recreational Spending (\$000s)	\$249,746.5	\$108,002.9
Trip Spending (\$000s)	\$64,330.4	\$22,552.0
Durable Goods (\$000s)	\$185,416.0	\$85,450.7

### Recreational Economic Impacts

In 2016, \$106.6 million was added to the gross domestic product of Virginia, compared to just over \$240.5 million in 2009. There were 1,444 jobs supported in 2016 and 3,582 jobs supported in 2009.

Table VA-4. 2009 Economic impacts from spending related to recreational striped bass angling in Virginia

	Jobs	Salaries and Wages (\$000s)	GDP (\$000s)	Total Output (\$000s)	State/Local Taxes (\$000s)	Federal Taxes (\$000s)
Direct Effect	2,362	\$95,282.9	\$142,119.2	\$210,982.3	\$19,266.9	\$22,408.3
Multiplier Effect	1,220	\$56,634.5	\$98,401.3	\$171,009.9	\$8,227.7	\$14,301.0
<b>Total</b>	<b>3,582</b>	<b>\$151,917.4</b>	<b>\$240,520.4</b>	<b>\$381,992.2</b>	<b>\$27,494.6</b>	<b>\$36,711.2</b>

Table VA-5. 2016 Economic impacts from spending related to recreational striped bass angling in Virginia

	Jobs	Salaries and Wages (\$000s)	GDP (\$000s)	Total Output (\$000s)	State/Local Taxes (\$000s)	Federal Taxes (\$000s)
Direct Effect	959	\$42,451.4	\$62,924.8	\$90,355.4	\$8,623.6	\$10,016.5
Multiplier Effect	485	\$25,099.3	\$43,698.4	\$75,556.7	\$3,624.1	\$6,350.9
<b>Total</b>	<b>1,444</b>	<b>\$67,550.7</b>	<b>\$106,623.3</b>	<b>\$165,912.0</b>	<b>\$12,247.6</b>	<b>\$16,367.5</b>



Introduction

Assessment

and

Management

History

Current

Management

Challenges

and Future

Work

Lessons

Learned

Author

Contributions

Funding

Conflict of Interest

References

# The Path to an Ecosystem Approach for Forage Fish Management: A Case Study of Atlantic Menhaden

Kristen A. Anstead (<https://www.frontiersin.org/people/u/1089781>)<sup>1\*</sup>, Katie Drey (<https://www.frontiersin.org/people/u/990320>)<sup>1</sup>, David Chagaris (<https://www.frontiersin.org/people/u/495125>)<sup>2</sup>, Amy MeSchueller (<https://www.frontiersin.org/people/u/1119106>)<sup>4</sup>, Jason E. McNamee (<https://www.frontiersin.org/people/u/1124192>)<sup>5</sup>, Andre Buchheister (<https://www.frontiersin.org/people/u/1120381>)<sup>6</sup>, Geneviève Nesslage (<https://www.frontiersin.org/people/u/1126723>)<sup>7</sup>, Jim H. Uphoff Jr. (<https://www.frontiersin.org/people/u/1171712>)<sup>8</sup>, Michael J. Wilberg (<https://www.frontiersin.org/people/u/344791>)<sup>7</sup>, Alexei Sharov<sup>9</sup>, Micah J. Dean<sup>10</sup>, Jeffrey Brust<sup>11</sup>, Michael Celestino<sup>11</sup>, Shanna Madsen<sup>12</sup>, Sarah Murray (<https://www.frontiersin.org/people/u/1096785>)<sup>1</sup>, Max Appelman<sup>1</sup>, Joseph C. Ballenger (<https://www.frontiersin.org/people/u/1146004>)<sup>13</sup>, Udana Bhat (<https://www.frontiersin.org/people/u/359070>)<sup>2,14</sup>, Ellen Cosby<sup>15</sup>, Caitlin Craig<sup>16</sup>, Corrin Flora<sup>17</sup>, Kurt Gottschall<sup>18</sup>, Robert J. Latour (<https://www.frontiersin.org/people/u/1146038>)<sup>19</sup>, Eddie Leonard<sup>20</sup>, Ray Mroch<sup>4</sup>, Josh Newhard (<https://www.frontiersin.org/people/u/1111904>)<sup>21</sup>, Derek Orner<sup>22</sup>, Chris Swanson<sup>23</sup>, Jeff Tinsman<sup>24</sup>, Edward D. Houde (<https://www.frontiersin.org/people/u/615796>)<sup>7</sup>, Thomas J. Miller<sup>7</sup> and Howard Townsend (<https://www.frontiersin.org/people/u/530527>)<sup>25</sup>

*aiolden?*  
*spely?*

*leghs*  
*not clear*

- <sup>1</sup>Atlantic States Marine Fisheries Commission, Arlington, VA, United States
- <sup>2</sup>Nature Coast Biological Station, Institute of Food and Agricultural Sciences, University of Florida, Gainesville, FL, United States
- <sup>3</sup>Maine Department of Natural Resources, Boothbay Harbor, ME, United States
- <sup>4</sup>NOAA Fisheries, Beaufort, NC, United States
- <sup>5</sup>Rhode Island Department of Environmental Management, Providence, RI, United States
- <sup>6</sup>Department of Fisheries Biology, Humboldt State University, Arcata, CA, United States
- <sup>7</sup>Chesapeake Biological Laboratory, University of Maryland Center for Environmental Science, Solomons, MD, United States
- <sup>8</sup>Cooperative Oxford Lab, Maryland Department of Natural Resources, Oxford, MD, United States
- <sup>9</sup>Maryland Department of Natural Resources, Annapolis, MD, United States
- <sup>10</sup>Massachusetts Division of Marine Fisheries, Gloucester, MA, United States
- <sup>11</sup>New Jersey Division of Marine Fisheries, Port Republic, NJ, United States
- <sup>12</sup>Virginia Marine Resources Commission, Hampton, VA, United States
- <sup>13</sup>South Carolina Department of Natural Resources, Charleston, SC, United States
- <sup>14</sup>OKEANOS Research Center, University of the Azores, Horta, Portugal
- <sup>15</sup>Potomac River Fisheries Commission, Colonial Beach, VA, United States
- <sup>16</sup>New York Department of Environmental Conservation, East Setauket, NY, United States

192

*The 3*

*18*

*10*

from BAM. All focal species had recently undergone single-species stock assessments, which provided life history, landings, and index data through 2017, as well as estimates of fishing mortality and population size. Newer data were not available for all of the groups included in the full NWACS EwE model; as a result, inputs for those groups were extrapolated from the terminal year of 2013.

The ERP WG evaluated the five ERP models based on their performance (i.e., residuals, sensitivities, and other diagnostics), their strengths and weaknesses, and their ability to inform the fundamental ecosystem management objectives (Buchheister et al., 2017a,b; McNamee, 2018; Uphoff and Sharov, 2018; Nesslage and Wilberg, 2019; Chagaris et al., 2020). The ERP WG ultimately recommended using the NWACS-MICE model rather than the other four for two reasons. First, the EwE framework used by the NWACS-MICE model was the only approach that could address both the top-down effects of predation on Atlantic menhaden and the bottom-up effects of Atlantic menhaden on predator populations, which were required to evaluate the key tradeoffs between Atlantic menhaden harvest and predator needs that were central to the identified ecosystem objectives. Second, the NWACS-MICE implementation was less data-intensive than the full NWACS model, which reduced some of the uncertainty associated with modeling the data-poor predators and prey in the full model. This meant the NWACS-MICE model could be updated more quickly and efficiently, on a timeframe that met manager's needs. Comparisons of the full and MICE versions of the NWACS model indicated that the NWACS-MICE model included the fish predators most sensitive to the menhaden population. Striped bass was the most sensitive fish predator to Atlantic menhaden harvest in both models. In the full NWACS model, nearshore piscivorous birds were also sensitive to Atlantic menhaden  $F$ , but their response was similar to striped bass over the range of scenarios explored by the full model (Southeast Data Assessment and Review [SEDAR], 2020b). This choice was consistent with a growing body of literature that has recommended models of intermediate complexity (i.e., MICE) for ecosystems as representing a compromise between complexity/realism and uncertainty for use in management (Plagányi et al., 2014; Collie et al., 2016; Punt et al., 2016). Specifically, the ERP WG recommended using the NWACS-MICE in conjunction with the single-species assessment model, BAM; the NWACS-MICE model would provide strategic advice about the trade-offs between Atlantic menhaden fishing mortality and predator biomass to set reference points, while the single-species model would be used to provide short-term tactical advice about harvest strategies to achieve the ERP  $F$  target (Chagaris et al., 2020; Southeast Data Assessment and Review [SEDAR], 2020b). The ERP report was peer-reviewed with the single-species assessment in 2019, and the ERP WG's recommended tool was deemed acceptable for management use by a panel of independent experts (Southeast Data Assessment and Review [SEDAR], 2020b). The peer-review panel also recommended the continued development of the alternative models going forward.

## Current Management

The development and implementation of ERPs for Atlantic menhaden was a lengthy process (Figure 4 and Table 1), but in August 2020, ASMFC adopted the approach from the ERP WG for management use. The ERP target was defined as the maximum  $F$  on Atlantic menhaden that would sustain striped bass at their biomass target when striped bass were fished at their  $F$  target. The ERP threshold was defined as the maximum  $F$  on Atlantic menhaden that would keep striped bass at its biomass threshold when striped bass was fished at its  $F$  target. For both reference points, all other species in the model were fished at their *status quo* (i.e., 2017)  $F$  rates. Striped bass was the focal predator species for this analysis because it was the most sensitive to Atlantic menhaden  $F$  in both the NWACS-MICE and the full NWACS models. Thus, levels of Atlantic menhaden  $F$  that sustain striped bass should also sustain piscivorous birds and less sensitive predators, in the absence of significant disruptions to the ecosystem (Southeast Data Assessment and Review [SEDAR], 2020b). With these ERP targets and thresholds, the Atlantic Menhaden Management Board reviewed projections from the single-species model, BAM, and set a quota for 2021 and 2022 of 194,400 mt, a 10% decrease in the quota from 2020.

FIGURE 4



## James Boyle

---

**From:** Joanie Millward <virginiaospreyfoundation@gmail.com>  
**Sent:** Monday, September 2, 2024 3:23 PM  
**To:** James Boyle; FW.Marine@dec.ny.gov  
**Subject:** [External] Ospreys in Colonial Beach, Virginia  
**Attachments:** Town of Colonial Beach Nest Data 2023 and 2024.docx; 2013-2024 Mid Year Menhaden Harvest Analysis for Joanie Millward, Osprey 8.29.24.xlsx; Osprey Season Summary 2023-2024.xlsx; Riverkeepers temp data.xlsx; Data for Dr. Watts.docx

Dear Mr. Boyle,

My name is Joanie Millward and I am President of the Virginia Osprey Foundation based out of Colonial Beach, VA. I too, along with many others, are concerned about the decline in the osprey population in the Chesapeake Bay area and the possible connection with the lack of menhaden. In Colonial Beach, we have been monitoring nesting activity and nest failures and successes. I reached out to Marty Gary as he was the Executive Secretary of the PRFC located in Colonial Beach before taking on his new position in New York. I wanted to share our nesting data with him as compared to last year when he was in Colonial Beach. He suggested I share the same with you. The summary is actually optimistic as we have experienced more deaths since August 15th. In fact, the number of deaths was concerning enough that the Virginia Department of Wildlife Resources became involved. They are collecting our carcasses and have sent them off to the University of Georgia for necropsies. We are awaiting those results.

I ask that you take the time to look at the attached summary and would appreciate any thoughts you may have. Thank you for your time and I hope to hear from you.

**Joanie Millward, President**

**(540) 220-6387**

**<https://www.virginiaospreyfoundation.org>**



CAUTION: This email originated from outside of the organization. Do not click links or open attachments unless you recognize the sender and know the content is safe.

This is a copy of the email I received for the preliminary necropsy report.

On Wed, Sep 4, 2024 at 10:20 AM Tracey, John (DWR)

<[John.Tracey@dwr.virginia.gov](mailto:John.Tracey@dwr.virginia.gov)> wrote:

Hey All,

*The preliminary necropsy data from SCWDS would support such a theory. All 4 birds (including the outlier from Smith Mountain) were in poor body condition with very little in their GI tracts. HPAI and WNV testing was negative. They sent the livers out for heavy metal toxicology, but it'll be a while before we get that back. If they find anything else in the tissue when they do the histology, I'll let you know.*

Thanks,

John

## **Osprey Breeding Failure in Colonial Beach**

We have been monitoring approximately 58 nest sites in the town of Colonial Beach through the 2023 and 2024 breeding seasons.

In 2023, 55 hatchlings were observed that reached a size that would indicate almost full growth, the majority of these were observed to fledge. They were observed taking supplemental food from the male parent and also learning to hunt for themselves. 2 nests were seen with 3 such chicks, 17 with 2 chicks and 15 with one chick.

In 2024 there were only 44 hatchlings observed by mid-July. Of these, 16 were multiple chicks in nests. By mid-August there were no nests where multiple chicks could be seen. The fate of the others is largely unknown. They probably died in the nest. Approximately 23 chicks were essentially fully grown plus 8 other nestlings were still present.

As of 9/2/2024, 17 chicks are reported to have been transported to rehab, only one of which survived. 4 dead chicks have been recovered near nests and three dead chicks have been observed in nests. All of these chicks were malnourished and dehydrated. It is not certain that even one Osprey fledged in condition to successfully migrate.

## **High Water Temperature**

Colonial Beach experienced very high temperatures about the same time as the adult ospreys seemed to be unable to provision their young. One male, who had been seen to be an excellent provider during incubation, would depart for many hours and return without fish. Eventually, the female would leave to hunt, with mixed success. All three chicks in this nest eventually succumbed to starvation/dehydration.

Beginning in May 2023 we, under direction of the Potomac Riverkeepers, started collecting samples from three locations: Colonial Beach Pier, Colonial Beach Yacht Center and Monroe Bay Campground. Samples were typically collected on Wednesday Mornings between 9am and 10am. In addition to samples, data including water temperature and air temperature were recorded. While there is not a causal link established, it is possible that elevated temperatures could be contributing to the problem

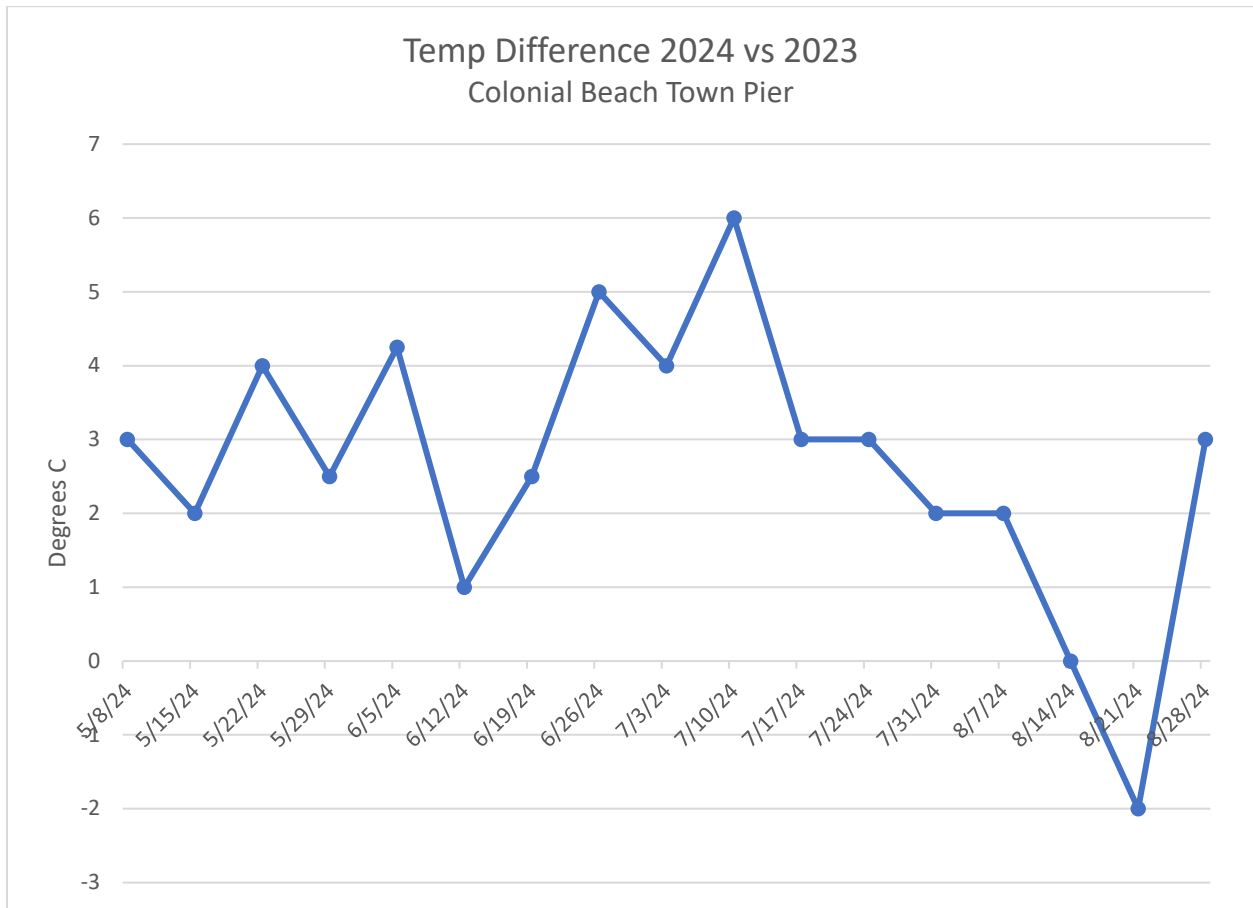
Unfortunately, our temperature data was only recorded on paper, so was not immediately available. The Riverkeepers data is stored at the Potomac River Fisheries Commission in Colonial Beach. My husband and I went to the PRFC and went through all of the data sheets to digitize the temperature data for the last two seasons. Data is included in the attached spreadsheet. The following charts show that the water temperature difference each week for the three testing locations generally falls between 2 and 7 degrees C throughout the breeding and fledging season. We do not know if that kind of temperature difference could be a contributing factor.

## **Lack of Menhaden**

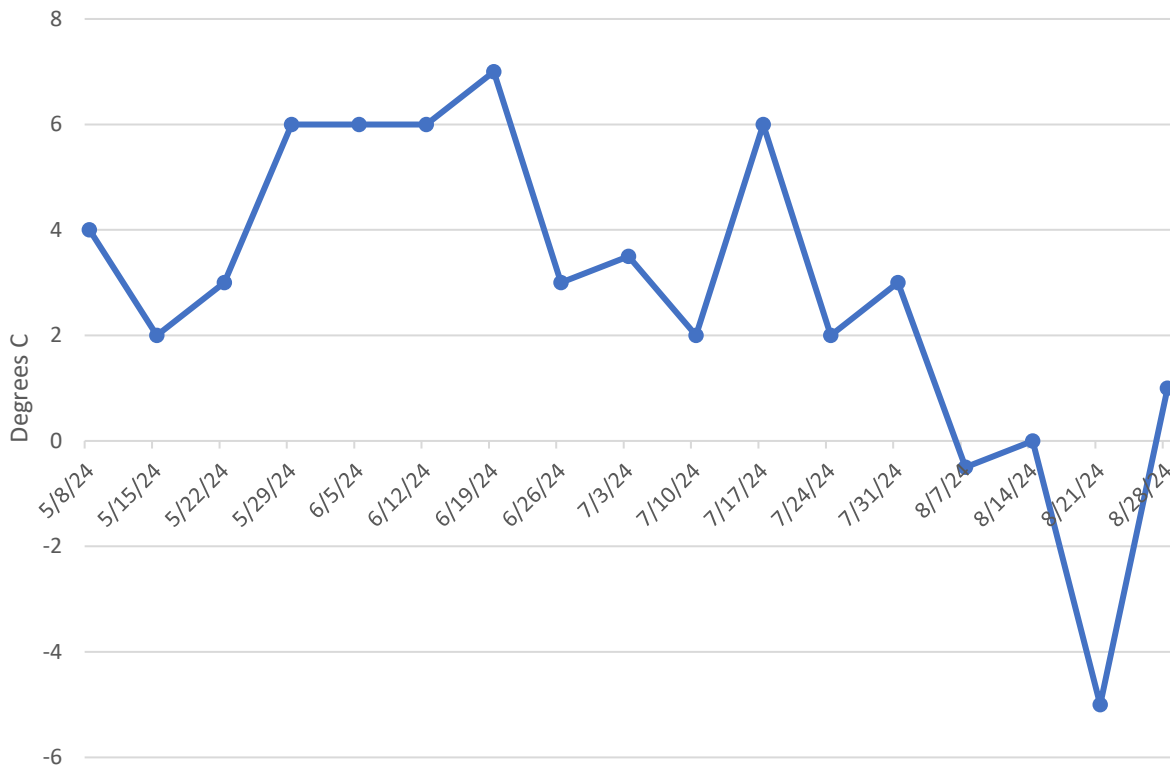
While at the PRFC we had a conversation with PRFC personnel regarding the situation of our local osprey population. The Assistant Secretary of the PRFC observed that the harvest of Menhaden in the Potomac this year is about 10% of the 10 year average! She stated that it seems that the menhaden did not come into the Potomac this year. All our local fisherman are seeing are "peanuts". Crabbers are having to buy bait elsewhere as there are essentially no Menhaden in the area. Total harvest of Menhaden in the

Potomac is estimated to be 250,000 pounds. The lowest annual harvest in the last ten years before this is over 2,000,000 pounds. Data for annual harvest and YTD harvest are attached.

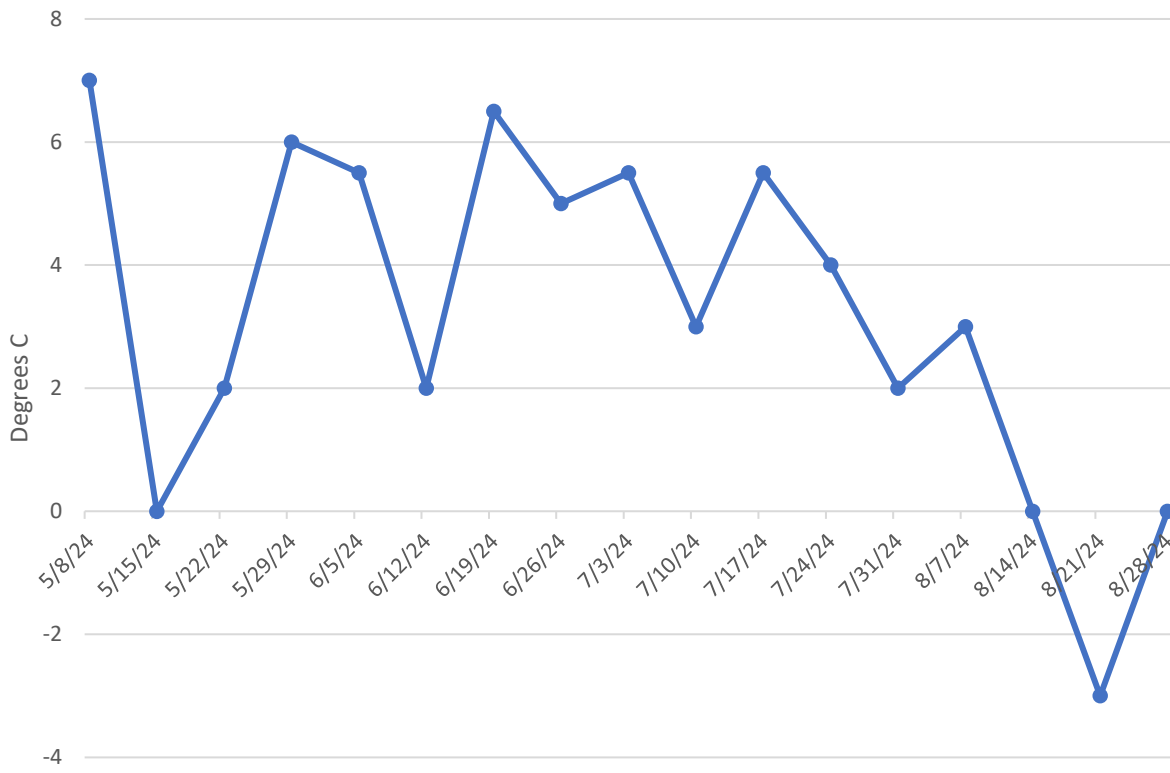
Anecdotally, we have heard that local watermen have given up harvesting menhaden for bait in the Potomac as “there are no fish”



### Temp Difference 2024 vs 2923 Monroe Bay Campground



### Temp Difference 2024 vs 2023 Colonial Beach Yacht Center



Town of Colonial Beach Nest Data 2023/2024 as of August 15, 2024

	2023	2024
<b>NEST SITES MONITORED</b>	58	58
<b>NEWLY IDENTIFIED NESTS</b>	4	2
<b>OCCUPIED NESTS</b>	49	47
<b>NESTS WITH CHICKS</b>	33	36
<b># OF CHICKS HATCHED</b>	57	44
<b># OF CHICKS FLEDGED**</b>	55	23
<b>NESTS FLEDGING 3</b>	2	0
<b>NESTS FLEDGING 2</b>	17	2
<b>NESTS FLEDGING 1</b>	15	19
<b>STILL IN NEST</b>		8

\*\* Fledged or mature enough to fledge



# The Free Lance-Star

## Cyclones surge by 'Hawks

Clatterbaugh's two third-quarter TDs spark Eastern View. **SPORTS, PAGE B1**



## Cool the burn

Find relief from acid reflux. **HEALTH, PAGE C1**



Sunday, September 22, 2024

WHERE YOUR STORY LIVES

Fredericksburg.com • \$4



PHOTO BY ROBERT LENNOX, COURTESY OF THE VIRGINIA OSPREY FOUNDATION

In better times, an osprey mother, right, feeds a morsel of fish to one of two good-size chicks in a nest at Colonial Beach. Most of this year's osprey chicks died from starvation.

# Colonial Beach's osprey season was 'a disaster'

### Starvation, climate change likely causes

**CATHY DYSON**  
The Free Lance-Star

Colonial Beach residents celebrated the number of osprey nests in the Potomac River town this spring and summer — as volunteers banded four times more chicks this year than 2023 — then their delight turned to despair.

From late July to early September, the majority of osprey chicks died. Their feathered carcasses were seen by drones that hovered over the nests, built on pilings and platforms in and around the town. Or the birds fluttered to the ground, too weak to fly. They were quickly shuttled to rehabilitators in the Tidewater area but couldn't be helped.

"It's a sad state, I have never

seen anything like this," said Joanie Millward, president of the Virginia Osprey Foundation based in Colonial Beach. "I can't say what happened, I'm not a scientist, I'm not a researcher, but what we do know is they starved to death."

What caused the starvation is the bigger question. Speculation ranges from the lack of menhaden — an oily fish full of nutrients found in Chesapeake Bay waters — to the impact of climate change. Warmer water may be causing fish to go deeper, making it harder for surface fishers like osprey to catch them with their talons.

But for Colonial Beach residents, who've watched nearby nests from back porches and docks, the events have been devastating. The osprey has become as iconic to the town as golf

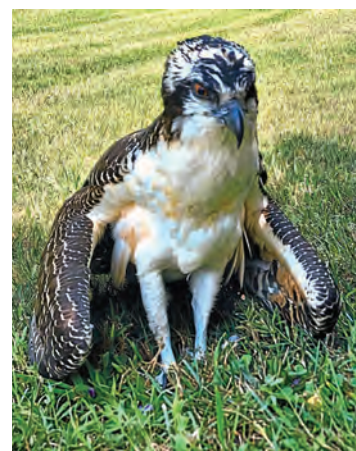
cars, and one display along the boardwalk combines both. Visitors can hop into the front seat of a golf cart that has the word LOVE spelled out in wooden letters behind them.

An image of an osprey sits in a platform nest atop the letter "L." Mary Wenz, who in recent years formed the Colonial Beach Wildlife Facebook group to rescue animals in distress, watched as osprey parents seemed to abandon the nests before teaching the young to fly or fish on their own.

She couldn't intervene, saying it's against the Migratory Bird Treaty Act to interfere with an active nest.

"We had to just watch," Wenz said. "We felt helpless, it was such an awful, awful summer. It was like which baby was going to

Please see **OSPREY**, Page A6



PROVIDED BY THE VIRGINIA OSPREY FOUNDATION

This osprey chick fluttered from its nest into a resident's yard and was so weak, it let Joanie Millward pick it up and move it into the shade. She and others tossed it a bait fish to eat, but the bird died within the hour.

# Talk focuses on Va. successes in government

### Chief transformation officer fields queries from Senate group

**MICHAEL MARTZ**  
Richmond Times-Dispatch

Rob Ward's job is transformation of state government operations under one of Gov. Glenn Youngkin's signature initiatives, based on an executive order he signed in his first day in office.

Ward, who became chief transformation officer in April after serving as the governor's real estate adviser, recently pitched the office's accomplishments to a committee of mostly skeptical legislators.

Those accomplishments include vast improvements in customer wait times at the Department of Motor Vehicles, elimination of a massive backlog of unemployment claims at the Virginia Employment Commission and ongoing efforts to im-



YOUNGKIN ADMINISTRATION

Rob Ward pitched improved wait times at DMVs and the end of the VEC backlog.

prove care for Virginians with behavioral health disabilities and to ensure that previously incarcerated people return to society successfully.

"I feel like I've been given the keys to a high-performance vehicle," Ward said in an interview

with the Richmond Times-Dispatch.

But Sen. Creigh Deeds, D-Charlottesville, wanted to talk to the chief transformation officer about issues he hadn't discussed: the administration's handling of state-owned real estate in Richmond and the \$110 million revenue shortfall over two years at the Alcoholic Beverage Control Authority under a budget that Ward's predecessor had helped to fashion.

In both cases, Ward said he has nothing more to do with state real estate decisions or operations at the ABC, but that didn't satisfy Deeds.

"There are just a ton of questions," the senator said after Ward's presentation to the Senate Finance & Appropriations Committee on Tuesday.

Those questions, particularly from the Democrats who control the General Assembly, focus on whether the Republican governor has used the chief transfor-

mation officer and a host of private consultants to undermine the independence of ABC and undercut the general services agency that oversees real estate, construction and purchase of goods and services for state agencies.

"Every governor wants to come in and make their mark, but they only have four years," Deeds said Thursday. "Has the transformation officer produced the kind of long-haul savings for the commonwealth that are going to outlast those four years? I don't see that happening."

"I'm just frustrated by the whole thing," he added.

Deeds, who serves as chairman of the Virginia Behavioral Health Commission, gives Youngkin credit for his "Right Help Right Now" initiative to improve care for people with mental health disorders and developmental disabilities, which

Please see **TRANSFORMATION**, Page A6

# America's politics in unknown territory

**STEVE PEOPLES**  
Associated Press

FLINT, Mich. — The FBI is investigating suspicious packages sent to elections officials in more than a dozen states. State police have begun sweeps of schools in an Ohio community where conspiracy theories have fueled bomb threats. Violent rhetoric is rippling across social media.

And for the second time in nine weeks, a gunman apparently sought to assassinate Republican presidential nominee Donald Trump.

This year's campaign for the White House was always going to be fraught, the first presidential election to play out in the wake of an insurrection at the U.S. Capitol, an act of political violence steeped in the lie that the 2020 election was stolen.

But the series of unnerving developments has crystallized the volatility coursing through the country in the final weeks of the 2024 campaign. A political system long lauded for its resilience and durability is being tested, with law enforcement, political leaders and voters navigating complex and unfamiliar terrain.

In Flint, the Michigan city where a contaminated water crisis became a symbol of government ineptitude nearly a decade ago, some who gathered for a Trump event this week seemed almost resigned to a new and dangerous normal.

"I think it'll probably happen one more time," John Trahan, 62,

Please see **POLITICS**, Page A16

# Secret Service's next challenge is UN meeting

### Next week's assembly brings more than 140 world leaders to NYC

**MICHAEL R. SISAK**  
Associated Press

UNITED NATIONS — Below United Nations headquarters, a state-of-the-art security post dubbed the "Brain Center" hums with activity on the eve of next week's high-level meeting of the U.N. General Assembly. The annual diplomatic pilgrimage is bringing more than 140 world leaders to New York City, including the leaders of Israel, the Palestinians and Ukraine.

Keeping them safe is the U.S. Secret Service's next big challenge.

The agency, under a cloud after a July assassination attempt on former President Donald Trump, is confident in its multi-layer, multi-agency plan to protect the U.N. General Assembly, which is deemed a Super Bowl-level National Special Security Event.

The plan — developed with New York City police and the U.N. Security and Safety Service, among other agencies — includes

Please see **SECURITY**, Page A16

**Love funnies?** Subscribers can find more comics, puzzles and columns at [go.fredericksburg.com/comics](http://go.fredericksburg.com/comics). Point your smartphone camera at the QR code, then tap the link. **NEWSVU**

**Weather**  
Not as warm but humid  
**High 74 • Low 60**  
FORECAST • B8

**Inside**  
ADVICE D3 COMICS INSIDE HOROSCOPE D3  
BOOKS C4 COMMUNITIES A10 OBITUARIES A5  
CLASSIFIEDS D1 HEALTH C1 OPINION A14







## Potomac River Fisheries Commission Harvest of Menhaden - Mid-Year Analysis

---

Day Entered	Cumulative Harvest in Pounds	Total Annual Harvest in Pounds
7/9/13	1,384,406	3,295,295
7/10/14	1,035,450	3,175,893
7/10/15	1,041,032	2,739,035
7/8/16	1,170,555	2,504,823
7/12/17	809,416	2,114,763
7/9/18	2,106,344	3,323,014
7/8/2019	724,525	2,341,823
7/10/2020	939,971	2,189,817
7/8/2021	788,571	2,536,318
7/8/2022	1,310,208	3,569,450
7/7/2023	842,315	2,051,020
7/9/2024	154,825	Preliminary* 254,180 as of 8/27/24

### **Averages**

---

2013-2023	1,104,799
2020-2023	970,266

\*Final data not released until March 2026

# Atlantic States Marine Fisheries Commission

## American Eel Management Board

*October 22, 2024*

*4:30 – 5:30 p.m.*

### Draft Agenda

The times listed are approximate; the order in which these items will be taken is subject to change; other items may be added as necessary

1. Welcome/Call to Order (*K. Kuhn*) 4:30 p.m.
2. Board Consent 4:30 p.m.
  - Approval of Agenda
  - Approval of Proceedings from May 2024
3. Public Comment 4:35 p.m.
4. Review and Provide Feedback on CITES Actions and Committee Work (*D. Hahn*) 4:45 p.m.
5. Consider Approval of Fishery Management Plan Review and State Compliance for 2023 Fishing Year (*C. Starks*) **Action** 5:15 p.m.
6. Other Business/Adjourn 5:30 p.m.

The meeting will be held at The Westin Annapolis (100 Westgate Circle, Annapolis, Maryland; 888.627.8994) and via webinar; click [here](#) for details

# MEETING OVERVIEW

## American Eel Management Board

October 22, 2024

4:30 – 5:30 p.m.

Chair: Kris Kuhn (PA) Assumed Chairmanship: 10/23	Technical Committee Chair: Danielle Carty (SC)	Law Enforcement Committee Rep: Rob Beal (ME)
Vice Chair: Jesse Hornstein (NY)	Advisory Panel Chair: Grant Moore (MA)	Previous Board Meeting: May 1, 2024
Voting Members: ME, NH, MA, RI, CT, NY, NJ, PA, DE, MD, PRFC, VA, NC, SC, GA, FL, DC, NMFS, USFWS (19 votes)		

### 2. Board Consent

- Approval of Agenda
- Approval of Proceedings from May 2024

**3. Public Comment** – At the beginning of the meeting, public comment will be taken on items not on the agenda. Individuals that wish to speak at this time must sign-in at the beginning of the meeting. For agenda items that have already gone out for public hearing and/or have had a public comment period that has closed, the Board Chair may determine that additional public comment will not provide additional information. In this circumstance, the Chair will not allow additional public comment on an issue. For agenda items that the public has not had a chance to provide input, the Board Chair may allow limited opportunity for comment. The Board Chair has the discretion to limit the number of speakers and/or the length of each comment.

### 4. Review and Provide Feedback on CITES Actions and Committee Work (4:45-5:15 p.m.)

#### Background

- The Convention on International Trade in Endangered Species (CITES) Standing Committee formed an intersessional work group on eels. The work group will provide recommendations to the Standing Committee in February 2025 regarding eel species that could impact the US eel fishery.

#### Presentations

- CITES Actions and Committee Work by D. Hahn

### 5. Consider Fishery Management Plan Review and State Compliance Reports for the 2023 Fishing Year (5:15-5:30 p.m.) Action

#### Background

- State Compliance Reports were due on September 1, 2024.
- The Plan Review Team reviewed each state report and compiled the annual FMP Review (**Briefing Materials**).
- New Hampshire, Massachusetts, Pennsylvania, District of Columbia, and Georgia have requested and meet the requirements for *de minimis* for their yellow eel fisheries. Florida requested but does not qualify for *de minimis* as the state landings in 2023 exceed 1% of the coastwide yellow eel landings.

**Presentations**

- Fishery Management Plan Review for the 2023 Fishing Year for American Eel by C. Starks

**Board Actions for Consideration**

- Approve Fishery Management Plan Review, State Compliance Reports, and *de minimis* requests

**6. Other Business/Adjourn (5:30 p.m.)**

## American Eel

**Activity level: Low**

**Committee Overlap Score:** Medium (SAS overlaps with BERP, Atlantic herring, horseshoe crab)

### Committee Task List

- TC – July 2025 review of Maine’s aquaculture proposal
- TC – September 1<sup>st</sup>: Annual compliance reports due

**TC Members:** Danielle Carty (SC, TC Chair), Alexis Park (MD), Bradford Chase (MA), Caitlin Craig (NY), Casey Clark (ME), Chris Adriance (DC), Chris Wright (NOAA), Ingrid Braun (PRFC), Jennifer Pyle (NJ), Jordan Zimmerman (DE), Troy Tuckey (VIMS), Jim Page (GA), Kevin Molongoski (USGS), Kimberly Bonvechio (FL), Mike Porta (PA), Patrick McGee (RI), Robert Atwood (NH), Sheila Eyster (USFWS), Tim Wildman (CT), Todd Mathes (NC), Caitlin Starks (ASMFC)



**DRAFT PROCEEDINGS OF THE  
ATLANTIC STATES MARINE FISHERIES COMMISSION  
AMERICAN EEL MANAGEMENT BOARD**

**The Westin Crystal City  
Arlington, Virginia  
Hybrid Meeting**

**May 1, 2024**

These minutes are draft and subject to approval by the American Eel Management Board.  
The Board will review the minutes during its next meeting.

**TABLE OF CONTENTS**

Call to Order, Chair Kris Kuhn ..... 1

Approval of Agenda ..... 1

Approval of Proceedings from January 23, 2024 ..... 1

Public Comment ..... 1

Consider Addendum VI on Maine Glass Eel Quota for Final Approval..... 1

    Review Options and Public Comment Summary ..... 2

    Advisory Panel Report..... 3

    Consider Approval of Addendum VI ..... 4

Consider Addendum VII on Yellow Eel Yellow Eel Coastwide Cap and Monitoring for Final Approval ..... 5

    Review Options and Public Comment Summary ..... 5

    Advisory Panel Report..... 9

    Consider Approval of Addendum VII ..... 12

Elect Vice-Chair..... 24

Other Business..... 24

    CITES Update..... 24

Adjournment ..... 25

**INDEX OF MOTIONS**

1. **Approval of agenda** by consent (Page 1).
2. **Approval of Proceedings of January 23, 2024** by consent (Page 1).
3. **For Draft Addendum VI, move to select under 3.1 Maine Glass Eel Quota, Option 1: Status Quo (9,688 lbs. quota) and under 3.2 Timeframe for Maine Glass Eel Quota, Option 3 (Three years, with the ability to extend via Board action)** (Page 4). Motion by Megan Ware; second by Doug Grout. Motion passes by consent (Page 4).
4. **Move to approve Addendum VI to the American Eel FMP, as modified today** (Page 4). Motion by Megan Ware; second by John Clark. Motion passes by consent (Page 5).
5. **Main Motion**  
**Move to approve under 3.1 Issue 1 Option 1 status quo** (Page 14). Motion by John Clark; second by Russel Dize. Motion substituted.  
  
**Motion to Substitute**  
**Move to substitute to replace “under 3.1 Issue 1 Option 1 status quo” with “under 3.1 Issue 1 Option 2 (202,453 lbs.)** (Page 15). Motion by Justin Davis; second by Rick Jacobson. Motion fails (3 in favor, 16 opposed) (Page 17).  
  
**Motion to Substitute**  
**Motion to substitute to approve under 3.1 Issue 1 Option 3 to set the coastwide cap at 518,281 pounds** (Page 17). Motion by Shanna Madsen; second by Dan McKiernan. Motion passes (12 in favor, 6 opposed) (Page 19).  
  
**Main Motion as Substituted**  
**Move to approve under 3.1 Issue 1 Option 3 to set the coastwide cap at 518,281 pound.**  
  
**Motion to Substitute**  
**Move to substitute to approve under 3.1 Issue 1 Option 5 to set the coastwide cap at 716,497 pounds** (Page 20). Motion by Lynn Fegley, second by Steve Train. Motion fails (7 in favor, 12 opposed) (Page 20).  
  
**Main Motion as Substituted**  
**Move to approve under 3.1 Issue 1 Option 3 to set the coastwide cap at 518,281 pounds.** Motion passes (15 in favor, 4 opposed) (Page 20).
6. **Move to approve:**
  - **For Section 3.1, Issue 2, Option 1 [Status Quo, >1% coastwide landings]**
  - **For section 3.5, Option 2 (3-year landings average for de minimis)**(Page 21). Motion by Lynn Fegley; second by John Clark. Motion passes (15 in favor, 2 opposed, 2 abstentions) (Page 21).
7. **Move to approve for Section 3.2, Option 1 (three years coastwide cap duration** (Page 22). Motion by Shanna Madsen; second by John Clark. Motion passes (18 in favor, 1 abstention) (Page 22).

These minutes are draft and subject to approval by the American Eel Management Board.  
The Board will review the minutes during its next meeting.

8. **Main Motion**

**Move to approve:**

- **For Section 3.3, Option 1 (Status Quo);**
- **For Section 3.4, Option 1 (mandatory CPUE data collection)**

(Page 22). Motion by Jeff Kaelin; second by Lynn Fegley. Motion amended.

**Motion to Amend**

**Move to amend to replace Option 1 with Option 2 for section 3.3** (Page 22). Motion by John Clark; second by Doug Grout. Motion passes (16 in favor, 2 opposed, 1 abstention) (Page 22).

**Main Motion as Amended**

**Move to approve:**

- **For Section 3.3, Option 1 (Status Quo);**
- **For Section 3.4, Option 1 (mandatory CPUE data collection)**

Motion passes (18 in favor, 1 opposed) (Page 23).

9. **Move to approve Addendum VII to the American Eel FMP, as modified** (Page 23). Motion by Emerson Hasbrouck; second by Roy Miller. Motion passes by consent (Page 23).
10. **Move to approve an implementation date of January 1, 2025** (Page 24). Motion by John Clark; second by Joe Cimino. Motion passes (18 in favor, 1 opposed) (Page 24).
11. **Move to elect Jesse Hornstein as Vice-Chair** (Page 24). Motion by Joe Cimino; second by Lynn Fegley. Motion passes by consent (Page 24).
12. **Move to adjourn** by consent (Page 25).

**ATTENDANCE**

**Board Members**

Megan Ware, ME, proxy for P. Keliher (AA)	Kris Kuhn, PA, proxy for T. Schaeffer (AA)
Steve Train, ME (GA)	Loren Lustig, PA (GA)
Rep. Allison Hepler, ME (LA)	John Clark, DE (AA)
Renee Zobel, NH, proxy for C. Patterson (AA)	Roy Miller, DE (GA)
Doug Grout, NH (GA)	Craig Pugh, DE, proxy for Rep. Carson (LA)
Dennis Abbott, NH, proxy for Sen. Watters (LA)	Lynn Fegley, MD (AA, Acting)
Dan McKiernan, MA (AA)	Russel Dize, MD (GA)
Raymond Kane, MA (GA)	Shanna Madsen, VA, proxy for J. Green (AA)
Sarah Ferrara, MA, proxy for Rep. Peake (LA)	Chris Batsavage, NC, proxy for K. Rawls (AA)
Phil Edwards, RI, proxy for J. McNamee (AA)	Chad Thomas, NC, proxy for Rep. Wray (LA)
David Borden, RI (GA)	Ross Self, SC, proxy for B. Keppler (AA)
Justin Davis, CT (AA)	Doug Haymans, GA (AA)
William Hyatt, CT (GA)	Spud Woodward, GA (GA)
Robert LaFrance, CT, proxy for Rep. Gresko (LA)	Jeffrey Renchen, FL, proxy for J. McCawley (AA)
Marty Gary, NY (AA)	Gary Jennings, FL (GA)
Emerson Hasbrouck, NY (GA)	Dan Ryan, DC, proxy for R. Cloyd
Jesse Hornstein, NY, proxy for Sen. Kaminsky (LA)	Ron Owens, PRFC
Joe Cimino, NJ (AA)	Chris Wright, NMFS
Jeff Kaelin, NJ (GA)	Rick Jacobson, US FWS
Adam Nowalsky, NJ, proxy for Sen. Gopal (LA)	

**(AA = Administrative Appointee; GA = Governor Appointee; LA = Legislative Appointee)**

**Ex-Officio Members**

**Staff**

Bob Beal	Caitlin Starks	Katie Drew
Toni Kerns	Emilie Franke	Kristen Anstead
Tina Berger	Chelsea Tuohy	Jainita Patel
Madeline Musante	James Boyle	Kurt Blanchard
Tracy Bauer	Jeff Kipp	

**Guests**

Travis Atwood , MEFA	James Cassin, NOAA	Micah Dean, MA DMF
Pat Augustine	Matthew Cieri, ME DMR	Danny Deraps, MSN
Mel Bell	Michael Clough	Adam Dragon, MEFA
Sue Bertoline	Allison Colden, CBF	Roman Dudus
Alan Bianchi, DC DMF	Margaret Conroy, DE DNREC	Paul Eidman, Reel Therapy
Jason Boucher, NOAA	Heather Corbett, NJ DEP	Fishing Charters
Colleen Bouffard, CT DEEP	Caitlin Craig, NYS DEC	Julie Evans, East Hampton Town
Michael Bowen, Cornell	Scott Curatolo-Wagemann,	Fisheries Advisory Cmte.
Univeristy	Cornell Cooperative Extension	Sheila Eyler, US FWS
Jeffrey Brust, NJ DFW	of Suffolk County	

These minutes are draft and subject to approval by the American Eel Management Board.  
The Board will review the minutes during its next meeting.

Draft Proceedings of the American Eel Management Board – May 2024

Peter Fallon, Maine Assn. of Charterboat Captains	Eric Marek, US FWS	Stephanie Richards, MD DNR
Corrin Flora, MA DMR	Todd Mathes, NC DMF	Harry Rickabaugh, MD DNR
Tom Fote, JCAA	Joe McDonald	Sefatia Romeo Theken, MA DFG
Anthony Friedrich, ASGA	Joshua McGilly, VMRC	Bryan Rosa, Origin Outfitters
Lewis Gillingham, VMRC	Jack McGovern, NOAA	Zachary Schuller, NYS DEC
Willam Gorham, Bowed up Lures	Kevin McMenamin, Annapolis Anglers Club	McLean Seward, NC DEQ
Harry Hornick, MD DNR	Jason McNamee, RI (AA)	Alexei Sharov, MD DNR
Stephen Jackson, US FWS	Meredith Mendelson, ME DMR	David Sikorski
James Jewkes	Nichola Meserve, MA DMF	John Sweka, US FWS
Fred Johnson	Steve Meyers	Rustin Taylor, Maine Elver Fisherman's Assn.
Amy Karlnoski, NYS Assembly	Chris Moore, Chesapeake Bay Foundation	Kristen Thiebault, MA DMF
Carrie Kennedy, MD DNR	Jeff Moore, NC DMF	Peter Whelan
Gregg Kenney, NYS DEC	Nicole Ogrysko, Maine Public Radio	Keith Whiteford, MD DNR
Andrew Konchek	Alexis Park, MD DNR	Patrick Whittle
Robert LaCava, MD DNR	Cheri Patterson, NH (AA)	Travis Williams, NC DEQ
Laura Lee, US FWS	Gregory Pavlov	Al Williams
Brooke Lowman, VMRC	Jennifer Pyle, NJ DEP	Daniel Zapf, ND DEQ
Michael Luisi, MD DNR	Jill Ramsey, VMRC	Jordan Zimmerman, DE DNREC
John Maniscalco, NYS DEC		

These minutes are draft and subject to approval by the American Eel Management Board.  
The Board will review the minutes during its next meeting.

The American Eel Management Board of the Atlantic States Marine Fisheries Commission convened in the Jefferson Ballroom of the Westin Crystal City Hotel, Arlington, Virginia, via hybrid meeting, in-person and webinar; Wednesday, May 1, 2024, and was called to order at 3:00 p.m. by Chair Kristopher M. Kuhn.

### **CALL TO ORDER**

CHAIR KRISTOPHER M. KUHN: Good afternoon, everyone, welcome to the Atlantic States Marine Fisheries Commission American Eel Management Board. I'm calling this meeting to order. I'm Kris Kuhn, the Administrative Proxy for Pennsylvania, and current Chair of the American Eel Board.

Currently we have the Vice-Chair position vacant, but will be considering filling that role later in this meeting. Our Technical Committee Chair is Danielle Carty from South Carolina, and we have a new Advisory Panel Chair; Mitch Feigenbaum from Pennsylvania. Mitch is certainly not new to the AP or ASMFC participation, but I would like to welcome him into his renewed role as AP Chair.

I would also like to thank our previous AP Chair, Mari-Beth DeLucia with the Nature Conservancy, for her longstanding service and leadership in that capacity. Our Law Enforcement Committee representative is Rob Beal from Maine, and I'm joined here at the front table by Caitlin Starks and Dr. Kristen Anstead with the Commission, Law Enforcement Committee Rep Rob Beal, and AP Chair Mitch Feigenbaum.

### **APPROVAL OF AGENDA**

CHAIR KUHN: We have a full agenda here this afternoon, so let's go ahead and get started with this afternoon's business. The first order of which is Approval of the Agenda. Are there any proposed modifications to the agenda? Any hands online? Seeing none; the agenda is approved by consent.

### **APPROVAL OF PROCEEDINGS**

CHAIR KUHN: Next up, Approval of Proceedings from the January, 2024 Board Meeting. Are there any edits to the proceedings from the January, 2024 meeting of the American Eel Management Board? Okay, seeing none there again they are approved by consent.

### **PUBLIC COMMENT**

CHAIR KUHN: Now we'll move on to the Public Comment period. Are there any members of the public either here or online that would like to make comment pertaining to items that are not on today's agenda?

Again, this is only for items that are not on the agenda. Depending on time, you will be given additional opportunity to comment on motions for specific items to be covered in the agenda later in this meeting. Also, as a reminder to Commissioners and others making comments in the room, please move your microphone down and ensure that it is turned on when speaking, so we can hear you. Anyone wishing to make public comment at this time for items not on the agenda? Okay, seeing none

### **CONSIDER ADDENDUM VI ON MAINE GLASS EEL QUOTA FOR FINAL APPROVAL**

CHAIR KUHN: We'll go ahead and move on to the fourth item that is on the agenda, which is to Consider Addendum VI, pertaining to Maine Glass Eel Quota for Final Approval. Draft Addendum VI was approved for public comment in January, and today the Board meets to select management options and implementation dates, and provide final approval of Addendum VI.

Specifically, this includes deciding upon Maine's glass eel quota, and a timeframe for implementation. Caitlin Starks is going to start us off with a presentation. Following that I'll turn it over to AP Chair, Mitch Feigenbaum for an Advisory Panel report pertaining to, specifically Addendum VI. Then we'll take questions on the presentation

These minutes are draft and subject to approval by the American Eel Management Board.  
The Board will review the minutes during its next meeting.

and report. Caitlin, we're ready for your presentation.

### **REVIEW OPTIONS AND PUBLIC COMMENT SUMMARY**

MS. CAITLIN STARKS: I'm going to go over Eel Draft Addendum VI, again this is on Maine glass eel quota and eel/elver management. I'm going to start with the background and statement of the problem for this Addendum, and then go over the proposed management options, the summary of the public comments, and then we'll go over to the AP Chair for the AP report, and finally the Board action for consideration today.

Draft Addendum VI was initiated in August, 2023, when the Board moved to initiate and addendum to address the Maine glass eel quota. Following that meeting the Plan Development Team, PDT, developed the Draft Addendum Document for public comment. Our public comment period was in February and March of this year, and then today the Board will consider those comments and take final action on this addendum.

If approved today, the implementation of the measures is expected in time for January, 2025. That timeline is important, and the reason for this Addendum is because Maine's commercial glass eel quota expires after this year, and so it needs to be reestablished for 2025 and beyond. The quota was set for 2015 through 2017 and 9,688 pounds by Addendum IV in 2014, and then Addendum V maintains the same quota, which was extended through Board action through 2024.

However, a new addendum was needed for fishing beyond 2024. Now I'll just go through the proposed management action. This is a pretty short and sweet Addendum, so the first couple options here, well one option, is related to the Maine glass eel quota level. Option 1 is status quo, that would be 9,688 pounds.

This is maintaining the same quota that has been in place since 2015. Before the Addendum was approved for public comment there was an additional option to consider reducing that quota, but the Board decided to remove that option from consideration. If no action is taken on this Addendum, then there would not be a quota for Maine in the Commission's FMP.

The next set of options is Section 3.2, and these address the duration of the quota that will be established at final action. Option 1 is for no sunset, and that would mean the Maine glass eel quota would just remain the same indefinitely, unless changed through another addendum or amendment. Then Option 2 is a 3-year duration after which the Board would be required to initiate a new addendum to establish Maine's glass eel quota for 2028 and beyond. Then Option 3 is a 3-year duration after which the Board could extend the same quota indefinitely via Board action. However, if a change to the quota is desired under this option, there would still need to be a new addendum and public input process. Now for the Public Comment Summary. During our comment period we had one virtual public hearing, and that was called at the end of February.

We had 23 attendees from the public, but no comments were provided during that hearing. We received 35 total written comments, and I want to note that this number is revised from what was in the memo in the materials, in order to account for all of the signatories that were signed on to a single comment, when there was more than one. We had 33 individual comments and 2 letters from organizations.

This table summarizes the support for each of the options in the Addendum, so 34 of the 35 written comments indicated support for the status quo quota option. Then for the quota duration, 6 indicated support for the no sunset option, and 1 favored Option 2, which would require a new addendum after 3 years.

These minutes are draft and subject to approval by the American Eel Management Board. The Board will review the minutes during its next meeting.



In the comments that supported the status quo quota option, the rationales included that they are seeing plentiful numbers of elvers in Maine, and that harvesters are easily able to fill their quotas early in the season. Some comments mentioned that they think the Maine fishery is already well managed and regulated, and also that the state has laws and conducts conservation efforts to allow harvest to continue without depleting the population.

A few folks also noted that Maine is unique, in that there are large amounts of habitat for eels in the state. Under Section 3.2 on the quota duration. For those that supported Option 1 for no sunset, the reasoning was just generally that the quota is working and it should stay in place. Then from the 1 comment that supported Option 2, which was from the Pasamaquoddy Tribe.

The letter expressed that the quota should be fully reviewed in 3 years, so that any necessary adjustments to that quota can be made based on changing conditions and information, and additionally that full review in 3 years would allow for an opportunity for the Commission to engage with and coordinate with the Tribe, with regard to this Maine glass eel fishery.

Then we have some additional comments that were not related to a specific option in the Addendum, but 3 comments said that Maine glass eel quota should be increased, rather than stay the same. They think that it wouldn't hurt the biomass, given the small number of fishermen, and also because there should be some credit given back to the fishery for dam removals and other habitat restoration projects.

Then 1 comment expressed that states without glass eel fisheries shouldn't get to vote on Maine's management, and 1 individual favored reducing or ending glass eel harvest, because of the species stock status. In the comment letter from the Pasamaquoddy Tribe, there were a few other points raised about the Commission's management.

These minutes are draft and subject to approval by the American Eel Management Board.  
The Board will review the minutes during its next meeting.

First the letter stated that the Commission should consult with the Tribe before proposing any management actions that would affect American eel and other species in their region. It also noted the opinion that ASMFC and its partners should prioritize population and habitat restoration efforts in eel management over harvest quotas. I can pass it over to Mitch for the APs report.

#### **ADVISORY PANEL REPORT**

MR. MITCH FEIGENBAUM: I can report that 2 of 5 AP members present at our meeting were representing Maine. Both supported Option 1 on the quota, as well as on the quota timeframe. Two of the other 3 AP members either supported or offered no opinion about the views of their colleagues from Maine. Not only Maine's AP members, but attendees at the State Public Meeting report that glass eel runs are strong, and note that the quota is easily reached every year.

I apologize for the redundancy. They cite the reduction of adult eel fisheries and an impressive record of dam removal as proof of the state's responsible approach to species management. While the harvester community in Maine asks the Board to consider increases to the state's glass eel quota, this matter was not addressed by the AP, since it was not an option for consideration in the Addendum. Thank you.

MS. STARKS: Thank you, and I just have one more slide to wrap up. The first item for the Board's consideration today would be the selection of management measures, and then followed by the final approval of Addendum VI.

CHAIR KUHN: At this point we'll take questions on the presentation for Caitlin or Mitch on the AP report. Yes, Dan McKiernan.

MR. DANIEL MCKIERNAN: Could I get clarification on, Mitch, the third bullet referencing the reduction of adult eel fisheries in Maine. Does Maine prohibit yellow eel harvest?

MR. FEIGENBAUM: It is my understanding that they do. I know that when the rules were imposed in Maine to eliminate the silver eel fishery and adult eel harvesting, it was grandfathering that was implemented, and I don't know the status of that. Perhaps the folks from Maine could answer better.

CHAIR KUHN: Any additional questions in the room for Caitlin or Mitch? Okay, seeing none; do we have any hands online? Okay, we have a hand from a member of the public online, but we're going to go ahead and hold that until we get to motions. You will have an opportunity to speak once we get the motions.

#### **CONSIDER APPROVAL OF ADDENDUM VI**

CHAIR KUHN: If there are no more questions on the presentation or the AP report, let's go ahead and open it up to the Board for discussion on the presentation. Megan Ware.

MS. MEGAN WARE: I had sent staff a motion to get our conversation started today.

CHAIR KUHN: We're getting that up on the board now, it looks like it's up there.

MS. WARE: For Draft Addendum VI, **move to select under 3.1 Maine Glass Eel Quota, Option 1: Status Quo (9,688 lbs. quota) and under 3.2 Timeframe for Maine Glass Eel Quota, Option 3 (Three years, with the ability to extend via Board action).**

CHAIR KUHN: Okay, do we have a second? Doug Grout. Okay, Megan, as maker of the motion would you like to provide some additional comments?

MS. WARE: I would, certainly, support maintaining our existing quota, and prefer that to not managing this fishery under a quota, which would be what we get if we don't choose Option 1 today. Just to echo some of my comments from our meeting in January. There is no recommendation coming out of the

assessment for a reduction in Maine glass eel quota. Our young of the year survey trends have been steadily increasing.

The assessment is pretty clear that harvesting glass eels has a lower impact on the population, given the high net mortality at that life stage. In terms of the timeframe, I believe our system for reviewing the glass eel quota every three years has worked well, and I hope that that provides a little more comfort to the Board today, with the status quo quota. I like Option 3 from an efficiency standpoint, because it does allow for Board action if the Board decides to maintain the quota after three years.

CHAIR KUHN: Doug, would you like to provide some additional comments?

MR. DOUGLAS E. GROUT: No, Sir.

CHAIR KUHN: Okay, before we go to the Board for discussion on the motion, I'll now accept some public comments specific to the motion. Do we have any members of the public that would like to speak or make a comment specific to this motion? Any hands online? Okay, no hands online. Let's bring this back to the Board for discussion on the motion. Is there any discussion on the motion? Okay, seeing none.

I guess we're at the point where we can call the question. Is there a need to caucus before the vote? Caucus, we'll take two minutes. Okay, two minutes are up. Is there any need for further discussion, caucus? Seeing none; we'll try and do this the easy way. **Is there any opposition to the motion? Seeing none; the motion passes by consent.** At this time, we're ready to consider final approval of Addendum VI. Is there anyone willing to make that motion? Megan Ware.

MS. WARE: Yes, I am happy to make that motion. **Move to approve Addendum VI to the American Eel FMP, as modified today.**

CHAIR KUHN: Do we have a second? John Clark. Megan, would you like to speak to that?

These minutes are draft and subject to approval by the American Eel Management Board.  
The Board will review the minutes during its next meeting.

MS. WARE: I don't have any comments.

CHAIR KUHN: John Clark. Okay, again we'll do this easy way. **Is there any opposition to the motion? Okay, seeing none, the motion is approved by Board consent.**

**CONSIDER ADDENDUM VII ON YELLOW EEL  
YELLOW EEL COASTWIDE CAP AND  
MONITORING FOR FINAL APPROVAL**

CHAIR KUHN: We'll go ahead and move on to Item 5 on the agenda, which is to Consider Addendum VII on Yellow Eel Coastwide Cap and Monitoring Requirements for Final Approval. Addendum VII was approved for public comment in January, and today the Board needs to select management options and implementation dates, and decide upon final approval of Addendum VII. Specifically, this includes deciding upon the coastwide cap, the management response to exceeding the coastwide cap, timeframe for how long the selected coastwide cap would remain in place, annual young of year abundance survey requirements, catch and effort monitoring requirements, and the American eel de minimis criteria. Caitlin Starks again is going to lead us into questions and discussion with a presentation, then we'll hear the AP report on Addendum VII from AP Chair, Mitch Feigenbaum. Caitlin, the floor is yours.

**REVIEW OPTIONS AND PUBLIC COMMENT  
SUMMARY**

MS. STARKS: This will be very similar in structure to the last presentation. I'll go over some background information and statement of the problem, the proposed management options, which are going to be a lot lengthier than the last presentation, and then the public comment summary before going to our AP Chair.

Addendum VII responds to the 2023 stock assessment, which maintains the depleted stock status and recommends reducing the catch of

yellow eels. To date the assessment hasn't been able to provide us with biologically based reference points for use for management, so instead the Board has managed eels, yellow eel, using a coastwide catch cap. That is based on historically yellow eel landings.

The most recent assessment is still unable to provide these biological reference points, but it did identify a tool that we could use to inform management of yellow eel, using fishery independent abundance indices and coastwide landings to provide catch advice. This is called I-TARGET and we'll talk about I-TARGET some more later.

This graph just shows the yellow eel abundance index, which is the dotted gray line, and the coastwide landings, which is the black line. You can see the decline in both of these indices over time. The Board initiated this Addendum, specifying in their motion that we should consider using I-TARGET to recommend various catch caps for the yellow eel commercial fishery, but not use I-TARGET, to set biological reference points or stock status.

This Addendum also considers some changes to monitoring requirements, based on recommendations from the Stock Assessment Subcommittee and Technical Committee. First the 2023 assessment indicated that biological sampling in the young of year surveys that's required, specifically the individual lengths and pigment stage, could be made optional, because these data haven't been able to inform coastwide trends in the stock.

Additionally, it notes that the catch per unit effort data that are provided by states, haven't been used in any of the stock assessments as was the intention for those data, because they have also not been indicative of trends in stock as a whole. As a reminder, this Addendum was initiated last August, and after the Board reviewed the 2023 benchmark. In the fall, the Plan Development Team put together the management options in the document, and we had our public hearings and comment period in

These minutes are draft and subject to approval by the American Eel Management Board.  
The Board will review the minutes during its next meeting.

February and March, the same time as Addendum VI.

Today, we're also having the Board discuss the comments and consider final approval of the Addendum. Just to go over the management options. These are the five sections of the Addenda that we'll talk through today. We have options on the commercial yellow eel coastwide cap, and the management response to exceeding the cap, timeframe options for that cap, young of year abundance survey requirements, catch in effort monitoring program requirements, and then finally a de minimis status. Starting with the coastwide cap. Issue 1 under 3.1. This deals with the cap level itself. Our current cap is 916,473 pounds. That is based on the average landings from 1998 to 2010. This is our status quo option, and then there are four additional options, which propose a range of alternative harvest caps using that I-TARGET tool that was recommended in the assessment. Just a quick reminder on I-TARGET.

This is a trend-based tool for managing data limited fisheries, and it uses data from landings and abundance indices, and provides a range of catch limit recommendations, based on trends in catch, abundance and management goals. Essentially, the inputs into I-TARGET are the historical catch and abundance trends, where catch and abundance levels currently are, and then the target abundance of where we want to be.

Then as an output, I-TARGET provides us with a cap recommendation for getting to that target abundance level. In addition to those basics, there are these three variables in I-TARGET that need to be defined, in order to configure the tool. We have the reference period, the multiplier and the threshold. These are the knobs that the Board needs to adjust.

The reference period is meant to be a time period where the population is stable or at a desirable abundance level, and this is the time

period of abundance that we're comparing our target abundance to. The multiplier determines the level of abundance that management is aiming to achieve. If the multiplier is set to 1, that means you're aiming to achieve the same abundance from the reference period.

If you set the multiplier to 1.25 that means you are aiming to achieve an abundance level that is 25 percent higher than the abundance from the reference period, so that is how that functions. The threshold value is a portion of the I-TARGET value that is dependent on the goals of the fishery. A threshold value of 0.5 is a less conservative value, and generally results in higher catch cap, and a threshold of 0.8 is a more conservative value that generally results in lower catch caps, and that is our range for the threshold options.

The options that use I-TARGET to recommend the catch caps, there are two different reference periods that are considered, so those are shown in this graph in the blue and yellow shaded areas. The blue shaded area is the earlier reference period, which is 1974 to 1987, and in that period the abundance index was at a higher level.

That represents a more desirable abundance level, and then in the yellow areas there is a later reference period, which is the lower level of abundance, but still above abundance levels in the most recent decades. Then this table is showing the four proposed options for coastwide caps that use I-TARGET.

Option 2 and 3, which are highlighted in blue, they use the earlier reference period and a multiplier value of 1.25, so they are using the same multiplier value and reference period, which means they are aiming to achieve the same level of stock abundance. That is 25 percent greater than the stock abundance during that reference period. They differ in that Option 2 uses a threshold of 0.8, and Option 3 uses the threshold of 0.5. The 0.8 threshold results in a coastwide cap of 202,453 pounds, and the 0.5 threshold results in 518,281 pounds, and that is based on the conservativeness of those two options. Then Option 4 and 5 use the

These minutes are draft and subject to approval by the American Eel Management Board.

The Board will review the minutes during its next meeting.

later reference period, which is 1988 to 1999. They both use a threshold value of 0.5, but Option 4 uses a multiplier of 1.5 and Option 5 uses a multiplier of 1.25. This means these two options are aiming for two different levels of stock abundance. Option 4 is aiming for 50 percent higher than the abundance during the reference period, and Option 5 is aiming for 25 percent greater than that abundance level.

Then this graph just shows those four options for coastwide cap compared to the current coastwide cap, which is the black dashed line at the top, as well as the coastwide yellow eel landings since 2015. The next set of options are related to the management response for if that coastwide cap is exceeded.

Our status quo option is that if landings exceed the cap by 10 percent for 2 consecutive years, then the state's whose landings are greater than 1 percent of the coastwide total landings in those years, would be responsible for reducing their landings to come back down to that coastwide cap in a subsequent year.

Option 2 modifies this slightly, so that it would be a response by the states whose landings are greater than 5 percent of the coastwide landings being responsible for reducing their landings. That just changes the number of states really that would be responsible. To show that difference, in this table we have some yellow and gray shaded cells.

All of these cells are states that have landings greater than 1 percent of the coastwide landings in each year. Then just the gray cells are those states with greater than 5 percent of the total in each year. Moving on to our options for timeframe. Option 1 is that the cap would not have a sunset date, but that it would need to remain in place for three years, before being updated.

That three-year minimum timeframe was recommended, because less than three years of data wouldn't be as sufficient to evaluate the

performance of that cap. Then Option 2 is that the cap would again, not have a sunset date, so that it would have to remain in place for 5 years before being updated.

To clarify what updating the cap means under these options, it would be that additional years of data, whether it's 3 or 5, would be run through the I-TARGET tool as it is configured. It doesn't mean it would be able to change the reference period, multiplier or threshold values. Next are the options related to the young of year survey sampling.

Option 1 is status quo, and this would mean the states must continue to collect individual length and pigment stage during the young of year surveys. Option 2 is that the biological sampling of those two things would become optional, and that was recommended by the SAS in the 2023 assessment. For Section 3.4 we have two options regarding the fishery dependent catch and effort monitoring.

Option 1 status quo would maintain the requirement for harvester reporting of trip level, catch per unit effort data, and that was established by Addendum I. This means the states would continue to require those CPUE data and harvester reports, including soak time, number of units of gear fished and pounds landed. Then Option 2 would be that the states would no longer be required to collect those trip level CPUE data for yellow eel catch. The states would be able to continue that collection of the data if they chose to, and the majority of states indicated that they would likely continue collecting those data, even if it were voluntary. But as a note, this option does not apply to glass eel, it just applies to the yellow eel surveys. Then our last section is de minimis status options.

The Commission approved a new standard for the de minimis policy, and that is to use an average of three years of landings to evaluate whether a state meets the de minimis criteria. Our status quo option would be to continue using two years, which is what is currently in the eel FMP, and Option 2 would be to update the eel FMP to use the three-year average, which is now the Commission standard. If Option 1 is chosen, then our policy

These minutes are draft and subject to approval by the American Eel Management Board.

The Board will review the minutes during its next meeting.

indicates that the Board would need to provide a rationale for why two years is more appropriate for this species.

Now we can go through the summary of public comments on this Addendum. We had six public hearings during the comment period for Addendum VII in February and March, and combined the attendance across all of those hearings was 37 individuals, and 23 comments were provided at hearing. We also received a total of 10 written comments on the Addendum, 9 of which were from individuals, and one letter from the Maryland Watermen's Association.

This table just summarizes the support for the different options indicated by the comments. The main takeaway here is that the public generally supported the status quo option for the coastwide cap for yellow eel. Only one person commented in favor of the different option, which was Option 5. There was not a strong response about the other options in the Addendum.

Three people supported the status quo management response to exceeding the coastwide cap, 6 supported the timeframe option for 3 years before the cap is updated, and 3 supported the 5-year option. Then 3 people supported status quo for keeping the requirements for young of year biosampling, and 3 supported status quo for keeping the requirement for trip level harvester CPUE data, and 3 supported status quo for de minimis.

As you just saw, we got 28 comments in favor of the status quo coastwide cap, and the rationales given were that the fishery does not have an overfished or overfishing status, that effort and landings for yellow eel have declined because of the market and fishing cost, not because of decreased eel abundance.

The status quo option would allow for the fishery to grow back to previous levels if the market were to recover in the future. They also

commented that more data are needed for the years after COVID, when things came more back to normal. Then the 1 individual in favor of Option 5 noted that this option would also still allow for growth of the fishery, and wouldn't limit it too much.

Regarding the timeframe for the coastwide cap. There was more support for the 3-year option. General thinking behind that was that within three years the data could be improved, and the update to the cap would possibly benefit the fishery sooner rather than later. Then the 3 individuals in favor of the 5-year timeframe preferred having more years of data. For the young of year biosampling, the support was mainly for status quo, but there weren't really reasons provided for that. For the CPUE data collection options, the supporters of status quo did express some concerns about losing that information on the harvester CPUE, because they do think it's important for assessing the fishery. Then for the de minimis options, 3 were in support of status quo, but again no reasons were given. Then these are some additional comments we received during the period of public comment that weren't necessarily tied to certain options in the Addendum. Several folks commented that we do not need any changes for yellow eel management.

There was also a group that commented about the coastwide cap option, saying that even though they prefer status quo, they were skeptical that status quo would be the outcome of the Board's decision, so they wanted to emphasize that Option 5 was the next best option in their opinion. Then a few individuals mentioned that we need better data for assessing eel abundance, and that the CPUE data would be better if they were collected by fishermen who have more experience, and know how to catch eels.

There were also some comments that mentioned some concerns about illegal catch of undersized eel and foreign aquaculture markets, both affecting the U.S. industry in a negative way. There was also 1 person that commented that eel catch would be better if horseshoe crab harvest were allowed in

These minutes are draft and subject to approval by the American Eel Management Board.

The Board will review the minutes during its next meeting.

New Jersey, and another said that eel catch did significantly decrease when the female horseshoe crab harvest was banned. Now we'll go over to the AP Chair for the AP report.

### ADVISORY PANEL REPORT

MR. FEIGENBAUM: On the question of the coastwide cap Issue 1, 3 of 5 AP members favored status quo, questioning how a cap reduction could be justified in an era of historic low fishing effort, and with a stock status that does not find overfishing taking place. This was the dominant position of public comments made at the state meetings.

While supporting status quo, the AP member most closely connected to the processing and export industry acknowledged that Option 5 would cause little short-term disruption. At the same time this member warned that Option 2 is draconian, and could bring an end to the commercial fishery altogether.

One of Maine's AP members expressed no position on the coastwide cap options. The AP member from the NGO sector supported Option 3 for the coastwide cap, believing that the data supports a more precautionary approach, including some data from outside the ASMFC range. On Issue 2, the APs feedback was that the panel members had no preference between the two options.

As far as the sunset date, 2 AP members spoke in support of Option 1, meaning that the cap could be updated after 3 years, based on better data and improved modeling. The other AP members offered no comment on the issue. On the issues in Option 3.3, all AP members were in favor of Option 2, making optional the collection of individual lengths and pigment stages during young of the year surveys.

The APs unanimous position is based on assurances from ASMFC that surveys would continue to distinguish the age classes being sampled. For example, whether they are really

Year 0 surveys for glass eels, or Year 1 surveys, which scientists refer to as elvers. All the commercial fishermen use the terms interchangeably. On Issue 3.4, four of the AP members favor Option 1, status quo. They cited the importance of CPUE information in assessing data-poor species. They also noted support for this position in the public comments. The AP member with the longest tenure on the panel at the meeting, noticed that the Technical Committee has previously insisted that favorable catch data may not be used as a stock indicator, unless it's accompanied by CPUE information.

They questioned how ASMFC could justify an about face at a time of historically low effort, when CPUE information provides a unique view of stock status. One AP member supported Option 2 on the grounds that it was potentially distracting from other priorities in an era of limited resources. The AP members stated unanimously that they have no strong views on Item 3.5, and support Option 2 if that is the Commission's recommendation. The AP provided some additional feedback.

During the meeting concerns were raised by at least 1 panel member, as well as a public observer representing the processing and exporting sector, about the Commission's reliance on the stock status assessment, considering that it is the third different model used for assessing eel stock in three successive assessments.

The use of fishery dependent information in this stock status without any CPUE information, especially in an era of historic low effort was the source of other questions. There was a feeling that the abundance index mis-weights fishery independent data, or over-weights fishery independent data that come from areas of commercial fishing that comprise only part of the species vast U.S. range.

It gives low data surveys equal weight to data rich surveys. Finally, pointed out that the peer review comments in three successive assessments have demonstrated in the lack of reference points, all demonstrate the limited authority of the stock

These minutes are draft and subject to approval by the American Eel Management Board.

The Board will review the minutes during its next meeting.

assessments. That is the summary of the AP comments, thank you.

MS. STARKS: Just as we just did with Addendum VI, the Board actions for consideration today are to select management measures for Addendum VII, and consider final approval.

CHAIR KUHN: Thank you, Caitlin and Mitch on those presentations. At this time, we can take questions for Caitlin on the presentation and Mitch on his report. Bill Hyatt.

MR. WILLIAM HYATT: I have a question regarding Figure 11 that was in the materials that were sent out prior to the meeting. I think this was presented as sort of a truncated bar chart in your presentation earlier. I'm looking at that and interpreting it as only Option 2 is the only option that departs from the historical harvest pattern that was associated with the depleted condition today. I just want to make sure that I am interpreting that figure correctly, if there are any nuances that I should be aware of. Thank you.

MS. STARKS: Apologies, I'm trying to find Figure 7, so I can remind myself which one it is.

MR. HYATT: It was Figure 11.

MS. STARKS: Eleven. Okay, you were asking about Option 2, correct?

MR. HYATT: Correct, yes, I am interpreting that as the only option that departs from the historical pattern of harvest that is associated with the depleted condition we have today. The only option that departs from that is Number 2, and I'm seeking any clarification. Are there any nuances that I should be aware of in my interpretation of that?

MS. STARKS: The four lines, and actually, Madeline, I think there is a slide with this on it, if you want to pull it up, just so it is clear what I am talking about. This is the figure you were

referring to. Those four lines with the different colors are the results that I-TARGET would provide if that year vertical was the final year.

The black line is the catch landings trend. But the four different lines are just different results of I-TARGET based on different configurations of the tool. The red one at the bottom, which I think is the one you were talking about that is much lower than the others. That is just the tool using the configuration from Option 2, which is 1974 to 1987, 1.24 multiplier at a 0.8 threshold.

What that is telling us is, if you use those variables in a configuration of I-TARGET, it's recommending based on the abundance index, which is not shown in this graph, that the catch in each of those years should have been much lower than the catch that was actually caught in those years.

CHAIR KUHN: Does that answer your question, Bill?

MR. HYATT: Yes, thank you.

CHAIR KUHN: Thank you for the question, and thank you for the informative answer, Caitlin. Do we have any other questions? Yes, Craig Pugh.

MR. CRAIG PUGH: I guess I can make my point through this graph, or the other three-colored bar chart that you had shown earlier. The statements were made in the Advisory Panel, and I agree with them. They are shown very plainly in the black line here with the dots. You see the reduction towards 1989, and that would include relieving us of a female horseshoe crab.

That's when that happened, that's what happened. We've moved to a male and then other baits accordingly. I think Mitch could probably confirm what I'm saying timeline wise. He's been involved with this fishery as long as I have. The baits were not quite as effective, but we still use them, tried for a few years. It didn't really work out. Catch effort has gone down. But in no case can the catch effort imply abundance through this time period. The fact of the matter is, either the market went to



hell in a hand basket, and it has, and the baits are of a degrading quality.

CHAIR KUHN: Mr. Pugh, is there a question in there, I'm sorry to interrupt.

MR. PUGH: It made the history a little tougher for us to get through.

CHAIR KUHN: We're taking questions, is there a question in there? There will be time for comments later.

MR. PUGH: Fine.

CHAIR KUHN: Question, Justin Davis.

DR. JUSTIN DAVIS: Sorry, it must be getting late in the day, I had to navigate through all the empty soda cans and water glasses to get to my microphone here. I just want to make sure I fully understand the mechanics of the I-TARGET approach, and how it's going to potentially play out in coming years.

Under Issue 3.1, issue on the coastwide cap. If we adopt today any option other than status quo, we are officially adopting the I-TARGET approach that will become part of the FMP, and we will use I-TARGET to set coastwide cap in future years at whatever interval we decide to revisit it, but we will not have an opportunity to change the configuration of the threshold and the multiplier and those values, until the next benchmark stock assessment?

Is that when there would be an opportunity to adjust those dials? I'm trying to get a sense for, you know if we officially adopt I-TARGET today, how long will we be required to use the current configuration we adopt? When will there be an opportunity to change those settings? When would there be an opportunity to stop using I-TARGET if the Board wanted to?

MS. STARKS: Yes, thank you for that question. Essentially, if any of those other options is chosen, 2 through 5, it would mean that an

Addendum would be required to change the configuration of I-TARGET, or to stop using it in the future. If there were a benchmark stock assessment in 10 years, which is recommended, and things changed and you wanted to use a different configuration or a different management tool, then you could initiate an addendum after that point, or you could initiate an addendum any time. But it would be required to change the configuration.

CHAIR KUHN: Are there any other questions? Yes, Shanna Madsen.

MS. SHANNA MADSEN: Just a quick correction. Caitlin, I verified with my staff member. I know we only had one guy at our eel meetings, and that conversation was very long. But he selected Option 3 actually, it was not Option 5. Just a quick correction on that. I wanted to let the Board know that that is what was coming out of Virginia during our public hearings.

CHAIR KUHN: Yes, Lynn Fegley.

MS. LYNN FEGLEY: Would you mind returning to Figure 11. I'm just going to ask this question, to make sure that I understand and that everybody else understands. If whichever of these levels we decide to fish at, our goal is to get to 125 percent of whatever the reference period is that we choose. My question, I want to make really sure is that if we're fishing at the particular cap. Do we know, have any idea how long it will take to get us to that 125 percent or 150 percent of the reference period? I guess that is my question in a nutshell is, do we know, do we have any means to know. The reason I ask that is because there is a phrase in the peer review report that says that the management action will not necessarily create a population response. I just want to make sure that we're all clear on what we are going to get for a management response as we make this choice.

MS. STARKS: I think like all of the species we manage; the answer is no; we can't predict exactly how management is going to impact the population. With eel, as you know, there are a number of factors that affect the population and it's

These minutes are draft and subject to approval by the American Eel Management Board.  
The Board will review the minutes during its next meeting.

coastwide stock. There are lots of things going on, and there is no population projection model.

CHAIR KUHN: Are there any other questions on the presentations, before we move into discussion? Okay, seeing none.

**CONSIDER APPROVAL OF ADDENDUM VII**

CHAIR KUHN: I'll open it up to the Board for discussion. Is there anybody that wants to discuss the presentations? Craig Pugh, do you want to finish up your thought?

MR. PUGH: Point being that the catch effort has no indicative conclusion as to abundance. If the effort is not there, how can the landings that entered into this have any meaning at all? That is as far as abundance. I guess that is my true question. Can you answer that for me, Caitlin? If there is, then that would be informative to me.

I know there has been quite a drop off in effort. But with that, we also see them in a bycatch, so a situation with our blue crab fishery that shows a heavy abundance of these, but yet we don't necessarily market them, but we see them quite often. They are a bit of a pain, because they consume our bait before the crabs do. At any rate, I guess that is more my question. Can you help me with that, because that is my conclusion, maybe I'm wrong. But if you can help me with that, I would certainly like to hear it.

MS. STARKS: Yes, I think I can help. We went back to this graph, because this is showing both the abundance index and the catch trend. Again, the catch is the black line, and that is what was on the last graph. But these two things are not related in our stock assessment model or in this I-TARGET model. But it's to show you how they line up with each other. What we were doing in the last graph is just simply showing how the actual catch would

have compared to I-TARGET recommendation of catch.

CHAIR KUHN: Yes, Russel Dize.

MR. RUSSEL DIZE: What Craig Pugh was talking about with the catch per unit effort. There is no catch per unit effort now in my area of the Bay. Everyone has had to quit, because it is very expensive to go out and try to catch eels without a market to sell them. If you look at the graph, once that graph goes down like that, that became when we could not sell the eels any longer.

You've got to look at that point. In my area, at Tilghman Island in the middle of Maryland's portion of the Bay, we had loads of people catching eels. Since, if you look at the graph and the time period. Since that happened, since we could not sell them anymore, it's gone down, because in my area we have no catch effort. Another thing, you've got to look at where the Technical Committee are getting their information. I looked into it a little bit. The four points in the Hudson River, which I can't say where they are, because I don't know. But if you go to the Hudson River and it's over a ten-year period, there may be nothing. In the set they do one in Maryland, one, and that is in the upper reaches of the Chesapeake Bay, Sassafras River. The Sassafras River is full of blue cats and snake heads, no eel, they're going to eat them up. Matter of fact, they're going to eat the rockfish up too. This whole thing is really swayed, because you can't get an accurate accounting for what is out there.

Like Craig said, we've got beaucoups of yellow eel in our area, so many that we're complaining about it in our crabbing operations. I think this whole thing has been swayed one way, several factors. Craig pointed out the bait. Another factor is, you cannot sell the eels, so you are not going to catch them.

I think in your report you said you were not going to use the CPUE anymore. If you don't use that, how in the world can you tell what is out there, if you're not going to take the CPUE from it? I just don't understand that, because we've got no one catching them. If you don't have anyone catching

them, you're not going to be able to tell what the effort was. I don't understand the whole thing. Thank you.

CHAIR KUHN: Kristen, would you like to respond to that?

DR. KRISTEN ANSTEAD: Yes, all right just one point of clarification is that you aren't being punished for the current low catches by the I-TARGET method. These recent low catches, we acknowledge that is because of market, because of COVID, because of all those things. The index is what is determining how you're adjusting your catch recommendation.

Just to make sure that is clear to the Board is, like the 2020 low catches are not driving the low recommendation. As for the indices, I totally agree with you. I would love to have more indices for eel. The TC and the SAS would love to have more to consider to put into this tool. The ones that we took to make this abundance index that you see up there, were the best indices we had available to us.

Certainly, we were not cherry picking them, and we did look into the Hudson River issue as tasked by the Board, and it does have an effect on the overall trend of this. But the Hudson River is part of the coastwide stock, and it wasn't one of the Hudson River indices driving this, they all were telling the same story. They do have an effect, but they are also part of the stock, an important part of the stock, because they provide some historical data. I hope that helps answer a couple questions.

CHAIR KUHN: Yes, Russel.

MR. DIZE: But I would like to give you a scenario. I'm on several of the oyster we use on panels in Maryland. Also, Captained the Skip Jack, ran the Skip Jack for 28 years. If you go out dredging oysters, and you go on the oyster bottom. But I can take you to a thousand places where there is neither oyster, not one.

I say you should be taking your feedback where you're testing. If you feel you're not getting any, try something different. I mean I would fail as a waterman if I went out and it did the same thing every time, and you kept going down. I mean it doesn't make sense. If you come to the middle of the Chesapeake Bay, down into our area, you're going to find beaucoups of yellow eel. But if you never test it, you're never going to see it. We can't prove it now, because we can't sell the eels. It's a no-win situation. I just think that this is a flawed scenario from start to finish. I'm very unhappy with it. Thank you.

CHAIR KUHN: Thank you for your comments and perspective, Mr. Dize. John Clark.

MR. JOHN CLARK: Yes, Mr. Chair, are you ready to start considering motions on this?

CHAIR KUHN: I was about to if there was no more discussion, but I did see one more hand here before yours, Shanna Madsen, and then we'll go into entertaining motions.

MS. MADSEN: It's just a quick, clarifying question, because I've heard this misconception a lot of times when discussing I-TARGET. Dr. Anstead, correct me if I'm wrong, but the current catch levels are not what is being considered in I-TARGET, or referenced in I-TARGET. You are actually referencing back to the average catch during the reference period, so I-TARGET isn't working in those periods of low catch that people are concerned with.

DR. ANSTEAD: That's correct. The significance of choosing a reference period is you are choosing the average catch during that reference period. If you use the older reference period, your average catch during that earlier period gets adjusted by the fishery independent index. We don't have any fishery dependent CPUEs in here. Depending on where your current index is, compared also to that reference period, is how it's adjusting that historic catch to make a catch recommendation.

CHAIR KUHN: Thank you for that question and explanation. I think we're at the point here where

we are exhausting our discussion, so let's go ahead and get into motions. I know John Clark had tried to offer one previously, so go ahead, John.

MR. CLARK: I don't think anybody will be surprised, considering the comments I've made about this Addendum in the past that I would **move to approve under 3.1, Issue 1, Option 1 that we go with status quo**. If I can get a second, I can speak to that.

CHAIR KUHN: Do we have a second? Russel Dize. Okay John, can you speak to that motion.

MR. CLARK: There are a bunch of reasons here. I think not just the fact that anybody who has fished commercially for eels, as mentioned as Craig and Russel have, that the yellow eel stock in the areas where it is fished, where the fishery is, is in very good shape. But I want to consider all the points here, so defining the stock as overfished was rejected by the Peer Review.

I appreciate all the work the Stock Assessment Subcommittee put into this, but the fact that when the assessment came out it was actually recommended, considering the stock overfished I thought was a gross overreach, and I was very heartened to see the Peer Review reject that, and continue the depleted. You know as we saw from 2019 to 2022 catches drop from 60 percent of the cap to 35 percent of the cap. I mean this is a market driven fishery. I would say, I know that Russel and Craig had spoken about the catch per effort being the problem. I think what it actually shows, when we look at what has been going on out there. I look at Delaware, where Craig said because of the lack of bait we've had a huge drop off in effort. We've had new people come in, they are not using as good a bait, but there are plenty of eels out there, because our catch per effort every year, which is not used in the assessment, has remained steady.

We also want to look at the attempts to link eel declines the parts of its range to overall declines

in the population that haven't occurred. Before I was a fish bureaucrat, I was actually a field biologist, and I worked with eels a lot. I did a lot of onboard sampling with commercial eelers, and I think that the eel biology, especially in the estuaries where the fishery is prosecuted, as I've said before, is very unique.

I could be out, you know we would go into a small gut, put out four or five pots, you would load up with eels. You might get that for two or three days, after that they're gone. You pull the pots. You leave it alone for a couple of weeks, you come back, the eels are back. It's just the way it is in the estuaries, the eels there don't stay very long there.

They pretty much mature. We rarely see eels older than five or six years old, whereas the eels that made it inland, like the huge eels they see in Lake Ontario. I mean that was a 20- to 30-year-old eel. Back when this whole process started to manage eels, the concern was that the extirpation of eels from Lake Ontario was the signal that the species was going extinct.

We haven't seen that happen. I think the indices in the Canadian Maritimes have been steady. What they're seeing up in Maine with the life cycle study, which is again at the northern end of the range, shows that there are still plenty of yellow eels out there. I wanted to point out in the assessment that the only survey that targets eels with eel gear actually showed a significant increase.

This is the Maryland survey that takes place in the Sassafras River. Even the decline mentioned for the stock, using the MARSS model, it said it straight in the stock assessment that although the MARSS model fit the yellow and young of the year time series suggested a slightly declining population, the 95 percent confidence intervals on population growth rate estimates overlap zero, suggesting a stable population.

You know we would be taking a very harsh measure here, I think, based on not too much. I think the whole I-TARGET method is almost as arbitrary as using the cap we have now, which is based on

These minutes are draft and subject to approval by the American Eel Management Board.

The Board will review the minutes during its next meeting.

landings. I don't see, you know we're going from one form of expert opinion to another form of expert opinion.

This one tries to objectify it a little bit more, but it's essentially that. Just got a couple more points here, so please, bear with me. I would say that separating the yellow eel and considering it overfished, or trying to reduce the cap, while leaving the glass eel quota status quo, is almost a cognitive dissonance here.

I mean you need yellow eels to go out and reproduce to produce glass eels, obviously. If there are plenty of glass eels out there, clearly the stock is doing something right to keep producing that. Even though in Delaware our catches have really dropped off. We're not the major player in eels that we were 15, 20 years ago, and mostly as Craig said, because of the female horseshoe crabs, which of course is another fraught issue. The fact is, is that lowering the cap will lead to bureaucratic burdens, and make it more difficult for the future of the people that want to get into this fishery. One of the things that is nice about eels in Delaware and other states, is it's an easy fishery to enter. It's pretty low capital investment to get started.

Every time we make one of these fisheries more difficult for young people to get into, you know we've got to start thinking about the next generations of commercial fishing, and give them some options to get into this that don't require them to try to get a gillnet license or a crabbing license transferred to them that could end up costing a lot of money.

I think for all those reasons, I certainly understand the work done and the trends with eels with the population. It would have been nice to see the population show some increases by now, but the fact is that it is basically holding stable. We have a market driven fishery that I'm mostly saying here, it's not broken let's not fix it. I'll just leave it at that for now.

CHAIR KUHN: Thank you, John, appreciate the detailed rationale for the motion. Given the thoroughness of your response and your rationale, I'll still go to Russel Dize to see if you want to add anything additional that is new to what John had just said.

MR. DIZE: I agree with everything John said. But I have a note here that in 2022, 300,000 pounds of glass eels were sent into Hong Kong. We had better get a handle on what's happening, because it is my understanding, and Ms. Starks can keep me straight on it, that all eels spawned in the Sargasso Sea, right?

If they all spawn there, that means that is 300,000 pounds of glass eels, and every pound of glass eels have 2,000 eels in it. Do the figuring on it. This is what is coming out. Where they're coming from, I don't know, but we should try to find out. I know that Haiti didn't catch 200,000 pounds of glass eels last year. That is what they say they caught. It's coming from somewhere else, and it would behoove us to find out where they are coming from for the industry to survive.

CHAIR KUHN: Appreciate those comments, so let's stay focused on the motion here with yellow eels. We heard the rationale, so I'll open it up for discussion on the motion. Justin Davis.

DR. DAVIS: I guess we might as well paint the corners here. I'm going to offer up a **substitute motion**, and that would be **to move to approve under 3.1, Issue 1, Option 2 coastwide cap set at 202,453 pounds** using the I-TARGET configuration recommended in the 2023 benchmark stock assessment.

CHAIR KUHN: Do we have a second? Rick Jacobson. Okay, Justin, would you like to provide rationale for your motion?

DR. DAVIS: Sure, thank you, Mr. Chairman. From my standpoint, I think the Board has two decisions in front of it today, the first being whether we want to adopt the I-TARGET approach for management, and if we do, what sort of settings we want to use

These minutes are draft and subject to approval by the American Eel Management Board.  
The Board will review the minutes during its next meeting.

for the I-TARGET. Then given the depleted state of the stock, whether we want to take action today that is likely to provide conservation benefit in the immediate timeframe. For my standpoint, I think we should adopt the I-TARGET approach for management. I like it because it formalizes our goals and what we're trying to achieve, and provides a clear pathway for what to do to get to those goals. I think it makes the best use of the available information we have for this data poor species.

I think the settings recommended in Option 2 are appropriate. I think it's the appropriate reference period, that older time period, when it is obvious abundance was much higher. The multiplier, I like the 1.25 because it's not setting the goal too high, but the threshold is conservative at 0.8, so it suggests that we'll be conservative at least in the near timeframe to try to achieve that goal. From my standpoint also, of the options in front of us here, Option 2 is the only one that is likely to achieve conservation in the near term for this species that is depleted.

I can understand the viewpoint that because we don't have a robust stock assessment model that gives us estimates of biomass and reference points, and tells us you know what F is, and how F is impacting our ability to get those reference points. You know the stock is depleted. I think it is in need of conservation, and I think we should take action today that is likely to provide that conservation in the near term. For those reasons I support Option 2.

CHAIR KUHN: Thank you for that rationale. Rick Jacobson, the seconder, would you like to provide some additional rationale?

MR. RICK JACOBSON: I agree with everything that Dr. Davis has just said. Specifically identifying that the Peer Review did agree with the Working Group that the stock is in fact depleted. I also acknowledge that the Peer Review group, although at the timing by virtue

of the I-TARGET we could not conclude that the stock was overfished.

It also did not conclude that the stock was not overfished. It may in fact be. We strive to make our management decisions based on the best available science. However imperfect it might be, the I-TARGET approach does represent the best available science to us, and as a result of that, Option 2 represents the recommendation coming out of the I-TARGET that has the most likely opportunity to rebuild the stock, and that is why I am in favor of it.

CHAIR KUHN: Discussion on the substitute motion. Lynn Fegley.

MS. FEGLEY: I absolutely oppose this motion. I hope that the Board has heard a little bit what my colleagues who commercially fish for these animals around the table are saying. This is a really difficult problem, and I think everybody around the table would acknowledge that there are issues with American eel, and it needs some attention.

But I think everybody would also acknowledge, particularly in light of Option 2, that we are in a state right now where carrying capacity has changed. There are so many factors around us, particularly for American eel. Everything from habitat degradation, fish passage, climate change, that I just don't even know that it is realistic to think that we're going to get back to 1999. If I could get back to where I was when I graduated from high school, in a lot of ways I would be really excited about that. But it is not going to happen, and I don't mean to make light of it. But I think it's really important to, if we're going to take action on this animal, to set our goals in a reasonable way that are attainable, particularly because with this method, we really don't know that these catch targets are going to get us to where we want to go.

I think the I-TARGET is clever, but at the end of the day we're arguing over about 400,000 pounds of eel, and there are a lot of places where we could focus our attention, and maybe make a difference. I think it's also worth noting. You know one of my

issues also is that the terminal year for this is 2019, so we're in 2024.

We have basically been sort of doing this moratorium experiment for the last three years. You know we've been fishing at very low levels, and frankly I would like to see what those catch targets would look like. I would like to see the indices in the last three years, and see what those look like.

To just bring a finer point on it, that terminal year seems to coincide very well, coincidentally, with when the market fell out. That is really hard for our commercial fishermen in Maryland to wrap their heads around. You know this is a group of people who voluntarily took action a number of years ago, to curtail Maryland's harvest, to make sure that we were not going to exceed the cap.

I mean they really care about this resource. They are not catching the eels right now, so really, we're talking about removing opportunity more than revenue. But I'm a little uncomfortable. I fear that this sort of management that is a little bit nonsensical from the ground. I oppose this motion, thank you for hearing me out.

CHAIR KUHN: I saw Shanna Madsen.

MS. MADSEN: I'm going to kind of discuss both motions now they are up there. I would not support either of these motions. I was looking for a motion on Option 3. I believe that Option 3 affords us a lot of flexibility that the SAS and the Peer Reviewers actually allowed. In going back to the reports, the Peer Reviewers and the SAS noted that they really did not know what level to set the threshold at.

They begged us to keep the reference period, and they begged us to keep the multiplier. But they said, you can vary the threshold, because we don't know exactly what that threshold should be. For me, I would prefer to go with a less conservative threshold, which gives a nod

to my compatriots a little bit north of me, in that we're saying, we recognize this is a depleted stock, it is not an overfished stock. I understand the difference there, Mr. Jacobson, I see you over there.

But I think that setting to a higher threshold still curtails what the opportunity might look like. I also think that with any fishery you have that uncertainty of not knowing whether or not the actions that you take are going to result in an actual change in the index or in the fishery. But that doesn't mean we don't do them. With a stock that is depleted, I would have to say that I would support Option 3, just to kind of try to find some sort of balance in here and still have an I-TARGET that was recommended by the SAS and the Peer Reviewers. Thanks.

CHAIR KUHN: Thanks for that, Shanna. We've heard two in opposition, the maker and seconder provided rationale for the motion. At this point I think we're ready to call the question. Is there a need to caucus? All right, two minutes for caucus. Okay, two minutes are up. Where we are in the agenda right now is that I am not going to accept public comment on this motion at this time. We had a hearing on it, and we received public comments in written format. I would like to call the question. **All those in favor raise your hands.**

**MS. TONI KERNS: Connecticut, U.S. Fish and Wildlife Service.**

**CHAIR KUHN: All those opposed.**

**MS. KERNS: Sorry, and NOAA Fisheries. For opposed it is Rhode Island, Massachusetts, New York, New Jersey, Pennsylvania, Florida, Georgia, South Carolina, North Carolina, Virginia, District of Columbia, Maryland, Delaware, Maine, New Hampshire. Plus PRFC, sorry.**

**CHAIR KUHN: Any null votes? Abstentions? The motion fails 3 to 16, so now we're back to the main motion.** Shanna Madsen.

MS. MADSEN: I would like to make another motion to substitute. **Motion to substitute to replace**

These minutes are draft and subject to approval by the American Eel Management Board.

The Board will review the minutes during its next meeting.

**under Section 3.1, Issue 1, Option 3, the coastwide cap being set at 518,281.**

CHAIR KUHN: Do we have a second? Dan McKiernan. Okay, Shanna, would you like to provide some rationale in addition to what you had already provided on previous comments.

MS. MADSEN: Yes, I'm going to keep it short, since I already spoke to this. Again, I think that it is really important for us to be listening to the staff and the TC here. They have an entire section in one of the documents that they asked for from us regarding the fact that this is not how we normally respond to a stock being depleted.

Most of our depleted stocks actually have a moratorium. But again, recognizing that we're in a place where there has been some question about what the fishery is doing. I am comfortable with varying the threshold, which is what the SAS and the Peer Reviewers recommended if we wanted some flexibility.

CHAIR KUHN: Dan, any additional rationale? No, okay, discussion on the motion. Yes, Steve Train.

MR. STEPHEN TRAIN: I can reluctantly support this motion. I would rather have seen the original or Option 5, and let me explain this. It's not the eels I'm worried about it's the fishermen. I am a commercial fisherman; I understand fisheries behavior. Fishermen worry that they are being punished for not catching eels.

If this quota gets dropped too low versus staying where it was. If it stayed where it was, they would continue to fish to what the market needed. We might not land much. If they are worried, they are going to lose quota because they didn't land enough eels, they will catch 519,000 pounds. If it were 700,000 or 900,000, they might only catch 3. I worry that if you really want to protect the eels, you don't want to cut it low enough that they max it out. If this

is what we're going to get to allow this fishery to proceed I could support it, but I'm worried it's going to backfire.

CHAIR KUHN: Lynn Fegley.

MS. FEGLEY: I just didn't quite get my hand up fast enough. I would actually speak in opposition of this motion, mainly because, and I understand the reference period. But I have absolute concern. I would prefer to use the same criteria for I-TARGET, and set the reference period to that more recent reference period, because I believe it more reflects the ecological state of our world, and it's a more realistic goal, and that would be Option 5. I feel like that is something we can set our sights on.

Dr. Davis made the point that it formalizes our goal, it formalizes where we want to get to. It accommodates Mr. Train's comment about really treating this carefully. You know again, we're talking about opportunity, we're not talking about catch right now, and the perception that it is penalizing commercial fishermen for a catch, and this sort of disconnect in the life cycle of the animal. I would really like to see us get a handle on glass eels, and finally, I would really like to see the index of results for the last three years before it moved off the quota beyond that Option 5.

CHAIR KUHN: I saw a hand from Joe Cimino.

MR. CIMINO: I'm going to speak in favor of the motion. You know this is, I think a species with a life cycle that makes this tough to manage. But some of the comments around the table have really concerned me. We've all sat through the very important Climate Scenario Planning, and moving into greater uncertainty is very likely the future of fisheries management.

We're going to have to make tough decisions, and I think this is one where we're trusting the folks that have spent the most time looking at this, and giving the best available science and advice that they can on this, while still balancing the socioeconomic issues. I mean some of the conversations around the table sound like people are ready to hang up

These minutes are draft and subject to approval by the American Eel Management Board.  
The Board will review the minutes during its next meeting.



their spurs and just give up, because we don't have great information.

But unfortunately, if we're going to sit around this table, we're going to have to make these tough decisions. I think this is the best balance, and the reason why I'm really supporting it is because I am trusting the folks that put in so much time and effort on this, and trying to support them and where they think we should go.

CHAIR KUHN: I saw a hand from Jesse Hornstein.

MR. JESSE HORNSTEIN: I want to speak in support of this motion. I think this is the right balance for this option. You know currently commercial harvest is about 350,000 pounds, so this option allows the commercial fishery to grow, should market conditions improve in the future. But it sets the cap at a level that is not three times or greater than what is recommended in the assessment, so it's a nice balance between the two. Option 2 would potentially shut down the fishery, and I think Option 5 or the status quo option would just potentially put the stock at further risk of depletion if those options were selected.

CHAIR KUHN: John Clark.

MR. CLARK: I'm opposed to this motion. Obviously, I spoke in favor of status quo. One of the things we keep talking about, best available science, one of the things I find extremely frustrating is that I've been either on the TC or on the management board on eels since 1997. Every time an assessment comes up it's like, okay, well we don't have data to say more than this limited amount about it.

We have these surveys, these fishery independent surveys, most of them which are not designed to catch eels, and they are limited in their appropriateness for using for eels, I think. You know every time it's like, well states need to go out and get more data. It doesn't

happen and we end up in this feedback loop where it's depleted.

We should do something. I mean we did something with the cap, which was based on the empirical data that we had from the fishery itself. We have taken actions based on the coastwide cap we have in place. I think if states are really that concerned about eels, they should look into doing more work on this.

I mean we're one of the few states that has consistently gone out and gotten otoliths from eels, gone to the commercial fishermen and seen what they are doing and gotten their samples of eels to get the data that is needed for these things. It's not done throughout the range. As I have said before, I think right now we have almost two different populations of eels.

I think eels, especially the further they get from the coast, these eels are having very huge difficulties. I mean as we've seen what has happened in Lake Ontario, whereas in the estuaries, especially the two where they are probably the biggest eel fisheries in the Delaware Bay and the Chesapeake Bay. The eels seem to be doing fine.

Now again, is that something that would allow us to just keep fishing the way we've been fishing? I think so, at the current levels that we're seeing, even up to the cap. I don't think that is going to be a problem. But that is my opinion, and I just wanted to weigh in that I'm just a little, to say that this is the best science when we just have five more years of the same stuff every time the assessment takes place.

CHAIR KUHN: We've had considerable discussion on this motion. Is there a need to caucus before we call the question? Seeing none; **we'll go ahead and call the question. All those in favor.**

**MS. KERNS: Rhode Island, Massachusetts, Connecticut, New York, New Jersey, U.S. Fish and Wildlife Service, Pennsylvania, North Carolina, Virginia, District of Columbia, New Hampshire and NOAA Fisheries.**

These minutes are draft and subject to approval by the American Eel Management Board.  
The Board will review the minutes during its next meeting.

**CHAIR KUHN: All those opposed.**

**MS. KERNS: Florida, Georgia, South Carolina, Potomac River Fisheries Commission, Maryland, Delaware, Maine.**

**CHAIR KUHN: Any null votes, abstentions? The motion passes 12 to 7, so the motion now becomes the main motion.** We've had considerable discussion on this, is there a need for any additional discussion or a need for caucus, before we decide upon this motion that is on the board now? Lynn Fegley.

MS. FEGLEY: I'm just going to try it. I'm going **to move to substitute the main motion for Option 5.**

CHAIR KUHN: I'm sorry, I couldn't hear that, was that Option 5?

MS. FEGLEY: Yes, I second guessed myself, but yes, Option 5.

CHAIR KUHN: Do we have a second? Steve Train. Lynn, do you want to provide additional rationale from what you've already provided for your support for Option 5?

MS. FEGLEY: No, thank you, Mr. Chair, I've said all I can say.

CHAIR KUHN: Mr. Train.

MR. TRAIN: I think I explained my rationale for that on the last one.

CHAIR KUHN: Any discussion on the substitute motion? Adam Nowalsky.

MR. ADAM NOWALSKY: I would like to add that while I disagree with my state commissioners to my left on the last motion. I completely agree with the comments that Mr. Cimino made that we should listen to the people that know the most about this resource. I say that without any disrespect to the hundreds or thousands of hours of research, model work that has gone

into this, because they are doing the absolute best that they can.

But I can say this with almost 100 percent certainty, that the two people sitting around this table that know the most about the health of this resource, Mr. Pugh and Mr. Dize. I have no qualms sitting here today saying that to make a management decision based on industry making sacrifices on their own in the past.

Having their bait taken away from them, having their market taken away from them, and for us to respond to that by further punishing them and taking away opportunity, sends a completely wrong message of everything that we are here to do, in terms of both managing the resource, as well as being good stewards of the public that we are sent here to represent.

CHAIR KUHN: Any additional discussion on the substitute motion? Any need to caucus before we call the question? Seeing none; we'll get right to it. **All those in favor, please raise your hands.**

**MS. KERNS: New Jersey, Georgia, South Carolina, Potomac River Fisheries Commission, Maryland, Delaware, Maine.**

**CHAIR KUHN: All those opposed.**

**MS. KERNS: NOAA Fisheries, Rhode Island, Massachusetts, Connecticut, New York, Fish and Wildlife Service, Pennsylvania, Florida, North Carolina, Virginia, District of Colombia, and New Hampshire.**

**CHAIR KUHN: Any null votes, abstentions? The motion fails 7 to 12.** Now we're going to go back to the underlying motion, which is Option 3. Do we have a need for any discussion? Caucus? Seeing none; **we'll go ahead and call the question for Option 3. Have that up on the board. Okay, all those in favor for the motion up on the board, Option 3, raise your hands.**

**MS. KERNS: NOAA Fisheries, Rhode Island, Massachusetts, Connecticut, New York, New**

These minutes are draft and subject to approval by the American Eel Management Board.  
The Board will review the minutes during its next meeting.

**Jersey, Fish and Wildlife Service, Pennsylvania, Georgia, South Carolina, North Carolina, Virginia, District of Colombia, Maine, New Hampshire.**

**CHAIR KUHN: All those opposed.**

**MS. KERNS: Delaware, Maryland, Potomac River Fisheries Commission, Florida.**

**CHAIR KUHN: Null votes. Abstentions. The motion passes 15 to 4.** Okay, so we still have a number of decision points that we have to come here to today, regarding the items that were covered in the presentation. I'm going to get right to asking for if anybody has any motions regarding the management response to exceeding the coastwide cap.

The timeframe for how long the selected coastwide cap would remain in place, annual young of year abundance survey requirements, catch and effort monitoring requirements and American eel de minimis criteria. Feel free to wrap some of those into a single motion if you so choose. Yes, Lynn Fegley.

MS. FEGLEY: I have a motion, and I'm going to grab two issues together, one is a little bit out of order, but they both apply a little bit to the status quo issue, so the **motion is to approve for Section 3.1, Issue 2, Option 1, which is the status quo that states over 1 percent of the coastwide landings will participate in the reduction, and then also to approve for Section 3.5, Option 2, which is that we will use the 3-year landings average for de minimis.**

CHAIR KUHN: Do we have a second? John Clark. Lynn, would you like to speak to that motion?

MS. FEGLEY: Just these are consistent with the Commission's de minimis policy. I think they're clear, I don't have a lot to say, except that they are straightforward and seem appropriate.

CHAIR KUHN: John Clark as seconder.

These minutes are draft and subject to approval by the American Eel Management Board. The Board will review the minutes during its next meeting.

MR. CLARK: What Lynn said.

CHAIR KUHN: Okay, any discussion on the motion? Yes.

THAD ALTMAN: Our fishery is very market driven and quite variable, so with the reduction with this motion if it should pass, reducing the catch we feel like might be more appropriate to increase, instead of going to the greater than 1 percent the 5 percent, so Florida would be opposed to this.

CHAIR KUHN: Any additional discussion? Yes, Chris Batsavage.

MR. CHRIS BATSAVAGE: North Carolina is in a very similar situation with Florida regarding the 1 percent threshold.

CHAIR KUHN: Further discussion? Okay seeing none; is there a need to caucus? Seeing none; **go ahead and call the vote. All those in favor.**

**MS. KERNS: Rhode Island, Massachusetts, Connecticut, New York, New Jersey, Pennsylvania, Georgia, South Carolina, Virginia, District of Colombia, Potomac River Fisheries Commission, Maryland, Delaware, Maine, New Hampshire.**

**CHAIR KUHN: All those opposed.**

**MS. KERNS: Florida, North Carolina.**

**CHAIR KUHN: Null votes, abstentions.**

**MS. KERNS: NOAA Fisheries and Fish and Wildlife Service.**

**CHAIR KUHN: The motion passes 15 to 2 to 0 to 2.** We still have a few items here to deal with, the timeframe on how long the selected coastwide cap would remain in place, as well as annual young of year abundance and catch and effort monitoring requirements. I see Shanna Madsen; do you have a motion?

MS. MADSEN: I do. I have **move to approve under Section 3.2, Option 1, a 3-year coastwide cap duration.**

CHAIR KUHN: Do we have a second? John Clark. Shanna, rationale.

MS. MADSEN: My rationale here is three years was kind of deemed appropriate by the SAS as a time for us to come back to the table and reassess what is going on with this stock. They didn't want anything shorter. But this tells us, I think an appropriate amount of time whether we have good news or bad news. I think it is important for us to have that check in every three years.

CHAIR KUHN: John.

MR. CLARK: Yes, I agree that the sooner we can check this again the better.

CHAIR KUHN: Any discussion on the motion? Is there a need to caucus? Okay, again seeing none, we'll go ahead and call the question. **All those in favor, please raise your hands.**

**MS. KERNS: NOAA Fisheries, Rhode Island, Massachusetts, Connecticut, New York, New Jersey, Pennsylvania, Florida, Georgia, South Carolina, North Carolina, Virginia, Potomac River Fisheries Commission, D.C., Maryland, Delaware, Maine, New Hampshire.**

**CHAIR KUHN: All those opposed. Are there any abstentions?**

**MS. KERNS: Fish and Wildlife Service.**

**CHAIR KUHN: The motion passes 18 to 0 with 1 abstention.** Okay, so we're getting there. We still need to address the annual young of year abundance and survey requirements, as well as catch and effort monitoring requirements. Jeff Kaelin.

MR. JEFFREY KAELIN: I would **move to approve for Section 3.3, Option 1 and for Section 3.4, Option 1, status quo.**

CHAIR KUHN: Do we have a second? Lynn Fegley. Jeff, would you like to speak to that?

MR. KAELIN: Well, we're clearly in a very data poor situation with this fishery, and I can't see relaxing the requirements to continue to bring information to the table, particularly from the fishery dependent side of the equation. That is my rationale.

CHAIR KUHN: Lynn, no follow up? Okay, I see John Clark's hand up.

MR. CLARK: Yes, I would just like to make **a motion to amend on Section 3.3. I think at this point we can go with Option 2.** I know from doing much of the pigmentation staging and the sampling of glass eels over the year, it's pretty much the same thing year in year out sampling. I think we've got plenty of data from that. I don't think we need to do that, whereas I fully agree with Section 3.4 that we want to keep getting the catch per unit effort data. If I can get a second on that.

CHAIR KUHN: We have a **motion to amend the substitute**, second from Doug Grout. John, would you like to provide some rationale?

MR. CLARK: I think I jumped the gun and just did.

CHAIR KUHN: Additional rationale we'll say. None. Doug. Okay. Any need for discussion on the substitute motion or the motion to amend the substitute, rather. Okay, seeing none need to caucus? Okay we'll go ahead and call the question. **All those in favor raise your hands. All those opposed, abstentions. Any null votes? The motion passes 14 to 2 to 1 to 0, sorry with 1 abstention. Emerson.**

**MR. EMERSON HASBROUCK: Yes, we had our hand up late here, because we were still caucusing, so where did you have New York on this?**

**CHAIR KUHN: Just go ahead and tell us what your vote is. We didn't capture that.**

**MR. HASBROUCK: We would be in favor of it.**

**CHAIR KUHN: The motion passes 15 to 2 with 1 abstention. Okay, bear with us, we have a slight correction to the tally, so it's 16 to 2 with 1 abstention. Motion passes.** Okay, so now we're at, this becomes the main motion. Chris Batsavage.

MR. BATSAVAGE: I'm not going to offer a motion to amend or substitute, so they didn't count the votes in my head, but to speak in opposition to Option 1 for Section 3.4. We would prefer it be voluntary collection of fisheries dependent CPUE information as it was stated in the document that this has not been used really for any of the assessments. I think it does help inform management in some states, and those states can certainly continue to collect that information.

Just speaking from North Carolina's perspective. We do collect that information, it's probably more trouble than it is worth, quite frankly, in terms of just the administrative work to collect this information from what is left of our eel fishery. It would definitely speed up the process for our staff to get compliance reports in and other things like that. But yes, at least voice my opposition. I don't think other people will feel the same way as us, but at least get it on the record. Thanks.

CHAIR KUHN: Dan McKiernan

MR. MCKIERNAN: I would like to speak in favor of the motion, specifically reflecting the report that Caitlin gave yesterday about horseshoe crab use in some of these fisheries. I think it's important for us as fisheries managers to understand the waxing and waning effort levels in fisheries that use horseshoe crabs. That's why I would like to support this.

CHAIR KUHN: Okay, moving this along. Is there a need to caucus before we call the question? Okay, I think we're ready to do so. **All those in favor, please raise your hands. You may lower your hands. All those opposed. Any abstentions? Null votes, no, so the motion passes 18 to 1.** Okay, just checking with Caitlin and Kristen.

I think we've covered everything we needed to. Is there anything there before we get the final approval? We've covered what we need to do, so at this time we're ready to consider final approval of Addendum VII. Is there anyone willing to make a motion for that? Emerson Hasbrouck. Do we have a second? Roy Miller. Emerson, would you like to speak to the motion?

MR. HASBROUCK: I'll read it into the record first. **Move to approve Addendum VII to the American Eel FMP, as modified today.** I don't have anything to add, other than all the discussion that we've had this afternoon around this. I think we ended up in a compromised position.

CHAIR KUHN: Roy Miller. Any comments?

MR. ROY W. MILLER: Nothing further.

CHAIR KUHN: Yes, Doug Grout.

MR. GROUT: Just a question. Do we have to put in some dates for compliance at all, or does that come after we approve this?

MS. STARKS: You could do it as part of the same motion or afterwards.

CHAIR KUHN: Is there a need to caucus? Seeing no need to caucus, **is there any opposition to the motion? Okay, seeing none, the motion passes by Board consent.** We now need to set implementation dates. Is there anyone willing to make a motion regarding implementation dates? Lynn Fegley.

MS. FEGLEY: Just at the risk of maybe being a little tired at the end of the day, I'm just curious how we implement something that isn't actually happening.

These minutes are draft and subject to approval by the American Eel Management Board.  
The Board will review the minutes during its next meeting.

But it's because we're not catching, we're not coming close to the cap. I guess it wouldn't be reasonable to implement it for the next fishing year.

MS. STARKS: I think I can try to help. If you were to make it effective immediately, I think that would mean this year you would have to have that cap in place, and then if you want to have it for the following fishing year, I think you would want it to be in place for January 1.

MS. KERNS: I guess you all can also consider that if the quota is going to be effective for next year you would say January 1 for the quota provisions, and if you wanted the sampling provisions to be effective for this year, then you could say those would be effective immediately.

CHAIR KUHN: In light of the guidance provided by Caitlin and Toni, is there a motion to set implementation dates? John Clark.

MR. CLARK: I would prefer to **set the implementation date as January 1, 2029, I mean 2025.**

CHAIR KUHN: Do we have a second? Joe Cimino. Any discussion on the motion? We'll give it a minute until it comes up on the board. Okay, the motion is up on the board, which is **Move to approve an implementation date of January 1, 2025.** Motion made by Mr. Clark, seconded by Mr. Cimino. **Is there any opposition to the motion? Okay, seeing none; the motion passes by Board consent.**

**MS. KERNS: Chris, do you have your hand up in objection?**

**MR. CHRIS WRIGHT: Yes, I think it should be implemented this year, so I vote no.**

**MS. KERNS: Okay, thank you.**

**CHAIR KUHN: Okay, since we have opposition, I'm going to ask for a raise of hands of everyone that is in favor of the motion. Please**

**raise your hand. Okay, motion passes 18 to 1.** Bear with us, I think we're getting there. Caitlin would like to make one point of clarification before we move on.

MS. STARKS: I just want to make it clear that with this implementation date that means we will provide an updated cap for consideration before 2028. In 2027, we will rerun it with the three years of data that we have additional, and then provide a recommendation for 2028.

CHAIR KUHN: Okay, moving on.

#### **ELECT VICE-CHAIR**

CHAIR KUHN: The next item on the agenda is to elect the Vice-Chair for the American Eel Management Board. Do I have any nominations? Joe Cimino.

MR. JOE CIMINO: I would like to **nominate Jesse Hornstein from New York for the American Eel Management Board Vice-Chair.**

CHAIR KUHN: Do I have a second? Lynn Fegley. Any discussion around the motion? **Is there any opposition to the motion? The motion passes by Board consent,** so welcome Jesse Hornstein.

#### **OTHER BUSINESS**

CHAIR KUHN: At this point we're ready to entertain any other new business. Toni Kerns.

#### **CITES UPDATE**

MS. KERNS: I think it was Russel earlier that had asked the question about the glass eels that are showing up in Hong Kong. I just wanted to let the Board know that Caitlin and I provide information for CITES reports that do go out. We provide the information on what the U.S. landings are. But in those CITES reports, oftentimes the United States gets accounted for a higher value of landings than what is actually coming out of the U.S.

It's just that because the eel transfer through a flight through the United States, sometimes we get

These minutes are draft and subject to approval by the American Eel Management Board.  
The Board will review the minutes during its next meeting.

credited for those landings, even though they may be coming from Haiti or Costa Rica or the Dominican Republic, or anywhere else. We keep making recommendations that there is a start to finish tracking of where those eels are coming from to CITES.

(Whereupon the meeting adjourned at 5:00 p.m. on Wednesday, May 1, 2024)

We don't sit on CITES as the Commission. NOAA Fisheries does for the U.S. Government, I believe it is NOAA that does. We make those recommendations and we will keep doing so, but just to clarify some information on where those yellow eel are coming from. Those reports do come out of CITES, or glass eel, sorry. That's all.

CHAIR KUHN: Thank you for that, Toni. Roy Miller.

MR. MILLER: Mr. Chairman, I noticed when going through the meeting materials that there was a publication called Early Warning of an Upsurge in International Trade in the American Eel by Shiraishi and Kaifu, a publication that I found an apparent mistake in the first paragraph, because it says American eel, *A. rostrata* are classified as endangered. To the best of my knowledge, they have never been classified as endangered. I just wanted to point that out, thank you.

CHAIR KUHN: Yes, thank you for that point of clarification, and Caitlin has a response to that as well.

MS. STARKS: In that article it is referring to the IUCN classification, it is not classified that way in the United States, but IUCN does classify it that way.

#### **ADJOURNMENT**

CHAIR KUHN: Okay, I think that gets us to the end of our business. I appreciate everyone's participation this afternoon. Do we have a motion to adjourn? Second. This meeting is adjourned, thank you.

These minutes are draft and subject to approval by the American Eel Management Board.  
The Board will review the minutes during its next meeting.

# ATLANTIC STATES MARINE FISHERIES COMMISSION

## REVIEW OF THE INTERSTATE FISHERY MANAGEMENT PLAN

### AMERICAN EEL *(Anguilla rostrata)*

2023 FISHING YEAR



Prepared by the American Eel Plan Review Team

October 2024



Sustainable and Cooperative Management of Atlantic Coastal Fisheries



**REVIEW OF THE ASMFC FISHERY MANAGEMENT PLAN AND STATE COMPLIANCE FOR  
AMERICAN EEL (*Anguilla rostrata*) FOR THE 2023 FISHERY**

**Management Summary**

<u>Date of FMP approval:</u>	November 1999
<u>Addenda:</u>	Addendum I (February 2006) Addendum II (October 2008) Addendum III (August 2013) Addendum IV (October 2014) Addendum V (August 2018)
<u>Management unit:</u>	Migratory stocks of American Eel from Maine through Florida
<u>States with a declared interest:</u>	Maine through Florida, including the District of Columbia and the Potomac River Fisheries Commission
<u>Active committees:</u>	American Eel Management Board, Plan Review Team, Technical Committee, Stock Assessment Subcommittee, and Advisory Panel

**I. Status of the Fishery Management Plan**

The ASMFC American Eel Management Board (Board) first convened in November 1995 and finalized the Fishery Management Plan (FMP) for American Eel in November 1999 (ASMFC 2000).

**GOAL**

The goal of the FMP is to conserve and protect the American eel resource to ensure its continued role in the ecosystems while providing the opportunity for its commercial, recreational, scientific, and educational use.

**OBJECTIVES**

1. Improve knowledge of eel utilization at all life stages through mandatory reporting of harvest and effort by commercial fishers and dealers, and enhanced recreational fisheries monitoring.
2. Increase understanding of factors affecting eel population dynamics and life history through increased research and monitoring.
3. Protect and enhance American eel abundance in all watersheds where eel now occur.
4. Where practical, restore American eel to those waters where they had historical abundance but may now be absent by providing access to inland waters for glass eel, elvers, and yellow eel and adequate escapement to the ocean for pre-spawning adult eel.
5. Investigate the abundance level of eel at the various life stages, necessary to provide adequate forage for natural predators and support ecosystem health and food chain structure.

The FMP requires all states and jurisdictions to implement an annual young-of-year (YOY) abundance survey to monitor annual recruitment of each year's cohort. In addition, the FMP requires a minimum recreational size, a possession limit and a state license for recreational fishermen to sell eels. The FMP requires that states and jurisdictions maintain existing or more conservative American eel commercial fishery regulations for all life stages, including minimum size limits. Each state is responsible for implementing management measures within its jurisdiction to ensure the sustainability of its American eel population.

The FMP has been adapted through the following addenda:

[Addendum I \(February 2006\)](#)

Addendum I establishes a mandatory catch and effort monitoring program for American eel.

[Addendum II \(October 2008\)](#)

Addendum II placed increased emphasis on improving the upstream and downstream passage of American eel with the goal of increasing escapement of silver eels to spawning grounds. The Board chose to delay action on management measures in order to incorporate the results of the 2012 stock assessment.

[Addendum III \(August 2013\)](#)

Addendum III was initiated in response to the findings of the 2012 Benchmark Stock Assessment, which declared American eel stock along the US East Coast depleted. Addendum III aimed to reduce mortality on all life stages of American eel. It required states to reduce the yellow eel recreational possession limit to 25 eel/person/day, with the option to allow an exception of 50 eel/person/day for party/charter employees for bait purposes. The recreational and commercial size limit increased to a minimum of 9 inches. Eel pots are required to be ½ by ½ inch minimum mesh size. The glass eel fishery is required to implement a maximum tolerance of 25 pigmented eels per pound of glass eel catch. The silver eel fishery is prohibited to take eels from September 1st to December 31st from any gear type other than baited traps/pots or spears. The Addendum also set minimum monitoring standards for states and required dealer and harvester reporting in the commercial fishery.

[Addendum IV \(October 2014\)](#)

Addendum IV was also initiated in response to the 2012 American Eel Benchmark Stock Assessment and the need to reduce mortality on all life stages. The Addendum established a coastwide cap of 907,671 pounds of yellow eel, reduced Maine's glass eel quota to 9,688 pounds (2014 landings), and allowed for the continuation of New York's silver eel weir fishery in the Delaware River. For yellow eel fisheries, the coastwide cap was implemented for the 2015 fishing year and established two management triggers: (1) if the cap is exceeded by more than 10% in a given year, or (2) the cap is exceeded for two consecutive years regardless of the percent overage. If either one of the triggers are met, then states would implement state-specific allocation based on average landings from 2011-2013. The addendum also requires any state or jurisdiction with a commercial glass eel fishery to implement a fishery independent life cycle survey covering glass, yellow, and silver eels within at least one river system.

### [Addendum V \(August 2018\)](#)

Addendum V increases the yellow eel coastwide cap starting in 2019 to 916,473 pounds to reflect a correction in the historical harvest data. Further, the Addendum adjusts the method (management trigger) to reduce total landings to the coastwide cap when the cap has been exceeded, and removes the implementation of state-by-state allocations if the management trigger is met. Management action will now be initiated if the yellow eel coastwide cap is exceeded by 10% in two consecutive years. If the management trigger is exceeded, only those states accounting for more than 1% of the total yellow eel landings will be responsible for adjusting their measures. A workgroup was formed to define the process to equitably reduce landings among the affected states when the management trigger has been met (see appendix, approved October 2019). Additionally, the Addendum maintains Maine's glass eel quota of 9,688 pounds. The Board also slightly modified the glass eel aquaculture provisions, maintaining the 200-pound limit for glass eel harvest, but adjusting the criteria for evaluating the proposed harvest area's contribution to the overall population consistent with the recommendations of the Technical Committee.

### [Addendum VI \(May 2024\)](#)

Addendum VI maintains Maine's glass eel quota of 9,688 pounds originally established under Addendum IV, to remain in place for 3 years (2025-2027) and be reviewed prior to the 2028 fishing year.

### [Addendum VII \(May 2024\)](#)

Addendum VII responds to the 2023 stock assessment findings that the American eel stock is depleted and the yellow eel population has continued to decline. Addendum VII set the coastwide yellow eel harvest cap to 518,281 pounds using an index-based method that provides management advice based on abundance indices and catch information, as well as management goals specified by the Board. The cap can be updated after three years with additional years of data. Addendum VII also removes the requirement for collecting individual lengths and pigment stage during the annual YOY surveys, and changes the *de minimis* policy to use a three-year average of landings to evaluate *de minimis* status.

## **II. Status of the Stock**

The first benchmark stock assessment for American eel was peer reviewed in March 2012 and was approved for management use in May 2012 (ASMFC 2012). Due to biological data limitations and the extremely complex life history of American eel, traditional stock assessment models could not be developed and several data-poor methods were used to assess the American eel resource. The stock status was determined to be depleted, and overfishing and overfished status could not be determined with confidence.

The 2017 American Eel Stock Assessment Update updated the 2012 American Eel Benchmark Stock Assessment with data from 2010-2016. The trend analysis results in this stock assessment update were consistent with the 2012 results, with few exceptions. Despite downward trends

in the indices, commercial yellow American eel landings were shown to be stable in the decades leading up to the assessment, but landings still remained much lower than historical levels. The conclusion of the assessment update was that the American eel population in the assessment range remains depleted (ASMFC 2017).

The most recent benchmark stock assessment was peer reviewed in late 2022 and accepted for management use in 2023. The 2023 assessment concludes that the stock is depleted at or near historically low levels due to a combination of historical overfishing, habitat loss, food web alterations, predation, turbine mortality, environmental changes, toxins and contaminants, and disease. Despite exploring additional approaches for assessing American eel that were suggested in past stock assessments including a delay-difference model, traffic light analysis and surplus production models, and developing an egg-per-recruit model, overfished and overfishing determinations still could not be made due to data limitations. However, the 2023 stock assessment found that the yellow eel population has declined since the previous assessment, and yellow eel harvest should be decreased.

### **III. Status of the Fishery**

Commercial fisheries for American eel occur throughout their range in North America, with the most significant of those fisheries occurring in the US Mid-Atlantic region and Canada. These fisheries are executed in riverine, estuarine, and ocean waters. In the US, commercial fisheries for glass eel/elvers only exist in Maine and South Carolina, a silver eel weir fishery exists in New York's Delaware River, and yellow eel fisheries exist in all states and jurisdictions except Pennsylvania and the District of Columbia.

Although eel have been continuously harvested over the last century, consistent data on harvest has not always been available. Harvest data from the Atlantic coastal states (Maine to Florida) indicate that the harvest fluctuated widely between 1970 and 1980, but showed an increasing trend that peaked in 1979 at 3,951,936 pounds. From then landings declined to a low of 641,000 pounds in 2002, recovered steadily to exceed one million pounds on average from 2010-2014, and have since experienced a general downward trend, reaching a time series low in 2020. Because fishing effort data are unavailable for the entire time series, finding a correlation between population numbers and landings data is difficult.

The Advisory Panel (AP) has provided feedback that recent low landings have primarily been related to market demand; demand for wild-caught American eels from the US for European food markets has decreased in recent years due to increased aquaculture in Europe. Demand for domestic bait decreased from 2019 to 2020 due in part to COVID-19 restrictions. A smaller proportion of landings traditionally goes to the domestic bait market, and the AP indicated that it does not anticipate landings to increase significantly from current levels in the near future.

#### ***Commercial Fishery***

State reported commercial landings of yellow/silver eels in 2023 totaled approximately 295,934

Pounds (Table 1, Figure 1), which represents a 10% decrease in landings from 2022 (327,206 pounds). Yellow eel landings increased in five states and jurisdictions, while decreasing in six. In 2023, state reported landings from Maryland, Virginia, and New Jersey together accounted for 80% of the coastwide commercial total landings. Glass eel landings reported from Maine totaled 9,510 pounds; South Carolina’s glass eel landings are confidential.

**Table 1. Preliminary 2023 Commercial Landings (in pounds) by State and Life Stage**

State/Jurisdiction	Glass	Yellow
Maine	9,510	3,522
New Hampshire	No Fishery	0
Massachusetts	No Fishery	<i>Confidential</i>
Rhode Island	No Fishery	2,559
Connecticut	No Fishery	2,899
New York	No Fishery	14,331
New Jersey	No Fishery	48,681
Pennsylvania	No Fishery	0
Delaware	No Fishery	11,090
Maryland	No Fishery	137,684
D.C.	No Fishery	0
PRFC	No Fishery	20,229
Virginia	No Fishery	50,970
North Carolina	No Fishery	1,109
South Carolina	Confidential (<750 pounds)	0
Georgia	No Fishery	0
Florida	No Fishery	2,860
<b>Total</b>	<b>Glass: Approx 9,510 Elver: 0</b>	<b>295,934</b>

Maine’s glass eel aquaculture proposal for the 2023 season was approved and 200 pounds were harvested for aquaculture grow out. Maine submitted a similar proposal for the 2024 fishing season that was also approved. For both years, the approved proposals allow for 200 pounds of glass eels to be harvested for aquaculture in addition to Maine’s glass eel quota of 9,688 pounds.

**Table 2. State commercial regulations for the 2023 fishing year.\***

State	Min Size	License/Permit	Other
ME	Glass: No minimum size	Daily dealer reports/swipe card program; monthly harvester report of daily landings. Tribal permit system in place for some Native American groups.	In 2017, the Legislature authorized the DMR commissioner to adopt rules to implement the elver fishing license lottery, including provisions for the method and administration of the lottery.

State	Min Size	License/Permit	Other
	Yellow: 9"	Harvester/dealer license and monthly reporting. Tribal permit system in place for some Native American groups.	Seasonal closures. Gear restrictions. Weekly closures. Mesh size restrictions on eel pots.
NH	9"	Commercial saltwater license and wholesaler license and harvest permit. No dealer reports. Monthly harvester reporting includes dealer information.	Gear restrictions in freshwater. Mesh size restrictions on eel pots.
MA	9"	Commercial permit with annual catch report requirement. Registration for dealers with purchase record requirement. Dealer/harvester reporting.	Traps, pots, spears, and angling only. Mesh size restrictions on eel pots.
RI	9"	Commercial fishing license. Dealer/harvester reporting.	Seasonal gear restrictions. Mesh size restrictions on eel pots.
CT	9"	Commercial license (not required for personal use). Dealer/harvester reporting.	Gear restrictions. Mesh size restrictions on eel pots.
NY	9"	Harvester/dealer license and monthly reporting.	Gear restrictions. Maximum limit of 14" in some rivers. Mesh size restrictions on eel pots.
NJ	9"	License required. No dealer reports. Monthly harvester reporting includes dealer information.	Gear restrictions. Mesh size restrictions on eel pots.
PA	NO COMMERCIAL FISHERY		
DE	9"	Harvester reporting, no dealer reporting. License required.	Commercial fishing in tidal waters only. Gear restrictions. Mesh size restrictions on eel pots.
MD	9"	Dealer/harvester license and monthly reporting. Limited entry.	Prohibited in non-tidal waters. Gear restrictions. Commercial crabbers may fish 50 pots per day, must submit catch reports. Mesh size restrictions on eel pots.
DC	NO COMMERCIAL FISHERY		
PRFC	9"	Harvester license and reporting. No dealer reporting.	Seasonal gear restrictions. Mesh size restrictions on eel pots.
VA	9"	Harvester license/eel buyer permit required. Dealer/harvester monthly reporting.	Mesh size restrictions on eel pots. Seasonal closures.
NC	9"	Standard Commercial Fishing License for all commercial fishing. Dealer/harvester monthly combined reports on trip ticket.	Mesh size restrictions on eel pots. Seasonal closures. No commercial harvest in inland waters.
SC	Glass No minimum size	Dealer/harvester monthly combined reports on trip ticket. License and gear permits required.	Max 10 individuals. Gear and area restrictions. Fyke and dip net only

State	Min Size	License/Permit	Other
			permitted. Mesh size restrictions on eel pots.
	Yellow 9"	Dealer/harvester monthly combined reports on trip ticket. License and gear permits required.	Pots and traps permitted only. Gear restrictions. Mesh size restrictions on eel pots.
GA	9"	Personal commercial fishing license and commercial fishing boat license. Dealer/harvester monthly combined reports on trip ticket.	Gear restrictions on traps and pots. Area restrictions. Mesh size restrictions on eel pots.
FL	9"	Permits and licenses. Harvester reporting. No dealer reporting.	Gear restrictions. Mesh size restrictions on eel pots.

\* For specifics on licenses, gear restrictions, and area restrictions, please contact the individual state.

### ***Recreational Fishery***

Available information indicates that few recreational anglers directly target American eel. For the most part, hook-and-line fishermen catch eel incidentally when fishing for other species. American eel are often purchased by recreational fishermen for use as bait for larger gamefish such as striped bass, cobia, and catfish. Some recreational fishermen may catch their own to use as bait.

Despite the incidental nature of hook-and-line eel catches, the National Marine Fisheries Service (NMFS) Marine Recreational Information Program (MRIP) does encounter enough observations to indicate widespread and common presence as a bycatch species. However, there is low precision associated with the recreational fishery statistics for American eel due to the limited numbers that have been encountered during surveys of recreational anglers along the Atlantic coast. These limited numbers are partly due to the design of the MRIP survey, which does not sample from the areas and gears assumed to be responsible for the majority of recreational fishing for American eels. As such, the recreational fishery statistics for American eels provided by MRIP should be interpreted with caution.

MRIP shows a declining trend in the coastwide recreational eel catch starting in the 1980s, but the total annual harvest values are highly uncertain. As of 2009, MRIP no longer provides recreational data for American eel due to the survey design being unsuitable for sampling targeted eel fishing. At the state level, only New Hampshire and Georgia collect recreational data for American eel outside of MRIP.

**Table 3. State recreational regulations for the 2023 fishing year.\***

State	Min Size	Daily Possession Limit	Other
-------	----------	------------------------	-------

ME	9"	25	Gear restrictions. License requirement and seasonal closures (inland waters only). Bait limit of 50 eels/day for party/charter boat captain and crew.
NH	9"	25	Coastal harvest permit needed if taking eels other than by angling. Gear restrictions in freshwater.
MA	9"	25	Nets, pots, traps, spears, and angling only; seasonal gear restrictions and mesh requirements. Bait limit of 50 eels/day for party/charter boat captain and crew.
RI	9"	25	Bait limit of 50 eels/day for party/charter boat captain and crew.
CT	9"	25	
NY	9"	25	Maximum limit of 14" in some rivers. Bait limit of 50 eels/day for party/charter boat captain and crew.
NJ	9"	25	Bait limit of 50 eels/day for party/charter boat captain and crew. Mesh size restriction on pots.
PA	9"	25	Gear restrictions.
DE	9"	25	Two pot limit/person.
MD	9"	25	Gear restrictions.
DC	9"	10	
PRFC	9"	25	
VA	9"	25	Recreational license. Two pot limit. Mandatory monthly catch report. Gear restrictions. Bait limit of 50 eels/day for party/charter boat captain and crew.
NC	9"	25	Gear restrictions. Non-commercial special device license. Two eel pots allowed under Recreational Commercial Gear license. Bait limit of 50 eels/day for party/charter boat captain and crew.
SC	9"	25	Gear restrictions. Permits and licenses. Two-pot limit.
GA	9"	25	
FL	9"	25	Gear restrictions. Wholesale/retail purchase exemption applies to possession limit for bait.

\* For specifics on licenses, gear restrictions, and area restrictions, please contact the individual state.

#### IV. Status of Research and Monitoring

The FMP requires states and jurisdictions with a declared interest in the species to conduct an annual YOY survey to monitor annual recruitment of each year's cohort. Some states conduct yellow eel surveys as well.

In 2023, the states and jurisdictions of Maine, New Hampshire, Massachusetts (Wankinco River), Connecticut (Lamprey River), New York, New Jersey, the Potomac River Fisheries Commission, and South Carolina all observed relatively high YOY counts. The catch in Maine was the third largest in the time series, and the yellow eel catch was the largest in the time series. The Lamprey River catch and CPUE of YOY eel in New Hampshire were also the second largest in the time series. The Connecticut YOY CPUE for 2023 was lower than last year and the



third-highest value in the time series. In the New York glass eel survey the geometric mean catch of glass eels in 2023 was the highest catch rate in the time series. The New Jersey YOY CPUE was higher than the time series average but lower than the last two years. The PRFC relative abundance index for glass eels was the highest ever observed at Gardy's Millpond in 2023, exceeding the previous record set in 2022, and the elver index was also well above average.

All other YOY surveys in 2023 (Massachusetts, Rhode Island, Pennsylvania, Delaware Maryland, North Carolina, and Florida) had at or below average survey counts. The Massachusetts YOY index from the Jones River remains below average, but has been increasing for three years in a row. In Delaware the YOY catch was the seventh lowest annual geometric mean catch for the 24-year time series. In Maryland, the total number of glass eels captured and CPUE in 2023 ranked fifth lowest and third lowest over the full time series, respectively. Maryland's 2023 Sassafras River yellow eel pot survey CPUE was lower than last year, but the CPUE shows an overall increasing trend since 2006. In 2023, American eel relative abundance in the North Carolina YOY survey remained below the time-series average for the third year. The catch rates in the Goose Creek YOY survey in South Carolina decreased to time-series lows after an increase in 2022. Relative abundance of American Eel in the SCDNR Electrofishing Survey in 2023 was 5<sup>th</sup> lowest in time series, but increased from 2022. Catch at Florida's Guana River Dam remained at the lowest level in the time series.

Pennsylvania, D.C., and Georgia do not have YOY surveys, but instead have yellow eel surveys. Pennsylvania's 2023 survey catch was below average, and D.C. saw increased catch in their backpack electrofishing survey but very low catch in their boat-based electrofishing survey. New Jersey additionally developed and implemented a fishery-independent eel pot survey to collect abundance data of yellow American eels within nursery grounds. This survey, which began in 2015, supplements the current glass eel survey by sampling more life stages and will allow biologists to collect additional biological samples (age-length-weight data). The 2023 yellow eel CPUE in New Jersey was the highest in the time series.

As required by Addendum IV, Maine continued the fishery independent life cycle survey of glass, yellow, and silver eels within at least one river system (West Harbor Pond) in 2023. This site was changed from Cobboosecontee Stream to West Harbor Pond to improve collection of eels at all life stages by Maine Department of Marine Resources staff starting in 2019.

## **V. Research Needs**

The FMP does not require any other research initiatives for participating states and jurisdictions. Nonetheless, the American Eel Technical Committee (TC) has identified several research topics to further understanding of the species' life history, behavior, and biology. Research recommendations from ASMFC (2012, 2017) remain important, but the following list was provided in the 2023 benchmark stock assessment, and is specific to what the Stock

Assessment Subcommittee thinks could improve the next stock assessment. Research needs for American eel identified by the TC include:

### ***Future Research and Data Collection***

- Improve upstream and downstream passage for all life stages of American eels.
- Continue to improve the accuracy of commercial catch and effort data through ACCSP and state partners
- Characterize the length, weight, age, and sex structure of commercially harvested American eels along the Atlantic coast over time.
- Research coastwide prevalence of the swim bladder parasite *Anguillacolla crassus* and its effects on the American eel's growth and maturation, migration to the Sargasso Sea, and spawning potential.
- Improve understanding of the spawning contribution of unexploited portions of the stock (i.e., freshwater areas of coastal US).
- Characterize the length, weight, and sex structure in unharvestable habitats.
- Conduct a tagging study throughout the species range.
- Quantify recreational removals in marine and freshwater habitats and characterize length, weight, and sex structure.
- Evaluate the passage/passage efficiency of American eels through existing fishways at dams/barriers and evaluate barrier physical attributes (height, material) that can be passed by eel without fishways.
- Evaluate the use vs. availability of habitat in the inland portion of the species range, and how habitat availability has changed through time, including opening of habitat from recent dam and barrier removals. This could and should include assisted migration by trucking around dams.
- To the extent that the data allows, account for the proportion of the population (yellow, silver phase) represented by the inland portion of the species range.
- Evaluate the relative impact that commercial harvest has on population status versus the accessibility to inland habitats.

### ***Assessment Methods***

- Develop methods to assess spawner escapement and biological information pertinent to silver eels in major river basins.
- Perform a range-wide American eel assessment with various countries and agencies (e.g., Canada DFO, ASMFC, USFWS, Caribbean, US Gulf and inland states).
- Explore methods to characterize data by sex to support a female-only delay-difference model.

## **VI. Status of Management Measures**

The FMP requires that all states and jurisdictions implement an annual YOY abundance survey in order to monitor annual recruitment of each year's cohort. Addendum III requires a 9-inch

minimum size restriction in the commercial and recreational yellow eel fisheries, as well as a minimum mesh size of ½ by ½ inch in the commercial yellow eel pot fishery. The recreational bag limit is 25 fish/angler/day, and the silver eel fishery is restricted, as is the development of pigmented eel fisheries.

## **VII. Current State-by-State Implementation of FMP Compliance Requirements**

The PRT reviewed the state compliance reports for the 2023 fishing year. The PRT notes the following issues with state implementation of the required provisions of the American Eel FMP:

### Yellow Eel Measures

- New York’s regulations for minimum mesh size do not meet the requirements of the FMP. Addendum III requires states and jurisdictions to implement a ½ by ½ inch minimum on the mesh size used in commercial yellow eel pots. New York’s regulation is as follows: “Minimum mesh size must be one inch by one-half inch, unless such pots contain an escape panel that is at least four inches square with a mesh size of one inch by one-half inch located so that the panel is on a side, but not at the bottom of a pot.” Addendum III allowed states to use a 4 by 4 inch escape panel constructed of a mesh size of at least ½ by ½ inch mesh in order to reduce the financial burden of gear changes on the fishery for three years (until January 1, 2017). Because this provision has expired, New York should require the minimum mesh size for all yellow eel pots, regardless of the presence of an escape panel.
  - New York Regulations are currently being updated to remove the escape panel exemption and change the minimum mesh size requirements to 1/2” by 1/2”. The regulations should be adopted in late 2024.

### Silver Eel Fishery Measures:

- Delaware has not implemented regulations preventing harvest of eels from pound nets from September 1 through December 31. No pound net landings have been reported in the state in over 50 years. Delaware will address this issue as part of any future changes to the eel regulations.
- Florida does not have a regulation preventing harvest of eels from pound nets from September 1 through December 31, but the state is unaware of any active pound net fishery in the past 10-15 years.

### Reporting Measures:

- The following jurisdictions do not have dealer reporting:
  - New Hampshire and New Jersey do not have dealer reporting (there are no permitted eel dealers for either state), but harvesters report some information on dealers.
  - Delaware (no permitted eel dealers)
  - Potomac River Fisheries Commission (jurisdiction reports harvest, not landings)

- Florida (considered a freshwater species and there is dealer reporting for freshwater species)
- Many states have been unable to provide information on the percent of commercial harvest sold as food versus bait; only Maine, New York, New Jersey, Delaware, and Florida provided this information for 2023.

Addendum VII to the American Eel FMP stipulates that a state may apply for *de minimis* status for each life stage if (given the availability of data), for the preceding three years, its average commercial landings (by weight) of that life stage constitute less than 1% of the coastwide commercial landings for that life stage for the same three-year period. States meeting this criterion are exempted from having to adopt commercial and recreational fishery regulations for a particular life stage listed in the FMP under Section 4 and any fishery-dependent monitoring elements for that life stage listed in Section 3.4.1.

Qualification for *de minimis* is determined from state-reported landings found in annual compliance reports. New Hampshire, Massachusetts, Pennsylvania, District of Columbia, Georgia, and Florida have requested continued *de minimis* status for their yellow eel fisheries. Florida does not qualify as the average state landings for 2021-2023 exceed 1% of the average coastwide yellow eel landings for 2021-2023. All other states that applied for *de minimis* of the yellow eel fishery meet the *de minimis* criteria.

### **VIII. Recommendations/Findings of the Plan Review Team**

1. The PRT recommends the Board consider state compliance notes as detailed in Section VII.
2. The PRT recommends *de minimis* be granted to Massachusetts, New Hampshire, Pennsylvania, District of Columbia, and Georgia for their yellow eel fisheries.
3. The PRT had previously requested that the Board reevaluate the requirement that states provide estimates of the percent of harvest going to food versus bait, as there is a high level of uncertainty and subjectivity inherent in the data. Additionally, the PRT notes that this information does currently impact regulations and is unclear of the benefit for management.
4. The PRT requests again that the Board consider tasking the Committee on Economic and Social Sciences to conduct an analysis of the market demand for all life stages of eel, specific to food vs bait markets, as well as international market demand.
5. The PRT recommends that the Commission and USFWS work together to annually compare domestic landings data to export data for American eel across all life stages.

### **IX. References**

Atlantic States Marine Fisheries Commission (ASMFC). 1998. Interstate Fishery Management Plan for American Eel (*Anguilla rostrata*). Washington D.C. NOAA Oceanic and Atmospheric

Administration Award No. NA97 FGO 0034 and NA07 FGO 024.

Atlantic States Marine Fisheries Commission (ASMFC). 2023. American Eel Benchmark Stock Assessment. Arlington, VA.